



TODAY'S COOKING SOLUTIONS



**2026**  
PRICE LIST



**Southbend combines over a century of expertise with cutting-edge technology to deliver reliable, high-performance solutions for professional kitchens.**

# JANUARY 2025 EDITION

**FOR AUTHORIZED DEALERS -TERMS** are net 30, with approved credit. Products are shipped FOB Fuquay-Varina, North Carolina. All steam equipment - (for shipment outside the continental United States), is shipped FOB Toronto, Canada. Prices are subject to change without notice.

**RETURNS\*:** **Prior authorization** must be received in order to return merchandise. Credit will be issued for returned product less initial delivery freight cost. All authorized returns must be freight prepaid, and are subject to a 35% restocking charge. All authorized returns will be paid by credit memo. Refurbishing, if necessary, will be an additional charge and will be deducted from any credit that may be allowed. Items not stocked, specially configured or built to order do not qualify for return. Any specials that are authorized for return, may be subject for a fee beyond the standard restocking fee. Returns must be received at the assigned return address within sixty (60) days from authorization date. Southbend reserves the right to refuse or charge a 45% restocking fee on equipment returned without prior authorization.

\*Custom options are non-refundable, non returnable items.

**TITLE** passes to the consignee when merchandise is accepted by the carrier, and thereafter travels at the risk of the purchaser. FOB Factory.

**SUBSTITUTIONS** in material or design will be made as needed, and may be done without notification when necessary. PLEASE SPECIFY (a) finish, (b) type of gas, (c) BTU content, (d) altitude (where applicable), or (e) voltage, (f) phase and (g) cycle when ordering.

**BATTERIES:** To insure proper alignment and fillers, list battery alignment from **"left to right"** as you face the equipment lineup.

**CHANGES:** Additional costs incurred due to changes requested within two weeks of scheduled shipping date will be chargeable.

**PRICES** in this list are **limited to goods purchased and shipped in the United States**. Please apply to the factory or one of its export agents for quotations on merchandise to be shipped into other areas. All prices are in U.S. dollars. All prices are subject to change without prior notice.

**PERFORMANCE CHECK:** This is only done after the start up has been performed by the installer. This check includes a 15 point examination by the service agent to be sure the equipment has been installed and started up correctly. Available for all Southbend equipment, except S-Series ranges and Fryer Filtration Systems, within 50 miles of the nearest service agent.

**To learn more about Southbend and our wide array of Commercial Kitchen Equipment, or for a complete listing of Sales Representative and Service Agencies, visit us at [www.southbendnc.com](http://www.southbendnc.com)**

To speak with a Customer Service Representative contact us at **919-762-1000 option 1**  
When placing an order **email [sbpo@southbendnc.com](mailto:sbpo@southbendnc.com)**. For more information on Southbend and our array of Commercial Kitchen Equipment, visit us at [www.southbendnc.com](http://www.southbendnc.com).

*All of our products are listed by UL, CSA and NSF (where applicable)*

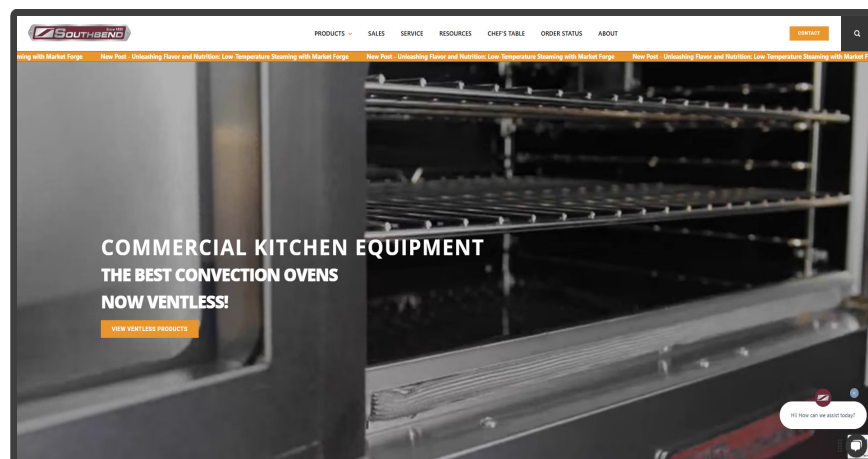

# TABLE OF CONTENTS



## HEAVY DUTY EQUIPMENT

**Platinum Heavy Duty Sectional..... 8-27**

## BROILERS



**Upright Electric Broilers ..... 30**

**24" Electric Broiler..... 31**

**Upright Gas Radiant Broilers - Sectional Match ..... 32**

**Upright Gas Infrared Broilers - Sectional Match ..... 33**

**Upright Gas Broilers - Infrared & Radiant..... 34**

**Steakhouse Broiler..... 35**

**Salamander and Cheesemelters..... 36-37**

## RESTAURANT RANGES



**Heavy Duty Electric Ranges ..... 39**

**The Ultimate Ranges..... 40-51**

**S-Series Ranges ..... 52-53**



## FRYERS

**Fryers ..... 55**

**Pasta Cooker and Rinse Station ..... 56**

## HEAVY DUTY COUNTERLINE



**High Volume Griddle ..... 58**

**Heavy Duty Counterline..... 59-61**

**Catering/Outdoor..... 62-63**

## CONVECTION OVENS



**TruVection - Low Profile Convection Oven ..... 67**

**Convection Ovens ..... 70-75**

**Half Size ..... 76-77**

**Platinum PRO Series ..... 80-85**

# TABLE OF CONTENTS



Counter Steamers.....	89-93
Counter Pressure Steamers.....	94
Twin Generator Convection Steamers .....	96-97
Heavy Duty Steamers.....	99-101
Pressure Cookers.....	103-104
Kettles and Boiler Base.....	105-107
Counter Kettles .....	109-112
Floor Kettles.....	113-130
Braising Pans and Tilting Skillets .....	131-136



## TERMS AND RESOURCES

Prison Options .....	137-139
Southbend Warranty .....	140-141
Southbend Extended Warranty .....	142-143
Southbend Map Policy.....	144-145

To speak with a Customer Service Representative contact us at **919-762-1000 option 1**. When placing an order, please **email sbpo@southbendnc.com**. For more information on Southbend and our array of Commercial Kitchen Equipment, visit us at [www.southbendnc.com](http://www.southbendnc.com).

*All of our products are listed by UL, CSA and NSF (where applicable)*

# Freight Information

---



Third Party Billing for Hawaii and Alaska

---



Freight Rates for orders under \$20,000

---

\$0 - \$19,999.99 - 3% of total order

FREIGHT DAMAGE: **DO NOT SIGN** for equipment until you have thoroughly inspected it for obvious or concealed freight damage. Once signed for, the customer takes full responsibility for the shipment. We can, however, assist the customer if a freight claim is needed.

**Notes: Rates ONLY apply if:**

1. Freight ships from Southbend warehouse location.
2. Southbend chooses freight carrier.

**Additional Charges**

Lift Gate Delivery = \$150.00  
All other requests, call for pricing.

**Freight Classification**

The bulk of Southbend commercial equipment is rated 92.5.

Special configurations or non-standard crating may add to the classification.

Rate classifications are subject to change without notice.



# Platinum Series

## Heavy Duty Sectional

Engineered for the rigors of high volume kitchens with virtually unlimited designs to withstand the weight of large stock pots and the abuses seen in modern kitchens. With thousands of configurations to choose from, Southbend can help you deliver your promise to your customers.

### STANDARD PLATINUM SERIES FEATURES:

- 100% Stainless Steel Construction
- WATER RESISTANT Welded Control Panels and Construction
- Ranges can be mounted on Counter, Cabinet, Standard Oven, Convection Oven, TruVection, Refrigerated or Freezer Bases
- FRONT and REAR Gas Connections
- Unique Dual Radiant Low Profile Charbroiler
- PATENTED Heat Bank Griddle Design
- Stainless Steel Cabinet with Removable Doors
- 5" Flue Riser
- Heavy-Duty Solid Stainless Steel Removable Shelf Standard with Shelf Risers
- Porcelain Oven Interior with Optional Stainless Steel Interior
- PATENTED On/Off Convection Oven Fan Controls
- 550°F oven with standing pilot on ALL Standard and Convection Oven Bases. Electronic ignition available in lieu of standing pilot at no charge.
- PATENTED 35,000 BTU Non-clogging Burners with Lifetime Warranty
- PATENTED 45,000 BTU Signature Pyromax Non-clogging Burners with Lifetime Warranty
- Removable Welded Steel Grates with Optional Cast Iron Grates Available
- One year Warranty on Operational Parts and one year Warranty on Labor
- One Year Warranty on Operational Parts and One Year Warranty on Labor for Island Suites and Waldorf Suites.



# CREATING TODAY'S COOKING SOLUTIONS

Platinum Series Sectional offers virtually an unlimited number of designs and configuration to fit any kitchen's need. Offering thousands of possible combinations, as well as options and accessories, personalizing your kitchen is up to you. You can choose from open top burners to griddles, charbroilers, planchas, and hot tops, in a variety of sizes and combinations. Building the perfect complement is limitless. With a vast array of models to choose from, Southbend has created a model naming system to simplify the selections in designing your optimal kitchen equipment layout.

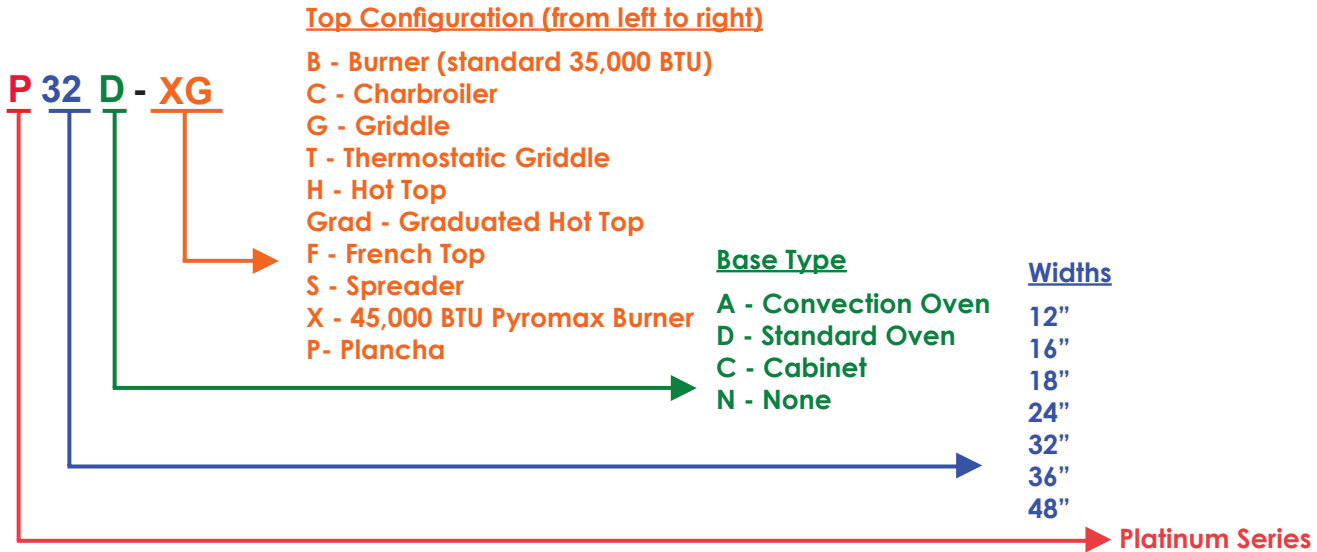

## Competitive Information

Standard Features:	Southbend Platinum	Garland Master	Montague Legend	Vulcan V Series
All stainless	Yes	No	No	No
Sectional footprint	32" or 36"	34"	36"	36"
Fully welded frame	No	No	Yes	Yes
Rear gas connection standard	Yes	No	No	Yes
Rear gas size	1"	3/4", 1", 1-1/4"	3/4", 1-1/4"	1-1/4"
Front manifold size	1-1/4"	1-1/4"	1-1/4"	1-1/4"
Standard open top BTU (NAT)	35K	24K	30K	35K
Optional open top BTU (NAT)	45K	30K	30K	n/a
Lifetime non-clog burner	Yes	No	No	No
One piece burner	Yes	No	No	No
Removable welded steel grates	Yes	No	No	No
Fabrication done in-house	Yes	No	Yes	No
Stainless sides and back standard	Yes	No	No	Yes
Warranty	1 year	2 year	1 year	1 year
Battery spark ignition (Closed Tops)	Yes	Yes	No	No
Full porcelain oven interior	Yes	Yes	Yes	No
Oven rack positions	5	4	3	3
Racks included	3	1	1	1
Oven BTUs Std/Convection	45K	40K	40K	50K/32K
Oven temperature range	150°F-550°F	150°F-500°F	low-500°F	150°F-550°F
Continuous front rail on every piece	Yes	No	No	No
Refrigerated base mount	Yes	No	Yes	Yes



# STAINLESS CONSTRUCTION

## THE ONLY U.S. MADE COOKING LINE CONSTRUCTED OF 100% STAINLESS STEEL

(EXCLUDES CASTINGS, FORGINGS, AND NON-STRUCTURAL COMPONENTS)

### Platinum Heavy Duty Series

- 1 year limited parts and labor warranty
- Industry Leading 24/7 Warranty Service -

### Ideal for line-ups

- Island suites, custom layouts
- and any high volume location -

### Endless list of options

- Planchas, Refrigerated bases,
- TruVection and many more! -

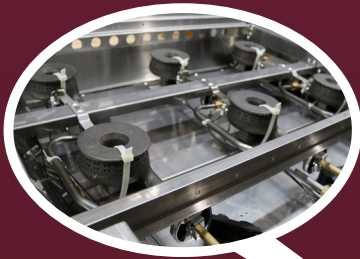

- Extra Heavy Duty Fully Welded Top Grates
- Non Clog 35,000 BTU top burners with Lifetime warranty
- Optional 45,000 BTU Pyromax Burner available
- Rear Gas Manifold -No Charge

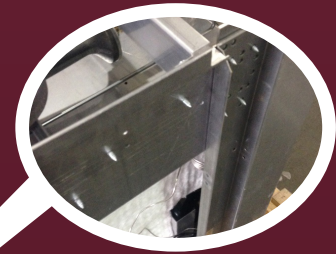

- All Stainless Steel Including:
- Interior Frame, Burner Box, Back and Bottom
  - Interior/Exterior 430+304 Stainless Steel
  - Available in 32" and 36" footprint



- Full Porcelain Oven Interior
- 2 Oven Racks
- Sheet Pan Fits Both Ways
- 45,000 BTU Oven Burners
- Optional TruVection Oven ~ Available for True-Baking~



- Modular Top Construction
- Extra Heavy Duty Door Handle
- Heavy Duty Metal knobs with thermal break
- Easy to clean One Piece Grease tray

\*\*Please see the Southbend Limited Warranty Page for full warranty coverage details.



# SALES ENGINEERING AND CUSTOM DESIGNS

Platinum is a premier cooking line that can be designed to meet the needs of any kitchen. To help our customers receive their ideal cooking system, Southbend's Sales Engineering and Customs Department will assist every step of the way. To ensure a successful delivery of the Platinum Cooking System, Southbend offers the Battery Assistance Program at NO CHARGE.

## BATTERY ASSISTANCE PROGRAM - WHEN SPECIFIED, SOUTHBEND WILL:

- Provide you with a Plan, Elevation and Isometric drawings of the battery.
- Assemble the battery at our facility per approved engineering drawings.
- Label the sections with color-coded tape before breaking down the battery. This will show where each piece was installed in the battery and will make for an easier and more timely installation.
- Take digital pictures of the battery and send to customer.
- Mark shipping crates on two sides with Item Number, Model, Battery Number, and Kitchen.
- Ship units in assembled sections or blocks for ease of installation. When possible; risers, shelves and/or compact broilers will be mounted.
- Project Manager specific to your order.
- OEM components and custom fabrication.
- Installation and follow-up support.

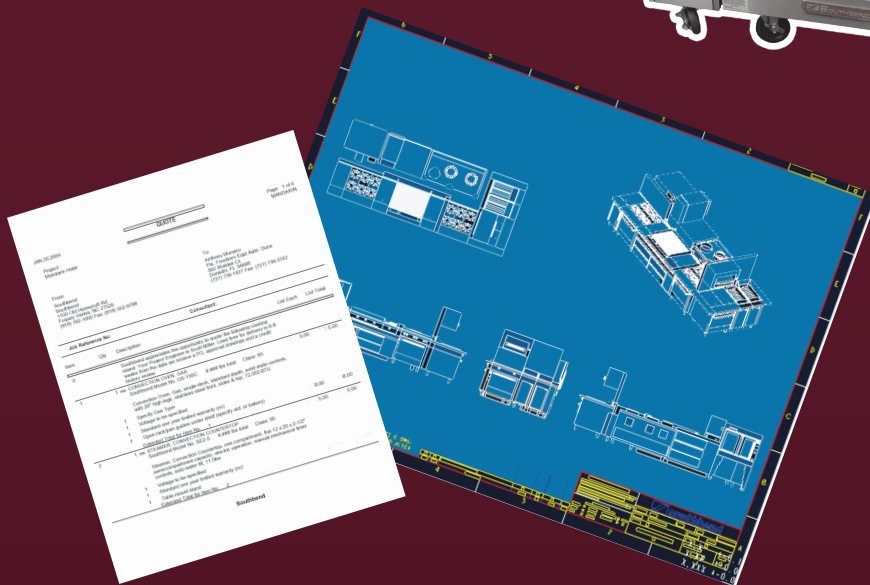

Quote includes Plan, Elevation and Isometric drawings of the battery.





P36D-BBB  
w/ optional flue riser and casters

# Open Top Range

- **PATENTED** 35,000 BTU non-clogging burners with lifetime warranty
- **PATENTED** 45,000 BTU Signature Pyromax™ non-clogging burners
- Removable welded grates, optional cast iron grates
- Stainless steel construction standard
- 35,000 BTU burners also available in step-up configurations



P36D-BBB-SU  
w/ optional flue riser and casters

## Open Top - 35,000 BTU

Configuration		Oven Base	Model Number	Weight	Dimension WxHxD
12" open top with 2 -35,000 BTU burners		none cabinet	P12N-B/ P12N-B-SU P12C-B/P12C-B-SU	130 (59) 200 (91)	12"x13.5"x37.5" 12"x41"x37.5"
24" open top with 4 -35,000 BTU burners		none cabinet	P24N-BB/P24N-BB-SU P24C-BB/P24C-BB-SU	260 (118) 400 (181)	24"x13.5"x37.5" 24"x41"x37.5"
32" open top with 6 -35,000 BTU burners		none cabinet standard convection	P32N-BBB / P32N-BBB-SU P32C-BBB / P32C-BBB-SU P32D-BBB / P32D-BBB-SU P32A-BBB / P32A-BBB-SU	260 (118) 450 (204) 530 (240) 670 (304)	32"x13.5"x37.5" 32"x41"x37.5" 32"x41"x37.5" 32"x41"x40.25"
36" open top with 6 -35,000 BTU burners		none cabinet standard convection	P36N-BBB / P36N-BBB-SU P36C-BBB / P36C-BBB-SU P36D-BBB / P36D-BBB-SU P36A-BBB / P36A-BBB-SU	390 (178) 600 (272) 706 (320) 759 (344)	36"x13.5"x37.5" 36"x41"x37.5" 36"x41"x37.5" 36"x41"x40.25"
48" open top with 8 -35,000 BTU burners		none cabinet standard convection	P48N-BBBB / P48N-BBBB-SU P48C-BBBB / P48C-BBBB-SU P48D-BBBB / P48D-BBBB-SU P48A-BBBB / P48A-BBBB-SU	276 (125) 462 (209) 568 (257) 621 (281)	48"x13.5"x37.5" 48"x41"x37.5" 48"x41"x37.5" 48"x41"x40.25"

## Pyromax™ Open Top - 45,000 BTU

Configuration		Oven Base	Model Number	Weight	Dimension WxHxD
16" open top with 2 -45,000 BTU burners		none cabinet	P16N-X P16C-X	150 (68) 220 (100)	16"x13.5"x37.5" 16"x41"x37.5"
18" open top with 2 -45,000 BTU burners		none cabinet	P18N-X P18C-X	150 (68) 220 (100)	18"x13.5"x37.5" 18"x41"x37.5"
32" open top with 4 -45,000 BTU burners		none cabinet standard convection	P32N-XX P32C-XX P32D-XX P32A-XX	315 (143) 490 (223) 630 (286) 670 (305)	32"x13.5"x37.5" 32"x41"x37.5" 32"x41"x37.5" 32"x41"x40.25"
36" open top with 4 -45,000 BTU burners		none cabinet standard convection	P36N-XX P36C-XX P36D-XX P36A-XX	315 (143) 490 (222) 630 (286) 670 (305)	36"x13.5"x37.5" 36"x41"x37.5" 36"x41"x37.5" 36"x41"x40.25"

Note: In the model number: "D" specifies standard oven and "A" specifies convection oven. Number of racks: standard oven has 2 racks and convection oven has 3 racks. Standard and convection ovens are located on left side of 48" range with 12" cabinet on right.

# Charbroiler



The Platinum Charbroiler with triple radiant heating surface design, provides a powerful, even heating surface.

- 40,000 BTU burners every 16" (16" and 32" units)
- 32,000 BTU burners every 12" (12", 24", 36" and 48" units)
- Briquette or Radiant - field convertible
- Stainless steel burners with Hi/Lo setting
- Removable cast iron grates with double sided grids
- Stainless steel construction standard
- Models shown with optional casters

P36D-CCC  
w/ optional casters & flue riser

## Charbroilers

\* Salamanders can not be mounted over charbroilers

Configuration		Oven Base	Model Number	Weight	Dimension WxHxD
12" charbroiler with 32,000 BTU		none cabinet	P12N-C P12C-C	175 (86) 225 (102)	12"x13.5"x37.5" 12"x41"x37.5"
16" charbroiler with 40,000 BTU		none cabinet	P16N-C P16C-C	240 (108) 270 (122)	16"x13.5"x37.5" 16"x41"x37.5"
18" charbroiler with 48,000 BTU		none cabinet	P18N-C P18C-C	270 (122) 300 (136)	18"x13.5"x37.5" 18"x41"x37.5"
24" charbroiler with 64,000 BTU		none cabinet	P24N-CC P24C-CC	260 (118) 400 (181)	24"x13.5"x37.5" 24"x41"x37.5"
32" charbroiler with 80,000 BTU		none cabinet standard convection	P32N-CC P32C-CC P32D-CC P32A-CC	400 (182) 560 (255) 700 (318) 740 (336)	32"x13.5"x37.5" 32"x41"x37.5" 32"x41"x37.5" 32"x41"x40.25"
36" charbroiler with 96,000 BTU		none cabinet standard convection	P36N-CCC P36C-CCC P36D-CCC P36A-CCC	400 (182) 560 (255) 700 (318) 740 (336)	36"x13.5"x37.5" 36"x41"x37.5" 36"x41"x37.5" 36"x41"x40.25"
48" charbroiler with 128,000 BTU		none cabinet standard convection	P48N-CCCC P48C-CCCC P48D-CCCC P48A-CCCC	500 (225) 660 (297) 800 (360) 840 (378)	48"x13.5"x37.5" 48"x41"x37.5" 48"x41"x37.5" 48"x41"x40.25"

Note: In the model number: "D" specifies standard oven and "A" specifies convection oven. "G" specifies manual griddle and "T" specifies thermostatic controls. Number of racks: standard oven has 2 racks and convection oven has 3 racks. Standard and Convection ovens are located on left side of 48" range with 12" cabinet on right.



# Griddle



P36D-TTT  
w/ optional casters & flue riser

Southbend Griddles feature "Insta-on" controls and **PATENTED "heat bank"** technology - giving you significantly faster and more evenly distributed heat than typical gas fired griddles.

- 40,000 BTU burners every 16"  
(16", 32", and 48" units)
- 32,000 BTU burners every 12"  
(12", 24", and 36" units)
- 1" thick polished griddle plate
- Manual or thermostatic controls
- Standard with battery spark ignition
- Stainless steel construction standard
- Models shown with optional casters

## Griddles - Standard with battery spark ignition

Configuration		Oven Base	Model Number	Weight	Dimension WxHxD
12" griddle with 32,000 BTU		none cabinet	P12N-G P12C-G	175 (86) 225 (102)	12"x13.5"x37.5" 12"x41"x37.5"
16" griddle with 40,000 BTU		none cabinet	P16N-G / P16N-T P16C-G / P16C-T	240 (108) 270 (122)	16"x13.5"x37.5" 16"x41"x37.5"
18" griddle with 40,000 BTU		none cabinet	P18N-T P18C-T	250 (113) 280 (127)	18"x13.5"x37.5" 18"x41"x37.5"
24" griddle with 64,000 BTU		none cabinet	P24N-GG / P24N-TT P24C-GG / P24C-TT	300 (136) 330 (150)	24"x13.5"x37.5" 24"x41"x37.5"
32" griddle with 80,000 BTU		none cabinet standard convection	P32N-GG / P32N-TT P32C-GG / P32C-TT P32D-GG / P32D-TT P32A-GG / P32A-TT	400 (182) 560 (255) 700 (318) 740 (336)	32"x13.5"x37.5" 32"x41"x37.5" 32"x41"x37.5" 32"x41"x40.25"
36" griddle with 96,000 BTU		none cabinet standard convection	P36N-GGG / P36N-TTT P36C-GGG / P36C-TTT P36D-GGG / P36D-TTT P36A-GGG / P36A-TTT	400 (182) 560 (255) 700 (318) 740 (336)	36"x13.5"x37.5" 36"x41"x37.5" 36"x41"x37.5" 36"x41"x40.25"
48" griddle with 128,000 BTU		none cabinet standard convection	P48N-GGGG / P48N-TTTT P48C-GGGG / P48C-TTTT P48D-GGGG / P48D-TTTT P48A-GGGG / P48A-TTTT	500 (225) 660 (297) 800 (360) 840 (378)	48"x13.5"x37.5" 48"x41"x37.5" 48"x41"x37.5" 48"x41"x40.25"

Note: In the model number: "D" specifies standard oven and "A" specifies convection oven. "G" specifies manual griddle and "T" specifies thermostatic controls. Number of racks: standard oven has 2 racks and convection oven has 3 racks. Standard and Convection ovens are located on left side of 48" range with 12" cabinet on right.

# Planchas



P36C-PPP  
w/ optional casters & flue riser

Southbend Plancha units have a raised griddle plate for easy cleaning of cooking surface between loads. 3" wide collection on sides allow separation of waste for preparation of next fare. Plancha griddle is 1/2" thick reinforced steel plate powered by cast iron burners provides fast preheat and recovery time. High heat zone with max temperatures of 800°F located on front 2/3 of plate for quick sear with decreased temps on rear 1/3 of plate for product finishing.

- (1) 16,000 BTU burner for the 16" and 18" units
- (2) 16,000 BTU burners for the 24" unit
- (3) 16,000 BTU burners for the 32" and 36" units
- 1/2" thick polished griddle plate
- Manual controls
- Standard with battery spark ignition
- Stainless steel construction standard

## Planchas - Standard with battery spark ignition

Configuration		Oven Base	Model Number	Weight	Dimension WxHxD
16" plancha with 16,000 BTU		none cabinet	P16N-P P16C-P	240 (108) 270 (122)	16"x13.5"x37.5" 16"x41"x37.5"
18" plancha with 16,000 BTU		none cabinet	P18N-P P18C-P	250 (113) 280 (127)	18"x13.5"x37.5" 18"x41"x37.5"
24" plancha with 32,000 BTU		none cabinet	P24N-PP P24C-PP	300 (136) 330 (150)	24"x13.5"x37.5" 24"x41"x37.5"
32" plancha with 48,000 BTU		none cabinet standard convection	P32N-PPP P32C-PPP P32D-PPP P32A-PPP	400 (182) 560 (255) 700 (318) 740 (336)	32"x13.5"x37.5" 32"x41"x37.5" 32"x41"x37.5" 32"x41"x40.25"
36" plancha with 48,000 BTU		none cabinet standard convection	P36N-PPP P36C-PPP P36D-PPP P36A-PPP	400 (182) 560 (255) 700 (318) 740 (336)	36"x13.5"x37.5" 36"x41"x37.5" 36"x41"x37.5" 36"x41"x40.25"
48" plancha with 64,000 BTU		none cabinet standard convection	P48N-PPPP P48C-PPPP P48D-PPPP P48A-PPPP	400 (182) 560 (255) 700 (318) 740 (336)	48"x13.5"x37.5" 48"x41"x37.5" 48"x41"x37.5" 48"x41"x40.25"

Note: In the model number: "D" specifies standard oven and "A" specifies convection oven. "P" specifies manual plancha griddle. Number of racks: standard oven has 2 racks and convection oven has 3 racks.



# Induction Range







P36T-ISS  
(mounted on TVES/10SC)

Southbend induction units have (2) 3,500 WATT induction hobs every 12 inches. Induction ranges can be mounted on a standard oven base, convection-oven base, cabinet base, or as a modular unit (for mounting on countertop, refrigerated or freezer base).

- (2) 3,500 WATT induction hobs per 12" for high output
- 2, 4 and 6 hob configuration available per 36
- Multiple configurations of tops available to meet your cooking needs
- Can be installed over TruVection, convection, standard, or cabinet bases.
- 0-9 power level LED indicator per cooking hob shown on glass
- Removable, 12" coils for easy service
- High impact CERAN® glass top and easy to clean
- Automatic infrared shut-off sensor prevents overheating
- 9-1/4" deep front rail
- 100% stainless steel construction
- 1-1/4" front gas manifold and 1" rear gas connection for integration into batteries and suites
- 5" high stainless steel flue riser

## Induction Range

Configuration		Oven Base	Model Number	Weight	Dimension WxHxD
36" Induction Top with (2) 3,500 WATT hobs (2) 12" spreader		none cabinet TruVection	P36N-ISS P36C-ISS P36T-ISS	300 (136) 567 (257) 630 (272)	36"x19"x37.5" 36"x36"x41" 36"x36"x41"
36" Induction Top with (2) 3,500 WATT hobs (2) 12" spreader		none cabinet TruVection	P36N-SIS P36C-SIS P36T-SIS	300 (136) 567 (257) 630 (272)	36"x19"x37.5" 36"x36"x41" 36"x36"x41"
36" Induction Top with (4) 3,500 WATT hobs (1) 12" spreader		none cabinet TruVection	P36N-ISI P36C-ISI P36T-ISI	300 (136) 567 (257) 630 (272)	36"x19"x37.5" 36"x36"x41" 36"x36"x41"
36" Induction Top with (6) 3,500 WATT hobs		none cabinet TruVection	P36N-III P36C-III P36T-III	300 (136) 567 (257) 630 (272)	36"x19"x37.5" 36"x36"x41" 36"x36"x41"

Note: In the model number: "T" specifies TruVection base.

# Electric Range

Southbend Platinum Series now offers electric top options. Electric hotplates, griddles, and round hotplate tops are available. Platinum electric can be used as a standalone unit, mounted on a cabinet base, or paired with any of our oven base options.



PE36N-HHH



PE36N-TTT



PE36N-BBB

- Platinum front rail match
- (3) 5.3kw hotplates, thermostatically controlled
- 36" 16.5Kw griddle, thermostatically controlled
- (6) 15.6Kw round hotplates, low to high controlled
- Stainless steel construction

## Electric Range

Configuration		Oven Base	Model Number	Weight	Dimension WxHxD
(1) 12"x24" hotplates (5.3kW)		None Cabinet	PE12N-H PE12C-H	175 (79) 225 (102)	20"x21"x42.5" 20"x45"x42.5"
(2) 12"x24" hotplates (5.3kW/ea)		None Cabinet	PE24N-HH PE24C-HH	231 (105) 349 (158)	39"x21"x44" 39"x45"x44"
(3) 12"x24" hotplates (5.3kW/ea)		None Cabinet TruVection	PE36N-HHH PE36C-HHH PE36T-HHH	375 (170) 600 (272) 675 (306)	45.5"x23"x55" 45.5"x45"x55" 45.5"x45"x55"
(1) 12"x24" griddle (5.3kW)		None Cabinet	PE12N-T PE12C-T	175 (79) 225 (102)	20"x21"x42.5" 20"x45"x42.5"
(1) 24"x24" griddle (10.6kW)		None Cabinet	PE24N-TT PE24C-TT	250 (113) 330 (150)	39"x21"x44" 39"x45"x44"
(1) 36"x24" griddle (15.9kW)		None Cabinet TruVection	PE36N-TTT PE36C-TTT PE36T-TTT	375 (170) 601 (273) 675 (306)	45.5"x23"x55" 45.5"x45"x55" 45.5"x45"x55"
(2) round hotplates (2.6kW/ea)		None Cabinet	PE12N-B PE12C-B	130 (59) 200 (91)	20"x21"x44" 20"x45"x44"
(4) round hotplates (2.6kW/ea)		None Cabinet	PE24N-BB PE24C-BB	250 (113) 330 (150)	39"x21"x44" 39"x45"x44"
(6) round hotplates (2.6kW/ea)		None Cabinet TruVection	PE36N-BBB PE36C-BBB PE36T-BBB	390 (177) 600 (272) 675 (306)	45.5"x21"x44" 45.5"x45"x44" 45.5"x45"x55"

Note: In the model number: "D" specifies standard oven and "A" specifies convection oven. "T" specifies TruVection base.



# Uniform and Graduated Hot Top

## Graduated Hot Top

- 62,000 BTU burner
- Hi/Lo control setting
- Center operates at 1000°F
- Battery spark ignition
- Stainless steel construction standard



P36A-GRAD  
w/ optional casters & flue riser

## Uniform Hot Top

- 40,000 BTU burners every 16" (16" and 32" units)
- 32,000 BTU burners every 12" (12", 24", 36" and 48" units)
- Dual controls
- Battery spark ignition
- Stainless steel construction standard



P36D-FF  
w/ optional casters & flue riser

## Hot Tops - Standard with battery spark ignition







Configuration		Oven Base	Model Number	Weight	Dimension WxHxD
12" uniform hot top with 32,000 BTU		none cabinet	P12N-H P12C-H	130 (59) 180 (82)	12"x13.5"x37.5" 12"x41"x37.5"
16" uniform hot top with 40,000 BTU		none cabinet	P16N-H P16C-H	150 (68) 220 (100)	16"x13.5"x37.5" 16"x41"x37.5"
24" uniform hot top with 64,000 BTU		none cabinet	P24N-HH P24C-HH	205 (93) 280 (127)	24"x13.5"x37.5" 24"x41"x37.5"
32" uniform hot top with 80,000 BTU		none cabinet standard convection	P32N-HH P32C-HH P32D-HH P32A-HH	315 (143) 490 (223) 630 (286) 670 (305)	32"x13.5"x37.5" 32"x41"x37.5" 32"x41"x37.5" 32"x41"x40.25"
36" uniform hot top with 96,000 BTU		none cabinet standard convection	P36N-HHH P36C-HHH P36D-HHH P36A-HHH	346 (157) 523 (237) 629 (285) 682(309)	36"x13.5"x37.5" 36"x41"x37.5" 36"x41"x37.5" 36"x41"x40.25"
32" graduated hot top with 62,000 BTU		none cabinet standard convection	P32N-GRAD P32C-GRAD P32D-GRAD P32A-GRAD	315 (143) 490 (223) 630 (286) 670 (305)	32"x13.5"x37.5" 32"x41"x37.5" 32"x41"x37.5" 32"x41"x40.25"
36" graduated hot top with 62,000 BTU		none cabinet standard convection	P36N-GRAD P36C-GRAD P36D-GRAD P36A-GRAD	346 (157) 523 (237) 629 (285) 682 (309)	36"x13.5"x37.5" 36"x41"x37.5" 36"x41"x37.5" 36"x41"x40.25"
18" French top with 40,000 BTU		none cabinet	P18N-F P18C-F	240 (108) 270 (123)	18"x13.5"x37.5" 18"x41"x37.5"
36" (2) 18" French tops 40,000 BTU		none cabinet standard convection	P36N-FF P36C-FF P36D-FF P36A-FF	346 (157) 523 (237) 629 (285) 682 (309)	36"x13.5"x37.5" 36"x41"x37.5" 36"x41"x37.5" 36"x41"x40.25"

Note: In the model number: "D" specifies standard oven and "A" specifies convection oven. Number of racks: standard oven has 2 racks and convection oven has 3 racks.

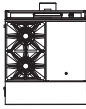

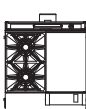
# Combination Tops

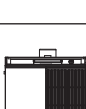
## Combination Tops - 32"

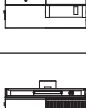
Configuration		Oven Base	Model Number	Weight	Dimension WxHxD
32" range Top with 2 -45,000 BTU open top burners and 16" hot top.		none cabinet standard convection	P32N-XH P32C-XH P32D-XH P32A-XH	300 (136) 440 (200) 570 (259) 710 (322)	32"x13.5"x37.5" 32"x41"x37.5" 32"x41"x37.5" 32"x41"x40.25"
32" range Top with 2 -45,000 BTU open top burners and 16" hot top in rear.		none cabinet standard convection	P32N-XH-RE P32C-XH-RE P32D-XH-RE P32A-XH-RE	300 (136) 440 (200) 570 (259) 710 (322)	32"x13.5"x37.5" 32"x41"x37.5" 32"x41"x37.5" 32"x41"x40.25"
32" range Top with 2 -45,000 BTU open top burners and 16" griddle.		none cabinet standard convection	P32N-XG / P32N-XT P32C-XG / P32C-XT P32D-XG / P32D-XT P32A-XG / P32A-XT	390 (177) 490 (222) 660 (300) 800 (363)	32"x13.5"x37.5" 32"x41"x37.5" 32"x41"x37.5" 32"x41"x40.25"
32" range Top with 2 -45,000 BTU open top burners and 16" charbroiler.		none cabinet standard convection	P32N-XC P32C-XC P32D-XC P32A-XC	300 (136) 440 (200) 570 (259) 710 (322)	32"x13.5"x37.5" 32"x41"x37.5" 32"x41"x37.5" 32"x41"x40.25"
32" range Top with 16" hot top and 16" charbroiler.		none cabinet standard convection	P32N-HC P32C-HC P32D-HC P32A-HC	300 (136) 440 (200) 570 (259) 710 (322)	32"x13.5"x37.5" 32"x41"x37.5" 32"x41"x37.5" 32"x41"x40.25"
32" range Top with 16" hot top and 16" griddle.		none cabinet standard convection	P32N-HG / P32N-HT P32C-HG / P32C-HT P32D-HG / P32D-HT P32A-HG / P32A-HT	390 (177) 490 (223) 660 (300) 800 (363)	32"x13.5"x37.5" 32"x41"x37.5" 32"x41"x37.5" 32"x41"x40.25"
32" range Top with 16" griddle and 16" charbroiler.		none cabinet standard convection	P32N-GC / P32N-TC P32C-GC / P32C-TC P32D-GC / P32D-TC P32A-GC / P32A-TC	390 (177) 490 (223) 660 (300) 800 (363)	32"x13.5"x37.5" 32"x41"x37.5" 32"x41"x37.5" 32"x41"x40.25"

Note: In the model number: "D" specifies standard oven and "A" specifies convection oven. "G" specifies manual griddle and "T" specifies thermostatic controls. Number of racks: standard oven has 2 racks and convection oven has 3 racks.

Specify top configurations "R" right or "L" left when ordering.



## Combination Tops - 36"

Configuration	Oven Base	Model Number	Weight	Dimension WxHxD
36" range Top with 2 -35,000 BTU open top burners and 24" hot top.	none cabinet standard convection	P36N-BHH P36C-BHH P36D-BHH P36A-BHH	300 (136) 440 (200) 570 (259) 710 (322)	36"x13.5"x37.5" 36"x41"x37.5" 36"x41"x37.5" 36"x41"x40.25"
36" range Top with 4 -35,000 BTU open top burners and 12" hot top	none cabinet standard convection	P36N-BBH P36C-BBH P36D-BBH P36A-BBH	300 (136) 440 (200) 570 (259) 710 (322)	36"x13.5"x37.5" 36"x41"x37.5" 36"x41"x37.5" 36"x41"x40.25"
36" range Top with 2 -35,000 BTU open top burners and 24" griddle.	none cabinet standard convection	P36N-BGG / P36N-BTT P36C-BGG / P36C-BTT P36D-BGG / P36D-BTT P36A-BGG / P36A-BTT	390 (177) 490 (222) 660 (300) 800 (363)	36"x13.5"x37.5" 36"x41"x37.5" 36"x41"x37.5" 36"x41"x40.25"
36" range Top with 4 -35,000 BTU open top burners and 12" griddle.	none cabinet standard convection	P36N-BBG P36C-BBG P36D-BBG P36A-BBG	300 (136) 440 (200) 570 (259) 710 (322)	36"x13.5"x37.5" 36"x41"x37.5" 36"x41"x37.5" 36"x41"x40.25"
36" range Top with 2 -35,000 BTU open top burners and 24" charbroiler.	none cabinet standard convection	P36N-BCC P36C-BCC P36D-BCC P36A-BCC	300 (136) 440 (200) 570 (259) 710 (322)	36"x13.5"x37.5" 36"x41"x37.5" 36"x41"x37.5" 36"x41"x40.25"
36" range Top with 4 -35,000 BTU open top burners and 12" charbroiler.	none cabinet standard convection	P36N-BBC P36C-BBC P36D-BBC P36A-BBC	390 (177) 490 (223) 660 (300) 800 (363)	36"x13.5"x37.5" 36"x41"x37.5" 36"x41"x37.5" 36"x41"x40.25"
36" range Top with 24" griddle and 12" charbroiler.	none cabinet standard convection	P36N-GGC / P36N-TTC P36C-GGC / P36C-TTC P36D-GGC / P36D-TTC P36A-GGC / P36A-TTC	390 (177) 490 (223) 660 (300) 800 (363)	36"x13.5"x37.5" 36"x41"x37.5" 36"x41"x37.5" 36"x41"x40.25"
36" range Top with 24" plancha and 12" charbroiler.	none cabinet standard convection	P36N-PPC P36C-PPC P36D-PPC P36A-PPC	390 (177) 490 (223) 660 (300) 800 (363)	36"x13.5"x37.5" 36"x41"x37.5" 36"x41"x37.5" 36"x41"x40.25"

Note: In the model number: "D" specifies standard oven and "A" specifies convection oven. "G" specifies manual griddle and "T" specifies thermostatic controls. Number of racks: standard oven has 2 racks and convection oven has 3 racks.

Specify top configurations "R" right or "L" left when ordering.

**Additional combination top configurations may require additional lead times.  
Please contact customer service (919)-762-1000**

## Stock Pot Range

Configuration	Oven Base	Model Number	Weight	Dimension WxHxD
Single Stock Pot Range 120,000 BTU	none	SPR-1J	90 (41)	18"x24"x22.5"
Double Stock Pot Range 240,000 BTU	none	SPR-2J	165 (75)	36"x24"x22.5"
Double Stock Pot Range 90,000 BTU	none	SPR-2J-FB	175 (80)	18"x24"x40.5"

## Platinum Options and Accessories - Gas Regulators

Gas Regulators - Options and Accessories	Part Number
1" Gas regulator, natural gas -preset @ 6". max capacity 600,000 BTU *	1167782
1" Gas regulator, LP gas -preset @ 10". max capacity 600,000 BTU *	1167783
1 1/4" Gas regulator, natural gas -preset @ 6". max capacity 2,500,000 BTU *	4450009
1 1/4" Gas regulator, LP gas -preset @ 10". max capacity 2,500,000 BTU *	4450010
1" Gas shut-off valve	4450007
1 1/4" Gas shut-off valve for sectional batteries	4450008
1" Quick disconnect with 48" flex hose	1130195
1" Quick disconnect with 60" flex hose	1130194
Restraining device	1176867

\* ALL stand alone sectional units require 1" NPT gas pressure regulators. Batteried units must have appropriate quantity of 1" NPT gas pressure regulators for adequate supply pressure.

## Spreader Cabinets

Model Number	Width	Base	Weight	Dimension WxHxD
P12N-S	12"	none	100 (45)	12"x13.5"x37.5"
P12C-S	12"	cabinet	121 (54)	12"x41"x37.5"
P16N-S	16"	none	110 (49)	16"x13.5"x37.5"
P16C-S	16"	cabinet	131 (60)	16"x41"x37.5"
P18N-S	18"	none	120 (63)	18"x13.5"x37.5"
P18C-S	18"	cabinet	141 (64)	18"x41"x37.5"
P24N-SS	24"	none	150 (68)	24"x13.5"x37.5"
P24C-SS	24"	cabinet	180 (81)	24"x41"x37.5"
P32N-SS	32"	none	185 (83)	32"x13.5"x37.5"
P32C-SS	32"	cabinet	220 (99)	32"x41"x37.5"
P36N-SSS	36"	none	220 (99)	36"x13.5"x37.5"
P36C-SSS	36"	cabinet	260 (117)	36"x41"x37.5"

"T" gas connection for utility cabinet includes 1-1/4" regulator and shut-off.....\$4,484

For special size spreader cabinets, up to 72" wide, use price of next largest size and add \$954

Example: A 8"W spreader cabinet with a cabinet base would be model number P8C-S. (The price of P8C-S would be equal to P12C-S plus \$954).

Custom size spreader cabinets require additional lead times. Please contact customer service, 919-762-1000. 8" minimum width.

## Support and Caster Frames

Model Number	Width	Weight
<b>Caster Frames for Oven/Cabinet Base</b>		
PCF48	48"	90 (41)
PCF64	64"	142 (65)
PCF72	72"	165 (75)
PCF80	80"	174 (79)
PCF96	96"	210 (95)
For special size frames, up to 96" wide: use price of next largest and add \$545		
<b>28" High Stands for Modular Units</b>		
<b>NO SHELF</b>	<b>WITH SHELF</b>	
PL24	PL/24	24" 88 (40)
PL32	PL/32	32" 94 (43)
PL36	PL/36	36" 150 (69)
PL48	PL/48	48" 198 (91)
PL60	PL/60	60" 210 (95)
PL64	PL/64	64" 222 (100)
PL72	PL/72	72" 245 (112)
<b>Castors for Modular Stands</b>		
24", 32", 36", 48"		
60", 64", 72"		

Caster frame will add 1" to working height of supported units. Custom support and caster frames require additional lead times. Please contact customer service.



## Flue Risers

Model Number	Width	Weight	Dimension WxH
<b>5" Flue Risers - Standard (excluding fryers)</b>			
<b>24" High Flue Risers</b>			
PR24-12	12"	30 (14)	12"x24"
PR24-16	16"	31 (14)	16"x24"
PR24-18	18"	31 (14)	18"x24"
PR24-20	20"	32 (15)	20"x24"
PR24-24	24"	33 (15)	24"x24"
PR24-32	32"	55 (25)	32"x24"
PR24-36	36"	62 (28)	36"x24"
PR24-48	48"	80 (37)	48"x24"
PR24-60	60"	86 (39)	60"x24"
PR24-64	64"	92 (41)	64"x24"
PR24-72	72"	102 (46)	72"x24"
<b>36" High Flue Risers</b>			
PR36-12	12"	20 (9)	12"x36"
PR36-16	16"	30 (14)	16"x36"
PR36-18	18"	30 (14)	18"x36"
PR36-20	20"	33 (15)	20"x36"
PR36-24	24"	38 (17)	24"x36"
PR36-32	32"	55 (25)	32"x36"
PR36-36	36"	62 (28)	36"x36"
PR36-48	48"	80 (37)	48"x36"
PR36-60	60"	138 (62)	60"x36"
PR36-64	64"	92 (41)	64"x36"
PR36-72	72"	102 (46)	72"x36"

For special width flue risers, up to 72" wide, use price of next largest width and add \$842 Example: A 24"H x 40"W flue riser would be model number PR24-48 for \$2,926 + \$842 (the price of the PR24-48 flue riser plus \$842).

Contact customer service, 919-762-1000, for special height flue risers.

Additional Options: Double hinged range faucet/pot filler (add to list of flue riser)\* .....\$4,080

Custom flue risers require additional lead times. Please contact service, 919-762-1000. Available over 35,000 BTU burners only.

\*mounted on 36" high flue risers without shelving only.

## Shelving

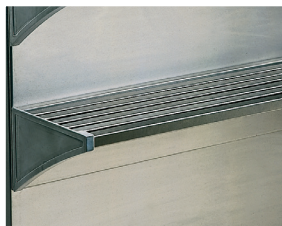

(tubed shelving)



(tray shelving)

Model Number	Width	Weight	Dimension WxH
<b>SINGLE</b>			
PRS24-12	12"	41 (19)	12"x24"
PRS24-16	16"	45 (21)	16"x24"
PRS24-18	18"	50 (24)	18"x24"
PRS24-24	24"	59 (27)	24"x24"
PRS24-32	32"	59 (27)	32"x24"
PRS24-36	36"	83 (38)	36"x24"
PRS24-48	48"	90 (41)	48"x24"
PRS24-60	60"	99 (45)	60"x24"
PRS24-64	64"	108 (48)	64"x24"
PRS24-72	72"	129 (57)	72"x24"
<b>DOUBLE</b>			
PRS36-12	12"	59 (27)	12"x36"
PRS36-16	16"	68 (31)	16"x36"
PRS36-18	18"	72 (33)	18"x36"
PRS36-24	24"	79 (35)	24"x36"
PRS36-32	32"	85 (39)	32"x36"
PRS36-36	36"	100 (45)	36"x36"
PRS36-48	48"	127 (58)	48"x36"
PRS36-60	60"	138 (62)	60"x36"
PRS36-64	64"	150 (68)	64"x36"
PRS36-72	72"	180 (81)	72"x36"

Solid shelving is standard. Add \$785 per shelf for tray or tubed shelving (specify when ordering)



Range Base Options and Accessories	
<b>Oven-Based Ranges</b>	
Stainless steel rear (32" units)	
Stainless steel exterior bottom	
Stainless steel oven burner box bottom and sides	
Stainless steel oven interior and porcelain oven bottom	
Electronic ignition in lieu of standing pilot (oven base only)	
650°F oven thermostat (standard oven only)	
<b>Cabinet-Based Ranges</b>	
Stainless steel rear (32" through 48" units)	
Stainless steel rear (12" through 24" units)	
Stainless steel exterior bottom	
Less doors (half sections)	
Stainless steel intermediate shelf	
<b>Table Top Ranges</b>	
Stainless steel rear	
Stainless steel exterior bottom	
Insulated base (for units in the field)	
4" legs (set of 4)	
<b>Low Boy Cabinet (26" high on 6" legs or casters)</b>	
P12C-L	
P24C-L	
P36C-L	
<b>Electric Ranges</b>	
480v increase	
Range Top Options and Accessories	
<b>Griddle Options:</b>	
48" overlapping (includes continuous front rail)	
60" overlapping (includes continuous front rail)	
64" overlapping (includes continuous front rail)	
72" overlapping (includes continuous front rail)	
12" grooved	<b>Requires additional lead time. Please contact customer service 919-762-1000</b>
24" grooved	
36" grooved	
48" grooved	
24" chrome	
32" chrome	
36" chrome	
48" chrome	
60" chrome	
64" chrome	
<b>Charbroiler Options:</b>	
48" overlapping (includes continuous front rail)	
60" overlapping (includes continuous front rail)	
64" overlapping (includes continuous front rail)	
72" overlapping (includes continuous front rail)	
6" round rod grate	
12" round rod grate	
16" round rod grate	
Plated fish grids -6" sections	
Replacement briquettes - 5 lbs. bags	
Stainless steel burner box bottom, sides, and drip tray	
<b>Modular Top Options:</b>	
Stainless steel burner box bottom, sides, and drip tray	



## Sectional Options and Accessories

Options and Accessories
Deep ranges – Add to standard range prices
Sectional open top units: Flame failure and battery spark ignition per each two burners section, 12", 16" and 18"
Battery Spark Ignition
12" - 18" wide
24" wide
32" - 36" wide
48" wide
Open Tops
Convert Open Top Burner to stainless steel work top
Convert Pyromax Open Top Burner to stainless steel work top
Convert rear burners to Hot Top (36" six burner ranges only)
Convert welded steel grates to cast
Continuous Front Rails
Length in inches x \$26 (108" maximum) - (requires additional lead time. Not available across spreader tops)
Front rail with full opening for 1/9th size sauce pans (pans by others).
12" wide - 2 pans
16" wide - 2 pans
24" wide - 3 pans
32" wide - 4 pans
36" wide - 5 pans
48" wide - 6 pans
Square belly bar ( mounts on 7.25" front rail)
7.25" front rail (to match old style sectional unit)
Extended plate shelf with cutting board
Extended plate shelf without cutting board
Enclosures
Stainless steel enclosures under shelves:
24" wide
32" wide
36" wide
Oven Racks and Casters
Extra chrome plated oven rack
4" casters in lieu of legs
6" casters in lieu of legs
Bolt down flanged feet

Mount any Platinum 36" modular unit on a single deck TruVection.  
Factory installed at no charge.

See Page 53 for additional info on TruVection.

P36N-BBB mounted  
on a TVGS/12SC



# Remote Refrigerator and Freezer Bases

## Standard Features

- A variety of sizes available
- Expansion valve
- Stainless steel top, front, sides, back, drawers, and interior cavity
- Adjustable digital thermostat
- Self-closing, heavy-duty drawers slide on stainless steel rollers
- Removable door assembly
- Rubber, magnetic door gaskets provide a positive seal and easy cleaning
- 6" adjustable, stainless steel legs



## Remote Refrigerator and Freezer Bases

Remote Refrigerated Bases						
Model Number	Size	# of Drawers			Weight	Dimension WxHxD
		18"	26"	31"		
20032RSB	32"	-	2	-	325 (147)	32"x26"x32.5"
20036RSB	36"	-	2	-	340 (154)	36"x26"x32.5"
20048RSB	48"	-	-	2	400 (181)	48"x26"x32.5"
20060RSB	60"	2	2	-	530 (240)	60"x26"x32.5"
20064RSB	64"	2	2	-	585 (265)	64"x26"x32.5"
20072RSB	72"	-	2	2	637 (289)	72"x26"x32.5"
20084RSB	84"	2	2	-	735 (333)	84"x26"x32.5"
20096RSB	96"	-	6	-	835 (378)	96"x26"x32.5"
20108RSB	108"	-	2	4	940 (426)	108"x26"x32.5"
Remote Freezer Bases						
Model Number	Size	# of Drawers			Weight	Dimension WxHxD
		18"	26"	31"		
30032RSB	32"	-	2	-	325 (147)	32"x26"x32.5"
30036RSB	36"	-	2	-	340 (154)	36"x26"x32.5"
30048RSB	48"	-	-	2	400 (181)	48"x26"x32.5"
30060RSB	60"	2	2	-	530 (240)	60"x26"x32.5"
30064RSB	64"	2	2	-	585 (265)	64"x26"x32.5"
30072RSB	72"	-	2	2	637 (289)	72"x26"x32.5"
30084RSB	84"	4	2	-	735 (333)	84"x26"x32.5"
30096RSB	96"	-	6	-	835 (378)	96"x26"x32.5"
30108RSB	108"	-	2	4	940 (426)	108"x26"x32.5"

## Top view showing extended drawers

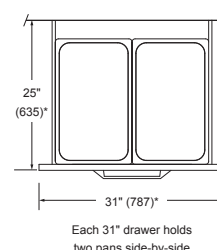
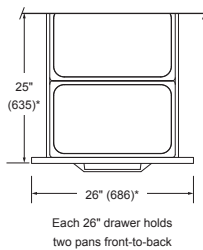
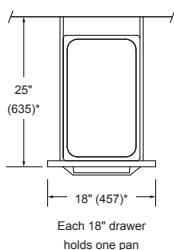

# Self Contained Refrigerator and Freezer Bases

## Standard Features

- A variety of sizes available
- Expansion valve
- Stainless steel top, front, sides, back, drawers, and interior cavity
- Self-closing, heavy-duty drawers slide on stainless steel rollers
- Removable door assembly



Self Contained Refrigerated Bases						
Model Number	Size	# of Drawers			Weight	Dimension WxHxD
		18"	26"	31"		
20032SB	32"	2	-	-	325 (147)	32"x26"x32.5"
20036SB	36"	2	-	-	340 (154)	36"x26"x32.5"
20048SB	48"	-	2	-	410 (186)	48"x26"x32.5"
20060SB	60"	-	-	2	550 (249)	60"x26"x32.5"
20064SB	64"	-	-	2	600 (272)	64"x26"x32.5"
20072SB	72"	-	4	-	650 (295)	72"x26"x32.5"
20084SB	84"	-	-	4	745 (338)	84"x26"x32.5"
20096SB	96"	2	4	-	855 (388)	96"x26"x32.5"
20108SB	108"	-	6	-	960 (435)	108"x26"x32.5"
20120SB	120"	4	4	-	1075 (488)	120"x26"x32.5"

Self Contained Freezer Bases						
Model Number	Size	Set of Drawers			Weight	Dimension WxHxD
		18"	21"	31"		
30032SB	32"	2	-	-	325 (147)	32"x26"x32.5"
30036SB	36"	2	-	-	340 (154)	36"x26"x32.5"
30048SB	48"	-	2	-	410 (186)	48"x26"x32.5"
30060SB	60"	-	-	2	550 (249)	60"x26"x32.5"
30064SB	64"	-	-	2	600 (272)	64"x26"x32.5"
30072SB	72"	-	4	-	650 (295)	72"x26"x32.5"
30084SB	84"	-	-	4	745 (338)	84"x26"x32.5"
30096SB	96"	2	4	-	855 (388)	96"x26"x32.5"
30108SB	108"	-	6	-	960 (435)	108"x26"x32.5"
30120SB	120"	4	4	-	1075 (488)	120"x26"x32.5"

## Refrigerator/Freezer Base Options and Accessories

Options and Accessories
12" Low Boy Cabinet (26" high on 6" legs or casters) P12C-L
24" Low Boy Cabinet (26" high on 6" legs or casters) P24C-L
36" Low Boy Cabinet (26" high on 6" legs or casters) P36C-L
Set of 4 casters for 32", 36", and 48" base
Set of 6 casters for 60", 64", 72", 84" and 96" base
Set of 8 casters for 108" and 120" base
Pricing below is for the optional 2" high insulated base when mounting Platinum countertop units on another manufacturer's refrigerated or freezer base in the field. <b>See NOTE below</b>
24" or 36"
48"
60"
72"
84"

NOTE: Platinum Series countertop units include the 2" high insulated base(s) at no charge when mounted to a SOUTHBEND refrigerated or freezer base at our factory. Additional lead time required (contact customer service: 919-762-1000). Units can be crated separately if required.



# Sectional Match Fryers

## Standard Features

- 45 lb. capacity
- Stainless steel tank, front sides and rear
- Two twin-plated, mesh fry baskets with plastic coated, heat resistant handles
- Quick recovery to eliminate waiting between loads
- 1 1/4" full pot drain valve to eliminate clogs
- 100% safety shut-off
- 17" flue riser required

Description	Model Number	Weight
45 lb. Sectional Match Fryer - 110,000 BTU	P16C-PF45	210 (95)
Built in Filter System		
Drain cabinet base	P16C-DC	153 (70)



P16C-PF45  
w/ optional casters

## Sectional Fryer Options and Accessories

Options and Accessories
17" stainless steel divider
Heat lamp

## Flue Risers

24" Height Minimum Flue Riser Required For Sectional Fryers

Model Number	Width	Weight	Dimension WxH
PR24-16	16"	31 (14)	16"x24"
PR24-20	20"	32 (15)	20"x24"
PR36-16	16"	30 (14)	16"x36"
PR36-20	20"	33 (15)	20"x36"





# Broilers

---

Southbend has over 115 years of experience in this industry. That experience is best illustrated with our broilers, an industry standard for over 40 years which can be found in some of the finest and most prestigious restaurants and steakhouses in the world.

In the hectic environment of today's steakhouses, you need three things from your equipment: speed, consistency and durability. We offer some of the hottest broilers in the market. Our higher BTU's from our infrared or radiant broilers offer an unparalleled evenness of cooking.

Our heavy-duty construction can take whatever your kitchen dishes out. A hand built stainless steel frame construction is durable enough to take the punishing demands of a busy restaurant, night after night.

Our new electric broilers are equipped with high-tech features that make cooking a breeze. Electric cooking has the ability to reduce carbon emissions by 75% or more over gas appliances.

# Upright Broilers



270  
w/ optional casters

## Standard Features

- Available in Radiant, Infrared, and Electric
  - Burner tile guard
  - Stainless steel front, top and sides
  - Highest capacity in smallest footprint
  - Round grids - great for meat marking
  - Removable grids for easy cleaning
  - Power blower - gas models
  - Removable grease drawer
  - Washable stainless steel air filters and grease filtration system
  - 3/4" rear gas connection - Sectional Match units have a 1" rear gas connection and a 1-1/4" front gas manifold
  - Available in single and double decks
  - Available with warming ovens or can be mounted on Standard and Convection Oven bases
- \* See specification sheet for installation details

## HEATING SOURCES



Infrared Burners  
-Gas-  
Max Temp: 1650°F



Radiant Burners  
-Gas-  
Max Temp: 1000°F

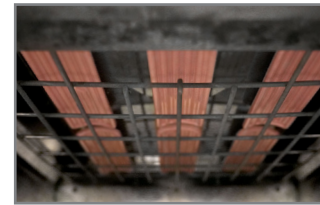

Ceramic Infrared Elements  
-Electric-  
Max Temp: 1000°F

# #1 CHOICE

of Famous Steakhouse Restaurants Around The Globe!

## Competitive Information

Standard Features:	Southbend 171	Garland M100XR	Montague 136W36	Vulcan VBB1F	Jade JSHBI-36H
Stainless steel front & sides	Yes	Yes	No	Yes	Yes
Two removable racks	Yes	Yes	Yes	No	Yes
<b>PATENTED</b> , high-power multidirectional burners for better heat distribution.	Yes	No	No	No	No
Total BTU output	104,000	70,000	124,000	100,000	104,000
Air filtration screen	Yes	No	No	No	No
Power blower	Yes	Yes	No	Yes	Yes
Optional warming oven	Yes	Yes	Yes	Yes	Yes
8" Rack-stop	Yes	No	No	No	No
Optional oven base	Yes	Yes	Yes	Yes	Yes



# Electric Upright Broilers

Our electric broilers are equipped with high-tech features that make cooking a breeze. Electric cooking has the ability to reduce carbon emissions by 75% or more over gas appliances. This electric broiler allows you to cook steaks and burgers while reducing your carbon footprint, without sacrificing food quality or control.



E-170  
(Single Deck)



E-270  
(Double Deck)

## WHAT YOU'LL LOVE:

- 1000°F Top Rack Position Temp
- Increased Energy Efficiency
- No Flare-ups - No Fumes
- Same footprint, Same Capacity as Gas Models

## Standard Features

- Stainless steel front, sides and back panel
- 12 kW ceramic infrared heating elements - per rack
- 30 minute preheat with no waiting between loads
- Rugged grid height adjustment mechanism with five positions
- Roll-out broiling area is 24-1/2" wide and 27-1/2" deep, with a reduced heat holding area in the front 3"
- Fully insulated lining and burner boxes
- Removable grids with a round pattern for branding
- 6" adjustable stainless steel legs
- Model E-171 has a warming oven that is heated by 3,000 watt heating element.

## Electric Upright Infrared Broilers

Configuration	Model Number	Weight	Dimension WxHxD
Single deck electric broiler - 12 kW heating elements	E-170	618 (280)	34"x63.5"x39"
Double deck electric broiler - 24 kW elements	E-270	931 (423)	34"x75.5"x39"

# 24" Electric Broiler

Limited on space but want the efficiency and experience of a full-size electric broiler? Our Electric Counterline Broiler is the solution for you. Providing high heat for evenly cooking steaks with the results of a full-size broiler, in one compact unit.



HDEB-24-316L  
(Single Deck)

## WHAT YOU'LL LOVE:

- 1000°F Top Rack Position Temp
- Increased Energy Efficiency
- No Flare-ups - No Fumes
- Same footprint, Same Capacity as Gas Models

## Standard Features

- 100% 316L Stainless steel construction
- Explicitly designed for catering/outdoor applications
- 6 kW ceramic infrared heating elements
- 30 minute preheat with no waiting between loads
- Roll-out broiling area is 16" wide and 26-1/2" deep, with a reduced heat holding area in the front 3"
- Rugged grid height adjustment mechanism with five positions
- Removable grids with a round pattern for branding
- Fully insulated lining and burner boxes
- Counter mount base for use with legs or mount on stand

## 24" Electric Broiler

Configuration	Model Number	Weight	Dimension WxHxD
24" upright electric broiler with 316L Stainless Steel - 6 kW	HDEB-24-316L	525 (238)	24"x44"x44"



# Upright Radiant Broilers - Sectional Match

Our Sectional-Match Radiant Broiler is designed for searing a diverse range of product from chicken to seafood and steaks in the broiler deck and finishing, carrying over to the final temp or basting in the warming oven.



P32D-3240

## Standard Features

- Warming oven -heated by broiler flue gases (25" wide x 25" deep)
- 110,000 BTU NAT (90,000 BTU LP) two broiler burners with separate controls
- 15 minute preheat
- Removable drip drawer
- Rugged grid height adjustment mechanism with four positions
- Fully insulated lining and burner boxes
- Broiler grid is 24-1/2" wide and 28" deep - easily rolls out 17-1/4"
- 1-1/4" front manifold and rear gas connection standard
- Stainless steel front, sides and back
- 6" adjustable stainless steel legs

## Oven Base Features

- 45,000 BTU NAT/LP oven with electronic pilot ignition
- "Insta-On" thermostat ranging from 175°F to 550°F
- Cool-to-the-touch handle
- Porcelain enamel interior
- 2 oven racks with Standard Oven and 3 racks with Convection Oven
- Standard oven interior is large enough to fit 26" x 26" sheet pan either way
- Convection oven models have 1/2hp, two speed blower
- NEMA 4 water resistant controls

## Cabinet Base Features

- Stainless steel cabinets with dual side by side removable doors

## Upright Radiant Broilers - Sectional Match

Configuration	Model Number	Weight	Dimension WxHxD
Sectional Match, single deck radiant broiler with warming oven and cabinet base - 110,000 BTU	P32C-32B	955 (434)	32"x75"x39"
Sectional Match, single deck radiant broiler with warming oven and standard oven base - 142,000 BTU	P32D-3240	995 (447)	32"x75"x39"
Sectional Match, single deck radiant broiler with warming oven and convection oven base - 142,000 BTU	P32A-3240	995 (447)	32"x75"x40.75"

# Upright Infrared Broilers - Sectional Match

Our Sectional-Match Infrared Broiler is perfect for searing product in the deck to finish, carrying over to the final temp, or basting in the warming oven. Broil, roast, and carry over your steak needs with our unique broiler solution.



P32D-171

## Standard Features

- 104,000 BTU (NAT or LP) infrared burners
- 90 second preheat with no waiting between loads
- Rugged grid height adjustment mechanism with four positions
- Fully insulated lining and burner boxes
- Broiler grid is 24-1/2" wide and 28" deep - easily rolls out 17-1/4"
- 1-1/4" front manifold and rear gas connection standard
- Warming oven that is heated by broiler flue gases (25" wide x 25" deep). 3,000 watt electric heating element optional.
- Stainless steel front, sides and back
- 6" adjustable stainless steel legs

## Oven Base Features

- 45,000 BTU NAT/LP oven with electronic pilot ignition
- "Insta-On" thermostat ranging from 175°F to 550°F
- Cool-to-the-touch handle
- Porcelain enamel interior
- 2 oven racks with Standard Oven and 3 racks with Convection Oven
- Standard oven interior is large enough to fit 26" x 26" sheet pan either way
- Convection oven models have 1/2hp, two speed blower
- NEMA 4 water resistant controls

## Cabinet Base Features

- Stainless steel cabinets with dual side by side removable doors

## Upright Infrared Broilers - Sectional Match

Configuration	Model Number	Weight	Dimension WxHxD
Sectional Match, single deck infrared broiler with warming oven and cabinet base - 104,000 BTU	P32C-171	900 (405)	32"x81"x39"
Sectional Match, single deck infrared broiler with warming oven and standard oven base - 149,000 BTU	P32D-171	995 (447)	32"x81"x39"
Sectional Match, single deck infrared broiler with warming oven and convection oven base - 149,000 BTU	P32A-171	995 (447)	32"x81"x40.75"
Sectional Match, single deck infrared broiler with warming oven and no base - 104,000 BTU	P32N-171	800 (363)	32"x52"x37"



# Upright Broilers - Infrared & Radiant



270



171



170

Our broilers have the highest capacity in the industry, heating up in just 90 seconds with no recovery between rounds of production. Large-capacity cooking grids increase efficiency and save time.

### Standard Features

- Faster broiling times with 1/3 less time
- Blower delivers fresh, filtered air to prevent smoke and vapors from affecting broiling efficiency
- 90 second preheat with no waiting between loads
- 104,000 BTU (NAT or LP) infrared burners (per deck)
- Washable metal mesh air filter
- Rugged grid height adjustment mechanism with five positions
- Roll-out broiling area is 24-1/2" wide and 27-1/2" deep, with a reduced heat holding area in the front 3"
- Fully insulated lining and burner boxes
- Removable grids with a round pattern for branding
- Stainless steel front, sides and back panel
- 6" adjustable stainless steel legs

Model 171 has a warming oven that is heated by broiler flue gases (25" wide x 25" deep). 3,000 watt electric heating element optional.

## Upright Infrared Broilers

Configuration	Model Number	Weight	Dimension WxHxD
Single deck infrared broiler - 104,000 BTU	170♦	618 (280)	34"x63.5"x39"
Single deck infrared broiler with warming oven - 104,000 BTU	171♦	693 (314)	34"x74"x39"
Double deck infrared broiler - 208,000 BTU	270♦	931 (423)	34"x75.5"x39"

♦Contact factory for more details.



234R

### Standard Features

- 110,000 BTU NAT (90,000 BTU LP) two broiler burners with separate controls per deck
- Removable drip drawer
- Rugged grid height adjustment mechanism with four positions
- 2" Flue Collar
- Interior shelving made of high-heat aluminized steel
- Broiler grid is 24-1/2" wide and 28" deep -easily rolls out 17-1/4" - the front 3" receive less heat so can be used as a holding area
- Stainless steel front, sides, top and legs
- 6" adjustable stainless steel legs

## Upright Radiant Broilers

Configuration	Model Number	Weight	Dimension WxHxD
Double deck radiant broiler 220,000 BTU	234R	932 (423)	34"x74.5"x39"



# Steakhouse Broiler

Southbend has topped it's heavy-duty radiant broiler by adding a griddle searing plate for the perfect Steakhouse Broiler.



SSB-36  
w/ standard stand & optional casters

## Standard Features

- Stainless steel cradle and carriage construction
- Stainless steel front, sides and back
- Patent pending rack adjust mechanism, nine positions with paddle release
- Removable 2-1/2 quart griddle grease catch
- Removable 7-3/4 quart broiler grease drawer
- 1/2" thick quick recovery searing griddle (heated with broiler flue gas)
- 4" griddle splash guards
- Independent variable adjust burner control valves
- Smooth track dura-glide meat rack with concealed roller bearings
- Chrome plated cooking grids
- Equipment stand with lower shelf
- Mounting options include flashed countertop, cabinet base, refrigerated and/or freezer base
- 1-1/4" front manifold with 1" rear gas supply connection
- 6" adjustable legs or 6" adjustable casters (except counter top models)

## Steakhouse Broiler

Model Number	Total BTUs NAT(LP)	Weight	Dimensions (Including Stand) W x H x D
SSB-32	84,000(74,000)	429 (195)	32"x57"x38.75"
SSB-36	84,000(74,000)	665 (302)	36"x57"x38.75"
SSB-45	126,000(111,000)	831 (377)	45"x57"x38.75"

Optional 6" Casters Available \$819 (adjustable legs standard)

## Broiler Options and Accessories

Options and Accessories
1" pressure regulator (Sectional Match)
Extra plated oven rack
Stainless steel flue diverter
4" or 6" Casters in lieu of legs
Stainless steel rear (Sectional Match)
Electric heating element for warming oven (Infrared broilers only)



# Compact Salamander

## P 32-NFR

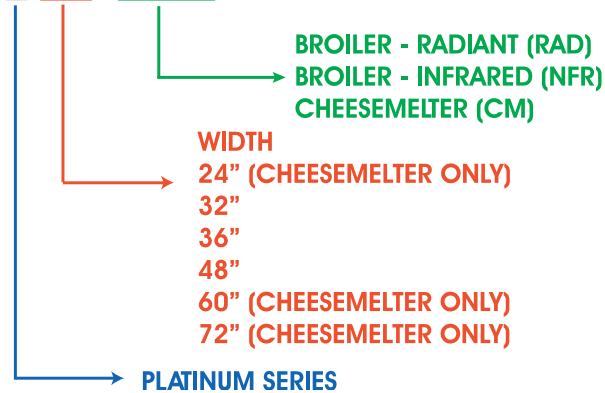

P36-NFR

### What is a Salamander?

An overfired broiler designed to broil food directly on the adjustable cooking rack.

### What are Infrared and Radiant burners?

**Infrared burners** are an intense heat source that uses infrared light from gas burners to broil food.

**Radiant Burners** are an enveloping heat source that uses steel radiant's to radiate heat and broil the food.

### Standard Features

- Broilers available in 32", 36", and 48"
- Cheesemelters available in 24", 32", 36", 48", 60" and 72"
- Dual valve control for left and right operation
- 40,000 BTU on the 32" and 36", and 60,000 BTU on the 48" and 60", and 80,000 BTU on the 72"
- Larger broiling surface (30" x 14" = 416 sq.in. broiling area)
- Counter balanced rack system
- Easy glide rack mechanism
- Heavy-duty, chrome plated handle
- Removable broiling racks
- Smooth design - no exposed fasteners
- No charge flue riser mount kit with factory interpiping when purchased with a range

## Compact Radiant Salamanders

Configuration	Model Number	Weight	Dimension WxHxD
<b>PLATINUM SERIES</b>			
32" Radiant Salamander 40,000 BTU -Riser Mount	P32-RAD	155 (70)	32"x21.5"x15.5"
36" Radiant Salamander 40,000 BTU - Riser Mount	P36-RAD	170 (77)	36"x21.5"x15.5"
48" Radiant Salamander 60,000 BTU - Riser Mount	P48-RAD	210 (95)	48"x21.5"x15.5"

## Compact Infrared Salamanders

Configuration	Model Number	Weight	Dimension WxHxD
<b>PLATINUM SERIES</b>			
32" Compact Infrared Broiler 40,000 BTU - Riser Mount	P32-NFR	155 (70)	32"x21.5"x15.5"
36" Compact Infrared Broiler 40,000 BTU - Riser Mount	P36-NFR	170 (77)	36"x21.5"x15.5"
48" Compact Infrared Broiler 60,000 BTU - Riser Mount	P48-NFR	210 (95)	48"x21.5"x15.5"

# Cheesemelter

## What's a Cheesemelter?

An overfired broiler designed to broil plated food on a fixed rack.



P36-CM

## Standard Features

- Cheesemelters available in 24", 32", 36", 48", 60" and 72"
- Dual valve control for left and right operation
- 20,000 BTU on the 24", 40,000 BTU on the 32" and 36", 60,000 BTU on the 48" and 60", and 80,000 BTU on the 72"
- Larger broiling surface (30" x 14" = 416 sq.in. broiling area)
- No exposed fasteners
- External gas regulator
- Stainless steel interior
- Pass through units available at no extra charge
- No charge flue riser mount kit with factory interpiping when purchased with a range

## Cheesemelter

Configuration	Model Number	Weight	Dimension WxHxD
<b>PLATINUM SERIES</b>			
24" Infrared Cheesemelter 20,000 BTU - Riser Mount	P24-CM	90 (41)	24"x21.5"x15.5"
32" Infrared Cheesemelter 40,000 BTU - Riser Mount	P32-CM	120 (54)	32"x21.5"x15.5"
36" Infrared Cheesemelter 40,000 BTU - Riser Mount	P36-CM	135 (61)	36"x21.5"x15.5"
48" Infrared Cheesemelter 60,000 BTU - Riser Mount	P48-CM	175 (79)	48"x21.5"x15.5"
60" Infrared Cheesemelter 60,000 BTU - Riser Mount	P60-CM	220 (100)	60"x21.5"x15.5"
72" Infrared Cheesemelter 80,000 BTU - Riser Mount	P72-CM	265 (120)	72"x21.5"x15.5"

## RAD/NFR/CHEESEMELTER Options and Accessories

Options and Accessories
Slope enclosure for 32" units (required in some states)
Slope enclosure for 36" units (required in some states)
Slope enclosure for 48" units (required in some states)
Slope enclosure for 60" units (required in some states)
Wall mounting brackets in lieu of uprights
Counter mount kit with legs
Flue mount kit
Extra chrome plated racks (24" units)
Extra chrome plated racks (32" units)
Extra chrome plated racks (36" units)
Extra chrome plated racks (48" units)
Extra chrome plated racks (60" units)
Extra chrome plated racks (72" units)

\* Broilers and Cheesemelter can be mounted on various sizes of flue risers.





# Restaurant Ranges

---

For the ultimate in configurability, durability and performance; nothing compares to the unbeatable value of a Southbend restaurant grade range

The Electric Range is available in several configurations to accommodate any kitchen. Standard , Convection, and TruVection base are available.

The Ultimate Range is 100% made in the USA! Available in 5 sizes and over **2,000** configurations, the Ultimate Range is manufactured with an unprecedented fully stainless steel burner box. Higher BTU's and High Efficiency Snap Action Thermostat make it easy to handle any specific cooking and baking need.

The S-Series restaurant range offers a quality, versatile range for commercial foodservice applications. 24", 36", 48", and 60" widths and a number of top configurations are available. Configurations include combinations of open burners, griddles and hot tops.

# Heavy Duty Electric Range



SE36A-TTT  
w/ optional casters

Available with a  
**TruVection Base!**



SE36T-BBB  
w/ optional casters

## Standard Features

- Stainless steel front, sides and top
- Hatchable to pass through 26" opening
- Includes 6" NSF listed legs
- Front serviceable
- 36" cooking height

## Additional features of models with convection oven:

- Includes three oven racks
- Stainless steel oven and door liner
- Vented, air cooled motor

## Additional features of models with standard oven:

- Includes one oven rack
- Aluminized steel oven liner
- Stainless steel door liners

## Electric Range

Configuration		Oven Base	Model Number	Weight	Dimension (WxHxD)
(3) 12"x24" hotplates (5.3kW/ea)		Standard Convection TruVection	SE36D-HHH* SE36A-HHH* SE36T-HHH	700 (318)	36"x38.25"x38.5" 36"x38.25"x38.5" 36"x40.4"x38.5"
(2) 12"x24" hotplates (5.3kW/ea) & (2) round hotplates (2.6kW/ea)		Standard Convection TruVection	SE36D-HHB* SE36A-HHB* SE36T-HHB	660 (299)	36"x38.25"x38.5" 36"x38.25"x38.5" 36"x40.4"x38.5"
(1) 36"x24" griddle (16.5kW)		Standard Convection TruVection	SE36D-TTT* SE36A-TTT* SE36T-TTT	700 (318)	36"x38.25"x38.5" 36"x38.25"x38.5" 36"x40.4"x38.5"
(6) round hotplates (2.6kW/ea)		Standard Convection TruVection	SE36D-BBB* SE36A-BBB* SE36T-BBB	650 (295)	36"x38.25"x38.5" 36"x38.25"x38.5" 36"x40.4"x38.5"
(1) 24"x24" griddle (10.6kW) & (2) round hotplates (2.6kW/ea)(specify left or right)		Standard Convection TruVection	SE36D-TTB* SE36A-TTB* SE36T-TTB	660 (299)	36"x38.25"x38.5" 36"x38.25"x38.5" 36"x40.4"x38.5"
(1) 24"x24" griddle (10.6kW) & (1) 12"x24" hotplate (5.3kW)		Standard Convection TruVection	SE36D-TTH* SE36A-TTH* SE36T-TTH	660 (299)	36"x38.25"x38.5" 36"x38.25"x38.5" 36"x40.4"x38.5"

Available 480V 3 Phase

\*Available in 3 Phase only (not available in single phase)

## Options and Accessories

Accessories			
Part Number	Description	Weight (lbs)	Available for use with:
ACCS06K	Casters, set of four, 2 swivel (with locks)	18	All SE models
ACRK36K	Deck oven rack, slide-out	21	All SE36D models
ACBK36H	Outer back, stainless steel	5	All SE models
Marine Kits			
Marine kits are designed to provide shipboard stability to SE models. Include bolt-down legs, door latch, grab rails, sea racks (kits A and B only), grease trays with latches and stainless steel backs. Field assembly required.			
MH36KITA	Marine Kit, tops 1,2 and 4	20	SE36-HHH, HHB, BBB
MH36KITB	Marine Kit tops 5 & 6	20	SE36-TTB, TTH
MH36KITC	Marine Kit, top 3	20	SE36-TTT
Voltage Increase			
480v increase			



# The Ultimate Restaurant Range

## 400 Series



4361D  
w/ optional  
cheesemelter &  
casters

### Standard Features

- Five sizes and over **2,000** of combinations including our 5 burner configuration
- Choice of:
  - 33K BTU **PATENTED** lifetime non-clog burners
  - 33K BTU Star/sauté burners
  - 40K BTU 18" PyroMax burners
- Front manual gas shut off valve
- Standard battery spark ignition for oven cavities
- Metal knobs
- 6" stainless legs standard
- Choice of electric oven base with gas top (hybrid)
- Factory installed regulator
- Standard 22.5" flue riser with heavy-duty high shelf
- Flue riser mounted salamander or cheesemelter
- 27" deep cooking surface

For broiler range mount (cheesemelter, radiant, infrared) see page 26-27.  
Optional battery spark ignition (charbroiler, griddle, open top, and hot tops).  
Optional 5" or 10" flue riser.

### CHOOSE YOUR BURNER





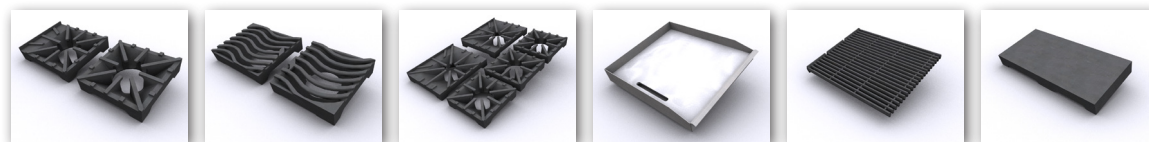











### CHOOSE YOUR TOP



## Competitive Information

Standard Features:	Southbend Ultimate 400	Garland G Series	Bakers Pride Restaurant Series	US Range U Series	Wolf Challenger	Vulcan Endurance
Stainless steel front, sides and legs	Yes	Yes	Yes	Yes	Yes	Yes
Flue height options - no charge	Yes	Yes	No	Yes	No	No
Rear grate dimensions	12"x15"	12"x13.5"	12"x12"	12"x13.5"	12"x14.5"	12"x14.5"
15" x 18" stock pot grate	Yes	No	No	No	No	No
Five burner range configuration available	Yes	No	No	No	No	No
Non-clog or Star/Saute burner option - no charge	Yes	No	No	No	No	No
Lifetime warranty for non-clog burner	Yes	No	No	No	No	No
Open burner BTUs	33K	33K	40K	32K	30K	30K
Battery spark ignition - oven standard	Yes	No	No	No	No	No
Manual gas shut off to entire unit - standard	Yes	No	No	No	No	No
High efficiency snap action oven thermostat	Yes	Yes	No	No	No	No
Full porcelain oven interior	Yes	Yes	No	No	No	No
Standard oven BTUs	45K	38K	40K	38K	35K	35K
On/Off convection oven switch	Yes	No	No	No	No	No
Oven temp range	175°F-550°F	low-500°F	150°F-500°F	low-500°F	250°F-500°F	250°F-500°F
Rack positions	2	3	5	3	4	4
Racks included	1	1	1	1	2	2
Optional hybrid electric oven base	Yes	No	No	No	No	No











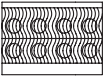
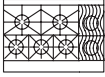
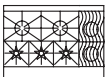
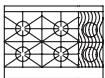
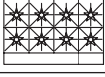

Top Configuration		Base	Model Number	Weight	Dimension (WxHxD)
24" Range with 4 - 33K BTU Non-clog Burners with Standard Grates		Cabinet Space Saver	4241C 4241E	475(216)	24.25"x59.5"x34"
24" Range with 4 - 33K BTU Non-clog Burners with Wavy Grates		Cabinet Space Saver	4242C 4242E	474 (216)	24.38"x59.5"x34"
24" Range with 4 - 33K BTU Non-clog Burners with Star Grates		Cabinet Space Saver	4243C 4243E	475 (216)	24.38"x59.5"x34"
24" Range with 4 - 33K BTU Non-clog Burners with Split Grates		Cabinet Space Saver	4244C 4244E	475 (216)	24.38"x59.5"x34"
36" Range with 6 - 33K BTU Non-clog Burners with Standard Grates		Convection Cabinet Standard Hybrid Convection Hybrid Standard	4361A 4361C 4361D H4361A H4361D	660(300)	36.5"x59.5"x42.13" 36.5"x59.5"x34" 36.5"x59.5"x34" 36.5"x59.5"x42.13" 36.5"x59.5"x34"
36" Range with 6 - 27K BTU Non-clog Burners with Wavy Grates		Convection Cabinet Standard Hybrid Convection Hybrid Standard	4362A 4362C 4362D H4362A H4362D	660(300)	36.5"x59.5"x42.13" 36.5"x59.5"x34" 36.5"x59.5"x34" 36.5"x59.5"x42.13" 36.5"x59.5"x34"
36" Range with 6 - 33K BTU Star/Sauté Burners with Standard Grates		Convection Cabinet Standard Hybrid Convection Hybrid Standard	4363A 4363C 4363D H4363A H4363D	660(300)	36.5"x59.5"x42.13" 36.5"x59.5"x34" 36.5"x59.5"x34" 36.5"x59.5"x42.13" 36.5"x59.5"x34"
36" Range with 3 - 33K BTU Non-clog Burners Rear and 3 - 33K BTU Star/Sauté Burners Front		Convection Cabinet Standard Hybrid Convection Hybrid Standard	4364A 4364C 4364D H4364A H4364D	660(300)	36.5"x59.5"x42.13" 36.5"x59.5"x34" 36.5"x59.5"x34" 36.5"x59.5"x42.13" 36.5"x59.5"x34"
36" Range with 2 - 40K BTU Pyromax Burners Rear and 3 - 33K BTU Non-clog Burners Front		Convection Cabinet Standard Hybrid Convection Hybrid Standard	4365A 4365C 4365D H4365A H4365D	660(300)	36.5"x59.5"x42.13" 36.5"x59.5"x34" 36.5"x59.5"x34" 36.5"x59.5"x42.13" 36.5"x59.5"x34"
36" Range with 2 - 40K BTU Pyromax Burners Rear and 3 - 33K BTU Star/Sauté Burners Front		Convection Cabinet Standard Hybrid Convection Hybrid Standard	4366A 4366C 4366D H4366A H4366D	660(300)	36.5"x59.5"x42.13" 36.5"x59.5"x34" 36.5"x59.5"x34" 36.5"x59.5"x42.13" 36.5"x59.5"x34"
36" Range with 4 - 40K BTU Pyromax Burners		Convection Cabinet Standard Hybrid Convection Hybrid Standard	4367A 4367C 4367D H4367A H4367D	660(300)	36.5"x59.5"x42.13" 36.5"x59.5"x34" 36.5"x59.5"x34" 36.5"x59.5"x42.13" 36.5"x59.5"x34"
48" Range with 8 - 33K BTU Non-clog Burners		Convection/Cabinet Standard/Cabinet Dual Space Saver	4481AC 4481DC 4481EE	735(334)	48.625"x59.5"x34" 48.625"x59.5"x34" 48.625"x59.5"x42.13"
48" Range with 3 - 33K BTU Non-clog Burners Front and 2 - 40K BTU Pyromax Burners Rear and 2 - 33K BTU Non-clog Burners Side		Convection/Cabinet Standard/Cabinet Dual Space Saver	4481AC-5L 4481AC-5R 4481DC-5* 4481EE-5*	735(334)	48.625"x59.5"x34" 48.625"x59.5"x34" 48.625"x59.5"x42.13"
48" Range with 3 - 33K BTU Star/Sauté Burners Front and 2 - 40K BTU Pyromax Burners Rear and 2 - 33K BTU Non-clog Burners Side		Convection/Cabinet Standard/Cabinet Dual Space Saver	4481AC-6* 4481DC-6* 4481EE-6*	735(334)	48.625"x59.5"x34" 48.625"x59.5"x34" 48.625"x59.5"x42.13"
48" Range with 4 - 40K BTU Pyromax Burners and 2 - 33K BTU Non-clog Burners Side		Convection/Cabinet Standard/Cabinet Dual Space Saver	4481AC-7* 4481DC-7* 4481EE-7*	735(334)	48.625"x59.5"x34" 48.625"x59.5"x34" 48.625"x59.5"x42.13"

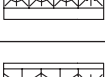
\*Available on left or right. Please add "L" for left or "R" for right to the model number.  
Notes: "D" = standard oven. "A" = convection oven (standard on left). "E" = space-saver oven is available in standard only. "C" = Cabinet in lieu of oven. Cabinets standard with no doors, optional doors available at no charge. Standard oven includes 1 rack, convection oven includes 3.

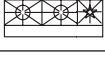

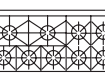
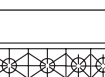
The Ultimate Series - Open Tops

Top Configuration		Base	Model Number	Weight	Dimension (WxHxD)
48" Range with 8 - 33K BTU Non-clog Burners with Wavy Grates		Convection/Cabinet Standard/Cabinet Dual Space Saver	4482AC 4482DC 4482EE	735 (334)	48.63"x59.5"x42.13" 48.63"x59.5"x34" 48.63"x59.5"x34"
48" Range with 3 - 33K BTU Non-clog Burners Front and 2 - 40K BTU Pyromax Burners Rear and 2 - 33K BTU Non-clog Burners Side with Wavy Grates		Convection/Cabinet Standard/Cabinet Dual Space Saver	4482AC-5* 4482DC-5* 4482EE-5*	735 (334)	48.63"x59.5"x42.13" 48.63"x59.5"x34" 48.63"x59.5"x34"
48" Range with 3-33K BTU Star/Saute Burners Front and 2-40K BTU Pyromax Burners Rear and 2-33K Non-Clog Burners Side with Wavy Grates		Convection/Cabinet Standard/Cabinet Dual Space Saver	4482AC-6* 4482DC-6* 4482EE-6*	735 (334)	48.63"x59.5"x42.13" 48.63"x59.5"x34" 48.63"x59.5"x34"
48" Range with 4-40K BTU Pyromax Burners and 2-33K Non-Clog Burners with Wavy Grates		Convection/Cabinet Standard/Cabinet Dual Space Saver	4482AC-7* 4482DC-7* 4482EE-7*	735 (334)	48.63"x59.5"x42.13" 48.63"x59.5"x34" 48.63"x59.5"x34"
48" Range with 8 - 33K BTU Star/Sauté Burners		Convection/Cabinet Standard/Cabinet Dual Space Saver	4483AC 4483DC 4483EE	735 (334)	48.63"x59.5"x42.13" 48.63"x59.5"x34" 48.63"x59.5"x34"
48" Range with 3-33K BTU Non-Clog Burners Front and 2-40K BTU Pyromax Burners Rear and 2-33K BTU Star/Saute Burners Side		Convection/Cabinet Standard/Cabinet Dual Space Saver	4483AC-5* 4483DC-5* 4483EE-5*	735 (334)	48.63"x59.5"x42.13" 48.63"x59.5"x34" 48.63"x59.5"x34"
48" Range with 3-33K BTU Star/saute Burners Front and 2-40K BTU Pyromax Burners Rear and 2-33K BTU Star/Saute Burners Side		Convection/Cabinet Standard/Cabinet Dual Space Saver	4483AC-6* 4483DC-6* 4483EE-6*	735 (334)	48.63"x59.5"x42.13" 48.63"x59.5"x34" 48.63"x59.5"x34"
48" Range with 4-40K BTU Pyromax Burners and 2-33K BTU Star/Saute Burners Side		Convection/Cabinet Standard/Cabinet Dual Space Saver	4483AC-7* 4483DC-7* 4483EE-7*	735 (334)	48.63"x59.5"x42.13" 48.63"x59.5"x34" 48.63"x59.5"x34"
48" Range with 4-33K BTU Star/Saute Burners Front and 4-33K BTU Non-Clog Burners Rear		Convection/Cabinet Standard/Cabinet Dual Space Saver	4484AC 4484DC 4484EE	735 (334)	48.63"x59.5"x42.13" 48.63"x59.5"x34" 48.63"x59.5"x34"
48" Range with 3-33K BTU Non-Clog Burners Front and 2-40K BTU Pyromax Burners Rear and 1-33K BTU Star/Saute Burner and 1-33K BTU Non-Clog Burner side		Convection/Cabinet Standard/Cabinet Dual Space Saver	4484AC-5* 4484DC-5* 4484EE-5*	735 (334)	48.63"x59.5"x42.13" 48.63"x59.5"x34" 48.63"x59.5"x34"
48" Range with 3-33K BTU Non-Clog Burners Front and 2-40K BTU Pyromax Rear and 1-33K BTU Star/Saute Burner and 1-33K BTU Non-Clog Burner Side		Convection/Cabinet Standard/Cabinet Dual Space Saver	4484AC-6* 4484DC-6* 4484EE-6*	735 (334)	48.63"x59.5"x42.13" 48.63"x59.5"x34" 48.63"x59.5"x34"
48" Range with 4-40K BTU Pyromax Burners and 1-33K BTU Star/Saute Burner and 1-33K BTU Non-Clog Burner		Convection/Cabinet Standard/Cabinet Dual Space Saver	4484AC-7* 4484DC-7* 4484EE-7*	735 (334)	48.63"x59.5"x42.13" 48.63"x59.5"x34" 48.63"x59.5"x34"
60" Range with 10 - 33K BTU Non-clog Burners with Standard Grates		Convection/Convection Convection/Cabinet Convection/Standard Cabinet/Cabinet Standard/Cabinet Standard/Standard	4601AA 4601AC 4601AD 4601CC 4601DC 4601DD	1075(488)	60.75"x59.5"x42.13" 60.75"x59.5"x42.13" 60.75"x59.5"x42.13" 60.75"x59.5"x34" 60.75"x59.5"x34" 60.75"x59.5"x34"
60" Range with 4 - 33K BTU Non-clog Burners with Standard Grates and 5 Burner Configuration to include 2 - 40K Pyromax Rear and 3 - 33K Non-clog Burners Front		Convection/Convection Convection/Cabinet Convection/Standard Cabinet/Cabinet Standard/Cabinet Standard/Standard	4601AA-5* 4601AC-5* 4601AD-5* 4601CC-5* 4601DC-5* 4601DD-5*	1075(488)	60.75"x59.5"x34" 60.75"x59.5"x42.13" 60.75"x59.5"x42.13" 60.75"x59.5"x34" 60.75"x59.5"x42.13" 60.75"x59.5"x34"
60" Range with 4 - 33K BTU Non-clog Burners with Standard Grates and 5 Burner Configuration to include 2 - 40K Pyromax Rear and 3 -33K Star/Sauté Burners Front		Convection/Convection Convection/Cabinet Convection/Standard Cabinet/Cabinet Standard/Cabinet Standard/Standard	4601AA-6* 4601AC-6* 4601AD-6* 4601CC-6* 4601DC-6* 4601DD-6*	1075(488)	60.75"x59.5"x42.13" 60.75"x59.5"x42.13" 60.75"x59.5"x42.13" 60.75"x59.5"x34" 60.75"x59.5"x42.13" 60.75"x59.5"x34"
60" Range with 4 - 33K BTU Non-clog Burners with Standard Grates and 4 - 40K Pyromax Burners		Convection/Convection Convection/Cabinet Convection/Standard Cabinet/Cabinet Standard/Cabinet Standard/Standard	4601AA-7* 4601AC-7* 4601AD-7* 4601CC-7* 4601DC-7* 4601DD-7*	1075(488)	60.75"x59.5"x42.13" 60.75"x59.5"x42.13" 60.75"x59.5"x42.13" 60.75"x59.5"x34" 60.75"x59.5"x34" 60.75"x59.5"x34"

\*Available on left or right. Please add "L" for left or "R" for right to the model number.

Notes: "D" = standard oven. "A" = convection oven (standard on left). "E" = space-saver oven is available in standard only. "C" = Cabinet in lieu of oven. Cabinets standard with no doors, optional doors available at no charge. Standard oven includes 1 rack, convection oven includes 3.

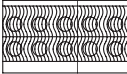
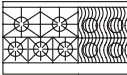
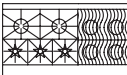
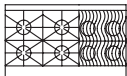
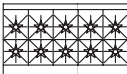
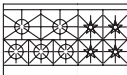
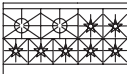
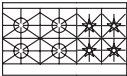
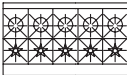
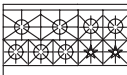
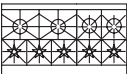
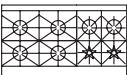

Top Configuration		Base	Model Number	Weight	Dimension (WxHxD)
60" Range with 10 - 33K BTU Non-clog Burners with Wavy Grates		Convection/Convection Convection/Cabinet Convection/Standard Cabinet/Cabinet Standard/Cabinet Standard/Standard	4602AA 4602AC 4602AD 4602CC 4602DC 4602DD	1075(488)	60.75"x59.5"x42.13" 60.75"x59.5"x42.13" 60.75"x59.5"x42.13" 60.75"x59.5"x34" 60.75"x59.5"x34" 60.75"x59.5"x34"
60" Range with 4 - 33K BTU Non-clog Burners with Wavy Grates and 5 Burner Configuration to include 2 - 40K Pyromax Rear and 3 - 33K Non-clog Burners Front		Convection/Convection Convection/Cabinet Convection/Standard Cabinet/Cabinet Standard/Cabinet Standard/Standard	4602AA-5* 4602AC-5* 4602AD-5* 4602CC-5* 4602DC-5* 4602DD-5*	1075(488)	60.75"x59.5"x42.13" 60.75"x59.5"x42.13" 60.75"x59.5"x42.13" 60.75"x59.5"x34" 60.75"x59.5"x34" 60.75"x59.5"x34"
60" Range with 4 - 33K BTU Non-clog Burners with Wavy Grates and 5 Burner Configuration to include 2 - 40K Pyromax Rear and 3-33K Star/Sauté Burners Front		Convection/Convection Convection/Cabinet Convection/Standard Cabinet/Cabinet Standard/Cabinet Standard/Standard	4602AA-6* 4602AC-6* 4602AD-6* 4602CC-6* 4602DC-6* 4602DD-6*	1075(488)	60.75"x59.5"x42.13" 60.75"x59.5"x42.13" 60.75"x59.5"x42.13" 60.75"x59.5"x34" 60.75"x59.5"x34" 60.75"x59.5"x34"
60" Range with 4 - 33K BTU Non-clog Burners with Wavy Grates and 4- 40K Pyromax Burners		Convection/Convection Convection/Cabinet Convection/Standard Cabinet/Cabinet Standard/Cabinet Standard/Standard	4602AA-7* 4602AC-7* 4602AD-7* 4602CC-7* 4602DC-7* 4602DD-7*	1075(488)	60.75"x59.5"x42.13" 60.75"x59.5"x42.13" 60.75"x59.5"x42.13" 60.75"x59.5"x34" 60.75"x59.5"x34" 60.75"x59.5"x34"
60" Range with 10-33K BTU Star/Saute Burners with Standard Grates		Convection/Convection Convection/Cabinet Convection/Standard Cabinet/Cabinet Standard/Cabinet Standard/Standard	4603AA 4603AC 4603AD 4603CC 4603DC 4603DD	1075(488)	60.75"x59.5"x42.13" 60.75"x59.5"x42.13" 60.75"x59.5"x42.13" 60.75"x59.5"x34" 60.75"x59.5"x34" 60.75"x59.5"x34"
60" Range with 3-33K BTU Non-Clog Burners Front 2-40K BTU Pyromax Burners rear 4-33K BTU Star/Saute Burners Side		Convection/Convection Convection/Cabinet Convection/Standard Cabinet/Cabinet Standard/Cabinet Standard/Standard	4603AA-5* 4603AC-5* 4603AD-5* 4603CC-5* 4603DC-5* 4603DD-5*	1075(488)	60.75"x59.5"x42.13" 60.75"x59.5"x42.13" 60.75"x59.5"x42.13" 60.75"x59.5"x34" 60.75"x59.5"x34" 60.75"x59.5"x34"
60" Range with 3-33K BTU Star/Saute Burners Front 2-40K BTU Pyromax Burners rear 4-33K BTU Star/Saute Burners Side		Convection/Convection Convection/Cabinet Convection/Standard Cabinet/Cabinet Standard/Cabinet Standard/Standard	4603AA-6* 4603AC-6* 4603AD-6* 4603CC-6* 4603DC-6* 4603DD-6*	1075(488)	60.75"x59.5"x42.13" 60.75"x59.5"x42.13" 60.75"x59.5"x42.13" 60.75"x59.5"x34" 60.75"x59.5"x34" 60.75"x59.5"x34"
60" Range with 4-33K BTU Star/Saute Burners 4-40K BTU Pyromax Burners		Convection/Convection Convection/Cabinet Convection/Standard Cabinet/Cabinet Standard/Cabinet Standard/Standard	4603AA-7* 4603AC-7* 4603AD-7* 4603CC-7* 4603DC-7* 4603DD-7*	1075(488)	60.75"x59.5"x42.13" 60.75"x59.5"x42.13" 60.75"x59.5"x42.13" 60.75"x59.5"x34" 60.75"x59.5"x34" 60.75"x59.5"x34"
60" Range with 5-33K BTU Star/Saute Burners Front 5-33K BTU Non-Clog Burners in Rear with Standard Grates		Convection/Convection Convection/Cabinet Convection/Standard Cabinet/Cabinet Standard/Cabinet Standard/Standard	4604AA 4604AC 4604AD 4604CC 4604DC 4604DD	1075(488)	60.75"x59.5"x42.13" 60.75"x59.5"x42.13" 60.75"x59.5"x42.13" 60.75"x59.5"x34" 60.75"x59.5"x34" 60.75"x59.5"x34"
60" Range with 4 - 33K BTU Non-clog Burners with Split Grates and 5 Burner Configuration to include 2 - 40K Pyromax Rear and 3 - 33K Non-clog Burners Front		Convection/Convection Convection/Cabinet Convection/Standard Cabinet/Cabinet Standard/Cabinet Standard/Standard	4604AA-5* 4604AC-5* 4604AD-5* 4604CC-5* 4604DC-5* 4604DD-5*	1075(488)	60.75"x59.5"x42.13" 60.75"x59.5"x42.13" 60.75"x59.5"x42.13" 60.75"x59.5"x34" 60.75"x59.5"x34" 60.75"x59.5"x34"
60" Range with 4 - 33K BTU Non-clog Burners with Split Grates and 5 Burner Configuration to include 2 - 40K Pyromax Rear and 3 - 33K Star/Sauté Burners Front		Convection/Convection Convection/Cabinet Convection/Standard Cabinet/Cabinet Standard/Cabinet Standard/Standard	4604AA-6* 4604AC-6* 4604AD-6* 4604CC-6* 4604DC-6* 4604DD-6*	1075(488)	60.75"x59.5"x42.13" 60.75"x59.5"x42.13" 60.75"x59.5"x42.13" 60.75"x59.5"x34" 60.75"x59.5"x34" 60.75"x59.5"x34"
60" Range with 4 - 33K BTU Non-clog Burners with Split Grates and 4- 40K Pyromax Burners		Convection/Convection Convection/Cabinet Convection/Standard Cabinet/Cabinet Standard/Cabinet Standard/Standard	4604AA-7* 4604AC-7* 4604AD-7* 4604CC-7* 4604DC-7* 4604DD-7*	1075(488)	60.75"x59.5"x42.13" 60.75"x59.5"x42.13" 60.75"x59.5"x42.13" 60.75"x59.5"x34" 60.75"x59.5"x34" 60.75"x59.5"x34"

\*Available on left or right. Please add "L" for left or "R" for right to the model number.

Notes: "D" = standard oven. "A" = convection oven (standard on left). "E" = space-saver oven is available in standard only. "C" = Cabinet in lieu of oven. Cabinets standard with no doors, optional doors available at no charge. Standard oven includes 1 rack, convection oven includes 3.



## The Ultimate Series - Griddle Tops

Top Configuration		Base	Model Number	Weight	Dimension (WxHxD)
36" Range with 36" Griddle		Convection Cabinet Standard Hybrid Convection Hybrid Standard	436A-3G/T* 436C-3G/T* 436D-3G/T* H436A-3G/T* H436D-3G/T*	660(300)	36.5"x59.5"x42.13" 36.5"x59.5"x34" 36.5"x59.5"x34" 36.5"x59.5"x42.13" 36.5"x59.5"x34"
36" Range with 4 - 33K BTU Non-clog Burners with Standard Grates and 12" Griddle (Left or Right)		Convection Cabinet Standard Hybrid Convection Hybrid Standard	4361A-1G 4361C-1G 4361D-1G H4361A-1G H4361D-1G	660(300)	36.5"x59.5"x42.13" 36.5"x59.5"x34" 36.5"x59.5"x34" 36.5"x59.5"x42.13" 36.5"x59.5"x34"
36" Range with 2 - 33K BTU Non-clog Burners with Standard Grates and 24" Griddle (Left or Right)		Convection Cabinet Standard Hybrid Convection Hybrid Standard	4361A-2G/T* 4361C-2G/T* 4361D-2G/T* H4361A-2G/T* H4361D-2G/T*	660(300)	36.5"x59.5"x42.13" 36.5"x59.5"x34" 36.5"x59.5"x34" 36.5"x59.5"x42.13" 36.5"x59.5"x34"
36" Range with 4 - 33K BTU Non-clog Burners with Wavy Grates and 12" Griddle (Left or Right)		Convection Cabinet Standard	4362A-1G* 4362C-1G* 4362D-1G*	660(300)	36.5"x59.5"x42.13" 36.5"x59.5"x34" 36.5"x59.5"x34"
36" Range with 2-33K BTU Non-clog Burners with Wavy Grates and 24" Griddle		Convection Cabinet Standard	4362A-2G/T* 4362C-2G/T* 4362D-2G/T*	660(300)	36.5"x59.5"x42.13" 36.5"x59.5"x34" 36.5"x59.5"x34"
36" Range with 4-33K BTU Star/Saute Burners with Standard Grates		Convection Cabinet Standard	4363A-1G 4363C-1G 4363D-1G	660(300)	36.5"x59.5"x42.13" 36.5"x59.5"x34" 36.5"x59.5"x34"
"36" Range with 2-33K BTU Star/Saute Burners with Standard Grates" and 24" Griddle		Convection Cabinet Standard	4363A-2G/T* 4363C-2G/T* 4363D-2G/T*	660(300)	36.5"x59.5"x42.13" 36.5"x59.5"x34" 36.5"x59.5"x34"
36" Range with 2-33K BTU Star/Saute Burners 2-33K BTU Non-Clog Burners with Standard Grates" and 12" Griddle		Convection Cabinet Standard	4364A-1G 4364C-1G 4364D-1G	660(300)	36.5"x59.5"x42.13" 36.5"x59.5"x34" 36.5"x59.5"x34"
36" Range with 1-33K BTU Star/Saute Burners 1-33K BTU Non-Clog Burners and 24" Griddle		Convection Cabinet Standard	4364A-2G/T* 4364C-2G/T* 4364D-2G/T*	660(300)	36.5"x59.5"x42.13" 36.5"x59.5"x34" 36.5"x59.5"x34"
48" Range with 4 - 33K BTU Non-clog Burners with 24" Griddle (Left or Right)		Convection/Cabinet Standard/Cabinet Dual Space Saver	4481AC-2G/T* 4481DC-2G/T* 4481EE-2G/T*	735(334)	48.625"x59.5"x42.13" 48.625"x59.5"x34" 48.625"x59.5"x34"
48" Range with 2 - 33K BTU Non-clog Burners with 36" Griddle (Left or Right)		Convection/Cabinet Standard/Cabinet Dual Space Saver	4481AC-3G/T* 4481DC-3G/T* 4481EE-3G/T*	735(334)	48.625"x59.5"x42.13" 48.625"x59.5"x34" 48.625"x59.5"x34"
48" Range with 48" Griddle		Convection/Cabinet Standard/Cabinet Dual Space Saver	448AC-4G/T* 448DC-4G/T* 448EE-4G/T*	735(334)	48.625"x59.5"x42.13" 48.625"x59.5"x34" 48.625"x59.5"x34"
48" Range with 4-33K BTU Non-Clog Burners with Wavy Grates and 24" Griddle (Left or Right)		Convection/Cabinet Standard/Cabinet Dual Space Saver	4482AC-2G/T* 4482DC-2G/T* 4482EE-2G/T*	735(334)	48.625"x59.5"x42.13" 48.625"x59.5"x34" 48.625"x59.5"x34"
48" Range with 2-33K BTU Non-Clog Burners with Wavy Grates and 36" Griddle (Left or Right)		Convection/Cabinet Standard/Cabinet Dual Space Saver	4482AC-3G/T* 4482DC-3G/T* 4482EE-3G/T*	735(334)	48.625"x59.5"x42.13" 48.625"x59.5"x34" 48.625"x59.5"x34"
48" Range with 4-33 K BTU Star/Saute Burners with Standard Grates and 24" Griddle (Left or Right)		Convection/Cabinet Standard/Cabinet Dual Space Saver	4483AC-2G/T* 4483DC-2G/T* 4483EE-2G/T*	735(334)	48.625"x59.5"x42.13" 48.625"x59.5"x34" 48.625"x59.5"x34"
48" Range with 2-33 K BTU Star/Saute Burners with Standard Grates and 36" Griddle (Left or Right)		Convection/Cabinet Standard/Cabinet Dual Space Saver	4483AC-3G/T* 4483DC-3G/T* 4483EE-3G/T*	735(334)	48.625"x59.5"x42.13" 48.625"x59.5"x34" 48.625"x59.5"x34"

\*Available on left or right. Please add "L" for left or "R" for right to the model number.

\*\*Raised broiler/griddle available on right only.

Notes: "D" = standard oven. "A" = convection oven (standard on left). "E" = space-saver oven is available in standard only.

"C" = Cabinet in lieu of oven. Cabinets standard with no doors, optional doors available at no charge.

"G" = manual griddle. "T" = thermostatic griddle

Standard oven includes 1 rack, convection oven includes 3.



Top Configuration		Base	Model Number	Weight	Dimension (WxHxD)
48" Range with 2-33K BTU Star/Saute Burners and 2-33K BTU Non-Clog Burners Rear with Standard Grates and 24" Griddle (Left or Right)		Convection/Cabinet Standard/Cabinet Dual Space Saver	4484AC-2G/T* 4484DC-2G/T* 4484EE-2G/T*	735(334)	48.625"x59.5"x42.13" 48.625"x59.5"x34" 48.625"x59.5"x34"
48" Range with 1-33K BTU Star/Saute Burners & 1-33K BTU Non-Clog Burners in Rear with Standard Grates and 36" Griddle (Left or Right)		Convection/Cabinet Standard/Cabinet Dual Space Saver	4484AC-3G/T* 4484DC-3G/T* 4484EE-3G/T*	735(334)	48.625"x59.5"x42.13" 48.625"x59.5"x34" 48.625"x59.5"x34"
60" Range with 6 - 33K BTU Non-clog Burners with Standard Grates and 24" Griddle (Left or Right)		Convection/Convection Convection/Cabinet Convection/Standard Cabinet/Cabinet Standard/Cabinet Standard/Standard	4601AA-2G/T* 4601AC-2G/T* 4601AD-2G/T* 4601CC-2G/T* 4601DC-2G/T* 4601DD-2G/T*	1075(488)	60.75"x59.5"x42.13" 60.75"x59.5"x42.13" 60.75"x59.5"x42.13" 60.75"x59.5"x34" 60.75"x59.5"x34" 60.75"x59.5"x34"
60" Range with 4 - 33K BTU Non-clog Burners with Standard Grates and 36" Griddle (Left or Right)		Convection/Convection Convection/Cabinet Convection/Standard Cabinet/Cabinet Standard/Cabinet Standard/Standard	4601AA-3G/T* 4601AC-3G/T* 4601AD-3G/T* 4601CC-3G/T* 4601DC-3G/T* 4601DD-3G/T*	1075(488)	60.75"x59.5"x42.13" 60.75"x59.5"x42.13" 60.75"x59.5"x42.13" 60.75"x59.5"x34" 60.75"x59.5"x34" 60.75"x59.5"x34"
60" Range with 2 - 33K BTU Non-clog Burners with Standard Grates and 48" Griddle (Left or Right)		Convection/Convection Convection/Cabinet Convection/Standard Cabinet/Cabinet Standard/Cabinet Standard/Standard	4601AA-4G/T* 4601AC-4G/T* 4601AD-4G/T* 4601CC-4G/T* 4601DC-4G/T* 4601DD-4G/T*	1075(488)	60.75"x59.5"x42.13" 60.75"x59.5"x42.13" 60.75"x59.5"x42.13" 60.75"x59.5"x34" 60.75"x59.5"x34" 60.75"x59.5"x34"
60" Range with 6 - 33K BTU Non-clog Burners with Standard Grates and 24" Raised Griddle/Broiler (right only)		Convection/Convection Convection/Cabinet Convection/Standard Cabinet/Cabinet Standard/Cabinet Standard/Standard	4601AA-2RR** 4601AC-2RR** 4601AD-2RR** 4601CC-2RR** 4601DC-2RR** 4601DD-2RR**	1075(488)	60.75"x59.5"x42.13" 60.75"x59.5"x42.13" 60.75"x59.5"x42.13" 60.75"x59.5"x34" 60.75"x59.5"x34" 60.75"x59.5"x34"
60" Range with 6-33K BTU Non-Clog Burners with Wavy Grates and 24" Griddle (Left or Right)		Convection/Convection Convection/Cabinet Convection/Standard Cabinet/Cabinet Standard/Cabinet Standard/Standard	4602AA-2G/T* 4602AC-2G/T* 4602AD-2G/T* 4602CC-2G/T* 4602DC-2G/T* 4602DD-2G/T*	1075(488)	60.75"x59.5"x42.13" 60.75"x59.5"x42.13" 60.75"x59.5"x42.13" 60.75"x59.5"x34" 60.75"x59.5"x34" 60.75"x59.5"x34"
60" Range with 4-33K BTU Non-Clog Burners with Wavy Grates and 36" Griddle (Left or Right)		Convection/Convection Convection/Cabinet Convection/Standard Cabinet/Cabinet Standard/Cabinet Standard/Standard	4602AA-3G/T* 4602AC-3G/T* 4602AD-3G/T* 4602CC-3G/T* 4602DC-3G/T* 4602DD-3G/T*	1075(488)	60.75"x59.5"x42.13" 60.75"x59.5"x42.13" 60.75"x59.5"x42.13" 60.75"x59.5"x34" 60.75"x59.5"x34" 60.75"x59.5"x34"
60" Range with 2-33K BTU Non-Clog Burners with Wavy Grates and 48" Griddle (Left or Right)		Convection/Convection Convection/Cabinet Convection/Standard Cabinet/Cabinet Standard/Cabinet Standard/Standard	4602AA-4G/T* 4602AC-4G/T* 4602AD-4G/T* 4602CC-4G/T* 4602DC-4G/T* 4602DD-4G/T*	1075(488)	60.75"x59.5"x42.13" 60.75"x59.5"x42.13" 60.75"x59.5"x42.13" 60.75"x59.5"x34" 60.75"x59.5"x34" 60.75"x59.5"x34"
60" Range with 6 - 33K BTU Non-clog Burners with Wavy Grates and 24" Raised Griddle/Broiler (right only)		Convection/Convection Convection/Cabinet Convection/Standard Cabinet/Cabinet Standard/Cabinet Standard/Standard	4602AA-2RR 4602AC-2RR 4602AD-2RR 4602CC-2RR 4602DC-2RR 4602DD-2RR	1075(488)	60.75"x59.5"x42.13" 60.75"x59.5"x42.13" 60.75"x59.5"x42.13" 60.75"x59.5"x34" 60.75"x59.5"x34" 60.75"x59.5"x34"
60" Range with 6-33K BTU Star/Saute Burners and 24" Griddle (Left or Right)		Convection/Convection Convection/Cabinet Convection/Standard Cabinet/Cabinet Standard/Cabinet Standard/Standard	4603AA-2G/T* 4603AC-2G/T* 4603AD-2G/T* 4603CC-2G/T* 4603DC-2G/T* 4603DD-2G/T*	1075(488)	60.75"x59.5"x42.13" 60.75"x59.5"x42.13" 60.75"x59.5"x42.13" 60.75"x59.5"x34" 60.75"x59.5"x34" 60.75"x59.5"x34"
60" Range with 4-33K BTU Star/Saute Burners and 36" Griddle (Left or Right)		Convection/Convection Convection/Cabinet Convection/Standard Cabinet/Cabinet Standard/Cabinet Standard/Standard	4603AA-3G/T* 4603AC-3G/T* 4603AD-3G/T* 4603CC-3G/T* 4603DC-3G/T* 4603DD-3G/T*	1075(488)	60.75"x59.5"x42.13" 60.75"x59.5"x42.13" 60.75"x59.5"x42.13" 60.75"x59.5"x34" 60.75"x59.5"x34" 60.75"x59.5"x34"

\*Available on left or right. Please add "L" for left or "R" for right to the model number.

\*\*Raised broiler/griddle available on right only.

Notes: "D" = standard oven. "A" = convection oven (standard on left). "E" = space-saver oven is available in standard only.

"C" = Cabinet in lieu of oven. Cabinets standard with no doors, optional doors available at no charge.

"G" = manual griddle. "T" = thermostatic griddle

Standard oven includes 1 rack, convection oven includes 3.



The Ultimate Series - Griddle Tops

Top Configuration		Base	Model Number	Weight	Dimension (WxHxD)
60" Range with 4-33K BTU Star/Saute Burners and 48" Griddle (Left or Right)		Convection/Convection Convection/Cabinet Convection/Standard Cabinet/Cabinet Standard/Cabinet Standard/Standard	4603AA-4G/T* 4603AC-4G/T* 4603AD-4G/T* 4603CC-4G/T* 4603DC-4G/T* 4603DD-4G/T*	1075(488)	60.75"x59.5"x42.13" 60.75"x59.5"x42.13" 60.75"x59.5"x42.13" 60.75"x59.5"x34" 60.75"x59.5"x34" 60.75"x59.5"x34"
60" Range with 6-33K BTU Star/Saute Burners and 24" Raised Griddle/Broiler (right only)		Convection/Convection Convection/Cabinet Convection/Standard Cabinet/Cabinet Standard/Cabinet Standard/Standard	4603AA-2RR 4603AC-2RR 4603AD-2RR 4603CC-2RR 4603DC-2RR 4603DD-2RR	1075(488)	60.75"x59.5"x42.13" 60.75"x59.5"x42.13" 60.75"x59.5"x42.13" 60.75"x59.5"x34" 60.75"x59.5"x34" 60.75"x59.5"x34"
60" Range with 3-33K BTU Star/Saute Burners Front 3-33K BTU Non-Clog Burners in Rear and 24" Griddle (Left or Right)		Convection/Convection Convection/Cabinet Convection/Standard Cabinet/Cabinet Standard/Cabinet Standard/Standard	4604AA-2G/T* 4604AC-2G/T* 4604AD-2G/T* 4604CC-2G/T* 4604DC-2G/T* 4604DD-2G/T*	1075(488)	60.75"x59.5"x42.13" 60.75"x59.5"x42.13" 60.75"x59.5"x42.13" 60.75"x59.5"x34" 60.75"x59.5"x34" 60.75"x59.5"x34"
60" Range with 2-33K BTU Star/Saute Burners Front 2-33K BTU Non-Clog Burners in Rear with Standard Grates and 36" Griddle (Left or Right)		Convection/Convection Convection/Cabinet Convection/Standard Cabinet/Cabinet Standard/Cabinet Standard/Standard	4604AA-3G/T* 4604AC-3G/T* 4604AD-3G/T* 4604CC-3G/T* 4604DC-3G/T* 4604DD-3G/T*	1075(488)	60.75"x59.5"x42.13" 60.75"x59.5"x42.13" 60.75"x59.5"x42.13" 60.75"x59.5"x34" 60.75"x59.5"x34" 60.75"x59.5"x34"
60" Range with 1-33K BTU Star/Saute Burners Front 1-33K BTU Non-Clog Burners in Back with Standard Grates and 48" Griddle (Left or Right)		Convection/Convection Convection/Cabinet Convection/Standard Cabinet/Cabinet Standard/Cabinet Standard/Standard	4604AA-4G/T* 4604AC-4G/T* 4604AD-4G/T* 4604CC-4G/T* 4604DC-4G/T* 4604DD-4G/T*	1075(488)	60.75"x59.5"x42.13" 60.75"x59.5"x42.13" 60.75"x59.5"x42.13" 60.75"x59.5"x34" 60.75"x59.5"x34" 60.75"x59.5"x34"
60" Range with 3-33K BTU Star/Saute Burners Front 3-33K BTU Non-Clog Burners in Rear and 24" Raised Griddle/Broiler (right only)		Convection/Convection Convection/Cabinet Convection/Standard Cabinet/Cabinet Standard/Cabinet Standard/Standard	4604AA-2RR 4604AC-2RR 4604AD-2RR 4604CC-2RR 4604DC-2RR 4604DD-2RR	1075(488)	60.75"x59.5"x42.13" 60.75"x59.5"x42.13" 60.75"x59.5"x42.13" 60.75"x59.5"x34" 60.75"x59.5"x34" 60.75"x59.5"x34"
60" Range with 3-33K BTU Non-Clog Burners Front 2-40K BTU Pyromax Burners Rear and 24" Griddle (Left or Right)		Convection/Convection Convection/Cabinet Convection/Standard Cabinet/Cabinet Standard/Cabinet Standard/Standard	4605AA-2G/T* 4605AC-2G/T* 4605AD-2G/T* 4605CC-2G/T* 4605DC-2G/T* 4605DD-2G/T*	1075(488)	60.75"x59.5"x42.13" 60.75"x59.5"x42.13" 60.75"x59.5"x42.13" 60.75"x59.5"x34" 60.75"x59.5"x34" 60.75"x59.5"x34"
60" Five Burner Range with 3 - 33K BTU Sauté Burners front 2 -40K Pyromax Burners rear and 24" Griddle (Left or Right)		Convection/Convection Convection/Cabinet Convection/Standard Cabinet/Cabinet Standard/Cabinet Standard/Standard	4606AA-2G/T* 4606AC-2G/T* 4606AD-2G/T* 4606CC-2G/T* 4606DC-2G/T* 4606DD-2G/T*	1075(488)	60.75"x59.5"x42.13" 60.75"x59.5"x42.13" 60.75"x59.5"x42.13" 60.75"x59.5"x34" 60.75"x59.5"x34" 60.75"x59.5"x34"
60" Range with 4 - 40K BTU Pyromax Burners and 24" Griddle (Left or Right)		Convection/Convection Convection/Cabinet Convection/Standard Cabinet/Cabinet Standard/Cabinet Standard/Standard	4607AA-2G/T* 4607AC-2G/T* 4607AD-2G/T* 4607CC-2G/T* 4607DC-2G/T* 4607DD-2G/T*	1075(488)	60.75"x59.5"x42.13" 60.75"x59.5"x42.13" 60.75"x59.5"x42.13" 60.75"x59.5"x34" 60.75"x59.5"x34" 60.75"x59.5"x34"
60" Range with 3-33K BTU Non-Clog Burners Front 2-40K BTU Pyromax Burners Rear and 24" Raised Griddle/Broiler (right only)		Convection/Convection Convection/Cabinet Convection/Standard Cabinet/Cabinet Standard/Cabinet Standard/Standard	4605AA-2RR 4605AC-2RR 4605AD-2RR 4605CC-2RR 4605DC-2RR 4605DD-2RR	1075(488)	60.75"x59.5"x42.13" 60.75"x59.5"x42.13" 60.75"x59.5"x42.13" 60.75"x59.5"x34" 60.75"x59.5"x34" 60.75"x59.5"x34"
60" Range with 3-33K BTU Star/Saute Burners Front 2-40K BTU Pyromax Burners Rear with Standard Grates and 24" Raised Griddle/ Broiler (right only)		Convection/Convection Convection/Cabinet Convection/Standard Cabinet/Cabinet Standard/Cabinet Standard/Standard	4606AA-2RR 4606AC-2RR 4606AD-2RR 4606CC-2RR 4606DC-2RR 4606DD-2RR	1075(488)	60.75"x59.5"x42.13" 60.75"x59.5"x42.13" 60.75"x59.5"x42.13" 60.75"x59.5"x34" 60.75"x59.5"x34" 60.75"x59.5"x34"
60" Range with 4-40K BTU Pyromax Burners Rear with Standard Grates and 24" Raised Griddle/ Broiler (right only)		Convection/Convection Convection/Cabinet Convection/Standard Cabinet/Cabinet Standard/Cabinet Standard/Standard	4607AA-2RR 4607AC-2RR 4607AD-2RR 4607CC-2RR 4607DC-2RR 4607DD-2RR	1075(488)	60.75"x59.5"x42.13" 60.75"x59.5"x42.13" 60.75"x59.5"x42.13" 60.75"x59.5"x34" 60.75"x59.5"x34" 60.75"x59.5"x34"



# The Ultimate Series - Charbroilers Tops



4361D-2CR  
w/ optional casters

## Standard Features

- 32,000 BTU per foot
- Stainless steel tube burner and radiant fins
- Uniform cast iron waffle grates
- Dual branding cast iron grates (flat or inclined)

Top Configuration		Base	Model Number	Weight	Dimension (WxHxD)
36" Range with 2 - 33K BTU Non-clog Burners with Standard Grates and 24" Charbroiler (Left or Right)		Convection Cabinet Standard	4361A-2C* 4361C-2C* 4361D-2C*	660(300)	36.5"x59.5"x42.13" 36.5"x59.5"x34" 36.5"x59.5"x34"
36" Range with 2 - 27K BTU Non-clog Burners with Wavy Grates and 24" Charbroiler (Left or Right)		Convection Cabinet Standard	4362A-2C* 4362C-2C* 4362D-2C*	660(300)	36.5"x59.5"x42.13" 36.5"x59.5"x34" 36.5"x59.5"x34"
36" Range with 2-33K BTU Star/Saute Burners with Standard Grates and 24" Charbroiler (Left or Right)		Convection Cabinet Standard	4363A-2C* 4363C-2C* 4363D-2C*	660(300)	36.5"x59.5"x42.13" 36.5"x59.5"x34" 36.5"x59.5"x34"
36" Range with 1-33K BTU Star/Saute Burners 1-33K BTU Non-Clog Burners with Standard Grates and 24" Charbroiler (Left or Right)		Convection Cabinet Standard	4364A-2C* 4364C-2C* 4364D-2C*	660(300)	36.5"x59.5"x42.13" 36.5"x59.5"x34" 36.5"x59.5"x34"
36" Range with 36" Charbroiler		Convection Cabinet Standard	436A-3C* 436C-3C* 436D-3C*	660(300)	36.5"x59.5"x42.13" 36.5"x59.5"x34" 36.5"x59.5"x34"
48" Range with 4 - 33K BTU Non-clog Burners with Standard Grates and 24" Charbroiler (Left or Right)		Convection/Cabinet Standard/Cabinet Dual Space Saver	4481AC-2C* 4481DC-2C* 4481EE-2C*	735(334)	48.625"x59.5"x42.13" 48.625"x59.5"x34" 48.625"x59.5"x34"
48" Range with 2 - 33K BTU Non-clog Burners with Standard Grates and 36" Charbroiler (Left or Right)		Convection/Cabinet Standard/Cabinet Dual Space Saver	4481AC-3C* 4481DC-3C* 4481EE-3C*	735(334)	48.625"x59.5"x42.13" 48.625"x59.5"x34" 48.625"x59.5"x34"
48" Range with 4 - 27K BTU Non-clog Burners with Wavy Grates and 24" Charbroiler (Left or Right)		Convection/Cabinet Standard/Cabinet Dual Space Saver	4482AC-2C* 4482DC-2C* 4482EE-2C*	735(334)	48.625"x59.5"x42.13" 48.625"x59.5"x34" 48.625"x59.5"x34"
48" Range with 2 - 27K BTU Non-clog Burners with Wavy Grates and 36" Charbroiler (Left or Right)		Convection/Cabinet Standard/Cabinet Dual Space Saver	4482AC-3C* 4482DC-3C* 4482EE-3C*	735(334)	48.625"x59.5"x42.13" 48.625"x59.5"x34" 48.625"x59.5"x34"
48" Range with 4-33 K BTU Star/Saute Burners with Standard Grates and 24" Charbroiler (Left or Right)		Convection/Cabinet Standard/Cabinet Dual Space Saver	4483AC-2C* 4483DC-2C* 4483EE-2C*	735(334)	48.625"x59.5"x42.13" 48.625"x59.5"x34" 48.625"x59.5"x34"
48" Range with 2-33 K BTU Star/Saute Burners with Standard Grates and 36" Charbroiler (Left or Right)		Convection/Cabinet Standard/Cabinet Dual Space Saver	4483AC-3C* 4483DC-3C* 4483EE-3C*	735(334)	48.625"x59.5"x42.13" 48.625"x59.5"x34" 48.625"x59.5"x34"
48" Range with 2-33K BTU Star/Saute Burners in front 2-33K BTU Non-clog Burners in Rear with Standard Grates and 24" Charbroiler (Left or Right)		Convection/Cabinet Standard/Cabinet Dual Space Saver	4484AC-2C* 4484DC-2C* 4484EE-2C*	735(334)	48.625"x59.5"x42.13" 48.625"x59.5"x34" 48.625"x59.5"x34"
48" Range with 1-33K BTU Star/Saute Burners in front 1-33K BTU Non-clog Burners in Rear with Standard Grates and 36" Charbroiler (Left or Right)		Convection/Cabinet Standard/Cabinet Dual Space Saver	4484AC-3C* 4484DC-3C* 4484EE-3C*	735(334)	48.625"x59.5"x42.13" 48.625"x59.5"x34" 48.625"x59.5"x34"

\*Available on left or right. Please add "L" for left or "R" for right to the model number.

Notes: "D" = standard oven. "A" = convection oven (standard on left). "E" = space-saver oven is available in standard only.

"C" = Cabinet in lieu of oven. Cabinets standard with no doors, optional doors available at no charge.

Standard oven includes 1 racks, convection oven includes 3.



## The Ultimate Series - Charbroilers Tops

Top Configuration		Base	Model Number	Weight	Dimension (WxHxD)
60" Range with 6 - 33K BTU Non-clog Burners with Standard Grates and 24" Charbroiler (Left or Right)		Convection/Convection Convection/Cabinet Convection/Standard Cabinet/Cabinet Standard/Cabinet Standard/Standard	4601AA-2C* 4601AC-2C* 4601AD-2C* 4601CC-2C* 4601DC-2C* 4601DD-2C*	1075(488)	60.75"x59.5"x42.13" 60.75"x59.5"x42.13" 60.75"x59.5"x42.13" 60.75"x59.5"x34" 60.75"x59.5"x34" 60.75"x59.5"x34"
60" Range with 4 - 33K BTU Non-clog Burners with Standard Grates and 36" Charbroiler (Left or Right)		Convection/Convection Convection/Cabinet Convection/Standard Cabinet/Cabinet Standard/Cabinet Standard/Standard	4601AA-3C* 4601AC-3C* 4601AD-3C* 4601CC-3C* 4601DC-3C* 4601DD-3C*	1075(488)	60.75"x59.5"x42.13" 60.75"x59.5"x42.13" 60.75"x59.5"x42.13" 60.75"x59.5"x34" 60.75"x59.5"x34" 60.75"x59.5"x34"
60" Range with 6 - 27K BTU Non-clog Burners with Wavy Grates and 24" Charbroiler (Left or Right)		Convection/Convection Convection/Cabinet Convection/Standard Cabinet/Cabinet Standard/Cabinet Standard/Standard	4602AA-2C* 4602AC-2C* 4602AD-2C* 4602CC-2C* 4602DC-2C* 4602DD-2C*	1075(488)	60.75"x59.5"x42.13" 60.75"x59.5"x42.13" 60.75"x59.5"x42.13" 60.75"x59.5"x34" 60.75"x59.5"x34" 60.75"x59.5"x34"
60" Range with 4 - 27K BTU Non-clog Burners with Wavy Grates and 36" Charbroiler (Left or Right)		Convection/Convection Convection/Cabinet Convection/Standard Cabinet/Cabinet Standard/Cabinet Standard/Standard	4602AA-3C* 4602AC-3C* 4602AD-3C* 4602CC-3C* 4602DC-3C* 4602DD-3C*	1075(488)	60.75"x59.5"x42.13" 60.75"x59.5"x42.13" 60.75"x59.5"x42.13" 60.75"x59.5"x34" 60.75"x59.5"x34" 60.75"x59.5"x34"
60" Range with 6-33K BTU Star/Saute Burners Front with Standard Grates and 24" Charbroiler (Left or Right)		Convection/Convection Convection/Cabinet Convection/Standard Cabinet/Cabinet Standard/Cabinet Standard/Standard	4603AA-2C* 4603AC-2C* 4603AD-2C* 4603CC-2C* 4603DC-2C* 4603DD-2C*	1075(488)	60.75"x59.5"x42.13" 60.75"x59.5"x42.13" 60.75"x59.5"x42.13" 60.75"x59.5"x34" 60.75"x59.5"x34" 60.75"x59.5"x34"
60" Range with 4-33K BTU Star/Saute Burners Front with Standard Grates and 36" Charbroiler (Left or Right)		Convection/Convection Convection/Cabinet Convection/Standard Cabinet/Cabinet Standard/Cabinet Standard/Standard	4603AA-3C* 4603AC-3C* 4603AD-3C* 4603CC-3C* 4603DC-3C* 4603DD-3C*	1075(488)	60.75"x59.5"x42.13" 60.75"x59.5"x42.13" 60.75"x59.5"x42.13" 60.75"x59.5"x34" 60.75"x59.5"x34" 60.75"x59.5"x34"
60" Range with 3-33K BTU Star/Saute Burners Front 3-33K BTU Non-Clog Burners in Rear and 24" Charbroiler (Left or Right)		Convection/Convection Convection/Cabinet Convection/Standard Cabinet/Cabinet Standard/Cabinet Standard/Standard	4604AA-2C* 4604AC-2C* 4604AD-2C* 4604CC-2C* 4604DC-2C* 4604DD-2C*	1075(488)	60.75"x59.5"x42.13" 60.75"x59.5"x42.13" 60.75"x59.5"x42.13" 60.75"x59.5"x34" 60.75"x59.5"x34" 60.75"x59.5"x34"
60" Range with 2-33K BTU Star/Saute Burners Front 2-33K BTU Non-Clog Burners in Rear and 36" Charbroiler (Left or Right)		Convection/Convection Convection/Cabinet Convection/Standard Cabinet/Cabinet Standard/Cabinet Standard/Standard	4604AA-3C* 4604AC-3C* 4604AD-3C* 4604CC-3C* 4604DC-3C* 4604DD-3C*	1075(488)	60.75"x59.5"x42.13" 60.75"x59.5"x42.13" 60.75"x59.5"x42.13" 60.75"x59.5"x34" 60.75"x59.5"x34" 60.75"x59.5"x34"
60" Five Burner Range with 3 - 33K BTU Non-clog Burners front 2 -40K Pyromax Burners rear and 24" Charbroiler (Left or Right)		Convection/Convection Convection/Cabinet Convection/Standard Cabinet/Cabinet Standard/Cabinet Standard/Standard	4605AA-2C* 4605AC-2C* 4605AD-2C* 4605CC-2C* 4605DC-2C* 4605DD-2C*		60.75"x59.5"x42.13" 60.75"x59.5"x42.13" 60.75"x59.5"x42.13" 60.75"x59.5"x34" 60.75"x59.5"x34" 60.75"x59.5"x34"
60" Five Burner Range with 3 - 33K BTU Sauté Burners front 2 -40K Pyromax Burners rear and 24" Charbroiler (Left or Right)		Convection/Convection Convection/Cabinet Convection/Standard Cabinet/Cabinet Standard/Cabinet Standard/Standard	4606AA-2C* 4606AC-2C* 4606AD-2C* 4606CC-2C* 4606DC-2C* 4606DD-2C*	1075(488)	60.75"x59.5"x42.13" 60.75"x59.5"x42.13" 60.75"x59.5"x42.13" 60.75"x59.5"x34" 60.75"x59.5"x34" 60.75"x59.5"x34"
60" Five Burner Range with 4 -40K Pyromax Burners and 24" Charbroiler (Left or Right)		Convection/Convection Convection/Cabinet Convection/Standard Cabinet/Cabinet Standard/Cabinet Standard/Standard	4607AA-2C* 4607AC-2C* 4607AD-2C* 4607CC-2C* 4607DC-2C* 4607DD-2C*	1075(488)	60.75"x59.5"x42.13" 60.75"x59.5"x42.13" 60.75"x59.5"x42.13" 60.75"x59.5"x34" 60.75"x59.5"x34" 60.75"x59.5"x34"

\*Available on left or right. Please add "L" for left or "R" for right to the model number.

Notes: "D" = standard oven. "A" = convection oven (standard on left). "E" = space-saver oven is available in standard only.

"C" = Cabinet in lieu of oven. Cabinets standard with no doors, optional doors available at no charge.

Standard oven includes 1 racks, convection oven includes 3.



# THE INDUSTRY'S ONLY 5 BURNER RANGE

Built for Large Stock Pots and Simultaneous Sautéing



## The Ultimate Series - 72" Range



4721DD  
w/ optional casters

### Standard Features

- Restaurant range 73" wide with a 37" high cooking top
- 4" Stainless steel front rail, stainless steel front and sides
- (2) Front located, manual, gas shut-off valves for each side of the range
- Factory installed regulator
- Battery spark ignition for oven bases
- (6) 6" high stainless legs

Top Configuration		Base	Model Number	Weight	Dimension (WxHxD)
72" Range with 12 - 33K BTU Non-clog Burners		Convection/Convection Standard/Standard	4721AA 4721DD	1320(600)	73"x59.5"x42.13" 73"x59.5"x34"
72" Range with 6 - 33K BTU Non-clog Burners with Standard Grates and 5 Burner Configuration (Left or Right) to include 2-40K Pyromax Rear and 3-33K BTU Non-clog Burners		Convection/Convection Standard/Standard	4721AA-5* 4721DD-5*	1320(600)	73"x59.5"x42.13" 73"x59.5"x34"
72" Range with 4-40K Pyromax Rear and 6-33K BTU Non-clog Burners		Convection/Convection Standard/Standard	4725AA 4725DD	1320(600)	73"x59.5"x42.13" 73"x59.5"x34"
72" Range with 6 - 33K BTU Non-clog Burners with Standard Grates and 36" Griddle (Left or Right)		Convection/Convection Standard/Standard	4721AA-3G/T* 4721DD-3G/T*	1320(600)	73"x59.5"x42.13" 73"x59.5"x34"
72" Range with 3 - 33K BTU Non-clog Burners 2 -40K Pyromax Burners rear and 36" Griddle (Left or Right)		Convection/Convection Standard/Standard	4725AA-3G/T* 4725DD-3G/T*	1320(600)	73"x59.5"x42.13" 73"x59.5"x34"
72" Range with 6 - 33K BTU Non-clog Burners with Standard Grates and 36" Charbroiler (Left or Right)		Convection/Convection Standard/Standard	4721AA-3C* 4721DD-3C*	1320(600)	73"x59.5"x42.13" 73"x59.5"x34"
72" Range with 3 - 33K BTU Non-clog Burners 2 -40K Pyromax Burners rear and 36" Charbroiler (Left or Right)		Convection/Convection Standard/Standard	4725AA-3C* 4725DD-3C*	1320(600)	73"x59.5"x42.13" 73"x59.5"x34"

\*Available on left or right. Please add "L" for left or "R" for right to the model number.

Notes: "D" = standard oven. "A" = convection oven (standard on left).

"G" = manual griddle. "T" = thermostatic griddle

Standard oven includes 1 rack, convection oven includes 3 racks.



## Ultimate Range Series

Optional 1" Griddle Top  
 12"  
 24"  
 36"  
 48"

Optional Step-Up Burners  
 24" 4-Burner  
 36" 6-Burner  
 48" 8-Burner  
 60" 10-Burner  
 72" 12-Burner

Casters (in lieu of legs)  
 2 locking and 2 standard (24", 36", 48" and 60" units)  
 3 locking and 3 standard (72" units)

10" riser in lieu of standard 22.5" riser with shelf (not available with raised griddle/broiler)

5" riser in lieu of standard 22.5" riser with shelf (not available with raised griddle/broiler)

Stainless steel rear (includes riser's rear)  
 24" wide range  
 36" wide range  
 48" wide range  
 60" wide range  
 72" wide range

Extra rack for Standard Oven

Extra rack for Convection Oven

3/4" quick disconnect with 4' hose

3/4" quick disconnect with 5' hose

3' restraining device

**Extended Plate Shelves**

424 with solid rail or cutouts

424 with cutting board

436 with solid rail or cutouts

436 with cutting board

448 with solid rail or cutouts

448 with cutting board

460 with solid rail or cutouts

460 with cutting board

472 with solid rail or cutouts

472 with cutting board

Charbroiler Options  
 6" round rod grates  
 12" round rod grates  
 24" round rod grate  
 36" round rod grate

Auxiliary griddle plate (3/16" plate with handles -12"x24"x1")

Factory installed hot tops or stainless steel worktops  
 Each top replaces two burners, front to back (12"x27")  
 Hot tops are not available with griddle top or charbroiler ranges.

Flame failure on type #1 and #2 open top burners, 2' and 3' manual griddles for the Ultimate Range (Contact customer service for available models: 919-762-1000)  
 12" Width Range  
 24" Width Range  
 36" Width Range  
 48" Width Range  
 60" Width Range  
 72" Width Range

Battery Spark Ignition (Open Tops, Charbroilers, Griddles and Hot Tops)  
 12" Section  
 24" Section  
 36" Section  
 48" Section  
 60" Section  
 72" Section



# The S-Series Range



S36D  
w/ optional casters

### Standard Features

- Available in four sizes: 24", 36", 48" and 60"
- Stainless steel front, sides and legs
- 28,000 BTU **PATENTED**, one-piece, non-clog burner with lifetime warranty
- 35,000 BTU oven base with heavy-duty burner and all enameled oven cavity
- 22.5" stainless steel flue riser with heavy-duty shelf
- 4" stainless steel front rail with closed, welded, and polished end caps, with no sharp or exposed corners
- Heat resistant, metal knobs and ergonomic handle
- Removable one piece crumb drawer
- High efficiency snap action thermostat adjustable from 175°F to 550°F
- Quadrant spring doors

### Competitive Information







Standard Features:	Southbend S36D	Sunfire X36-6R	American Range AR-6	Imperial IR-6
Stainless steel front, sides, legs	Yes	Yes	Yes	Yes
Lifetime burner warranty	Yes	No	No	No
Cooking surface depth	27"	27"	24"	24"
Open burner BTUs	28K	30K	32K	32K
Standard oven BTUs	35K	33K	35K	35K
Fully porcelainized oven cavity	Yes	No	Yes	No

### Options and Accessories

S Series Options and Accessories
Casters (in lieu of legs) - 2 locking and 2 standard
10" riser in lieu of standard 22.5" riser with shelf (not available with raised griddle/broiler) (no charge)
5" riser in lieu of standard 22.5" riser with shelf (not available with raised griddle/broiler) (no charge)
Extra rack for Standard Oven
Extra rack for Convection Oven
3/4" quick disconnect with 4' hose
3/4" quick disconnect with 5' hose
3' restraining device

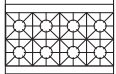
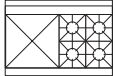
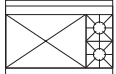

# S-Series Restaurant Ranges

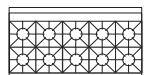
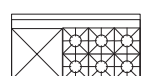
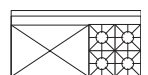
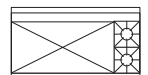
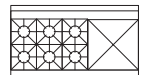
Configuration	Oven Base	Model Number	Weight	Dimension (WxHxD)
24" Range with 4 Burners 	Cabinet Space Saver	S24C S24E	475(216)	24.5"x59.5"x34" 24.5"x59.5"x34"
36" Range with 6 Burners 	Convection Cabinet Standard	S36A S36C S36D	660(300)	36.5"x59.5"x34" 36.5"x59.5"x44" 36.5"x59.5"x34"
36" Range with 4 Burners and 12" griddle (left side only) 	Convection Cabinet Standard	S36A-1G S36C-1G S36D-1G	660(300)	36.5"x59.5"x34" 36.5"x59.5"x44" 36.5"x59.5"x34"
36" Range with 2 Burners and 24" griddle 	Convection Cabinet Standard	S36A-2G/T* S36C-2G/T* S36D-2G/T*	660(300)	36.5"x59.5"x34" 36.5"x59.5"x44" 36.5"x59.5"x34"
36" Range with 36" griddle 	Convection Cabinet Standard	S36A-3G/T S36C-3G/T S36D-3G/T	660(300)	36.5"x59.5"x34" 36.5"x59.5"x44" 36.5"x59.5"x34"
48" Range with 8 Burners 	Convection/Cabinet Standard/Cabinet Dual Space Saver	S48AC S48DC S48EE	860(390)	48.5"x59.5"x34" 48.5"x59.5"x44" 48.5"x59.5"x34"
48" Range with 4 Burners and 24" griddle 	Convection/Cabinet Standard/Cabinet Dual Space Saver	S48AC-2G/T* S48DC-2G/T* S48EE-2G/T*	860(390)	48.5"x59.5"x34" 48.5"x59.5"x44" 48.5"x59.5"x34"
48" Range with 2 Burners and 36" griddle 	Convection/Cabinet Standard/Cabinet Dual Space Saver	S48AC-3G/T* S48DC-3G/T* S48EE-3G/T*	860(390)	48.5"x59.5"x34" 48.5"x59.5"x44" 48.5"x59.5"x34"
48" Range with 48" Griddle 	Convection/Cabinet Standard/Cabinet Dual Space Saver	S48AC-4G/T S48DC-4G/T S48EE-4G/T	860(390)	48.5"x59.5"x34" 48.5"x59.5"x44" 48.5"x59.5"x34"
60" Range with 10 Burners 	Dual Convection Convection/Cabinet Convection/Standard Cabinet/Cabinet Standard/Cabinet Dual Standard	S60AA S60AC S60AD S60CC S60DC S60DD	1075(488)	60.75"x59.5"x34" 60.75"x59.5"x44" 60.75"x59.5"x44" 60.75"x59.5"x34" 60.75"x59.5"x44" 60.75"x59.5"x34"
60" Range with 6 Burners and 24" griddle 	Dual Convection Convection/Cabinet Convection/Standard Cabinet/Cabinet Standard/Cabinet Dual Standard	S60AA-2G/T* S60AC-2G/T* S60AD-2G/T* S60CC-2G/T* S60DC-2G/T* S60DD-2G/T*	1075(488)	60.75"x59.5"x34" 60.75"x59.5"x44" 60.75"x59.5"x44" 60.75"x59.5"x34" 60.75"x59.5"x44" 60.75"x59.5"x34"
60" Range with 4 Burners and 36" griddle 	Dual Convection Convection/Cabinet Convection/Standard Cabinet/Cabinet Standard/Cabinet Dual Standard	S60AA-3G/T* S60AC-3G/T* S60AD-3G/T* S60CC-3G/T* S60DC-3G/T* S60DD-3G/T*	1075(488)	60.75"x59.5"x34" 60.75"x59.5"x44" 60.75"x59.5"x44" 60.75"x59.5"x34" 60.75"x59.5"x44" 60.75"x59.5"x34"
60" Range with 2 Burners and 48" griddle 	Dual Convection Convection/Cabinet Convection/Standard Cabinet/Cabinet Standard/Cabinet Dual Standard	S60AA-4G/T* S60AC-4G/T* S60AD-4G/T* S60CC-4G/T* S60DC-4G/T* S60DD-4G/T*	1075(488)	60.75"x59.5"x34" 60.75"x59.5"x44" 60.75"x59.5"x44" 60.75"x59.5"x34" 60.75"x59.5"x44" 60.75"x59.5"x34"
60" Range with 6 Burners and 24" raised broiler/griddle (Right Only) 	Dual Convection Convection/Cabinet Convection/Standard Cabinet/Cabinet Standard/Cabinet Dual Standard	S60AA-2RR** S60AC-2RR** S60AD-2RR** S60CC-2RR** S60DC-2RR** S60DD-2RR**	1075(488)	60.75"x59.5"x34" 60.75"x59.5"x44" 60.75"x59.5"x44" 60.75"x59.5"x34" 60.75"x59.5"x44" 60.75"x59.5"x34"

\*Griddles available on left or right. Please add "L" for left or "R" for right to the model number.

\*\*Raised broiler/griddle available on right only.

Notes: "D" = standard oven. "A" = convection oven (standard on left). "E" = space-saver oven and is available in standard only. "C" = Cabinet in lieu of oven. Cabinets standard with no doors, optional doors available at no charge. "G" = manual griddle. "T" thermostatic griddle. Standard oven includes 1 rack, convection oven includes 2 racks.



# Fryers

---



# Mid-Tier Gas Fryers

## 40lb-50lb & 70lb-90lb Heavy Duty Gas Fryers



SB14R Shown with legs  
(optional casters available)

### Standard Features

- Welded stainless steel tank with an extra smooth peened finish to ensure easy cleaning
- Stainless steel cabinet door, sides, front and rear panels
- Solstice Burner Technology (no blower or ceramics)
- Millivolt Thermostat (T-Stat) 200°F-400°F (93°C-190°C)
- Thermo-Safety pilot with built in regulator
- High Temperature safety limit switch
- Heavy-duty 3/16" bottom door hinge
- 1-1/4" (3.2 cm) full port, front drain valve - for quick draining
- Separate manual gas shutoffs for front servicing
- Integrated flue deflector
- 9" (22.9 cm) adjustable legs, easier access to clean
- Tube rack, allows crumbs & debris into cool zone
- Removable basket hanger, requires no tools
- Drain line clean out rod
- Drain extension
- Fryer cleaner sample packet
- Includes two twin plated wire mesh fry baskets with plastic-coated handles

### SB14R & SB18

Model Number	Description	BTU	Shipping Wt.
SB14R	40lb to 50lb Fryer (Oil Capacity)	122,000	208 lbs.
SB18	70lbs to 90lb Fryer (Oil Capacity)	140,000	275 lbs.

Portable filter units available. Filter prices are on page 44.

### Options and Accessories

ACCESSORIES
9" Casters (Set of 4)



# Pasta Cooker and Rinse Station

## NOD14 & NODR14



NOD14/NODR14  
(Available as stand alone units only)

### Standard Features

- Marine grade stainless steel tank
- Stainless steel exterior cabinet
- Solstice burner technology, no blower or ceramics
- High efficiency design
- Self cleaning burner & down draft protection
- Digital controller with 4 button timer
- Drain "T" manifold (standard on NOD14 cooker/ NODR14 rinse station)
- Manual water fill
- Tank overflow with screen
- Drain screen and clean out rod
- Tube rack (cooker)
- Removable basket hanger
- 9" adjustable legs for easier cleaning
- Single gas connection when ordering multiple cookers
- Faucet on rinse station

## NOD14 & NODR14

Model Number	Description	BTU	Shipping Wt.
NOD14	Pasta Cooker (12 Gallon)	60,000 per frypot	250 lbs.
NODR14	Rinse Station (10 Gallon)	n/a	136 lbs.

## Options and Accessories

Accessories
6" Casters (Set of 4)





# High Volume Griddle



HDG-48V

## Standard Features

- 30,000 BTU (NAT) burner per 12"
- 1" thick polished rolled steel plate
- Reinforced, insulated double wall sides
- Stainless steel integrated stand
- 5" high rear and 4" side splash guards
- Stainless steel front, vent and sides are standard, rear and bottom panels are aluminized steel.
- Two large grease containment receptacles (16 quarts each) for high volume use
- Each burner equipped with runner tube
- Fully welded griddle plate with protected exhaust vent
- Electronic spark ignition (battery)
- Exclusive "NO COLD" Zone -Uniform heat distribution across surface
- Stainless steel front towel bar
- Embedded load sensing thermostat
- Snap-action thermostatic controls for precise settings between 200°F and 550°F, with embedded load sensing thermostat
- Flame failure safety device
- 3/4" rear gas connection and pressure regulator
- Protected flue opening

## Griddle

Description	Model Number	Weight	Dimension WxHxD
24" Countertop Griddle 60,000 BTU	HDG-24V	335 (152)	24"x40.6"x33.5"
36" Countertop Griddle 90,000 BTU	HDG-36V	490 (222)	36"x40.6"x33.5"
48" Countertop Griddle 120,000 BTU	HDG-48V	600 (272)	48"x40.6"x33.5"
60" Countertop Griddle 150,000 BTU	HDG-60V	780 (354)	60"x40.6"x33.5"

## Options and Accessories

Options and Accessories
<b>Grooved griddle plates (requires extended lead times)</b> Single Up to 12" of grooving 13" to 24" of grooving 25" to 36" of grooving
<b>Chrome plated griddle plates (requires extended lead times)</b> 24" 36" 48" 60" 72"



# Heavy Duty Griddle



HDG-36  
w/ optional stand and casters

## Exclusive No Cold Zone

Standard Griddle

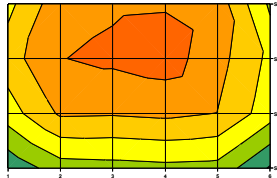

Southbend Griddle

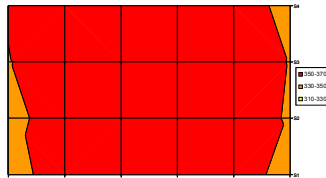

### Standard Features

- 30,000 BTU (NAT or LP) burner per 12" Thermostatic Models
- 20,000 BTU (NAT or LP) burner per 12" Manual Models
- Stainless steel front and sides with reinforced, insulated walls
- 1" thick polished rolled steel plate
- Integrated 4" high splash guards standard
- Snap-action thermostatic controls for precise settings between 200°F and 550°F, with embedded load sensing thermostat
- 4" Spatula width front grease trough standard, rear trough optional
- Large capacity grease drawer - (1 for 24"-48", 2 for 60"-72")
- Chrome griddle plate and grooved griddle plate options available
- Can be operated with or without legs
- Manual griddles will climb in temperature if product is not placed on the plate to remove the incoming heat
- Manual griddles do not have a temperature control feature

### Griddles

Description	Model Number	Weight	Dimension WxHxD
24" Deep Griddles			
18" Countertop Griddle	HDG-18 / HDG-18-M 30,000 BTU / 20,000 BTU	270 (122)	18"x16.125"x33.75"
24" Countertop Griddle	HDG-24 / HDG-24-M 60,000 BTU / 40,000 BTU	305 (139)	24"x16.125"x33.75"
36" Countertop Griddle	HDG-36 / HDG-36-M 90,000 BTU / 60,000 BTU	445 (202)	36"x16.125"x33.75"
48" Countertop Griddle	HDG-48 / HDG-48-M 120,000 BTU / 80,000 BTU	545 (247)	48"x16.125"x33.75"
60" Countertop Griddle	HDG-60 / HDG-60-M 150,000 BTU / 100,000 BTU	705 (320)	60"x16.125"x33.75"
72" Countertop Griddle	HDG-72 / HDG-72-M 180,000 BTU / 120,000 BTU	840 (378)	72"x16.125"x33.75"
30" Deep Griddle			
24" Countertop Griddle - 30" Deep	HDG-24-30	405 (183)	24"x40.6"x45"
36" Countertop Griddle - 30" Deep	HDG-36-30	545 (247)	36"x40.6"x45"
48" Countertop Griddle - 30" Deep	HDG-48-30	682 (309)	48"x40.6"x45"
60" Countertop Griddle - 30" Deep	HDG-60-30	880 (399)	60"x40.6"x45.5"

### Competitive Information

Standard Features	Southbend HDG	Garland GTG	Imperial ISAE-36	Vulcan 936RX	Wolf ASA
Stainless steel front and sides	Yes	Yes	Yes	Yes	Yes
24" deep griddle plate	Yes	No	Yes	Yes	Yes
1" thick griddle plate	Yes	Yes	Yes	Yes	Yes
BTU's per foot	30,000	27,000	24,000	27,000	27,000
Instant response t-stats requiring no electricity	Yes	Yes	Yes	Yes	Yes
Flame failure safety device	Yes	Yes	Yes	Yes	Yes
Battery spark ignition	Yes	Yes	Yes	Yes	No
Can be used without legs	Yes	No	No	No	No



# Heavy Duty Charbroiler



HDC-36  
w/ optional stand and casters

### Standard Features

- 20,000 BTU (NAT or LP) stainless steel burner per 6"
- Stainless steel front and sides with reinforced, insulated walls
- Cast iron radiants and ceramic briquette units available - field convertible with no special tools required
- Integrated 4" high splash guards standard
- Two-position, two sided cooking grids for wide or narrow branding
- Large capacity grease drawer. (1 for 24"-48", 2 for 60")
- Can be operated with or without legs

## Charbroilers

Description	Model Number	Weight	Dimension WxHxD
12" Countertop Charbroiler 40,000 BTU	HDC-12 / HDCL-12*	165 (75)	12"x16.125"x33.25"
18" Countertop Charbroiler 60,000 BTU	HDC-18 / HDCL-18*	200 (91)	18"x16.125"x33.25"
24" Countertop Charbroiler 80,000 BTU	HDC-24 / HDCL-24*	240 (109)	24"x16.125"x33.25"
30" Countertop Charbroiler 100,000 BTU	HDC-30 / HDCL-30*	305 (138)	30"x16.125"x33.25"
36" Countertop Charbroiler 120,000 BTU	HDC-36 / HDCL-36*	350 (159)	36"x16.125"x33.25"
48" Countertop Charbroiler 160,000 BTU	HDC-48 / HDCL-48*	425 (193)	48"x16.125"x33.25"
60" Countertop Charbroiler 200,000 BTU	HDC-60 / HDCL-60*	500 (135)	60"x16.125"x33.25"

\* includes ceramic briquettes.

## Competitive Information

Standard Features:	Southbend HDC-36	Garland GTB	Imperial IRB-36	Vulcan VCCB36
Stainless steel front and sides	Yes	Yes	Yes	Yes
Burner control every 6"	Yes	Yes	Yes	Yes
BTU's per 6"	20,000	18,000	15,000	14,500
Two-position, two sided reversible cooking grids	Yes	Yes	Yes	Yes
Field convertible from radiant to briquette	Yes	No	Yes	No
Can be used without legs	Yes	No	Yes	No
Cast iron radiants	Yes	Yes	Yes	Yes
Stainless steel burner	Yes	Yes	Yes	Yes
4" Stainless steel rear and side splash guard	Yes	No	No	No



# Heavy Duty Open Top



HDO-36  
w/ optional stand and casters

## Standard Features

- **PATENTED** 33,000 BTU NAT (24,000 BTU LP) open top non-clogging burner
- 3/4" rear regulator
- Heavy-duty metal knobs
- Hi/Low burner controls
- Stainless steel front and sides
- Full width crumb tray
- 12" cast flush top grates
- 4" stainless steel legs
- Can be operated with or without legs

## Open Top

Description	Model Number	Weight	Dimension WxHxD
12" Open Top with 2-33,000 BTU Burners	HDO-12	165 (75)	12"x11"x33.75"
24" Open Top with 4-33,000 BTU Burners	HDO-24 / HDO-24SU*	209 (94)	24"x11"x33.75" 24"x15"x33.75"
36" Open Top with 6-33,000 BTU Burners	HDO-36 / HDO-36SU*	253 (115)	36"x11"x33.75" 36"x15"x33.75"
48" Open Top with 8-33,000 BTU Burners	HDO-48 / HDO-48SU*	299 (135)	48"x11"x33.75" 48"x15"x33.75"

\* step-up units

## Competitive Information

Standard Features:	Southbend HDO-36	Garland GTOG36-6	Vulcan VHP
Stainless steel front and sides	Yes	Yes	Yes
Flush top, individual, cast-iron grates	Yes	Yes	No
BTU's per foot	33,000	30,000	30,000
Lifetime warranty on burner	Yes	No	No
Full width crumb tray	Yes	Yes	Yes
Can be used without legs	Yes	No	No



# All Terrain Oven



PCG50S/SDAT  
All Terrain

## Standard Features

- 54,000 BTU (LP) Standard depth
- Single deck convection oven is 55-1/4" in height
- Patented "plug-in, plug-out" control panel - easy to service
- Slide out control panel for full view servicing
- Stainless steel front, sides and top
- Full stainless steel dependent doors (Full 180° opening)
- Transportation door locks (Pad lock not included)
- Fully enclosed stainless steel rear jacket for transportation protection
- Heat keeping dual door seal system
- Top and bottom rear covers for utility protection
- Coved, porcelain interior
- Stay cool heavy duty door handle
- Soft Air, two-speed, 1/2 hp fan motor
- Custom design rugged terrain tube chassis
- Integrated equipment shelf on tube chassis
- 11-position rack guides and 5 plated oven racks
- Electronic ignition
- Forced cool down fan mode
- Oven "heat" light cycles with burners
- All Terrain 10" casters (1000 lbs maximum capacity) for easy transportation
- Interior oven lights
- One year parts and labor warranty

## Gas Models

Description	Model Number	Control Panel	Deck Depth	Weight	Dimension WxHxD
Gas - 54,000 BTU Single Deck	PCG50S/SDAT	standard	standard	750 (340)	38"x55.25"x38.5"

## Options and Accessories

Options and Accessories
3/4" quick disconnect with flexible hose
4' quick disconnect with flexible hose
5' quick disconnect with flexible hose
Down draft diverter for direct flue
Chassis mount dry chemical fire extinguisher (Class A,B & C) 5 lbs capacity (does not include extinguisher)



# Catering/Outdoor Units



HDO-12-316L



HDB-24-316L



HDC-24-316L



HDG-24-316L

Southbend's Catering/Outdoor units are constructed with 100%\* 316 low carbon stainless steel to withstand the outdoors, no matter what Mother Nature has to offer.

### **Heavy Duty Griddles**

- 1" 316L stainless steel griddle plate
- 30,000 BTU (NAT or LP) burner per 12"
- Integrated 4" high splash guards standard

### **Heavy Duty Charbroilers**

- 20,000 BTU (NAT or LP) stainless steel burner per 6"
- Stainless steel radiants
- Stainless steel rod grates
- Integrated 4" high splash guards standard
- Large capacity grease drawer

### **Heavy Duty Open Top**

- Patented 33,000 BTU NAT (24,000 BTU LP) open top non-clogging burner
- Full width crumb tray
- Porcelain coated cast iron grate

### **Heavy Duty Infrared Broiler**

- 52,000 BTU power induced ceramic burners
- 1,600° F tile temperatures
- High output with compact design

## Gas Models

Description	Model Number	Weight	Dimension WxHxD
18" Countertop Griddle	HDG-18-316L	270 (122)	18"x16.125"x33.75"
24" Countertop Griddle	HDG-24-316L	305 (139)	24"x16.125"x33.75"
18" Countertop Charbroiler 60,000 BTU	HDC-18-316L	200 (91)	12"x16.125"x33.25"
24" Countertop Charbroiler 80,000 BTU	HDC-24-316L	240 (109)	24"x16.125"x33.25"
36" Countertop Charbroiler 120,000 BTU	HDC-36-316L	350 (159)	36"x16.125"x33.25"
12" Open Top (2) 33,000 BTU Burners	HDO-12-316L	165 (75)	12"x11"x33.75"
24" Upright Broiler 52,000 BTU	HDB-24-316L	525 (238)	24"x44"x44"

## Options and Accessories

Options and Accessories
6" Removable Plate Shelf with cutting board - 18" shelf
6" Removable Plate Shelf with cutting board - 24" shelf
316L Stainless Steel Stands 24" HDCS-24-316L 36" HDCS-36-316L 48" HDCS-48-316L 60" HDCS-60-316L 72" HDCS-72-316L
Matching 316L stainless steel work surfaces per 24"

\*excludes manifold, valves, and burners



## Stands

Configuration	Model Number	Size
	HDCS-24	24"
	HDCS-36	36"
	HDCS-48	48"
	HDCS-60	60"
	HDCS-72	72"

(shown with optional casters, factory installed only, not field convertible)

## Options and Accessories

Options and Accessories
<b>Round Rod Grate for Charbroilers</b> 24" 36"
<b>Battery Spark Ignition (For open top and charbroiler units)</b> 12" 24" 36" 48" 60" 72"
Radiant kit to convert briquette to radiant. <i>Includes set of cast iron radiants</i>
Briquette kit to convert radiant to briquette. <i>Includes drip shield, two grates and 5lb. bag of briquettes</i>
Chrome Plated Fish grids
Filler strip for griddles and charbroilers
WOK ring
Lava Rocks



Options and Accessories
<p><b>6" Removable Plate Shelf</b>            SPSS-24 (24" shelf)            SPSS-36 (36" shelf)            SPSS-48 (48" shelf)            SPSS-60 (60" shelf)            SPSS-72 (72" shelf)            Add \$823 LIST for pan cutouts - must specify preferred size of pans to determine quantity of available pan openings.            * SPSS plate shelf not available on HDO units</p>
2-1/2" Legs
Casters for 24", 36" and 48" HDCS stands ( <u>factory installed only</u> )
Casters for 60" and 72" HDCS stands ( <u>factory installed only</u> )
<p><b>2" high insulator base for mounting on refrigerated base (order per unit width)</b>            24" or 36"            48"            60"            72"</p>
<p><b>Grooved griddle plates (requires extended lead times)</b>            Single            Up to 12" of grooving            13" to 24" of grooving            25" to 36" of grooving</p>
<p><b>Chrome plated griddle plates (requires extended lead times)</b>            24"            36"            48"            60"            72"</p>
<p><b>Rear Trough</b>            24"            36"            48"            60"            72"</p>





# TruVection

---

## **THE NEED**

The foodservice industry required a low profile, high performance convection oven design that can be used as a counter top application, stacked or range base while also allowing cook top creativity. The oven would be used in bakeries, restaurants, cafeterias and other facilities to support their demanding high volume food production necessary for profitability.

## **THE CHALLENGE**

Traditional range based gas convection ovens incorporate an atmospheric, open port style burner with a centrifugal blower wheel to circulate heat throughout the cooking cavity. This design requires a longer cold start heating period, slower temperature recovery rates and possible nonuniform baking patterns due to cavity cold zones.

## **THE SOLUTION**

TruVection met the challenge by offering a gas convection oven with a patented high efficiency inshot burner system providing fast cold starts and rapid cavity temperature recovery. Superior uniform baking performance is achieved via oven baffle technology that tempers the heated air when mixed with cooler cavity air.

## **THE PROMISE**

Southbend is dedicated to providing high quality products that meet the increasing demands of commercial cooking equipment. TruVection is unmatched when performance and versatility are preferred.

# TV - Series

## TruVection - Low Profile Convection Oven



TVGS/32SC



TVGS/22SC

w/ optional casters



TVGS/12SC

### Standard Features

- **PATENTED**, high efficiency, inshot burners
- Gas or Electric
- Available in standard depth only
- Single deck TruVection oven is 27-1/4" in height
- Dependent doors with windows
- Energy saving high efficiency glass windows
- Heat keeping dual door seal system
- Oven interior light
- Coved, porcelain interior
- Stay cool heavy-duty door handle
- 1/2 hp two-speed fan motor
- 5-position rack guides and 3 chrome plated oven racks
- Electronic ignition
- Cool down fan mode
- Oven "ready" indicator light
- Can stack up to 3 units
- Platinum modular equipment or Heavy Duty Counterline units can sit on single deck. Overhanging units require an additional low boy cabinet (See page 17 for pricing).

### Gas Models

Description	Model Number	Control Panel	Deck Depth	Dimension WxHxD (on 6" legs)
52,000 BTU Single Deck	TVGS/12SC	standard	standard	36.1"x27.4"x37.5"
104,000 BTU Double Deck	TVGS/22SC	standard	standard	36.1"x48.7"x37.5"
156,000 BTU Triple Deck	TVGS/32SC	standard	standard	36.1"x69.9"x37.5"

### Electric Models

Description	Model Number	Control Panel	Deck Depth	Dimension WxHxD (on 6" legs)
7.5kW Single Deck	TVES/10SC	standard	standard	36.1"x27.4"x37.5"
7.5kW Single Deck - Ventless	TVES/10SC-V	standard	standard	36.1"x27.4"x37.5"
15kW Double Deck	TVES/20SC	standard	standard	36.1"x48.7"x37.5"
15kW Double Deck - Ventless	TVES/20SC-V	standard	standard	36.1"x48.7"x37.5"
22.5kW Triple Deck	TVES/30SC	standard	standard	36.1"x69.9"x37.5"
22.5kW Triple Deck - Ventless	TVES/30SC-V	standard	standard	36.1"x69.9"x37.5"

### Options and Accessories

Options and Accessories
208/240V, 50/60 cycle for gas units (specify voltage and cycle)
High voltage 380V, 415V, or 480V option for electric units (specify voltage and cycle)
12" legs (single deck only)
Stainless steel legs (26" for single deck / 6" for double deck)
6" Casters
4" Casters
Roller bearing rack (only available on the bottom rack)
Marine edge top for 36" unit





# Convection Ovens

---

At Southbend, we pride ourselves on being experts in the food service industry. We know how our customers work and what equipment works for them. Our convection ovens have all the features a busy kitchen needs from the inside out.

The overall measure of any oven is the evenness of cooking. Our convection oven features soft heat mixing zone technology that allows hot air to be mixed with cooler air to produce tempered air, ensuring even baking and cooking.

Our convection oven features patented high efficiency, non-clog inshot burners that utilize a horizontal flame like a jet engine. This burner system delivers up to 90,000 btu's and reduces overall oven height; making it one of the safest ovens in the industry.

We have redesigned our doors with a two stage sealing system with integrated door stop to eliminate seal bending and damage. It also features a thermal isolated door handle; making it cool to the touch for the operator. The door windows feature a larger fully insulated, factory sealed flat panel glass system that is grease vapor resistant for better viewing.

# Platinum Series

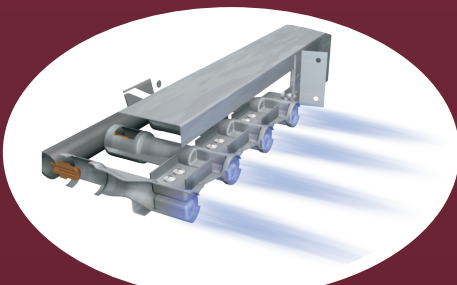

Inshot burners operate with the same concept as a jet engine. Each burner has a single large opening where the air and gas mix. This ensures consistent burn and eliminates the possibility of clogging.



Fully insulated factory sealed, flat panel glass system. Larger panels for better product viewing. Grease vapor resistant in between glass panels.



Two stage door sealing system with integrated door stop to eliminate seal bending/damage. 304 stainless spring steel gasket backed with a steel rope gasket on top and bottom.



A new thermal isolated phenolic/chrome handle and toggle point door closing system.



Gas: PCG50S and PCG100S  
Electric: PCE75S and PCE15S

## NEW TOUCHSCREEN CONTROLS

- Available touch controls on ALL Models
- 3 Cooking Modes allow for more control and consistency in your bake
- Manually set time, temperature, and fan speed in manual mode
- Improve production with rack cooking mode.
- Increase consistency with recipe mode



# Platinum Series



PCG180S/TD  
w/ optional casters



Gas: PCG50S and PCG100S w/ optional casters

PCG90S/TD

## Standard Features

- Available in single or double deck, standard or bakery depth - 50,000, 70,000, 90,000 BTU per oven
  - 60/40 dependent doors or 50/50 independent doors
  - Energy saving high efficiency glass windows
  - Heat keeping dual door seal system
  - Stay cool heavy-duty door handle
  - Stainless steel front, top, sides, and legs
  - Stainless steel rear jacket
  - Oven interior coved corners and two interior lights
  - Electronic ignition and flame failure safety device
  - Single deck: 52" in height with legs, 55" with legs and casters
  - Double deck: 64.8" in height - lowest in the industry\*
  - Unibody with solid frame construction
  - Available in gas
  - Available with a variety of **PATENTED**, interchangeable control panels
  - Slide out control panel for full view servicing
  - Fully front serviceable
- \* Height excludes gas vent

## Options and Accessories

Options and Accessories
Stainless Steel Exterior Bottom
208/240V 50/60 Cycle For Gas Units
High Voltage 380V,415V, or 480V For Electric Units
Export Packaging
Marine edge top - Single Deck Only
12"SS Legs (Single Deck only)
Stainless Steel 6" legs - Double Deck Only
26" Stainless Steel Legs - Single Deck only
Casters - 4" or 6"
Flanged Feet
Stacking Kit With Legs (Double Deck Only)
Stacking Kit With Casters (Double Deck Only)
Stainless Steel Interior (per Deck)
Stainless Steel Rear Jacket (For field mounting)
Extra Oven Rack (specify standard or bakery depth)
Open Pan Guides Under Shelf (Specify Standard or bakery depth)
Downdraft diverter (for use with direct venting on gas models)
Air Insulation Panel
Stainless steel drip pan (per deck)
3/4" quick disconnect with 4' hose
3/4" quick disconnect with 5' hose
3' restraining device - Single Deck only
Stainless steel solid doors



Description	Model Number	Control Panel	Deck Depth	Door Type	Weight	Dimension WxHxD (on legs)
90,000 BTU Single Deck	PCG90B/SD	standard	bakery	Dependent	690 (313)	38"X64.8"X45"
	PCG90B/SI	standard	bakery	Independent	690 (313)	38"X64.8"X45"
	PCG90B/TD	touchscreen	bakery	Dependent	690 (313)	38"X64.8"X45"
	PCG90B/TI	touchscreen	bakery	Independent	690 (313)	38"X64.8"X45"
	PCG90S/SD	standard	standard	Dependent	630 (286)	38"X55"X38.5"
	PCG90S/SI	standard	standard	Independent	630 (286)	38"X55"X38.5"
	PCG90S/TD	touchscreen	standard	Dependent	630 (286)	38"X55"X38.5"
	PCG90S/TI	touchscreen	standard	Independent	630 (286)	38"X55"X38.5"
180,000 BTU Double Deck	PCG180B/SD	standard	bakery	Dependent	1080 (490)	38"X64.8"X45"
	PCG180B/SI	standard	bakery	Independent	1080 (490)	38"X64.8"X45"
	PCG180B/TD	touchscreen	bakery	Dependent	1080 (490)	38"X64.8"X45"
	PCG180B/TI	touchscreen	bakery	Independent	1080 (490)	38"X64.8"X45"
	PCG180S/SD	standard	standard	Dependent	1040 (472)	38"X64.8"X38.5"
	PCG180S/SI	standard	standard	Independent	1040 (472)	38"X64.8"X38.5"
	PCG180S/TD	touchscreen	standard	Dependent	1040 (472)	38"X64.8"X38.5"
	PCG180S/TI	touchscreen	standard	Independent	1040 (472)	38"X64.8"X38.5"
70,000 BTU Single Deck	PCG70B/SD	standard	bakery	Dependent	690 (313)	38"X64.8"X45"
	PCG70B/SI	standard	bakery	Independent	690 (313)	38"X64.8"X45"
	PCG70B/TD	touchscreen	bakery	Dependent	690 (313)	38"X64.8"X45"
	PCG70B/TI	touchscreen	bakery	Independent	690 (313)	38"X64.8"X45"
	PCG70S/SD	standard	standard	Dependent	600 (272)	38"X55"X38.5"
	PCG70S/SI	standard	standard	Independent	600 (272)	38"X55"X38.5"
	PCG70S/TD	touchscreen	standard	Dependent	600 (272)	38"X55"X38.5"
	PCG70S/TI	touchscreen	standard	Independent	600 (272)	38"X55"X38.5"
140,000 BTU Double Deck	PCG140B/SD	standard	bakery	Dependent	1100 (499)	38"X64.8"X45"
	PCG140B/SI	standard	bakery	Independent	1100 (499)	38"X64.8"X45"
	PCG140B/TD	touchscreen	bakery	Dependent	1100 (499)	38"X64.8"X45"
	PCG140B/TI	touchscreen	bakery	Independent	1100 (499)	38"X64.8"X45"
	PCG140S/SD	standard	standard	Dependent	1040 (472)	38"X64.8"X38.5"
	PCG140S/SI	standard	standard	Independent	1040 (472)	38"X64.8"X38.5"
	PCG140S/TD	touchscreen	standard	Dependent	1040 (472)	38"X64.8"X38.5"
	PCG140S/TI	touchscreen	standard	Independent	1040 (472)	38"X64.8"X38.5"
50,000 BTU Single Deck	PCG50B/SD	standard	bakery	Dependent	600 (272)	38"X64.8"X45"
	PCG50B/SI	standard	bakery	Independent	600 (272)	38"X64.8"X45"
	PCG50B/TD	touchscreen	bakery	Dependent	600 (272)	38"X64.8"X45"
	PCG50B/TI	touchscreen	bakery	Independent	600 (272)	38"X64.8"X45"
	PCG50S/SD	standard	standard	Dependent	600 (272)	38"X55"X38.5"
	PCG50S/SI	standard	standard	Independent	600 (272)	38"X55"X38.5"
	PCG50S/TD	touchscreen	standard	Dependent	600 (272)	38"X55"X38.5"
	PCG50S/TI	touchscreen	standard	Independent	600 (272)	38"X55"X38.5"
100,000 BTU Double Deck	PCG100B/SD	standard	bakery	Dependent	1100 (499)	38"X64.8"X45"
	PCG100B/SI	standard	bakery	Independent	1100 (499)	38"X64.8"X45"
	PCG100B/TD	touchscreen	bakery	Dependent	1100 (499)	38"X64.8"X45"
	PCG100B/TI	touchscreen	bakery	Independent	1100 (499)	38"X64.8"X45"
	PCG100S/SD	standard	standard	Dependent	1100 (499)	38"X64.8"X38.5"
	PCG100S/SI	standard	standard	Independent	1100 (499)	38"X64.8"X38.5"
	PCG100S/TD	touchscreen	standard	Dependent	1100 (499)	38"X64.8"X38.5"
	PCG100S/TI	touchscreen	standard	Independent	1100 (499)	38"X64.8"X38.5"



# Platinum Series



PCE22S/SD  
w/ optional casters



PCE75S/SD  
w/ optional casters

### Standard Features

- Available in single or double deck, standard or bakery depth - 7.5, 11, 15, 22 KW per oven
  - 60/40 dependent doors or 50/50 independent doors
  - Energy saving high efficiency glass windows
  - Heat keeping dual door seal system
  - Stay cool heavy-duty door handle
  - Stainless steel front, top, sides, and legs
  - Oven interior coved corners and two interior lights
  - Electronic ignition and flame failure safety device
  - Single deck: 52" in height with legs, 55" with legs and casters
  - Double deck: 64.8" in height - lowest in the industry\*
  - Unibody with solid frame construction
  - Available in electric
  - Available with a variety of **PATENTED**, interchangeable control panels
  - Slide out control panel for full view servicing
  - Fully front serviceable
- \* Height excludes gas vent

Electric: PCE75S and PCE15S

### Options and Accessories

Options and Accessories
Stainless Steel Exterior Bottom
208/240V 50/60 Cycle For Gas Units
High Voltage 380V,415V, or 480V For Electric Units
Export Packing
Marine edge top - Single Deck Only
12"SS Legs (Single Deck only)
Stainless Steel 6" legs - Double Deck Only
26" Stainless Steel Legs - Single Deck only
Casters - 4" or 6"
Flanged Feet
Stacking Kit With Legs (Double Deck Only)
Stacking Kit With Casters (Double Deck Only)
Stainless Steel Interior (per Deck)
Stainless Steel Rear Jacket (For field mounting)
Extra Oven Rack (specify standard or bakery depth)
Open Pan Guides Under Shelf (Specify Standard or bakery depth)
Downdraft diverter (for use with direct venting on gas models)
Air Insulation Panel
Stainless steel drip pan (per deck)
3/4" quick disconnect with 4' hose
3/4" quick disconnect with 5' hose
3' restraining device - Single Deck only
Stainless steel solid doors

\* All double deck units shipped stacked and interpiped unless otherwise requested.



## Electric Models

Description	Model Number	Control Panel	Deck Depth	Door Type	Weight	Dimension WxHxD (on legs)
Electric - 11 kW Single Deck	PCE11B/SD	standard	bakery	Dependent	690 (313)	38"X64.8"X45"
	PCE11B/SI	standard	bakery	Independent	690 (313)	38"X64.8"X45"
	PCE11B/TD	touchscreen	bakery	Dependent	690 (313)	38"X64.8"X45"
	PCE11B/TI	touchscreen	bakery	Independent	690 (313)	38"X64.8"X45"
	PCE11S/SD	standard	standard	Dependent	630 (286)	38"X55"X38.5"
	PCE11S/SI	standard	standard	Independent	630 (286)	38"X55"X38.5"
	PCE11S/TD	touchscreen	standard	Dependent	630 (286)	38"X55"X38.5"
	PCE11S/TI	touchscreen	standard	Independent	630 (286)	38"X55"X38.5"
Electric - 22kW Double Deck	PCE22B/SD	standard	bakery	Dependent	1080 (490)	38"X64.8"X45"
	PCE22B/SI	standard	bakery	Independent	1080 (490)	38"X64.8"X45"
	PCE22B/TD	touchscreen	bakery	Dependent	1080 (490)	38"X64.8"X45"
	PCE22B/TI	touchscreen	bakery	Independent	1080 (490)	38"X64.8"X45"
	PCE22S/SD	standard	standard	Dependent	1040 (472)	38"X64.8"X38.5"
	PCE22S/SI	standard	standard	Independent	1040 (472)	38"X64.8"X38.5"
	PCE22S/TD	touchscreen	standard	Dependent	1040 (472)	38"X64.8"X38.5"
	PCE22S/TI	touchscreen	standard	Independent	1040 (472)	38"X64.8"X38.5"
Electric - 7.5 kW Single Deck	PCE75B/SD	standard	bakery	Dependent	690 (313)	38"X64.8"X45"
	PCE75B/SI	standard	bakery	Independent	690 (313)	38"X64.8"X45"
	PCE75B/TD	touchscreen	bakery	Dependent	690 (313)	38"X64.8"X45"
	PCE75B/TI	touchscreen	bakery	Independent	690 (313)	38"X64.8"X45"
	PCE75S/SD	standard	standard	Dependent	600 (272)	38"X55"X38.5"
	PCE75S/SI	standard	standard	Independent	600 (272)	38"X55"X38.5"
	PCE75S/TD	touchscreen	standard	Dependent	600 (272)	38"X55"X38.5"
	PCE75S/TI	touchscreen	standard	Independent	600 (272)	38"X55"X38.5"
Electric - 15kW Double Deck	PCE15B/SD	standard	bakery	Dependent	1100 (499)	38"X64.8"X45"
	PCE15B/SI	standard	bakery	Independent	1100 (499)	38"X64.8"X45"
	PCE15B/TD	touchscreen	bakery	Dependent	1100 (499)	38"X64.8"X45"
	PCE15B/TI	touchscreen	bakery	Independent	1100 (499)	38"X64.8"X45"
	PCE15S/SD	standard	standard	Dependent	1040 (472)	38"X64.8"X38.5"
	PCE15S/SI	standard	standard	Independent	1040 (472)	38"X64.8"X38.5"
	PCE15S/TD	touchscreen	standard	Dependent	1040 (472)	38"X64.8"X38.5"
	PCE15S/TI	touchscreen	standard	Independent	1040 (472)	38"X64.8"X38.5"

## Competitive Information

Standard Features	Southbend PCE11S/TD	Garland MCO-ES-10-S	Vulcan VC4ED
Kilowatts	11 kW	10.4 kW	12.5 kW
Product warranty	1 years parts and labor	2 years parts 1 year labor	1 year parts and labor
<b>PATENTED</b> , Interchangeable control panels	Yes	No	No
Fan speeds	2	2	2
Fan horsepower	1/2 HP	3/4 HP	1/2 HP
Windows in doors	Both	Both	Both
Door type	60/40	60/40	50/50
Dependent doors	Yes	Yes	No
Door Warranty	5 years (parts only after 1 year)	5 years	1 year
Optional stainless steel doors	No Charge	No Charge	No Charge
Interior lights	Yes	Yes	Yes
Height of double oven on 6" legs	64.8"	71.75"	70"
Temperature Control Range (Fahrenheit)	140°-500°	150°-500°	150°-500°
Stainless steel front, sides, and top	Yes	Yes	Yes
Legs	26 in S/S	25.5 in S/S	23.75 in Painted



# VENTLESS Platinum Series



## Standard Features

- Available in single or double deck standard depth - 7.5 or 11 KW per oven cavity
- 60/40 dependent doors or 50/50 independent doors
- Energy saving high efficiency glass windows
- Heat keeping dual door seal system
- Stay cool heavy-duty door handle
- Stainless steel front, top, and sides
- Electronic ignition and flame failure safety device
- Single deck: 52" in height with legs, 55" with legs and casters
- Double deck: 64.8" in height. - lowest in the industry\*
- Unibody solid frame construction
- Available in electric only
- Available with standard control panel or touchscreen controls
- Slide out control panel for full view servicing
- Fully front serviceable

## Options and Accessories

Options and Accessories
Stainless Steel Exterior Bottom
208/240V 50/60 Cycle For Gas Units
High Voltage 380V,415V, or 480V For Electric Units
Export Packging
Marine edge top - Single Deck Only
12"SS Legs (Single Deck only)
Stainless Steel 6" legs - Double Deck Only
26" Stainless Steel Legs - Single Deck only
Casters - 4" or 6"
Flanged Feet
Stacking Kit With Legs (Double Deck Only)
Stacking Kit With Casters (Double Deck Only)
Stainless Steel Interior (per Deck)
Stainless Steel Rear Jacket (For field mounting)
Extra Oven Rack (specify standard or bakery depth)
Open Pan Guides Under Shelf (Specify Standard or bakery depth)
Downdraft diverter (for use with direct venting on gas models)
Air Insulation Panel
Stainless steel drip pan (per deck)
3/4" quick disconnect with 4' hose
3/4" quick disconnect with 5' hose
3' restraining device - Single Deck only
Stainless steel solid doors



Description	Model Number	Control Panel	Deck Depth	Door Type	Weight	Dimension WxHxD (on legs)
Electric - 11 kW Single Deck	PCE11B/SD-V	standard	bakery	Dependent	690 (313)	38"X64.8"X45"
	PCE11B/SI-V	standard	bakery	Independent	690 (313)	38"X64.8"X45"
	PCE11B/TD-V	touchscreen	bakery	Dependent	690 (313)	38"X64.8"X45"
	PCE11B/TI-V	touchscreen	bakery	Independent	690 (313)	38"X64.8"X45"
	PCE11S/SD-V	standard	standard	Dependent	630 (286)	38"X55"X38.5"
	PCE11S/SI-V	standard	standard	Independent	630 (286)	38"X55"X38.5"
	PCE11S/TD-V	touchscreen	standard	Dependent	630 (286)	38"X55"X38.5"
Electric - 22kW Double Deck	PCE22B/SD-V	standard	bakery	Dependent	1080 (490)	38"X64.8"X45"
	PCE22B/SI-V	standard	bakery	Independent	1080 (490)	38"X64.8"X45"
	PCE22B/TD-V	touchscreen	bakery	Dependent	1080 (490)	38"X64.8"X45"
	PCE22B/TI-V	touchscreen	bakery	Independent	1080 (490)	38"X64.8"X45"
	PCE22S/SD-V	standard	standard	Dependent	1040 (472)	38"X64.8"X38.5"
	PCE22S/SI-V	standard	standard	Independent	1040 (472)	38"X64.8"X38.5"
	PCE22S/TD-V	touchscreen	standard	Dependent	1040 (472)	38"X64.8"X38.5"
Electric - 7.5 kW Single Deck	PCE75B/SD-V	standard	bakery	Dependent	690 (313)	38"X64.8"X45"
	PCE75B/SI-V	standard	bakery	Independent	690 (313)	38"X64.8"X45"
	PCE75B/TD-V	touchscreen	bakery	Dependent	690 (313)	38"X64.8"X45"
	PCE75B/TI-V	touchscreen	bakery	Independent	690 (313)	38"X64.8"X45"
	PCE75S/SD-V	standard	standard	Dependent	600 (272)	38"X55"X38.5"
	PCE75S/SI-V	standard	standard	Independent	600 (272)	38"X55"X38.5"
	PCE75S/TD-V	touchscreen	standard	Dependent	600 (272)	38"X55"X38.5"
Electric - 15kW Double Deck	PCE15B/SD-V	standard	bakery	Dependent	1100 (499)	38"X64.8"X45"
	PCE15B/SI-V	standard	bakery	Independent	1100 (499)	38"X64.8"X45"
	PCE15B/TD-V	touchscreen	bakery	Dependent	1100 (499)	38"X64.8"X45"
	PCE15B/TI-V	touchscreen	bakery	Independent	1100 (499)	38"X64.8"X45"
	PCE15S/SD-V	standard	standard	Dependent	1040 (472)	38"X64.8"X38.5"
	PCE15S/SI-V	standard	standard	Independent	1040 (472)	38"X64.8"X38.5"
	PCE15S/TD-V	touchscreen	standard	Dependent	1040 (472)	38"X64.8"X38.5"
PCE15S/TI-V	touchscreen	standard	Independent	1040 (472)	38"X64.8"X38.5"	

Patented interchangeable control panels and upgrades



**SC - Standard Controls**  
 140°F to 500°F solid state thermostat and 60 minute electrical cook timer (general use).



**TC - Digital Touch Controls**  
 4.3 inch screen boasts a bright easy-to-read full-color display, capacitive touch controls, and a user friendly menu system.

- Manually set time, temperature, and fan speed in manual mode.
- Improve production with rack cooking mode.
- Increase consistency with recipe mode.



# Platinum Series Half Size



## Standard Features

- Stainless steel front, top, sides and legs
- Single deck: 52" in height with legs, 55" with legs and casters
- Double deck: 64" in height
- Unibody with solid frame construction
- Available gas or electric
- Available with a variety of **PATENTED**, interchangeable control panels
- Fully front serviceable
- **New! Optional Touchscreen Controls** with 3 cooking modes - manual, recipe, or rack modes.

## Competitive Information

Standard Features	Southbend EH	Duke 59-E3	Garland MCO	Montague EK8	Vulcan ECO
KW Rating	7.5	8.0	5.6	7.9	5.5
<b>PATENTED</b> , Interchangeable control panels	Yes	No	No	No	No
Two-speed fan	Yes	Yes	Yes	Yes	Yes
Fan horsepower	1/3 HP	1/2 HP	1/3 HP	1/3 HP	1/3 HP
Window in door	Yes	Yes	Yes	Yes	Yes
Distance for door opening	18.25"	19.44"	20"	19.25"	19.38"
100% front serviceable	Yes	Yes	No	No	No
Electronic Ignition	Yes	Yes	Yes	Yes	Yes
Height of single oven (with 4" legs)	33"	30"	29.75"	29.38"	30.63"
Height of double oven (with 6" legs)	64"	58"	57.5"	60.75"	57.63"
Depth with door handle	26.75"	29.25"	29.75"	30.375"	28.5"
140°F to 500°F temp. control	Yes	No	No	No	No
Stainless steel front, sides, and top	Yes	Yes	Yes	Yes	Yes
Can be operated without legs	Yes	Yes	Yes	Yes	Yes



## Gas Models

Description	Model Number	Control Panel	Deck Depth	Weight	Dimension WxHxD (on legs)
Gas - Half Size 30,000 BTU Single Deck	PCHG30S/S	standard	standard	420 (191)	30"X33"X26.8"
	PCHG30S/T	touchscreen	standard	420 (191)	30"X33"X26.8"
Gas - Half Size 60,000 BTU Double Deck	PCHG60S/S	standard	standard	850 (386)	30"X64"X26.8"
	PCHG60S/T	touchscreen	standard	850 (386)	30"X64"X26.8"

## Electric Models

Description	Model Number	Control Panel	Deck Depth	Weight	Dimension WxHxD (on legs)
Electric - Half Size 7.5 kW Single Deck	PCHE75S/S	standard	standard	420 (191)	30"X33"X26.8"
	PCHE75S/T	touchscreen	standard	420 (191)	30"X33"X26.8"
Electric - Half Size 15 kW Double Deck	PCHE15S/S	standard	standard	850 (386)	30"X64"X26.8"
	PCHE15S/T	touchscreen	standard	850 (386)	30"X64"X26.8"

## Ventless Models

Description	Model Number	Control Panel	Deck Depth	Weight	Dimension WxHxD (on legs)
Electric - Half Size 7.5 kW Single Deck	PCHE75S/S-V	standard	standard	420 (191)	30"X33"X26.8"
	PCHE75S/T-V	touchscreen	standard	420 (191)	30"X33"X26.8"
Electric - Half Size 15 kW Double Deck	PCHE15S/S-V	standard	standard	850 (386)	30"X64"X26.8"
	PCHE15S/T-V	touchscreen	standard	850 (386)	30"X64"X26.8"

## Options and Accessories

Options and Accessories
Stainless steel solid doors
High voltage 380V, 415V, or 480V option for Electric units (specify voltage and cycle)
Export packaging
Marine edge top
26" stainless steel legs
26" stainless steel legs with casters
26" stainless steel legs with flanged feet
Stainless steel legs with rack pan guide kit
Casters
Flanged feet
12" stainless steel legs (single deck only)
6" stainless steel legs
Extra oven rack
Stainless steel drip pan

\* All double deck units shipped stacked and interpipied unless otherwise requested.



# Platinum PRO Series

Introducing the Southbend Platinum PRO Series Convection Ovens—the next evolution in commercial cooking. As the industry’s first convection ovens to feature both wired and wireless probe technology, the Platinum PRO Series gives chefs unparalleled control and precision. Whether cooking by time or internal temperature, these ovens deliver consistent, reliable results every time. With advanced PROgrammable Controls, smart PRObe Cooking options, and PROfessional Results you can count on, Southbend is redefining what performance looks like in the modern kitchen.

## Patented interchangeable control panels and upgrades



**Standard Controls**  
Have two wired interior probes per oven cavity that allows for cooking by time or by temperature



**Digital Touch Controls**  
Have two wired interior probes per oven cavity that allows for cooking by time or by temperature.

Can upgrade to two wireless probes per oven cavity to add versatility, able to connect up to 30 feet away.

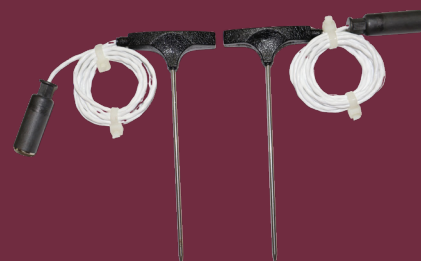

WIRED PROBES



WIRELESS PROBES

## PROgrammable Controls

The Platinum PRO Series features state-of-the-art touchscreen controls that bring precision and efficiency to the forefront of your kitchen. These intuitive controls allow users to create, save, and recall custom cooking recipes with ease—streamlining operations and eliminating guesswork during busy service. Whether you're preparing the same item day after day or switching between seasonal menus, programmable settings ensure repeatable results with minimal training.

With the ability to cook by time, temperature, or a combination of both, the PRO Series adapts to your kitchen's specific needs. From low-and-slow baking to high-volume roasting, the flexibility built into the control system empowers chefs and kitchen staff to execute with confidence. These controls not only improve consistency but also reduce labor and prep time, making them a powerful asset for both experienced and new operators.

## PRObe Cooking

The Platinum PRO Series breaks new ground as the first convection ovens in the industry to offer both wired and wireless probe cooking technology. This revolutionary feature gives operators complete control over internal product temperature, allowing for precise doneness across a wide variety of menu items. Whether you're monitoring a roast or a delicate protein, the real-time temperature feedback ensures perfect results—without constant checking or overcooking.

The wireless probe adds a new level of convenience and flexibility, eliminating cord clutter and allowing for smoother workflows in tight or high-traffic kitchens. Both probe types integrate seamlessly with the oven's programmable controls, so you can automatically stop cooking or initiate holding cycles when the target temperature is reached. It's a smarter, safer, and more efficient way to cook—giving you peace of mind and better food quality.

## PROfessional Results

In high-volume, high-expectation environments, consistency is everything—and that's exactly what the Platinum PRO Series delivers. These ovens are engineered for performance, with powerful convection fans, even heat distribution, and fast recovery times to maintain ideal cooking conditions. Whether baking, roasting, or reheating, you'll get uniform results across every rack, every time.

But professional results go beyond performance—they're also about confidence, presentation, and reputation. The Platinum PRO Series helps you uphold the highest culinary standards, no matter your operation size. From restaurants and hotels to schools and healthcare facilities, these ovens produce food that looks better, tastes better, and meets the expectations of even the most discerning guests.

# Platinum PRO Series



PCG180S/TD-PRO  
w/ optional casters



Gas: PCG50S and PCG100S

PCG90S/TD-PRO  
w/ optional casters

## Standard Features

- Available in single or double deck, standard or bakery depth - 50,000, 70,000, 90,000 BTU per oven
- 60/40 dependent doors or 50/50 Independent Doors
- Energy saving high efficiency glass windows
- Heat keeping dual door seal system
- Stay cool heavy-duty door handle
- Stainless steel front, top, sides, and legs
- Stainless steel rear jacket
- Oven interior coved corners and two interior lights
- Electronic ignition and flame failure safety device
- Single deck: 52" in height with legs, 55" with legs and casters
- Double deck: 64.8" in height - lowest in the industry\*
- Unibody with solid frame construction
- Available in gas
- Available with a variety of **PATENTED**, interchangeable control panels
- Wired Interior Probes for cooking by time or temperature

## Options and Accessories

Options and Accessories
Stainless Steel Exterior Bottom
208/240V 50/60 Cycle For Gas Units
High Voltage 380V,415V, or 480V For Electric Units
Export Packaging
Marine edge top - Single Deck Only
12"SS Legs (Single Deck only)
Stainless Steel 6" legs - Double Deck Only
26" Stainless Steel Legs - Single Deck only
Casters - 4" or 6"
Flanged Feet
Stacking Kit With Legs (Double Deck Only)
Stacking Kit With Casters (Double Deck Only)
Stainless Steel Interior (per Deck)
Stainless Steel Rear Jacket (For field mounting)
Extra Oven Rack (specify standard or bakery depth)
Open Pan Guides Under Shelf (Specify Standard or bakery depth)
Downdraft diverter (for use with direct venting on gas models)
Air Insulation Panel
Stainless steel drip pan (per deck)
3/4" quick disconnect with 4' hose
3/4" quick disconnect with 5' hose
3' restraining device - Single Deck only
Stainless steel solid doors
Wireless Probes (available for Touchscreen ONLY)



Description	Model Number	Control Panel	Deck Depth	Door Type	Weight	Dimension WxHxD (on legs)
90,000 BTU Single Deck	PCG90B/SD-PRO	standard	bakery	Dependent	690 (313)	38"X64.8"X45"
	PCG90B/SI-PRO	standard	bakery	Independent	690 (313)	38"X64.8"X45"
	PCG90B/TD-PRO	touchscreen	bakery	Dependent	690 (313)	38"X64.8"X45"
	PCG90B/TI-PRO	touchscreen	bakery	Independent	690 (313)	38"X64.8"X45"
	PCG90S/SD-PRO	standard	standard	Dependent	630 (286)	38"X55"X38.5"
	PCG90S/SI-PRO	standard	standard	Independent	630 (286)	38"X55"X38.5"
	PCG90S/TD-PRO	touchscreen	standard	Dependent	630 (286)	38"X55"X38.5"
	PCG90S/TI-PRO	touchscreen	standard	Independent	630 (286)	38"X55"X38.5"
180,000 BTU Double Deck	PCG180B/SD-PRO	standard	bakery	Dependent	1080 (490)	38"X64.8"X45"
	PCG180B/SI-PRO	standard	bakery	Independent	1080 (490)	38"X64.8"X45"
	PCG180B/TD-PRO	touchscreen	bakery	Dependent	1080 (490)	38"X64.8"X45"
	PCG180B/TI-PRO	touchscreen	bakery	Independent	1080 (490)	38"X64.8"X45"
	PCG180S/SD-PRO	standard	standard	Dependent	1040 (472)	38"X64.8"X38.5"
	PCG180S/SI-PRO	standard	standard	Independent	1040 (472)	38"X64.8"X38.5"
	PCG180S/TD-PRO	touchscreen	standard	Dependent	1040 (472)	38"X64.8"X38.5"
	PCG180S/TI-PRO	touchscreen	standard	Independent	1040 (472)	38"X64.8"X38.5"
70,000 BTU Single Deck	PCG70B/SD-PRO	standard	bakery	Dependent	690 (313)	38"X64.8"X45"
	PCG70B/SI-PRO	standard	bakery	Independent	690 (313)	38"X64.8"X45"
	PCG70B/TD-PRO	touchscreen	bakery	Dependent	690 (313)	38"X64.8"X45"
	PCG70B/TI-PRO	touchscreen	bakery	Independent	690 (313)	38"X64.8"X45"
	PCG70S/SD-PRO	standard	standard	Dependent	600 (272)	38"X55"X38.5"
	PCG70S/SI-PRO	standard	standard	Independent	600 (272)	38"X55"X38.5"
	PCG70S/TD-PRO	touchscreen	standard	Dependent	600 (272)	38"X55"X38.5"
	PCG70S/TI-PRO	touchscreen	standard	Independent	600 (272)	38"X55"X38.5"
140,000 BTU Double Deck	PCG140B/SD-PRO	standard	bakery	Dependent	1100 (499)	38"X64.8"X45"
	PCG140B/SI-PRO	standard	bakery	Independent	1100 (499)	38"X64.8"X45"
	PCG140B/TD-PRO	touchscreen	bakery	Dependent	1100 (499)	38"X64.8"X45"
	PCG140B/TI-PRO	touchscreen	bakery	Independent	1100 (499)	38"X64.8"X45"
	PCG140S/SD-PRO	standard	standard	Dependent	1040 (472)	38"X64.8"X38.5"
	PCG140S/SI-PRO	standard	standard	Independent	1040 (472)	38"X64.8"X38.5"
	PCG140S/TD-PRO	touchscreen	standard	Dependent	1040 (472)	38"X64.8"X38.5"
	PCG140S/TI-PRO	touchscreen	standard	Independent	1040 (472)	38"X64.8"X38.5"
50,000 BTU Single Deck	PCG50B/SD-PRO	standard	bakery	Dependent	600 (272)	38"X64.8"X45"
	PCG50B/SI-PRO	standard	bakery	Independent	600 (272)	38"X64.8"X45"
	PCG50B/TD-PRO	touchscreen	bakery	Dependent	600 (272)	38"X64.8"X45"
	PCG50B/TI-PRO	touchscreen	bakery	Independent	600 (272)	38"X64.8"X45"
	PCG50S/SD-PRO	standard	standard	Dependent	600 (272)	38"X55"X38.5"
	PCG50S/SI-PRO	standard	standard	Independent	600 (272)	38"X55"X38.5"
	PCG50S/TD-PRO	touchscreen	standard	Dependent	600 (272)	38"X55"X38.5"
	PCG50S/TI-PRO	touchscreen	standard	Independent	600 (272)	38"X55"X38.5"
100,000 BTU Double Deck	PCG100B/SD-PRO	standard	bakery	Dependent	1100 (499)	38"X64.8"X45"
	PCG100B/SI-PRO	standard	bakery	Independent	1100 (499)	38"X64.8"X45"
	PCG100B/TD-PRO	touchscreen	bakery	Dependent	1100 (499)	38"X64.8"X45"
	PCG100B/TI-PRO	touchscreen	bakery	Independent	1100 (499)	38"X64.8"X45"
	PCG100S/SD-PRO	standard	standard	Dependent	1100 (499)	38"X64.8"X38.5"
	PCG100S/SI-PRO	standard	standard	Independent	1100 (499)	38"X64.8"X38.5"
	PCG100S/TD-PRO	touchscreen	standard	Dependent	1100 (499)	38"X64.8"X38.5"
	PCG100S/TI-PRO	touchscreen	standard	Independent	1100 (499)	38"X64.8"X38.5"

\* All double deck units shipped stacked and interped unless otherwise requested.



# Platinum PRO Series



PCE22S/SD  
w/ optional casters



PCE75S/SD  
w/ optional casters

## Standard Features

- Available in single or double deck, standard or bakery depth - 7.5, 11, 15, 22 KW per oven
- 60/40 dependent doors or 50/50 independent doors
- Energy saving high efficiency glass windows
- Heat keeping dual door seal system
- Stay cool heavy-duty door handle
- Stainless steel front, top, sides, and legs
- Oven interior coved corners and two interior lights
- Electronic ignition and flame failure safety device
- Single deck: 52" in height with legs, 55" with legs and casters
- Double deck: 64.8" in height - lowest in the industry\*
- Unibody with solid frame construction
- Available in electric
- Available with a variety of **PATENTED**, interchangeable control panels
- Wired Interior Probes for cooking by time or temperature
- Slide out control panel for full view servicing
- Fully front serviceable
- \* Height excludes gas vent

Electric: PCE75S and PCE15S

## Options and Accessories

Options and Accessories
Stainless Steel Exterior Bottom
208/240V 50/60 Cycle For Gas Units
High Voltage 380V,415V, or 480V For Electric Units
Export Packaging
Marine edge top - Single Deck Only
12"SS Legs (Single Deck only)
Stainless Steel 6" legs - Double Deck Only
26" Stainless Steel Legs - Single Deck only
Casters - 4" or 6"
Flanged Feet
Stacking Kit With Legs (Double Deck Only)
Stacking Kit With Casters (Double Deck Only)
Stainless Steel Interior (per Deck)
Stainless Steel Rear Jacket (For field mounting)
Extra Oven Rack (specify standard or bakery depth)
Open Pan Guides Under Shelf (Specify Standard or bakery depth)
Downdraft diverter (for use with direct venting on gas models)
Air Insulation Panel
Stainless steel drip pan (per deck)
3/4" quick disconnect with 4' hose
3/4" quick disconnect with 5' hose
3' restraining device - Single Deck only
Stainless steel solid doors
Wireless Probes (available for Touchscreen ONLY)

\* All double deck units shipped stacked and interpiped unless otherwise requested.



## Electric Models

Description	Model Number	Control Panel	Deck Depth	Door Type	Weight	Dimension WxHxD (on legs)
Electric - 11 kW Single Deck	PCE11B/SD-PRO	standard	bakery	Dependent	690 (313)	38"X64.8"X45"
	PCE11B/SI-PRO	standard	bakery	Independent	690 (313)	38"X64.8"X45"
	PCE11B/TD-PRO	touchscreen	bakery	Dependent	690 (313)	38"X64.8"X45"
	PCE11B/TI-PRO	touchscreen	bakery	Independent	690 (313)	38"X64.8"X45"
	PCE11S/SD-PRO	standard	standard	Dependent	630 (286)	38"X55"X38.5"
	PCE11S/SI-PRO	standard	standard	Independent	630 (286)	38"X55"X38.5"
	PCE11S/TD-PRO	touchscreen	standard	Dependent	630 (286)	38"X55"X38.5"
	PCE11S/TI-PRO	touchscreen	standard	Independent	630 (286)	38"X55"X38.5"
Electric - 22kW Double Deck	PCE22B/SD-PRO	standard	bakery	Dependent	1080 (490)	38"X64.8"X45"
	PCE22B/SI-PRO	standard	bakery	Independent	1080 (490)	38"X64.8"X45"
	PCE22B/TD-PRO	touchscreen	bakery	Dependent	1080 (490)	38"X64.8"X45"
	PCE22B/TI-PRO	touchscreen	bakery	Independent	1080 (490)	38"X64.8"X45"
	PCE22S/SD-PRO	standard	standard	Dependent	1040 (472)	38"X64.8"X38.5"
	PCE22S/SI-PRO	standard	standard	Independent	1040 (472)	38"X64.8"X38.5"
	PCE22S/TD-PRO	touchscreen	standard	Dependent	1040 (472)	38"X64.8"X38.5"
	PCE22S/TI-PRO	touchscreen	standard	Independent	1040 (472)	38"X64.8"X38.5"
Electric - 7.5 kW Single Deck	PCE75B/SD-PRO	standard	bakery	Dependent	690 (313)	38"X64.8"X45"
	PCE75B/SI-PRO	standard	bakery	Independent	690 (313)	38"X64.8"X45"
	PCE75B/TD-PRO	touchscreen	bakery	Dependent	690 (313)	38"X64.8"X45"
	PCE75B/TI-PRO	touchscreen	bakery	Independent	690 (313)	38"X64.8"X45"
	PCE75S/SD-PRO	standard	standard	Dependent	600 (272)	38"X55"X38.5"
	PCE75S/SI-PRO	standard	standard	Independent	600 (272)	38"X55"X38.5"
	PCE75S/TD-PRO	touchscreen	standard	Dependent	600 (272)	38"X55"X38.5"
	PCE75S/TI-PRO	touchscreen	standard	Independent	600 (272)	38"X55"X38.5"
Electric - 15kW Double Deck	PCE15B/SD-PRO	standard	bakery	Dependent	1100 (499)	38"X64.8"X45"
	PCE15B/SI-PRO	standard	bakery	Independent	1100 (499)	38"X64.8"X45"
	PCE15B/TD-PRO	touchscreen	bakery	Dependent	1100 (499)	38"X64.8"X45"
	PCE15B/TI-PRO	touchscreen	bakery	Independent	1100 (499)	38"X64.8"X45"
	PCE15S/SD-PRO	standard	standard	Dependent	1040 (472)	38"X64.8"X38.5"
	PCE15S/SI-PRO	standard	standard	Independent	1040 (472)	38"X64.8"X38.5"
	PCE15S/TD-PRO	touchscreen	standard	Dependent	1040 (472)	38"X64.8"X38.5"
	PCE15S/TI-PRO	touchscreen	standard	Independent	1040 (472)	38"X64.8"X38.5"



# VENTLESS Platinum PRO Series



PCE22S/SD-V  
w/ optional casters

PCE75S/SD-V  
w/ optional casters

## Standard Features

- Available in single or double deck standard depth - 7.5 or 11 KW per oven cavity
- 60/40 dependent doors or 50/50 independent doors
- Energy saving high efficiency glass windows
- Heat keeping dual door seal system
- Stay cool heavy-duty door handle
- Stainless steel front, top, and sides
- Electronic ignition and flame failure safety device
- Single deck: 52" in height with legs, 55" with legs and casters
- Double deck: 64.8" in height. - lowest in the industry\*
- Unibody solid frame construction
- Available in electric only
- Available with standard control panel or touchscreen controls
- Wired Interior Probes for cooking by time or temperature
- Fully front serviceable

## Options and Accessories

Options and Accessories
Stainless Steel Exterior Bottom
208/240V 50/60 Cycle For Gas Units
High Voltage 380V,415V, or 480V For Electric Units
Export Packaging
Marine edge top - Single Deck Only
12"SS Legs (Single Deck only)
Stainless Steel 6" legs - Double Deck Only
26" Stainless Steel Legs - Single Deck only
Casters - 4" or 6"
Flanged Feet
Stacking Kit With Legs (Double Deck Only)
Stacking Kit With Casters (Double Deck Only)
Stainless Steel Interior (per Deck)
Stainless Steel Rear Jacket (For field mounting)
Extra Oven Rack (specify standard or bakery depth)
Open Pan Guides Under Shelf (Specify Standard or bakery depth)
Downdraft diverter (for use with direct venting on gas models)
Air Insulation Panel
Stainless steel drip pan (per deck)
3/4" quick disconnect with 4' hose
3/4" quick disconnect with 5' hose
3' restraining device - Single Deck only
Stainless steel solid doors
Wireless Probes (available for Touchscreen ONLY)



Description	Model Number	Control Panel	Deck Depth	Door Type	Weight	Dimension WxHxD (on legs)
Electric - 11 kW Single Deck	PCE11B/SD-V-PRO	standard	bakery	Dependent	690 (313)	38"X64.8"X45"
	PCE11B/SI-V-PRO	standard	bakery	Independent	690 (313)	38"X64.8"X45"
	PCE11B/TD-V-PRO	touchscreen	bakery	Dependent	690 (313)	38"X64.8"X45"
	PCE11B/TI-V-PRO	touchscreen	bakery	Independent	690 (313)	38"X64.8"X45"
	PCE11S/SD-V-PRO	standard	standard	Dependent	630 (286)	38"X55"X38.5"
	PCE11S/SI-V-PRO	standard	standard	Independent	630 (286)	38"X55"X38.5"
	PCE11S/TD-V-PRO	touchscreen	standard	Dependent	630 (286)	38"X55"X38.5"
Electric - 22kW Double Deck	PCE22B/SD-V-PRO	standard	bakery	Dependent	1080 (490)	38"X64.8"X45"
	PCE22B/SI-V-PRO	standard	bakery	Independent	1080 (490)	38"X64.8"X45"
	PCE22B/TD-V-PRO	touchscreen	bakery	Dependent	1080 (490)	38"X64.8"X45"
	PCE22B/TI-V-PRO	touchscreen	bakery	Independent	1080 (490)	38"X64.8"X45"
	PCE22S/SD-V-PRO	standard	standard	Dependent	1040 (472)	38"X64.8"X38.5"
	PCE22S/SI-V-PRO	standard	standard	Independent	1040 (472)	38"X64.8"X38.5"
	PCE22S/TD-V-PRO	touchscreen	standard	Dependent	1040 (472)	38"X64.8"X38.5"
Electric - 7.5 kW Single Deck	PCE75B/SD-V-PRO	standard	bakery	Dependent	690 (313)	38"X64.8"X45"
	PCE75B/SI-V-PRO	standard	bakery	Independent	690 (313)	38"X64.8"X45"
	PCE75B/TD-V-PRO	touchscreen	bakery	Dependent	690 (313)	38"X64.8"X45"
	PCE75B/TI-V-PRO	touchscreen	bakery	Independent	690 (313)	38"X64.8"X45"
	PCE75S/SD-V-PRO	standard	standard	Dependent	600 (272)	38"X55"X38.5"
	PCE75S/SI-V-PRO	standard	standard	Independent	600 (272)	38"X55"X38.5"
	PCE75S/TD-V-PRO	touchscreen	standard	Dependent	600 (272)	38"X55"X38.5"
Electric - 15kW Double Deck	PCE15B/SD-V-PRO	standard	bakery	Dependent	1100 (499)	38"X64.8"X45"
	PCE15B/SI-V-PRO	standard	bakery	Independent	1100 (499)	38"X64.8"X45"
	PCE15B/TD-V-PRO	touchscreen	bakery	Dependent	1100 (499)	38"X64.8"X45"
	PCE15B/TI-V-PRO	touchscreen	bakery	Independent	1100 (499)	38"X64.8"X45"
	PCE15S/SD-V-PRO	standard	standard	Dependent	1040 (472)	38"X64.8"X38.5"
	PCE15S/SI-V-PRO	standard	standard	Independent	1040 (472)	38"X64.8"X38.5"
	PCE15S/TD-V-PRO	touchscreen	standard	Dependent	1040 (472)	38"X64.8"X38.5"
PCE15S/TI-V-PRO	touchscreen	standard	Independent	1040 (472)	38"X64.8"X38.5"	



**NSou**



Since 1898

**WUTHBEND**



**STEAM**



# STEAMERS, KETTLES AND BRAISING PANS

Southbend offers a complete line of Heavy-Duty Steam equipment to compliment our cooking line. We have hundreds of models available ranging from: Rapid Recovery Convection Steamers, Large Volume Kettles and Heavy-Duty Tilting Skillets.

Our braising pans are versatile units that can roast, fry, braise, boil, simmer, thaw, sauté, grill, warm, steam, proof, hold and serve practically any menu item.

Steam jacketed kettles are widely used as a substitute for stock-pot cooking. Kettle cooking is more gentle, highly consistent, and much faster than stock-pot and other cooking methods.

Counter Steamers



Convection Steamers



Kettles



Skillets



# Electric Counter Connectionless Steamers



EZ24-5

### Standard Features for all Counter Steamers

- 304 stainless steel exterior
- 316 stainless steel cooking chamber and coved corners
- Heavy gauge stainless steel door with full perimeter gasket
- Positive lock and seal mechanism with spring release door
- Illuminated power switch
- Ready indicator light
- Cooking indicator light
- 60 min electromechanical timer with end of cycle audible alarm
- Removable stainless steel pan supports
- Electromechanical controls

## EZ18 Narrow Counter Steamer - Manual Fill / Manual Drain



EZ18-3

### Standard Features

- 3-6 Pan
- 4" Legs standard
- Can stack up to 2 units (factory installed only)
- Removable steam diffuser plate
- Add water indicator light with audible alarm
- Selectable timed or continuous cooking mode
- 16 oz. QuickClean treatment included



Model Number	Description	Pan Capacity (2-1/2")	Weight	Dimension WxHxD
EZ18-3	Electric 9 kW Countertop Steamer - 3 pan - Manual Fill	1-3	161 (73)	18.1"x23.1"x29"
EZ18-5	Electric 15 kW Countertop Steamer - 5 pan - Manual Fill	1-5	183 (83)	18.1"x29.5"x29"

## EZ24 Counter Steamer - Manual Fill / Manual Drain



EZ24-3

### Standard Features

- 3-6 Pan
- 4" Legs standard
- Can stack up to 2 units (factory installed only)
- Removable steam diffuser plate
- Add water indicator light with audible alarm
- Selectable timed or continuous cooking mode
- 16 oz. QuickClean treatment included



Model Number	Description	Pan Capacity (2-1/2")	Weight	Dimension WxHxD
EZ24-3	Electric 9 kW Countertop Steamer - 3 pan - Manual Fill	1-3	161 (73)	24"x23.1"x25"
EZ24-5	Electric 15 kW Countertop Steamer - 5 pan - Manual Fill	1-5	183 (83)	24"x29.5"x25"



# Electric Counter Convection Steamers

## R24 Counter Steamer - Auto Fill / Auto Drain



R24-5

### Standard Features

- 3-5 Pans
- Can stack up to 2 units
- Automatic water fill system
- Auto drain system
- On/off power switch
- Low water indicator light
- Water in "Y" strainer
- Water Treatment System

Model Number	Description	Pan Capacity (2-1/2")	Weight	Dimension WxHxD
R24-3	Electric 7.5 kW Countertop Steamer - 3 pan	1-3	141 (64)	24"X19.1"X27.5"
R24-5	Electric 15 kW Countertop Steamer - 5 pan	1-5	169 (77)	24"X25.5"X27.5"

## R18A-4M Narrow Counter Steamer - Auto Fill / Manual Drain



R18A-4M

### Standard Features

- 4 Pans
- 4" Adjustable Legs standard
- Can stack up to 2 units
- Automatic water fill system
- Manual drain system
- Removable steam diffuser plate
- Water in "Y" strainer
- Water Treatment System

Model Number	Description	Pan Capacity (2-1/2")	Weight	Dimension WxHxD
R18A-4M	Electric 10 kW Narrow Countertop Steamer - 4 pan	1-4	112 (51)	18"x26.5"x29"

## R18A-4 Narrow Counter Steamer - Auto Fill / Auto Drain



R18A-4

### Standard Features

- 4 Pans
- Can stack up to 2 units
- Automatic water fill system
- Automatic drain system
- On/off power switch
- Water in "Y" strainer
- Water Treatment System

Model Number	Description	Pan Capacity (2-1/2")	Weight	Dimension WxHxD
R18A-4	Electric 10 kW Narrow Countertop Steamer - 4 pan	1-4	112 (51)	18"x26.5"x29"



# Electric Counter Convection Steamer

## NEW! Electric Counter Steamer - Auto Fill / Manual Drain



CSE-4-SB

### Standard Features

- 4-6 Pans
- Energy Star Compliant (CSE-4-SB)
- Stackable for 8, 10 & 12 pan capacity
- Auto Fill/Manual Drain
- 4-Position cooking mode selector - Pulls out for easy service access
- Clean Probe Indicator Light
- Heating Indicator Light
- 60-Minute Timer
- Water Treatment System



Model Number	Description	Pan Capacity (2-1/2")	Weight	Dimension WxHxD
CSE-4-SB	Electric 9.8 kW Energy Star Compliant Countertop Steamer - 4 pan	1-4	160 (72)	24"x26.6"x30"
CSE-6-SB	Electric 9.8 kW Countertop Steamer - 6 pan	1-6	181 (82)	24"x33"x30"

Option	Description
Stacking Kit CSE	Stacking kit for two units (CSE-4-SB,/CSE-6-SB)

## NEW! Electric Counter Portion Steamer - Auto Fill / Auto Drain



PSEN-2-SB

### Standard Features

- Two compartments (each holds one 1/3 size x 2.5" deep pan)
- Ready indicator light (175°F preheat)
- Cooking indicator light
- Removable stainless steel pan supports
- Heating Indicator Light
- 60-Minute Timer
- Water Treatment System

Model Number	Description	Pan Capacity (2-1/2")	Weight	Dimension WxHxD
PSE-2-SB	Electric Countertop Portion Steamer - Side by Side	1-2	160 (72)	22.75"x15.25"x23"
PSEN-2-SB	Electric Countertop Portion Steamer	1-2	181 (82)	15.875"x18.875"x23"

# Gas Counter Convection Steamer



SX-5G3

Gas counter top convection steamer with atmospheric steam generator

### Standard Features

- Stainless steel construction
- Coved interior corners
- Automatic generator blow down valve
- Delime mode power setting
- Split water connections for simple hook up for a treated water system.
- 4" Adjustable legs standard
- Water Treatment System

## Gas Counter Steamer - Auto Fill / Auto Drain

Model Number	Description	Pan Capacity	Weight	Dimension WxHxD
SX-5G3-SB	Gas 47K BTU Countertop Steamer (5 pan) - Auto Fill / Auto Drain	1-5	250 (113)	24"X25"X32.5"



# Options and Accesories

Model Number	Options and Accessories
TS-120-1	120 Minute Timer (Electric Steamer Only) one compartment.
TS-120-2	120 Minute Timer (Electric Steamer Only) two compartment.
HSB-1	High Sensitivity Board for reverse osmosis water (208/240volt) one compartment ( <b>R24-3 &amp; R24-6</b> ).
HSB-2	High Sensitivity Board for reverse osmosis water (208/240volt) two compartment ( <b>R24-3 &amp; R24-6</b> ).
CSF-1	Constant Steam Feature. Priced per compartment ( <b>R18A-4M , R18A-4, R24-3 &amp; R24-6</b> )
SSL-4	Stainless Steel 4" High Legs ( <b>R18A-4,R18A-4M, R24-3 &amp; R24-6</b> )
CSFF-4	Counter steamer flanged feet
SK-1	Stacking Kit For Two Units ( <b>R18A-4, R18A-4M, R24-3 &amp; R24-6</b> )
SIP-2	Interconnect Plumbing For Two Units ( <b>R24-3, R24-6, R18A-4 &amp; R18A-4M</b> )
SHS	Heat shields (per compartment)
S75-10	7.5KW increased to 10KW ( <b>R24-3</b> )
SEVS-5	380, 415, 440, 460 or 480 Volts, 3 Phase, 50 or 60 Hertz ( <b>R18A-4M, R18A-4, R24-3, R24-6, EZ18-3 &amp; EZ18-6</b> )
SEVS-6	575 or 600 Volts, 3 Phase, 50 or 60 Hertz ( <b>EZ18-3, R24-3 &amp; R24-6</b> )
SGVS-1	220 Volts, 1 phase, 50 or 60 Hertz ( <b>SX-6G3</b> )
DHK	Drain Hose Kit includes 5' hose with fitting ( <b>R18A-4M, EZ18-3, EZ18-6, EZ24-3 &amp; EZ24-6</b> )
SPR-1	Extra Rack ( <b>R24-6</b> )
<b>Stands and Caster options</b>	
RL28	Single Unit 28" High Stand: ( <b>R24-3 or R24-6</b> )
RL28X	Single Unit 28" High Stand: ( <b>EZ24-3 or EZ24-6, CSE-4 or CSE-6</b> )
CK-2	Casters, 3" High, Set of 4 ( <b>EZ24-3 and EZ24-6 with RL28X-SB stand only</b> )
RL23XN	Double Units 23" High Stand: ( <b>R18A-4M or R18A-4</b> )
RL28XN	Single Unit 28" High Stand: ( <b>R18A-4M, R18A-4, EZ18-3 or EZ18-6</b> )
RL28G	Single Unit 28" High Stand: ( <b>SX-6G3</b> )
RL34	Single Unit 34" High Stand: ( <b>R24-3 or R24-6</b> )
RL18	Double Unit 18" High Stacking Stand: (2) <b>R24-6</b> Units
RL18X	Double Unit 18" High Stacking Stand: (2) <b>CSE-6</b> Units
RL23	Double Unit 23" High Stacking Stand: (2) <b>R24-3</b> Units
RL23X	Double Unit 23" High Stacking Stand: (2) <b>CSE-4 or CSE-4 on CSE-6</b>
R18SS-3	Double Unit Stacking Stand, 60" Total Height for (2) <b>EZ18-3</b> Units (Factory Installed Only)
R18SS-3	Double Unit Stacking Stand, 66" Total Height for <b>EZ18-3</b> over <b>EZ18-6</b> (Factory Installed Only)
R18SS-5	Double Unit Stacking Stand, 69" Total Height for (2) <b>EZ18-6</b> Units (Factory Installed Only)
S-EPXSS-1	Double Unit Stacking Stand, 58" Total Height for (2) <b>EZ24-3</b> Units (Factory Installed Only)
S-EPXSS-1	Double Unit Stacking Stand, 64" Total Height for <b>EZ24-3</b> over <b>EZ24-6</b> (Factory Installed Only)
S-EPXSS-2	Double Unit Stacking Stand, 71" Total Height for (2) <b>EZ24-6</b> Units (Factory Installed Only)

# Boilerless Convection Steamers



Sirius II-10-SB

## Sirius II Series

Available in five capacities. Features a convection fan that increases steam velocity and distribution efficiency by pulling moist hot air past food, then forcing it against cooking chamber to be reheated.

## Standard Features

- Internally preheated incoming water for quick recovery
- Circulating fan for fast cooking times
- Cast aluminum cooking compartment provides superior temperature retention
- Water sensing probe, water-fill timer, manual front drain valve
- Clean water reservoir system (keeps food out of the water)
- Clean probe indicator light and heating indicator light
- 3-cooking positions; low temp/steam/super steam
- Condensate trough plumbed to drain at rear
- Control panel pulls out for easy service access
- Redundant safety systems
- 60-minute mechanical timer
- Choose from propane or natural gas
- Water Treatment System

## Sirius II Series Boilerless Countertop & Stacked Gas Steamers

Model Number	Description	Weight	Dimension WxHxD
Sirius II-4-SB	4 pan Countertop steamer - 27,000 BTU*	225 (102)	24"x26.25"x28.75"
Sirius II-6-SB	6 pan Countertop steamer - 27,000 BTU*	250 (113)	24"x33.25"x28.75"
Sirius II-8-SB	Two (4) pan steamers with stacking kit - 52,000 BTU*	450 (204)	24"x52.63"x28.75"
Sirius II-10-SB	One (4) pan and one (6) pan steamer with stacking kit - 52,000BTU*	475 (215)	24"x63.63"x28.75"
Sirius II-12-SB	Two (6) pan steamers with stacking kit - 52,000BTU*	500 (226)	24"x70.63"x28.75"

\* For Natural Gas (26,000 and 52,000 for Propane)

Capacity (Pan Height - 12" x 20" Pan)			
1"	2.5"	4"	6"
8	4	2	1
12	6	3	2
16	8	4	2
20	10	5	3
24	12	6	4



# Steam-It Pressure Steam Cooker



ST-E-SB

## Steam-It Countertop Pressure Cooker

The Steam-It cooks fresh seafoods, vegetables, pasta, poultry and eggs in just minutes. Steam 30 lbs. of potatoes in 30 minutes and six 1 lb. lobsters in 6 minutes. The Steam-It with three pans can out perform larger capacity steamers.

### Standard Features

- Compact - requires just 18-3/4" of counter space
- Self-contained unit DOES NOT require plumbing or drain connection
- Mounts on any surface with four 6" adjustable legs
- 60-minute timer with audible alarm (signals end of cooking cycle)
- Low water cut-off switch
- Manual water fill and drain
- ASME vessel

## Steam-It Electric Countertop Pressure Steam Cookers

Model Number	Description	Weight	Dimension WxHxD
ST-E-SB	3 pan electric pressure cooker - 9/12kW	125 (57)	18.375"x26.25"x31.5"
SB-ST-E-SB	Shipboard Steam-It - Submarine model, 440 or 480V - (4) flanged counter feet, marine wiring, (6) 2.5" perforated pans, water retainer, spray hose and step down transformer (NSN 7310-01-102-2673) - 12kW	175 (79)	18.375"x30.25"x31.5"

Pan capacity: (3) 12"x20"x2.5", (2) 12"x20"x4"

## Options and Accessories

Model Number	Description
08-5213	Set of 4, Stainless Steel Feet for Counter-Mounted Steam-It's
95-0436	Cold Water Condensing Kit
98-1522	6" Flanged Foot, set of 4 (In Lieu of Bullet Feet)
95-3849	Spray Hose for ST-E
95-6060	Stainless Steel Stand - 28" High (Models ST-E Only)
95-6054	Extra Shelf for 28" High Stainless Steel Stand
-	480 Volt Operation, add

## Options and Accessories



MSS 92-1012-SB with Casters  
SSS 92-1014-SB without Casters  
for 4 and 6 pan models



STSM 92-1021-SB with Casters  
STSS 92-1015-SB without Casters  
for 8, 10 and 12 pan models

Model Number	Description	Weight
<b>FOR SIRIUS II STEAMERS</b>		
92-1000	CA HD Caster set of four, two with brakes (Equipment ONLY)	12/5
92-1002	HWS-4 Heat and water shield, left side, 4-pan compartment	–
92-1003	HWS-6 Heat and water shield, left side, 6-pan compartment	–
–	480 Volt Operation, add	–
98-1522	6" Flanged foot, set of 4 (in lieu of bullet feet)	–
92-1012	MSS Mobile Stand with Slide Out Work Shelf & Under Shelf (34.50" tall)	–
92-1013	PRM Pan Rack Assy. (for MSS & SSS, holds (10) 2" deep pans)	35/16
92-1014	SSS Stationary Stand w/Slide Out Work Shelf & Under Shelf (29.75" tall)	23/10
92-1015	STSS Stationary Stand 12" High	45/20
92-1021	STSM Mobile Stand 16-5/8" High	60/27
98-4216	Water Hose kit; 60" Line Quick Disconnect, 3/8" NPT	–
08-7673	Quick Disconnect, Gas Hose with Strain Device, 3/4 NPT, 48" Long (Sirius II ONLY)	–
08-7674	Quick Disconnect, Gas Hose with Strain Device, 3/4 NPT, 60" Long (Sirius II ONLY)	–

\* Per Compartment



09-2216

Model Number	Description	Weight
09-2216	12" x 20" x 1" Solid Pan	3 (1.4)

\* Per Compartment

# Twin Generator Convection Steamers



SX-10G3-SB

GSX-10HE-SB

### Standard Features

- Stainless steel construction
- 316 stainless steel cooking chamber
- POWERFUL self-contained atmospheric steamer
- Unique, high output steam injectors for quick recovery and increased production
- Available in 10 pan and 16 pan models.
- Water Treatment System

High Performance - High Efficiency

## Compartment Individual Generators on Cabinet Base

Model Number	Description	Weight	Dimension WxHxD
<b>High Efficiency/Performance Pressureless Steamers</b>			
GSX-10HE-SB	Gas Convection Steamer - 10 pan (two 5 pans), 24" cabinet base - 190,000 BTU	700 (318)	24"x72"x33.13"
GSX-16HE-SB	Gas Convection Steamer - 16 pan (two 8 pans), 36" cabinet base - 190,000 BTU	900 (408)	36"x70.375"x33.13"

Model Number	Options and Accessories
SEVS-1	380, 3-phase 50 or 60 Hz (Specify)
SEVS-2	415, 3-phase 50 or 60 Hz (Specify)
SEVS-3	440,460,480 VAC, 3-phase 50 or 60 Hz (Specify)
SEVS-4	575 or 600 VAC, 3-phase, 60 Hz
SEPG-1	Rack pan guides in cabinet base
SGVS-2	220/1/50 or 60Hz controls per compartment
CK-3	A set of (4) 5" Casters (GSX-10HE-SB and GSX-16HE-SB ONLY)
SPS-1	Sheet pan supports (18x26) in lieu of standard pan supports – 16 pan only per compartment
SPS-2	Sheet pan supports (18x26) supplied with standard pan supports – 16 pan only per compartment
CSF-1	Constant steam feature. Priced per compartment (SX-55EC-SB)



# Atmospheric Steam Generators



ETP-10G-SB

## Eco-Tech Plus® Series

This industry first ENERGY STAR qualified steamer, with a built-in water filter system, incorporates a water management system that reduces the amount of water used to condense generated steam, while adding substantial savings on energy-related costs. SAVE 80 to 100 gallons of water per hour over other convection steamers.

## Standard Features

- Built-in water treatment system and water management system
- Independent steam generator for each compartment
- Automatic water level control and low water cut-off
- Steam on demand feature
- Illuminated 3 way ON/OFF/delime power switch
- Slam action doors and door interlock switch
- 60-minute timer
- Four 6" adjustable flanged feet
- Can be used as holding cabinet

## Eco-Tech Plus® Series Floor Model Electric & Gas Steamers

Model Number	Description	Weight	Dimension WxHxD
ETP-10E-SB	10 pan electric floor model steamer - 20KW	425 (193)	24"x63.25"x33"
ETP-10G-SB	10 pan gas floor model steamer - 84,000BTU	525 (238)	24"x64"x33"

\* Add 12.25" (311mm) for the flue for overall height  
Pan capacity: (10) 12"x20"x2.5", (6) 12"x20"x4"

## Options and Accessories

Model Number	Description
98-4216	Water Hose Kit, 60" Line w/Quick Disconnect, 3/8" NPT (1 hose per kit)
CK-3	A set of (4) 5" Casters
SEVS-5	480 volt operation, add
GSVS-1	220 volt operation for gas models
HTC	Export crating - NET per/section
Prison Options	
P-TPSTW	Tamper proof screws & tackwelds - where applicable
P-HCC-ETP	Hinged cover over control panel
P-CBL-1	Cabinet base door w/ locking provision
P-IF-1	Insulated flue cover
P-PF-BB	Perforated flue cover



# GUIDELINES FOR CHOOSING BOILER SIZE

## Available Kettle Capacity for Common Steamers Using a Steam Take-off

Model Number	Input	Additional Kettle Capacity
GCX-2S	std 200,000 BTU	10 gallon 20 gallon
GCX-2S-36	std. 250,000 BTU opt 300,000 BTU	10 gallon 30 gallon 40 gallon 50 gallon
ECX-2S	std 24 kW opt 36 kW opt 42 kW	n/a 20 gallon 40 gallon
ECX-2S-36	std 24 kW opt 36 kW opt 42 kW opt 48 kW (voltage over 208 only)	n/a 20 gallon 40 gallon 40 gallon

## Boiler Steam Output

Input	lbs. per hour
<b>Gas</b>	
200,000 BTU (24" base)	110
250,000 BTU (36" base)	155
300,000 BTU (36" base)	183
<b>Electric</b>	
24 kW	69
36 kW	107
42 kW	128
48kW	148
<b>Steam Coil</b>	
20 PSI	90
30 PSI	138
40 PSI	172
50 PSI	207

## Steam Requirements

Input	lbs. per hour
<b>Kettle (gallons)</b>	
TOC-2-SB	5.5
6	11
10	22
20	44
30	66
40	88
60	132
80	176
100	220
<b>Convection Steam Compartments</b>	
6 Pan	30 (per compartment)
10 Pan	45 (per compartment)

## Cooker Guidelines

STEAM FLOW RATE REQUIREMENTS OF SOUTHBEND STEAMERS (lbs. Per hour @ 10 psig)		
Model (Series)	Rate required at start up per compartment	Rate required during cooking per compartment
Convection Steamers	30	30
Pressure Steamers	30	15
Do-All Steamers (Full Size) (Pressure Mode) (Convection Mode)	62 62	15 62
Do-All Steamers (Half Size) (Pressure Mode) (Convection Mode)	30 30	12 30

Direct steam kettles require a steam trap for operation. Depending on the installation, a steam trap, inlet globe valve, pressure reducing valve, line strainer, and/or ball float trap must be installed with suitable piping and plumbing fittings. These items may be ordered as an option at extra cost from Southbend or may be provided by others.

Food service boilers have a limited steam reservoir. When multiple pieces of equipment are powered by a single boiler, each kettle or compartment should be heated sequentially, allowing the boiler to recover pressure before starting the next piece of equipment.

Boiler drain lines discharge hot condensate and steam which may affect the operation of the boiler or other equipment. Drain outlets should be plumbed indirectly to a floor drain outside the confines of the boiler and away from other equipment.

Remote boiler sizing requires consideration of the size, length and type of pipe used, as well as the number of bends and joints. Southbend recommends the use of a professional food service consultant or mechanical engineer for remote boiler specification.

# Convection Steamers with Cabinet Base



DCX-10S

### Standard Features

- Stainless steel construction for easy cleaning and rust prevention
- 316 stainless steel cooking chamber
- Coved corners
- Easy to operate controls
- Easy open, heavy-duty door with quick release handle
- Auto steam generator blowdown - standard
- 6 pan capacity
- CSD Code Package standard
- Electronic Ignition - boiler base models
- Water Treatment System
- Nickel plated boiler

## 6 Pan Convection Steamer

Model Number	Description	Boiler Base	Weight	Dimensions WxHxD
DCX-2S	6 Pan, Two Compartment Steamer with 24" Cabinet Base	Direct Steam	450 (204)	24"x55.5"x33"
SCX-2S		Steam Coil	500 (227)	24"x55.5"x33"
ECX-2S		Electric Boiler- 24 kW	550 (250)	24"x55.5"x33"
GCX-2S		Gas Boiler- 200,000 BTU	630 (286)	24"x55.5"x33"
DCX-2S-36	6 Pan, Two Compartment Steamer with 36" Cabinet Base	Direct Steam	600 (273)	36"x55.5"x33"
SCX-2S-36		Steam Coil	600 (272)	36"x55.5"x33"
ECX-2S-36		Electric Boiler- 24 kW	650 (255)	36"x55.5"x33"
GCX-2S-36		Gas Boiler- 250,000 BTU	764 (347)	36"x55.5"x33"

## 10 Pan Convection Steamer

Model Number	Description	Boiler Base	Weight	Dimension WxHxD
DCX-10S	10 Pan, Two Compartment Steamer with 24" Cabinet Base	Direct Steam	550 (250)	24"x68.5"x33"
SCX-10S		Steam Coil	575 (260)	24"x68.5"x33"
ECX-10S		Electric Boiler- 36 kW	575 (260)	24"x68.5"x33"
GCX-10S		Gas Boiler- 200,000 BTU	670 (340)	24"x68.5"x33"
DCX-10S-36	10 Pan, Two Compartment Steamer with 36" Cabinet Base	Direct Steam	625 (284)	36"x68.5"x33"
SCX-10S-36		Steam Coil	625 (284)	36"x68.5"x33"
ECX-10S-36		Electric Boiler- 36 kW	700 (317)	36"x68.5"x33"
GCX-10S-36		Gas Boiler- 250,000 BTU	840 (381)	36"x68.5"x33"



# Convection Steamers with Cabinet Base



ECX-16-SB



GCX-24-SB

### Standard Features

- 16 or 24 Pan capacity
- Manual controls
- Electronic ignition (Gas)
- CSD-1 boiler controls (Gas & Electric)
- Split water line
- Automatic blowdown

## 16 Pan Convection Steamer

Model Number	Description	Boiler Base	Weight	Dimensions WxHxD
DCX-16-SB	16 Pan, Two Compartment Steamer with 36" Cabinet Base	Direct Steam	750 (340)	36"x62"x33"
SCX-16-SB		Steam Coil	800 (363)	36"x62"x33"
ECX-16-SB		Electric Boiler- 42 kW	900 (408)	36"x62"x33"
GCX-16-SB		Gas Boiler- 300,000 BTU	800 (363)	36"x62"x33"

## 24 Pan Convection Steamer

Model Number	Description	Boiler Base	Weight	Dimensions WxHxD
DCX-24-SB	24 Pan, Two Compartment Steamer with 36" Cabinet Base	Direct Steam	800 (363)	36"x70"x33"
SCX-24-SB		Steam Coil	850 (386)	36"x70"x33"
ECX-24-SB		Electric Boiler- 42 kW	950 (431)	36"x70"x33"
GCX-24-SB		Gas Boiler- 300,000 BTU	990 (450)	36"x70"x33"

## Water Treatment System

Middleby's TruH2O water treatment systems provide the necessary technology to control chlorine, sediment and to solve scale problems. Our water treatment system is effective in all water conditions.

- Neutralizes scale
- Up to 99% chlorine reduction
- 5 micron filtration
- Incoming PH factor should be greater than 7.3
- Easy cartridge change out
- Quick disconnect fittings
- Up to 6 month cartridge life\*

\*-In areas with known high levels of water hardness, more frequent replacement of scale inhibitor cartridges may be necessary, possibly every 3 months.



### Stage 1 - Carbon

Our carbon block cartridge will remove up to 99% of the chlorine in water.

### Stage 2 - Citryne

This Southbend water treatment system provides the necessary technology to solve scale problems. Our water treatment is effective in all water scale conditions.



# Convection Steamers with Kettles



DCX-10S-6-10

## Standard Features

- Stainless steel construction for easy cleaning and rust prevention
- 316 stainless steel cooking chamber
- Coved corners
- Easy to operate controls
- Easy open, heavy-duty door with quick release handle
- Auto steam generator blowdown - standard
- 10 pan capacity
- CSD Code Package standard
- Electronic Ignition - boiler base models
- Water Treatment System
- Nickel plated boiler

## 6 Pan Convection Steamer with Kettles

Model Number	Description	Boiler Base	Weight	Dimensions WxHxD
DCX-2S-6	6 Pan, Two Compartment Steamer with 6 Gallon Kettle and 44" Cabinet Base	Direct Steam	650 (295)	44"x62.1"x33"
SCX-2S-6		Steam Coil	700 (318)	44"x62.1"x33"
ECX-2S-6		Electric Boiler- 36 kW	880 (400)	44"x66.1"x33"
GCX-2S-6		Gas Boiler- 250,000 BTU	980 (445)	44"x66.1"x33"
DCX-2S-10	6 Pan, Two Compartment Steamer with 10 Gallon Kettle and 48" Cabinet Base	Direct Steam	700 (318)	48"x61.1"x33"
SCX-2S-10		Steam Coil	750 (340)	48"x61.13"x33"
ECX-2S-10		Electric Boiler- 36 kW	930 (422)	48"x65.1"x33"
GCX-2S-10		Gas Boiler- 250,000 BTU	1030 (467)	48"x65.1"x33"
DCX-2S-6-6	6 Pan, Two Compartment Steamer with (2) 6 Gallon Kettle and 60" Cabinet Base	Direct Steam	830 (377)	60"x62.1"x33"
SCX-2S-6-6		Steam Coil	930 (422)	60"x62.1"x33"
ECX-2S-6-6		Electric Boiler- 42 kW	840 (381)	60"x66.13"x33"
GCX-2S-6-6		Gas Boiler- 250,000 BTU	930 (422)	60"x66.1"x33"
DCX-2S-6-10	6 Pan, Two Compartment Steamer with (1) 6 Gallon Kettle and (1) 10 Gallon Kettle and 60" Cabinet Base	Direct Steam	870 (395)	60"x62.1"x33"
SCX-2S-6-10		Steam Coil	970 (440)	60"x62.1"x33"
ECX-2S-6-10		Electric Boiler- 42 kW	880 (400)	60"x66.13"x33"
GCX-2S-6-10		Gas Boiler- 250,000 BTU	970 (440)	60"x66.1"x33"

## 10 Pan Convection Steamer with Kettles

Model Number	Description	Boiler Base	Weight	Dimension WxHxD
DCX-10S-6	10 Pan, Two Compartment Steamer with 6 Gallon Kettle and 44" Cabinet Base	Direct Steam	900 (408)	44"x68.5"x33"
SCX-10S-6		Steam Coil	1000 (453)	44"x68.5"x33"
ECX-10S-6		Electric Boiler- 36 kW	900 (408)	44"x72.5"x33"
GCX-10S-6		Gas Boiler- 250,000 BTU	1000 (453)	44"x72.5"x33"
DCX-10S-10	10 Pan, Two Compartment Steamer with 10 Gallon Kettle and 48" Cabinet Base	Direct Steam	920 (417)	48"x68.5"x33"
SCX-10S-10		Steam Coil	1020 (462)	48"x68.5"x33"
ECX-10S-10		Electric Boiler- 36 kW	920 (408)	48"x72.5"x33"
GCX-10S-10		Gas Boiler- 250,000 BTU	1020 (462)	48"x72.5"x33"
DCX-10S-6-6	10 Pan, Two Compartment Steamer with (2) 6 Gallon Kettle and 60" Cabinet Base	Direct Steam	1000 (453)	60"x68.5"x33"
SCX-10S-6-6		Steam Coil	1000 (453)	60"x68.5"x33"
ECX-10S-6-6		Electric Boiler- 42 kW	1020 (462)	60"x72.5"x33"
GCX-10S-6-6		Gas Boiler- 250,000 BTU	1020 (462)	60"x72.5"x33"
DCX-10S-6-10	10 Pan, Two Compartment Steamer with (1) 6 Gallon Kettle and (1) 10 Gallon Kettle and 60" Cabinet Base	Direct Steam	1000 (453)	60"x68.5"x33"
SCX-10S-6-10		Steam Coil	1000 (453)	60"x68.5"x33"
ECX-10S-6-10		Electric Boiler- 42 kW	1020 (462)	60"x72.5"x33"
GCX-10S-6-10		Gas Boiler- 250,000 BTU	1020 (462)	60"x72.5"x33"





# Do-All Compartment Cooker



DDA-2S

### Standard Features

- Manual controls
- Automatic timers
- Split water lines
- Universal pan guides
- CSD-1 boiler controls (Electric & Gas)
- Electronic Ignition (Gas)
- Direct Steam c/w PRV pressure reducing valve
- "Y" strainer
- 36" Cabinet Base

## Large Capacity Steamer with Boiler Base

Model Number	Description	Weight	Dimension WxHxD
DDA-2S	Direct Steam, 2 Compartment large capacity steamer	600 (272)	36"x55.13"x33.88"
SCDA-2S	Steam Coil, 2 Compartment large capacity steamer	1050 (477)	36"x55.13"x33.88"
EDA-2S	Electric Broiler - 42 KW, 2 Compartment large capacity steamer	1050 (477)	36"x55.13"x33.88"
GDA-2S	Gas Boiler - 250,000 BTU, 2 Compartment large capacity steamer	1050 (477)	39"x55"x33"
DDA-3S	Direct Steam, 3 Compartment large capacity steamer	825 (374)	36"X68"x33.8"
SCDA-3S	Steam Coil, 3 Compartment large capacity steamer	994 (451)	36"X68"x33.8"
EDA-3S	Electric Broiler - 42 KW, 3 Compartment large capacity steamer	1110 (503)	36"X68"x33.8"
GDA-3S	Gas Boiler - 250,000 BTU	1180 (535)	39"X68"x33.8"

Pressure/Pressureless mode top compartment only. Unit standard with Auto Blowdown and CSD Package.

LARGE CAPACITY STEAMERS ARE IDEAL FOR HIGH VOLUME COOKING.



# Pressure Steamer - Compartment Cooker



DC-2S



GC-3S

### Standard Features

- Manual controls
- Automatic timers
- Split water lines
- Universal pan guides
- CSD-1 boiler controls (Electric & Gas)
- Electronic Ignition (Gas)
- Direct Steam c/w PRV pressure reducing valve
- "Y" strainer
- 36" Cabinet Base

### Pressure Compartment Steamer with Base

Model Number	Description	Weight	Dimension WxHxD
EC-2S	2 Compartment with Elec. Generator - 24kW	960 (435)	36"x55.13"x33.88"
EC-3S	3 Compartment with Elec. Generator - 24kW	1100 (499)	36"x68"x33.88"
<i>standard: 208, 230, 240/60/3</i>			
GC-2S	2 Compartment with Gas Boiler - 250,000 BTU	1100 (499)	36"x55.13"x33.88"
GC-3S	3 Compartment with Gas Boiler - 250,000 BTU	1170 (531)	36"x68"x33.88"
<i>standard: 115/60/1 controls only</i>			
DC-2S	2 Compartment with Direct Steam	560 (255)	36"x55.13"x33.88"
DC-3S	3 Compartment with Direct Steam	815 (370)	36"x68"x33.88"
SC-2S	2 Compartment with Steam Coil	815 (370)	36"x55.13"x33.88"
SC-3S	3 Compartment with Steam Coil	950 (432)	36"x68"x33.88"
<i>standard: 115/60/1 controls only</i>			



DCL-2S



DCP-3S

### Standard Features

- Automatic timers
- Universal pan guides

### Direct Steam Compartment Steamers (Floor, Table and Wall Mount)

Model Number	Description	Weight	Dimension WxHxD
DCL-2S	2 compartments on legs	575 (261)	36"x55"x28"
DCL-3S	3 compartments	825 (375)	36"x58"x28"
DCP-2S	2 compartments - pedestal base	615 (280)	36"x45.4"x33"
DCP-3S	3 compartments - pedestal base	875 (398)	36"x58.3"x33"
<i>standard: 115/1/60</i>			



# Boiler Base and Direct Steam Kettles



DMT-6S

GMT-10S-10

Great for High Volume Institutional Kitchens!

### Standard Features

- Double pantry faucet
- Steam control valve
- 316 Stainless Steel liner
- Automatic blowdown
- Split water line

## Steam Kettles on 24" Boiler Base

Model Number	Description	Weight	Dimension WxHxD
GMT-6S	Gas boiler with 6 gallon kettle - 200,000 BTU	450 (204)	24"x56.75"x33"
GMT-10S	Gas boiler with 10 gallon kettle - 200,000 BTU	470 (213)	24"x55.75"x33"
EMT-6S	Electric boiler with 6 gallon kettle - 24kW	450 (204)	24"x66.13"x33"
EMT-10S	Electric boiler with 10 gallon kettle - 24kW	470 (213)	24"x65.13"x33"
DMT-6S	Direct Steam with 6 gallon kettle	225 (102)	24"x62.13"x33"
DMT-10S	Direct Steam with 10 gallon kettle	245 (111)	24"x61.13"x33"

## Steam Kettles on 36" Boiler Base

Model Number	Description	Weight	Dimension WxHxD
GMT-6S-6	Gas boiler with two 6 gallon kettles- 250,000 BTU	450 (204)	36"x63"x33"
EMT-6S-6	Electric boiler with two 6 gallon kettles - 24kW	600 (272)	36"x66.13"x33"
DMT-6S-6	Direct Steam with two 6 gallon kettles	350 (159)	36"x58.75"x33"

## Steam Kettles on 42" Boiler Base

Model Number	Description	Weight	Dimension WxHxD
GMT-10S-6	Gas boiler with 10 gallon and 6 gallon kettles - 250,000 BTU	570 (259)	42"x58.75"x33"
EMT-10S-6	Electric boiler with 10 gallon and 6 gallon kettles - 24kW	700 (317)	42"x66.13"x33"
DMT-10S-6	Direct Steam with 10 gallon and 6 gallon kettles	800 (368)	36"x58.75"x33"
GMT-10S-10	Gas boiler with two 10 gallon kettle - 250,000 BTU	820	42"x65.13"x33"
EMT-10S-10	Electric boiler with two 10 gallon kettle - 24kW	720	42"x61.2"x33"
DMT-10S-10	Direct Steam with 10 gallon kettle	390	42"x61.2"x33"
STOK	Optional steam take-off		



# Boiler Base



CE-36S

### Standard Features

- Electronic Ignition
- CSD-1 boiler controls
- Split water line
- Automatic blowdown
- Steam take off kit

## Boiler in 24" Cabinet

Model Number	Description	Weight	Dimension WxHxD
CE-24S	Electric - 24 kW	350 (159)	24"x28"x33"
CE-36S	Electric - 36 kW	350 (159)	24"x28"x33"
CE-42S	Electric - 42 kW	350 (159)	24"x28"x33"
CE-48S	Electric - 48 kW (240 volt and higher)	350 (159)	24"x28"x33"
CG-20S	Gas - 200,000 BTU	375 (170)	24"x55"x33"

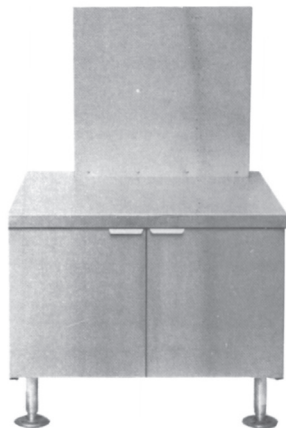

CG-325S

### Standard Features

- Electronic Ignition
- CSD-1 boiler controls
- Split water line
- Automatic blowdown
- Steam take off kit

## Boiler in 36" Cabinet

Model Number	Description	Weight	Dimension WxHxD
CE-324S	Electric - 24 kW	390 (177)	36"x28"x33"
CE-336S	Electric - 36 kW	415 (188)	36"x28"x33"
CE-342S	Electric - 42 kW	415 (188)	36"x28"x33"
CE-348S	Electric - 48 kW (240 volt and higher)	475 (215)	36"x28"x33"
CG-325S	Gas - 250,000 BTU	475 (215)	36"x55"x33"
CG-330S	Gas - 300,000 BTU	475 (215)	36"x55"x33"



# Oyster Cookers



TOC-2S

### Standard Features

- 316 Stainless Steel

## Oyster Cookers

Model Number	Description	Weight	Dimension WxHxD
TOC-2S	Oyster Cooker - Direct steam, 2 liter capacity	35 (16)	12.4"X17.9"X10"



OB-3-2-40-E-SB

### Standard Features

- Water Treatment System
- CSD-1 boiler controls
- Electronic ignition
- Split water line
- Automatic boiler blowdown

## Oyster Bar - Electric

Model Number	Description	Weight	Dimension WxHxD
OB-2-2-27-E-SB	(2) Tilting Oyster Cooker - 27" Electric Boiler Base -24 kw	260 (118)	27"X54"X33.13"
OB-3-2-40-E-SB	(3) Tilting Oyster Cooker - 40" Electric Boiler Base -24 kw	contact factory	40"X54"X33.13"
OB-4-2-54-E-SB	(4) Tilting Oyster Cooker - 54" Electric Boiler Base -24 kw	400 (181)	54"X54"X33.13"

## Oyster Bar - Gas

Model Number	Description	Weight	Dimension WxHxD
OB-2-2-27-G-SB	(2) Tilting Oyster Cooker - 27" Gas Boiler Base -200k BTU	285 (129)	27"X54"X33.13"
OB-3-2-40-G-SB	(3) Tilting Oyster Cooker - 40" Gas Boiler Base -250k BTU	contact factory	40"X54"X33.13"
OB-4-2-54-G-SB	(4) Tilting Oyster Cooker - 54" Gas Boiler Base -250k BTU	425 (193)	54"X54"X33.13"



## Options and Accessories

Model Number	Options and Accessories
B24-36	24kW increase to 36kW
B24-42	24kW increase to 42kW
B24-48	24kW increase to 48kW (voltages over 208 only)
B36-42	36kW increase to 42kW
B36-48	36kW increase to 48kW (voltages over 208 only)
B42-48	42kW increase to 48kW (voltages over 208 only)
B25-30	250,000 BTU increased to 300,000 btu (36" cabinet only)
SP-RSH	Single pantry rinse spray head with 68" hose
DP-RSH	Double pantry rinse spray head with 68" hose
PRV-2	Pressure regulating valve (20-60 psi) for sche (3-pr62)
BFT	Ball float trap (painted)
STOK	Steam take-off kit for steam kettles
LCT-1	Load compensating timer - pressureless steamers (1 compartment)
LCT-2	Load compensating timer - pressureless steamers (2 compartment)
YS-1	Water in 'Y' strainer
BDSG	Boiler door sight glass
EBVS-1	380 or 415 volts, 60 hz, 3 phase (specify)
EBVS-2	440, 460 or 480 volts, 60 hz, 3 phase (specify)
EBVS-3	575 or 600 volt, 60 hz, 3 phase (specify)
GBVS-1	220/150 or 60 hertz control (specify)
DBVS-1	220-240 (specify) voltage upcharge for Direct Steam Cookers
HTC	Export heat-treat crating
SSB-24	24" wide stainless steel back for boiler base unit
SSB-36	36" wide stainless steel back for boiler base unit
SSB-42	42" wide stainless steel back for boiler base unit
SSB-44	44" wide stainless steel back for boiler base unit
SSB-48	48" wide stainless steel back for boiler base unit
SSB-60	60" wide stainless steel back for boiler base unit
SSF-24	24" wide stainless steel frame for boiler base unit
SSF-36	36" wide stainless steel frame for boiler base unit
SSF-42	42" wide stainless steel frame for boiler base unit
SSF-44	44" wide stainless steel frame for boiler base unit
SSF-48	48" wide stainless steel frame for boiler base unit
SSF-60	60" wide stainless steel frame for boiler base unit
SPS-1	Sheet pan supports (18x26) in lieu of standard pan supports – 16 pan only per compartment
SPS-2	Sheet pan supports (18x26) supplied with standard pan supports – 16 pan only per compartment
SPS-24-1	Sheet pan supports (18x26) in lieu of standard pan supports – 24 pan only per compartment
SPS-24-2	Sheet pan supports (18x26) supplied with standard pan supports – 24 pan only per compartment
SPS-PC1	Sheet pan supports (18x26) in lieu of standard pan supports - pressure cookers/per compartment
SPS-PC2	Sheet pan supports (18x26) supplied with standard pans supports - pressure cookers/per compartment
CXSS-16	CXSS-16 wire shelf rack – 16 pan only (price per rack)
SSR-PC	Wire shelf rack for all pressure cookers (price per rack)
NCB-27	Nylon Cutting Board for Oyster Bar -27
NCB-40	Nylon Cutting Board for Oyster Bar -40
NCB-54	Nylon Cutting Board for Oyster Bar -54
DMF-12R-DJ	Deck mount faucet, dual jointed c/w 6" riser & 6" spout (for oyster bars)
8978-1	Floor Protective Panel for 24" Gas Broiler Based Cabinets and up
8976-1	Floor Protective Panel for 36" Gas Broiler Based Cabinets and up



# Counter Kettles



KECT-06

### Standard Features

- Stainless steel construction and liner for high acid content products
- 316 stainless steel liner
- Easy to operate controls with temperature dial, ready light, and low water shut-off
- Removable handle with heat resistant knob (where applicable)
- 50 PSI
- 2" tangent draw-off with perforated strainer and spring assist cover standard on floor model stationary kettles
- Removable elements
- Electric Counter Kettles with dual phase field convertible (208,220,240 volt only)
- 10 year hemi warranty (see warranty statement for full details)

## Electric Counter Steam Kettles

Model Number	Description	Weight	Dimension WxHxD
KECT-06	2/3-jacketed, 6 gallon - 7.5 kw	130 (59)	22.3"x33.5"x15.3"
KECT-10	2/3-jacketed, 10 gallon - 12 kw	180 (82)	26.3"x34.9"x17.3"
KECT-12	2/3-jacketed, 12 gallon - 12 kw	190 (86)	26.3"x36.9"x17.3"
KECT-6-L	2/3-jacketed, 6 gallon with tilt console on left side - 7.5 kw	130 (59)	22.3"x33.5"x15.3"
KECT-10-L	2/3-jacketed, 10 gallon with tilt console on left side - 12 kw	180 (82)	26.3"x34.9"x17.3"
KECT-12-L	2/3-jacketed, 12 gallon with tilt console on left side - 12 kw	190 (86)	26.3"x36.9"x17.3"



KECTC-06

### Standard Features

- Low water level cut-off and indicator
- Pressure gauge
- Temperature control
- Safety relief valve
- Type 316 stainless steel liner
- 2/3 steam jacket
- 50 PSI (345 kPa) high pressure operation for higher cooking temperature
- Integrally mounted controls
- Removable elements
- "Clean lock" to hold kettle in cooking position or 105° for ease of cleaning
- Stainless steel console and trunnion
- Water resistant construction

## Electric Counter Steam Kettles with Crank

Model Number	Description	Weight	Dimension WxHxD
KECTC-06	2/3-jacketed, 6 gallon w/crank - 7.5 kw	130 (59)	25.1"x33.5"x15.3"
KECTC-10	2/3-jacketed, 10 gallon w/crank - 12 kw	180 (82)	28.9"x34.9"x19.3"
KECTC-12	2/3-jacketed, 12 gallon w/crank - 12 kw	190 (86)	28.9"x36.0"x19.3"



KECT-6-2

### Standard Features

- Low water level cut-off and indicator
- Pressure gauge
- Solid state temperature control
- Safety relief valve
- Type 316 stainless steel liner
- 2/3 steam jacket
- 50 PSI (345 kPa) high pressure operation for higher cooking temperature
- Integrally mounted controls
- Removable elements
- "Clean lock" to hold kettle in cooking position or 105° for ease of cleaning
- Stainless steel console and trunnion
- Water resistant construction

## Twin Electric Counter Steam Kettles

Model Number	Description	Weight	Dimension WxHxD
KECT-6-2	Twin - 2/3-jacketed, 6 gallon - 7.5 kw each	130 (59)	44.4"x33.5"x15.3"
KECT-10-2	Twin - 2/3-jacketed, 10 gallon - 12 kw each	180 (82)	55.3"x34.9"x17.3"
KECT-12-2	Twin - 2/3-jacketed, 12 gallon - 12 kw each	190 (86)	55.3"x36.9"x17.3"

# Counter Kettles



KECT-20

### Standard Features

- Low water level cut-off and indicator
- Pressure gauge
- Temperature control
- Safety relief valve
- Type 316 stainless steel liner
- 2/3 steam jacket

## Electric Counter Steam Kettles

Model Number	Description	Weight	Dimension WxHxD
KECT-20	2/3-jacketed w/legs, 20 gallon (floor model) - 12 kw	225 (102)	31"x36"x24.3"



KDCT-6

### Standard Features

- Reversible tilt handle
- 316 stainless steel liner
- Steam control valve
- 10 year hemi warranty (see warranty statement for full details)

## Direct Counter Steam Kettles

Model Number	Description	Weight	Dimension WxHxD
KDCT-6	2/3 jacket, 6 gallon	44 (20)	16"x34.1"x15.1"
KDCT-10	2/3 jacket, 10 gallon	61 (28)	19.3"x33.1"x19.1"
KDCT-12	2/3 jacket, 12 gallon	70 (32)	19.3"x35.1"x19.1"
KDCT-20	2/3 jacket, 20 gallon	95 (43)	26"x42.4"x24.1"
SCV-1	Steam control valve		Standard



KGCT-12

### Standard Features

- Low water level cut-off and indicator
- Pressure gauge
- Temperature control
- Safety relief valve
- Type 316 stainless steel liner
- 50 PSI (345 kPa) high pressure operation for high cooking temperature

## Counter Gas Steam Kettle

Model Number	Description	Weight	Dimensions WxHxD
KGCT-12	Gas counter steam kettle - 12 gallon - 43k BTU	255 (116)	30"x55.8"x25.4"

Electronic ignition is standard. See page 26 for options.

# Kettle Stands



KECT-06 on  
S-24-SB



KECT-12 on  
S-30-SB



KECT-06 on  
SD-24-SB



KECT-12 on  
SD-30-SB

## Counter Steam Kettles Stands

Model Number	Description	Weight	Dimension WxHxD
S-24-SB	24" wide stand w/sliding shelf (for 6 gallon only)	45 (21)	24"x20"x21"
S-30-SB	30" wide stand w/sliding shelf	60 (28)	30"x20"x21"
SD-24-SB	24" wide stand w/drain drawer (for 6 gallon only)	50 (23)	24"x20"x21"
SD-30-SB	30" wide stand w/drain drawer	66 (30)	30"x20"x21"
SSK-2-SB	For DC kettles requires stand skirt kit to conceal plumbing	contact factory	adds 4" to height
SD-30-20E-SB	30" wide stand w/drain drawer for model KECT-20 (FACTORY INSTALLED ONLY)	75 (34)	31.38"x26"x21"



KECT-6-2 on  
SD-48-SB



KECT-12-2 on  
SD-54-SB

## Twin Counter Steam Kettles Stands

Model Number	Description	Weight
SD-48-SB	48" wide twin kettle stand (EC-6TW-2)	110 (50)
SD-54-SB	54" wide twin kettle stand (EC-10,12TW-2)	142 (19)

# Kettle Stands



KT-30-SB

## Counter Steam Kettle Table

Model Number	Description	Weight
KT-26-SB	26" wide kettle table	140 (64)
KT-30-SB	30" wide kettle table	150 (68)
KT-40-SB	40" wide kettle table	200 (91)
KT-50-SB	50" wide kettle table	225 (102)
KT-64-SB	64" wide kettle table	285 (130)
KT-72-SB	72" wide kettle table	315 (143)
KT-80-SB	80" wide kettle table	345 (157)

## Kettle Table Options and Accessories

Model Number	KT Table Options & Accessories	Weight
SF-12EX	Single pantry faucet and extension with 12" spout	contact factory
DF-12EX	Double pantry faucet and extension with 12" spout	contact factory
DMF-6R	Deck mount dual pantry faucet and extension 6" spout	contact factory
DMF-12R	Deck mount dual pantry faucet and extension 12" spout	contact factory
DSIK-2	Direct steam interconnect first two kettles complete with steam trap, safety relief valve, and interconnect plumbing	contact factory
DSIK-1	Each additional kettle add	contact factory

# Gas Steam Kettles



KSLG-60E

## Standard Features

- 316 Stainless Steel liner
- Spring assist cover
- 2" tangent draw-off
- Flanged feet
- Electronic Ignition
- TPS strainer
- Faucet bracket
- 10 year hemi warranty (see warranty statement for full details)

## Stationary Gas Steam Kettle - Tri-Leg

Model Number	Description	Weight	Dimension WxHxD
KSLG-20	2/3 Jacketed, Gas 20 gallon - 100k BTU	440 (200)	31.25"x40"x42.5" *
KSLG-30	2/3 Jacketed, Gas 30 gallon - 100k BTU	575 (261)	35.5"x39.8"x41.5" *
KSLG-40	2/3 Jacketed, Gas 40 gallon - 100k BTU	600 (272)	35.5"x44"x48" *
KSLG-60	2/3 Jacketed, Gas 60 gallon - 130k BTU	720 (327)	40"x49.5"x52" *
KSLG-80	2/3 Jacketed, Gas 80 gallon - 150k BTU	950 (430)	41.6"x44.6"x63.1" *
KSLG-100	2/3 Jacket, Gas 100 gallon - 150k BTU	1100 (498)	41.6"x49.1"x63.1" *
KSLG-40F	Full-Jacketed, 40 gallon - 130k BTU	700 (318)	40"x43.5"x48" *
KSLG-60F	Full-Jacketed, 60 gallon - 150k BTU	950 (430)	42.6"x40.1"x59.6" *



KTLG-40



KTLG-80

## Standard Features

- 316 Stainless Steel liner
- Three piece console cover for faucet
- Flanged feet
- Electronic Ignition
- High efficiency power burner
- 10 year hemi warranty (see warranty statement for full details)
- Power tilt for 80 and 100 gallon models. Manual crank tilt for all others.

## Tilting Twin Console Gas Steam Kettle

Model Number	Description	Weight	Dimension WxHxD
KTLG-20	2/3 Jacketed, Crank Tilt, Gas 20 gallon - 80k BTU	700 (318)	48.1"x40.1"x62.5" *
KTLG-30	2/3 Jacketed, Crank Tilt, Gas 30 gallon - 100k BTU	900 (408)	55"x37.3"x65.5" *
KTLG-40	2/3 Jacketed, Crank Tilt, Gas 40 gallon - 100k BTU	930 (422)	55"x41.5"x65.5" *
KTLG-40F	Full Jacketed, Crank Tilt, 40 gallon - 120k BTU	1100 (498)	59"x40.7"x45.8" *
KTLG-60	2/3 Jacketed, Crank Tilt, Gas 60 gallon - 120k BTU	1142 (518)	58.9"x45.5"x68.5" *
KTLG-80	2/3 Jacketed, Power Tilt, Gas 80 gallon - 150k BTU	1253 (569)	60.9"x45.2"x54.6
KTLG-100	2/3 Jacketed, Power Tilt, Gas 100 gallon - 150k BTU	1403 (637)	60.9"x49.8"x54.6

\*Height of unit without cover. Dimensions may vary due to optional accessories, refer to specs for all measurements.

# Electric Steam Kettles



KELS-40

### Standard Features

- 316 Stainless Steel liner
- 2/3 Jacketed
- Spring assist cover
- 2" tangent draw-off
- TPS strainer
- Faucet bracket
- Flanged feet
- 10 year hemi warranty (see warranty statement for full details)

## Stationary Electric Steam Kettle - 2/3 Jacketed - Tri-Leg

Model Number	Description	Weight	Dimension WxHxD
KELS-20	2/3 Jacketed, 20 gallon -12 kW	196 (89)	23.75"x38"x34" *
KELS-25	2/3 Jacketed, 25 gallon -12 kW	206 (93)	25.3"x36.8"x40.1" *
KELS-30	2/3 Jacketed, 30 gallon -15 kW	226 (103)	27.8"x38"x36.5" *
KELS-40	2/3 Jacketed, 40 gallon -18 kW	255 (116)	29.8"x38"x35" *
KELS-60	2/3 Jacketed 60 gallon -18 kW	390 (177)	33.8"x42"x38.3" *
KELS-80	2/3 Jacketed, 80 gallon -18kW	445 (202)	36.8"x45"x41" *
KELS-100	2/3 Jacketed, 100 gallon -24 kW	480 (218)	40"x48"x44.5" *



KELS-60F

### Standard Features

- 316 Stainless Steel liner
- Full Jacketed
- Spring assist cover
- 2" tangent draw-off
- TPS strainer
- Faucet bracket
- Flanged feet
- 10 year hemi warranty (see warranty statement for full details)

## Stationary Electric Steam Kettle - Full Jacketed - Tri-Leg

Model Number	Description	Weight	Dimension WxHxD
KELS-20F	Full Jacketed, 20 gallon -18 kW	245 (111)	30.3"x31.3"x44"**
KELS-30F	Full Jacketed, 30 gallon -18 kW	375 (170)	33.8"x33.5"x44"*
KELS-40F	Full Jacketed, 40 gallon -18 kW	420 (191)	37"x36.3"x46.9"**
KELS-60F	Full Jacketed, 60 gallon -24 kW	460 (209)	40"x38.5"x50.4"**

\*Height of unit without cover. Dimensions may vary due to optional accessories, refer to specs for all measurements.

# Electric Steam Kettles



KEPS-40

## Standard Features

- 316 Stainless Steel liner
- 2/3 Jacketed
- Spring assist cover
- 2" tangent draw-off
- TPS strainer
- Faucet bracket
- 10 year hemi warranty (see warranty statement for full details)

## Stationary Electric Steam Kettle - 2/3 Jacketed - Pedestal

Model Number	Description	Weight	Dimension WxHxD
KEPS-20	2/3 Jacketed, 20 gallon -12 kW	196 (89)	23.8"x38"x34"**
KEPS-25	2/3 Jacketed, 25 gallon -12 kW	206 (93)	25.3"x36.8"x38"**
KEPS-30	2/3 Jacketed, 30 gallon -15 kW	226 (103)	27.8"x38"x36.5"**
KEPS-40	2/3 Jacketed, 40 gallon -18 kW	255 (116)	29.8"x38"x39"**
KEPS-60	2/3 Jacketed, 60 gallon -18 kW	390 (177)	33.8"x42"x38.3"**
KEPS-80	2/3 Jacketed, 80 gallon -18 kW	445 (202)	36.8"x45"x41"**
KEPS-100	2/3 Jacketed 100 gallon -24 kW	480 (218)	40"x48"x44.5"**



KEPS-60F

## Standard Features

- 316 Stainless Steel liner
- Full Jacketed
- Spring assist cover
- 2" tangent draw-off
- TPS strainer
- Faucet bracket
- 10 year hemi warranty (see warranty statement for full details)

## Stationary Electric Steam Kettle - Full Jacketed - Pedestal

Model Number	Description	Weight	Dimension WxHxD
KEPS-20F	Full Jacketed, 20 gallon -18 kW	245 (111)	31.3"x31.3"x44"**
KEPS-30F	Full Jacketed, 30 gallon -18 kW	375 (170)	33.5"x33.5"x44"**
KEPS-40F	Full Jacketed, 40 gallon -18 kW	425 (193)	36.3"x36.5"x47"**
KEPS-60F	Full Jacketed, 60 gallon -24 kW	460 (209)	40"x38.5"x50.4"**

\*Height of unit without cover. Dimensions may vary due to optional accessories, refer to specs for all measurements.

# Tilting Electric Steam Kettles



KELT-30

### Standard Features

- 316 Stainless Steel liner
- 2/3 Jacketed
- Faucet bracket
- Flanged feet
- Hand powered crank
- 10 year hemi warranty (see warranty statement for full details)

## Tilting Electric Steam Kettle - 2/3 Jacketed - Legs

Model Number	Description	Weight	Dimension WxHxD
KELT-20	2/3 Jacketed, 20 gallon -12 kW	296 (134)	36"x38"x37.3"*
KELT-25	2/3 Jacketed, 25 gallon -12 kW	306 (139)	36"x36.8"x37.3"*
KELT-30	2/3 Jacketed, 30 gallon -15 kW	313 (142)	39"x38"x38.3"*
KELT-40	2/3 Jacketed, 40 gallon -18 kW	352 (160)	41"x38"x43.3"*
KELT-60	2/3 Jacketed, 60 gallon -18 kW	417 (189)	44.5"x42"x46.3"*
KELT-80	2/3 Jacketed, 80 gallon -18 kW	520 (236)	48"x45"x50.8"
KELT-100	2/3 Jacketed, 100 gallon -24 kW	630 (286)	49.5"x49"x57.3"*



KELT-40F

### Standard Features

- 316 Stainless Steel liner
- Full Jacketed
- Faucet bracket
- Flanged feet
- Hand powered crank
- 10 year hemi warranty (see warranty statement for full details)

## Tilting Electric Steam Kettle - Full Jacketed - Legs

Model Number	Description	Weight	Dimension WxHxD
KELT-20F	Full Jacketed, 20 gallon -18 kW	340 (154)	40.4"x31.4"x33.4"*
KELT-30F	Full Jacketed, 30 gallon -18 kW	402 (182)	43.4"x33.5"x37"*
KELT-40F	Full Jacketed, 40 gallon -18 kW	500 (227)	47.1"x36.3"x40"*
KELT-60F	Full Jacketed, 60 gallon -24 kW	610 (277)	50"x39.5"x42.6"*

\*Height of unit without cover. Dimensions may vary due to optional accessories, refer to specs for all measurements.

# Direct Steam Kettles



KDLS-80

### Standard Features

- 316 Stainless Steel liner
- 2/3 Jacketed
- Spring assist cover
- 2" tangent draw-off
- TPS strainer
- Faucet bracket
- Flanged feet
- 10 year hemi warranty (see warranty statement for full details)

## Stationary Direct Steam Kettle - 2/3 Jacketed - Legs

Model Number	Description	Weight	Dimension WxHxD
KDLS-20	2/3 Jacketed, 20 gallon	155 (70)	22.75"x37"x30" *
KDLS-30	2/3 Jacketed, 30 gallon	180 (82)	25.9"x37"x32.8" *
KDLS-40	2/3 Jacketed, 40 gallon	190 (86)	27.9"x37"x35" *
KDLS-60	2/3 Jacketed, 60 gallon	265 (120)	31.4"x40.5"x35" *
KDLS-80	2/3 Jacketed, 80 gallon	308 (140)	34.8"x42.5"x38.8" *
KDLS-100	2/3 Jacketed 100 gallon	360 (163)	37.3"x44.5"x40" *
KDLS-125	2/3 Jacketed 125 gallon	425 (193)	44"x43.8x49.5*
KDLS-150	2/3 Jacketed, 150 gallon	465 (211)	44"x48"x56.4" *



KDLS-40F

### Standard Features

- 316 Stainless Steel liner
- Full Jacketed
- Hinged cover
- 2" tangent draw-off
- TPS strainer
- Faucet bracket
- Flanged feet
- 10 year hemi warranty (see warranty statement for full details)

## Stationary Direct Steam Kettle - Full Jacketed - Legs

Model Number	Description	Weight	Dimension WxHxD
KDLS-20F	Full Jacketed, 20 gallon	175 (79)	27.5"x37"x37.5" *
KDLS-30F	Full Jacketed, 30 gallon	240 (109)	31"x37"x41.3" *
KDLS-40F	Full Jacketed, 40 gallon	280 (127)	34.5"x37x45" *
KDLS-60F	Full Jacketed, 60 gallon	320 (145)	37"x40.5"x45.8" *
KDLS-80F	Full Jacketed, 80 gallon	380 (172)	42"x40.5"x56.4" *

\*Height of unit without cover. Dimensions may vary due to optional accessories, refer to specs for all measurements.

# Direct Steam Kettles



KDPS-30

### Standard Features

- 316 Stainless Steel liner
- 2/3 Jacketed
- Spring assist cover
- 2" tangent draw-off
- TPS strainer
- Faucet bracket
- 10 year hemi warranty (see warranty statement for full details)

## Stationary Direct Steam Kettle - 2/3 Jacketed - Pedestal

Model Number	Description	Weight	Dimension WxHxD
KDPS-20	2/3 Jacketed, 20 gallon	155 (70)	22.8"x37"x30" *
KDPS-30	2/3 Jacketed, 30 gallon	180 (82)	25.9"x37"x32.8" *
KDPS-40	2/3 Jacketed, 40 gallon	190 (86)	27.9"x37"x35" *
KDPS-60	2/3 Jacketed, 60 gallon	265 (120)	31.4"x40.5"x35" *
KDPS-80	2/3 Jacketed, 80 gallon	308 (140)	34.8"x42.5"x38.8" *
KDPS-100	2/3 Jacketed, 100 gallon	360 (163)	37.3"x44.5"x40" *



KDPS-40F

### Standard Features

- 316 Stainless Steel liner
- Full Jacketed
- Hinged cover
- 2" tangent draw-off
- TPS strainer
- Faucet bracket
- 10 year hemi warranty (see warranty statement for full details)

## Stationary Direct Steam Kettle - Full Jacketed - Pedestal

Model Number	Description	Weight	Dimension WxHxD
KDPS-20F	Full Jacketed, 20 gallon	175 (79)	27.5"x37"x37.8" *
KDPS-30F	Full Jacketed, 30 gallon	240 (109)	31"x37"x41.3" *
KDPS-40F	Full Jacketed, 40 gallon	280 (127)	34.5"x37"x45" *
KDPS-60F	Full Jacketed, 60 gallon	320 (145)	37"x40.5"x45.8" *
KDPS-80F	Full Jacketed, 80 gallon	380 (172)	43.9"x40.5"x56.4" *

\*Height of unit without cover. Dimensions may vary due to optional accessories, refer to specs for all measurements.

# Direct Steam Kettles



KDLT-80

### Standard Features

- 316 Stainless Steel liner
- 2/3 Jacketed
- Console mounted steam inlet valve
- Faucet bracket
- Hand powered crank
- Flanged feet
- 10 year hemi warranty (see warranty statement for full details)

## Tilting Direct Steam Kettle - 2/3 Jacketed - Legs

Model Number	Description	Weight	Dimension WxHxD
KDLT-20	2/3 Jacketed, 20 gallon	240 (109)	34.8"x37"x41" *
KDLT-30	2/3 Jacketed, 30 gallon	285 (129)	37.8"x37"x42.5" *
KDLT-40	2/3 Jacketed, 40 gallon	332 (151)	39.8"x37"x45" *
KDLT-60	2/3 Jacketed, 60 gallon	356 (166)	43.3"x40.5"x48.5" *
KDLT-80	2/3 Jacketed, 80 gallon	424 (192)	46.8"x42.5"x52.5" *
KDLT-100	2/3 Jacketed, 100 gallon	480 (218)	49.3"x42.5"x60.8" *



KDLT-40F

### Standard Features

- 316 Stainless Steel liner
- Full Jacketed
- Console mounted steam inlet valve
- Faucet bracket
- Hand powered crank
- Flanged feet
- 10 year hemi warranty (see warranty statement for full details)

## Tilting Direct Steam Kettle - Full Jacketed - Legs

Model Number	Description	Weight	Dimension WxHxD
KDLT-20F	Full Jacketed, 20 gallon	320 (145)	34.8"x37"x31" *
KDLT-30F	Full Jacketed, 30 gallon	350 (159)	37.8"x37"x37" *
KDLT-40F	Full Jacketed, 40 gallon	405 (184)	39.8"x37"x37" *
KDLT-60F	Full Jacketed, 60 gallon	460 (209)	43.3"x40.5"x41" *

\*Height of unit without cover. Dimensions may vary due to optional accessories, refer to specs for all measurements.

# Direct Steam Kettles



KDPT-20

### Standard Features

- 316 Stainless Steel liner
- 2/3 Jacketed
- Console mounted steam inlet valve
- Faucet bracket
- Hand powered crank
- 10 year hemi warranty (see warranty statement for full details)

## Tilting Direct Steam Kettle - 2/3 Jacketed - Pedestal

Model Number	Description	Weight	Dimension WxHxD
KDPT-20	2/3 Jacketed, 20 gallon	230 (104)	34.8"x37"x41" *
KDPT-30	2/3 Jacketed, 30 gallon	275 (125)	37.8"x37"x43" *
KDPT-40	2/3 Jacketed, 40 gallon	320 (145)	39.8"x37"x45" *
KDPT-60	2/3 Jacketed, 60 gallon	350 (159)	43"x40.5"x48" *
KDPT-80	2/3 Jacketed, 80 gallon	410 (186)	46.5"x42.5"x44" *

# Direct Steam Kettles



DMT-40S

## Tilting Modular Direct Steam Kettle - 2/3 Jacketed

### Standard Features

- 316 Stainless Steel liner
- 2/3 Jacketed
- Console mounted steam inlet valve
- Faucet bracket
- Hydraulic lift
- Flanged feet
- 10 year hemi warranty (see warranty statement for full details)

Model Number	Description	Weight	Dimension WxHxD
DMT-30S	2/3 Jacketed, 30 gallon -36" cabinet	475 (215)	36"x41.5"x33"
DMT-40S	2/3 Jacketed, 40 gallon -36" cabinet	525 (239)	36"x42.5"x33"
DMT-60S	2/3 Jacketed, 60 gallon -42" cabinet	600 (273)	42"x47.62"x33"
DMS-30S	2/3 Jacketed, 30 gallon	375 (170)	36"x41.5"x33"
DMS-40S	2/3 Jacketed, 40 gallon	400 (181)	36"x42.5"x33"
DMS-60S	2/3 Jacketed, 60 gallon	500 (227)	42"x47.62"x33"



KDLT-40TC

### Standard Features

- 316 Stainless Steel liner
- 2/3 Jacketed
- Console mounted steam inlet valve (right side)
- 3-piece split cover for optional faucet bracket
- Hand powered crank
- Flanged feet
- 10 year hemi warranty (see warranty statement for full details)

## Tilting Twin Console Direct Steam Kettle - 2/3 Jacketed - Legs

Model Number	Description	Weight	Dimension WxHxD
KDLT-20TC	2/3 Jacketed, 20 gallon	Contact Factory	46"x35.3"x36.9"
KDLT-30TC	2/3 Jacketed, 30 gallon	Contact Factory	49"x35.3"x38.6"
KDLT-40TC	2/3 Jacketed, 40 gallon	Contact Factory	51.1"x37.1"x39.5"
KDLT-60TC	2/3 Jacketed, 60 gallon	Contact Factory	54.4"x42.1"x41.1"
KDLT-80TC	2/3 Jacketed, 80 gallon	Contact Factory	57.9"x45"x43.3"
KDLT-100TC	2/3 Jacketed, 100 gallon	Contact Factory	60.3"x47.1"x44.6"

\*Height of unit without cover. Dimensions may vary due to optional accessories, refer to specs for all measurements.

# Short Tilting Kettle

## Gas Floor Kettles

Tilting floor kettles are perfect for preparing a large amount of food. Kettles are designed to be tilted past 90° for making complete emptying as easy as possible.



FT-40GLS-SB

## Standard Features

- Short-height kettle (FT-40GLS) has a height of 36 inches for improved ergonomics
- Rated for operation to 50 PSI
- Optional spring assist hinged cover
- Electric ignition, pressure gauge, safety valve and high/low water cut-off
- Six foot cord and 3 prong plug
- Tilting mechanism is self locking positive stop action will allow the kettle to tilt past 90° for complete emptying
- Optional draw-off valves available

## 2/3 Jacketed, Gas, Ergonomic Short Height Tilting Kettle

Model Number	Description	Weight	Dimension WxHxD
FT-40GLS-SB	40 gallon, gas, short height, quad leg tilting kettle - 125,000	987 (448)	52"x38"x52"

## Options and Accessories

Model Number	Description
SF-18	Single pantry faucet with swing spout
DF-18	Double pantry faucet with swing spout
SP-KF-GK	Single pantry kettle filler
DP-KF-GK	Double pantry kettle filler
TVT-2	2" Tangent Draw-Off Valve, for Tilting Kettles
TVT-3	3" Tangent Draw-Off Valve, for Tilting Kettles
GM-40	Etched gallon markings
LM-151	Etched litre markings
TKS-40G	Lip strainer
SH	Strainer hook
CH-40	Spring assist stainless steel cover
TBA-40G	Tri-basket assembly
CMS-40	Graduated measuring strip

# Modular Base Tilting Kettles

## Electric Large Capacity Kettles

This stainless steel cabinet base electric steam kettle is capable of BIG things. Tilting type shall tilt nearly upright to allow complete emptying of contents under positive control by turning removable crank. Tilting may be stopped at any time without kettle settling back.



MT-40EO-SB

### Standard Features

- Water Treatment System
- Available in 25 and 40 gallon capacity
- 2/3 jacketed, type 316 stainless steel liner
- Automatic fill and cold water condenser system
- All stainless steel, equipped with easy-to-clean cover, sanitary draw-off valve with removable strainer, removable swing drain and hot and cold water fill faucets
- Easy transfer of foods with exclusive Southbend pan support that positions pan just below kettle lip throughout tilting operation
- Modular cabinets enclose kettle, steam pipes, safety valve, low water cut-off, sight gauge and pressure gauge
- 4 flanged adjustable 6" stainless steel legs counter-balanced lid with insulated knob
- Comes with standard manual tilt or optional power tilt
- ASME certified boiler is self contained within modular base

## Large Capacity Electric Modular Base Kettles

Model Number	Description	Weight	Dimension WxHxD
MT-25EO-SB	25 gallon, electric tilting kettle on modular base - 24 kW	410 (186)	36"x38"x33"
MT-40EO-SB	40 gallon, electric tilting kettle on modular base - 24 kW	430 (195)	36"x38"x33"

## Options and Accessories

Model Number	Description
MT-PT	Optional Power Tilt
TKS-25MT	For MT-25EO-SB MF kettle
TKS-40MT	For MT-40EO-SB MF kettle



## DON'T COOK WITHOUT YOUR JACKET

Steam is generated in the kettle jacket and used to heat the product gently, keeping a constant temperature and never burning or scorching - just great results every time!

# Electric Mixing Kettles



KEMTL-40

### Standard Features

- 316 Stainless Steel liner
- 2/3 Jacketed
- Hydraulic power tilt bridge
- Flanged feet
- 10 year hemi warranty (see warranty statement for full details)

## Electric Leg-Mounted Tilting Mixer Kettle

Model Number	Description	Weight	Dimensions WxHxD
KEMTL-40	Single - 40 gallon - 24kW	830 (377)	62.3"x75.6"x38.3"
KEMTL-60	Single - 60 gallon - 24kW	880 (400)	66"x80"x38.25"
KEMTL-80	Single - 80 gallon - 24kW	1050 (477)	69.3"x80"x38.3"
KEMTL-100	Single - 100 gallon - 24kW	1295 (568)	71.5"x85"x38.25"
KEMTL-40-2	Double - 40 gallon - 24kW + 24kW	1600 (727)	102"x75.6"x38.3"
KEMTL-60-2	Double - 60 gallon - 24kW + 24kW	1650 (705)	108"x80"x38.25"
KEMTL-80-2	Double - 80 gallon - 24kW + 24kW	1850 (840)	116"x80"x38.25"
KEMTL-100-2	Double - 100 gallon - 24kW + 24kW	2150 (975)	121"x85"x38.25"

# Direct Steam Mixing Kettles

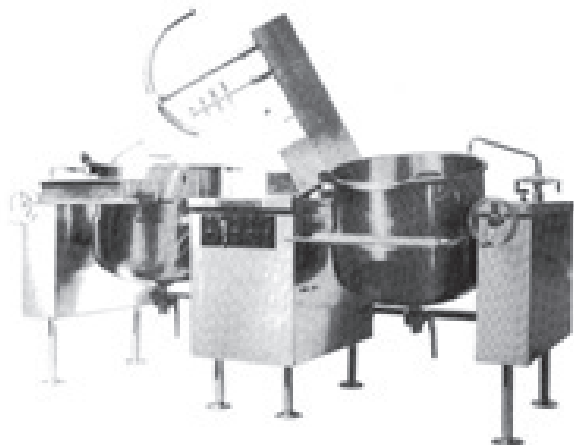

KDMTL-40-2

## Standard Features

- 316 Stainless Steel liner
- 2/3 Jacketed
- Hydraulic power tilt bridge
- Flanged feet
- 35 PSI
- 10 year hemi warranty (see warranty statement for full details)

## Direct Steam Leg Mounted Tilting Mixer Kettles

Model Number	Description	Weight	Dimensions WxHxD
KDMTL-40	40 gallon	700 (318)	62"x75.6"x38.3"
KDMTL-60	60 gallon	730 (331)	65"x80"x38.3"
KDMTL-80	80 gallon	840 (381)	67.8"x80"x38.3"
KDMTL-100	100 gallon	900 (410)	70"x85"x38.3"
KDMTL-40-2	40 gallon	1350 (613)	102"x75.6"x38.3"
KDMTL-60-2	60 gallon	1400 (636)	108"x80"x38.3"
KDMTL-80-2	80 gallon	1490 (677)	116"x80"x38.3"
KDMTL-100-2	100 gallon	1595 (725)	121"x80"x38.3"

## Steam Kettle Options and Accessories

Model Number	Description
	<b>Contour Measuring Strips</b>
CMS	6-150 gallons or liters (SPECIFY)
	<b>Permanent Etched Gallon Markings</b>
GM-6	Kettle size 6 gal. (For liters us option LM-23-SB)
GM-10	Kettle size 10 gal. (For liters us option LM-38-SB)
GM-12	Kettle size 12 gal. (For liters us option LM-45-SB)
GM-20	Kettle size 20 and 25 gal. (For liters us option LM-76-SB or LM-95-SB)
GM-30	Kettle size 30 gal. (For liters us option LM-114-SB)
GM-40	Kettle size 40 gal. (For liters us option LM-151-SB)
GM-60	Kettle size 60 gal. (For liters us option LM-227-SB)
GM-80	Kettle size 80 gal. (For liters us option LM-303-SB)
GM-100	Kettle size 100 gal. (For liters us option LM-379-SB)
	<b>Steam Control Options, Tilting &amp; Stationary Kettles</b>
STA-1	Steam control assembly consisting of line strainer, steam inlet globe, steam trap, and check valve (KDLS & KDPS kettles)
STA-2	Steam control assembly consisting of line strainer (KDLT & KDPT Kettles)
STA-3	Line Strainer, steam trap, 50 PSI safety valve (KDCT kettles)
STA-4	Line Strainer, steam trap, 15 PSI safety valve (TOC-SB kettles)
PRV-2	Pressure regulating valve (20-60 PSI)
HP-35	35 PSI direct steam kettle model KDLS/KDPS-80F
HP-50	50 PSI direct steam kettle model 20 to 100 gallon
QCS-1	Quick chill system for direct steam kettles twin console only 20-100 gallon

## Mixer Kettle Options and Accessories

Model Number	Description
BV-2	2" manual butterfly valve
BV-3	3" manual butterfly valve
BVE90-2	90° elbow with flange connections, 1 clamp & gasket (must order BV-2)
BVE90-3	90° elbow with flange connections, 1 clamp & gasket (must order BV-3)
MKS	Mixer kettle strainer
MKSS	Mixer kettle solid strainer
MC-40	Mixer kettle cover - 2 pc lift off - 40 gallon
MC-60	Mixer kettle cover - 2 pc lift off - 60 gallon
MC-80	Mixer kettle cover - 2 pc lift off - 80 gallon
MC-100	Mixer kettle cover - 2 pc lift off - 100 gallon
MMO-1	380/3/50 (5 HP motor) * must also order EKVS-1-SB with this option
MMO-2	415/3/50 (5 HP motor) * must also order EKVS-1-SB with this option
MMO-3	480/3/60 (5 HP motor) * must also order EKVS-2-SB with this option
MMO-4	575/3/60 or 600/3/60 (5 HP motor) * must also order EKVS-3-SB with this option

## Steam Kettle &amp; Braising Pan Options and Accessories

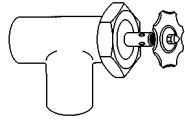
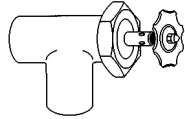
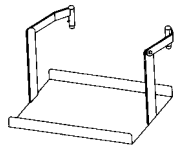
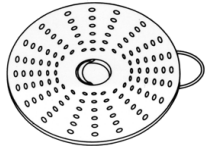
Model Number	Description	
<b>Tangent Draw-off Valve - Stationary Kettles</b>		
TVS-3	3" in lieu of standard 2" with strainer	
<b>Tangent Draw-off Valve - Tilting Kettles</b>		
TVT-2	2" Valve with strainer added to tilting kettle	
TVT-3	3" Valve with strainer added to tilting kettle	
<b>Dairy Draw Off Valve</b>		
DDO-3S	3" Dairy draw off valve (stationary kettle)	
DDO-3T	3" Dairy draw off valve (tilting kettle)	
<b>Draw Off Valve Options</b>		
DVDC-1	Draw valve, drain cup assembly	
DFC-2	Draw off valve flange connector 2"	
DFC-3	Draw off valve flange connector 3"	
DVHK-1	1-1/2" drain valve hose kit	
DVHK-2	2" drain valve hose kit	
DVHK-3	3" drain valve hose kit	
<b>Pan Support - Tilting Kettles</b>		
PC-4	20-100 gallons	
<b>Tangent Draw-off Valve Strainers - (1) TPS standard with TVT</b>		
TPS-2	Perforated strainer for 2" draw-offs	
TPS-3	Perforated strainer for 3" draw-offs	
SH	Strainer hook	

## Gas Kettle Options

Model Number	Description
GKVS-1	220 or 240/1/50 or 60 Hz controls (SPECIFY)
C-12G	Lift off cover 12 gallon gas kettle
SD-30-12G	KGCT-12 support stand with sliding drawer or rollers, splash diffuser and drain (FACTORY INSTALLED ONLY)

## Electric Kettle Options and Accessories

Model Number	Description
EKVS-0-SB	380/220 or 415/240, 3-phase, 50 or 60 Hz, 4 wire
EKVS-1-SB	380 or 415 volts, 50 or 60 Hz, 3-phase
EKVS-2-SB	440, 460 or 480 volts, 60 Hz, 3-phase
EKVS-3-SB	575 or 600 volts, 60 Hz, 3-phase
EK-24-SB	24 kW elements (recommended for large kettles 40, 60, 80, 100)
EK-33-SB	33 kW elements (recommended for large kettles 60, 80, 100)
SST-E-SB	Solid State Thermostat for Electric kettles EL, EP, ELT and EC-20T
HTC-SB	Export heat-treat crating (per unit)

## Faucets

Model Number	Descriptions
FB-SB	Faucet bracket only
SF-12-SB	12" single pantry faucet
DF-12-SB	12" double pantry faucet
SF-18-SB	18" single pantry faucet
DF-18-SB	18" double pantry faucet
DF-18-3/4-SB	18" double pantry faucet for Marine Kettles
DMF-18R-SB	18" deck mounted faucet and extension
SP-KF-SB	Single pantry kettle filler
DP-KF-SB	Double pantry kettle filler
SP-KF-GK-SB	Single pantry kettle filler for gas kettles
DP-KF-GK-SB	Double pantry kettle filler for gas kettles
SF-18-DJ-SB	Single pantry faucet with 'dual joint' 18" swing spout model for use on KECT-6,10,12-2 twin kettle
DF-18-DJ-SB	Double pantry faucet with 'dual joint' 18" swing spout model for use on KECT-6,10,12-2 twin kettle
SP-RSH-SB	Single pantry rinse spray head with 68" hose
DP-RSH-SB	Double pantry rinse spray head with 68" hose
DP-RSH-6-SB	Double pantry faucet with 6" swing spout, rinse spray head and 68" hose
SF-RSH-12-SB	Single pantry faucet with 12" swing spout, rinse spray head and 68" hose
DF-RSH-12-SB	Double pantry faucet with 12" swing spout, rinse spray head and 68" hose
SF-RSH-18-SB	Single pantry faucet with 18" swing spout, rinse spray head and 68" hose
DF-RSH-18-SB	Double pantry faucet with 18" swing spout, rinse spray head and 68" hose
BFP-S-SB	Back flow preventer for single pantry faucet
BFP-D-SB	Back flow preventer for double pantry faucet

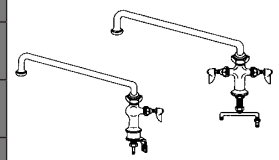

Steam Kettle Options and Accessories

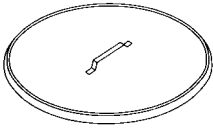
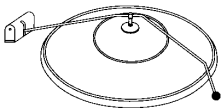
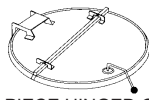
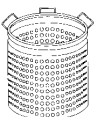
Model Number	Description	
SARM-SB	Spring assist rear mount	
C-6-SB	6 gal.	 <p>LIFT OFF COVER</p>
C-10-SB	10 gal.	
C-12-SB	12 gal.	
C-20-SB	20 gal.	
C-25-SB	25 gal.	
C-30-SB	30 gal.	
C-40-SB	40 gal.	
C-60-SB	60 gal.	
C-80-SB	80 gal.	
C-100-SB	100 gal.	
C-20F-SB	20 gal. - Full jacket	
C-30F-SB	30 gal. - Full jacket	
C-40F-SB	40 gal. - Full jacket	
C-60F-SB	60 gal. - Full jacket	
LCH-1-SB	Lift off cover holder 6,10,12, and 20 gal	
CH-20-SB	20 gal.	 <p>SPRING ASSIST COVER</p>
CH-25-SB	25 gal.	
CH-30-SB	30 gal.	
CH-40-SB	40 gal.	
CH-60-SB	60 gal.	
CH-80-SB	80 gal.	
CH-100-SB	100 gal.	
CH-20F-SB	20 gal. - Full jacket	
CH-30F-SB	30 gal. - Full jacket	
CH-40F-SB	40 gal. - Full jacket	
CH-60F-SB	60 gal. - Full jacket	
CR-1-SB	Condensate Ring - factory installed	
2PHC-40-SB	40 gal.	 <p>TWO PIECE HINGED COVER</p>
2PHC-60-SB	60 gal.	
2PHC-80-SB	80 gal.	
2PHC-100-SB	100 gal.	
2PHC-20F-SB	20 gal. - Full jacket	
2PHC-30F-SB	30 gal. - Full jacket	
2PHC-40F-SB	40 gal. - Full jacket	
2PHC-60F-SB	60 gal. - Full jacket	
<b>Single, Perforated Stainless Steel Basket</b>		
SSB-6-SB	6 gal.	
SSB-10-SB	10 gal.	
SSB-12-SB	12 gal.	
SSB-20-SB	20 gal.	
SSB-25-SB	25 gal.	

## Steam Kettle Options and Accessories

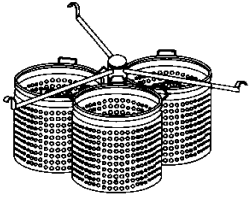
Model Number	Description
<b>Triple, Perforated Stainless Steel Basket Assembly (2/3 jacketed kettle)</b>	
TBA-20-SB	20 gallon
TBA-25-SB	25 gallon
TBA-30-SB	30 gallon
TBA-40-SB	40 gallon
TBA-60-SB	60 gallon
TBA-80-SB	80 gallon
TBA-100-SB	100 gallon
	
<b>Kettle Strainers</b>	
TKS-6-SB	6 gallon kettle
TKS-10-SB	10 gallon kettle
TKS-12-SB	12 gallon kettle
TKS-20-SB	20 gallon kettle
TKS-25-SB	25 gallon kettle
TKS-30-SB	30 gallon kettle
TKS-40-SB	40 gallon kettle
TKS-60-SB	60 gallon kettle
TKS-80-SB	80 gallon kettle
TKS-100-SB	100 gallon kettle
TKS-20F-SB	20 gallon – Full Jacket
TKS-30F-SB	30 gallon – Full Jacket
TKS-40F-SB	40 gallon – Full Jacket
TKS-60F-SB	60 gallon – Full Jacket
<b>Gas Kettle Strainers</b>	
TKS-20G-SB	20 gallon gas kettle
TKS-30G-SB	30 gallon gas kettle
TKS-40G-SB	40 gallon gas kettle
TKS-60G-SB	60 gallon gas kettle
<b>Brush and Paddle Kit</b>	
KBPK-1-SB	Kettle brush paddle kit, 4 piece (36" clean up brush, 36" paddle, draw off brush, hand held scrub brush)
KBUK-1-SB	Kettle brush utensil kit, 6 piece (36" clean up brush, 36" paddle, draw off brush, hand held scrub brush, 36" S/S wisp, 24oz S/S ladle)
<b>Reinforced Rim</b>	
P-RBR-SB	Reinforced bar rim
<b>Kettle Heat Shields</b>	
KHS-20-SB	Kettle Heat Shield for 20 gallon kettle
KHS-25-SB	Kettle Heat shield for 25 gallon kettle
KHS-30-SB	Kettle Heat shield for 30 gallon kettle
KHS-40-SB	Kettle Heat shield for 40 gallon kettle
KHS-60-SB	Kettle Heat shield for 60 gallon kettle
KHS-80-SB	Kettle Heat shield for 80 gallon kettle
KHS-100-SB	Kettle Heat shield for 100 gallon kettle

# Tilting Skillets

---

## Gas Floor Model Tilt Skillets

---

<b>What size Skillet is right for you?</b>	
Meals per Hour	Suggested Skillet Size
100-350	One 30 gallon pan
351-500	One 40 gallon pan
501-750	Two 30 gallon pans
751-1,000	Two 40 gallon pans

# Tilt Skillets



BGLT-40

### Standard Features

- 304 Stainless Steel liner
- Manual tilt
- Pour strainer
- 4" vent port
- Etched gallon markings
- Flanged feet
- Electronic ignition (gas models)

## Electric & Gas Floor Tilting Skillets - Manual Tilt

Model Number	Description	Weight	Dimension WxHxD
BECT-30	Electric floor skillet, 30 gal. 18kW	501 (228)	49.8"x67.6"x43.5" *
BECT-40	Electric floor skillet, 40 gal. 27kW	547 (248)	59"x67.5"x43.5" *
SCK-1-SB	4" Swivel Casters, set of (4) - factory installed only		
<b>Voltage:</b>			
GSVS-1-SB	220 VAC, 50/60 Hz, 1-phase (for gas units)		
ESVS-0-SB	220/380 VAC, 50 or 60 Hz, 3-phase - 4-wire; 240/415 VAC, 50 or 60 Hz, 3-phase - 4-wire		
ESVS-1-SB	380 or 415 VAC, 50/60 Hz, 3-phase;		
ESVS-2-SB	440, 460 or 480 VAC, 50/60 Hz, 3-phase;		
ESVS-3-SB	575 or 600 volts, 50 or 60 Hz, 3-phase		



BELTS-40

### Standard Features

- 304 Stainless Steel liner
- Power tilt
- Pour strainer
- 4" vent port
- Etched gallon markings
- Flanged feet (rear)
- Electronic ignition (gas models)

## Electric & Gas Floor Tilting Skillets - Electric Tilt

Model Number	Description	Weight	Dimension WxHxD
BELTS-40	40 gallon electric open base tilt skillet with electric tilt - 18kW	575 (260)	48"x74"x33"
BGLTS-30	30 gallon gas open base tilt skillet with electric tilt* - 80,000 BTU	550 (249)	36"x70"x33"

\*Dimensions may vary due to optional accessories, refer to specs for all measurements.



# Tilt Skillets



BELM-30



BGLM-40N

### Standard Features

- 304 Stainless Steel liner
- Manual tilt
- Pour strainer
- 4" vent port
- Etched gallon markings
- Flanged feet (rear)
- Electronic ignition (gas models)

## Electric & Gas Floor Tilting Skillets - Manual Tilt

Model Number	Description	Weight	Dimension WxHxD
BELM-30	30 gallon - 12 kW Electric, manual tilting skillet	545 (247)	36"x71.4"x38.9"
BELM-40	40 gallon - 18 kW Electric, manual tilting skillet	710 (322)	48"x70.9"x39.4"
BGLM-30	30 gallon - 100,000 BTU Gas, manual tilting skillet	550 (250)	36"x71.4"x38.9"
BGLM-40	40 gallon - 125,000 BTU Gas, manual tilting skillet	720 (327)	48"x70.9"x39.4"
BGLM-40N	40 gallon - 100,000 BTU Gas, manual tilting skillet - Narrow	720 (327)	36"x75.50"x39.5"
BGLM-40N	60 gallon - 125,000 BTU Gas, manual tilting skillet - Narrow	755 (342)	48"x77.03"x40.88"



BGMTS-60

### Standard Features

- 304 Stainless Steel liner
- Hydraulic tilt
- Pour strainer
- 4" vent port
- Etched gallon markings
- Flanged feet
- Electronic ignition (gas models)

## Electric & Gas Modular Tilting Skillets - Hydraulic Tilt

Model Number	Description	Weight	Dimension WxHxD
BEMTS-30	30 gallon - 12 kW Electric, with electric tilt	617 (280)	36"x70.9"x39.5"
BEMTS-40	40 gallon - 18 kW Electric, with electric tilt	770 (349)	48"x70.9"x39.5"
BEMTS-60	60 gallon - 27 kW Electric, with electric tilt	845 (383)	48"x77.5"x46.50"
BGMTS-30*	30 gallon - 80,000 BTU Gas, with electric tilt	650 (295)	36"x70.9"x39.5"
BGMTS-40*	40 gallon - 100,000 BTU Gas, with electric tilt	825 (374)	48"x70.9"x39.5"
BGMTS-60*	60 gallon 100,000 BTU Gas, with electric tilt	900 (408)	48"x77.5"x46.50"

\*Dimensions may vary due to optional accessories, refer to specs for all measurements.

# Tilting Skillets

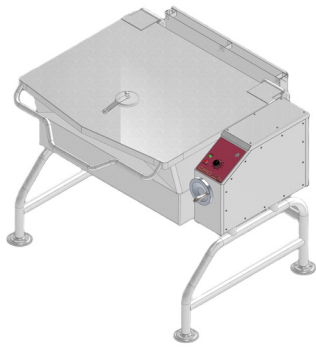

SKG-40-SB

### Standard Features

- 304 Stainless Steel liner
- Manual or optional power tilt
- Redundant safety systems
- All Stainless-Steel exterior
- IPX6 water-resistant console
- Etched gallon markings
- Covered corners - for ease of cleaning

## NEW! Gas Floor Tilting Skillets - Manual or Power Tilt

Model Number	Description	Weight	Dimension WxHxD
SKG-30-SB	Gas floor skillet, 30 gal. 110,000 BTU	360 (163)	38.6"x71.6"x41.2"
SKG-40-SB	Gas floor skillet, 40 gal. 156,000 BTU	450 (204)	48.6"x71.6"x41.2"



BECT-12



BGCTS-16



ECTRS-16S  
(on optional stands)

### Standard Features

- 304 Stainless Steel liner (BECTS-12, ECTRS-16S)
- 316 Stainless Steel liner (BGCTS-16)
- Manual tilt
- Pour strainer
- 4" vent port
- Etched gallon markings
- Electronic ignition (gas models)

## Counter Tilting Skillets - Electric and Gas

Model Number	Description	Weight	Dimension
BECT-12	Counter skillet, 12 gal. 9kW	191 (87)	29.25"x34.13"x26.5"
ECTRS-16S	16 gallon electric counter tilt skillet - 7.5kW	220 (100)	29"x38.75"x33.1"
BGCTS-16	16 gallon gas counter tilt skillet - 63,000 BTU	290 (132)	30.63"x40.1"x30.75"

## Counter Skillets Optional Stands

Model Number	Description	Weight
S-30-SB	30" wide stand with sliding shelf (BECTS-12, ECTRS-16S)	45 (21)
SD-30-SB	30" wide stand with drain drawer (BECTS-12)	50 (23)
SD-30-16-SB	30" wide stand with drain drawer (ECTRS-16S)	55 (25)
SD-30-16S-SB	30" wide stand with drain drawer (BGCTS-16)	60 (27)



## Braising Pan and Skillet Options and Accessories

Model Number	Description
SC-12-SB	Lift-off cover for BECT-12
SC-16-SB	Lift-off cover for ECTRS-16S
SC-16S-SB	Lift-off cover for BGCTS-16
SPI-12-SB	Steam pan insert for BECT-12
SPI-16-SB	Steam pan insert for ECTRS-16S
SPI-16S-SB	Steam pan insert for BGCTS-16
SPI-30-SB	Steam pan insert for 30 gallon models
SPI-40-SB	Steam pan insert for 40 and 60 gallon models
SP-RSH-SB	Single pantry rinse spray head with 68" hose
DP-RSH-SB	Double pantry rinse spary head with 68" hose
PS-16S-SB	Stainless steel pour lip strainer for BGCTS-16
PS-12-SB	Stainless steel pour lip strainer for BECT-12
SF-12-SB	12" Single pantry faucet
DF-12-SB	12" Double pantry faucet
PC-HP-SB	Half size pan carrier (skillet with draw off for BGLM-30 and BELM-30)
PC-1-SB	Pan Carrier - BECT-30, 40 & BGLT-30, 40
PC-3-SB	Pan Carrier - BELM-30, 40 & BGLM-30,40 & BELTS-30, 40 & BGLTS-30, 40 (not available in combination with tangent draw-off valve with the BELM-30 or BGLM-30)
SPE-1-SB	3" Stainless steel plumbing enclosures (BELM/BGLM, BGLTS/BELTS, BEMTS/BGMTS)
ESVS-1-SB	380 or 415 volts, 3-phase, 50 Hz (SPECIFY)
ESVS-2-SB	440, 460 or 480 volts, 3-phase, 60 Hz (SPECIFY)
ESVS-3-SB	575 or 600 volts, 3-phase, 60 Hz (SPECIFY)
GSVS-1-SB	220/1/50 or 60 Hz control for gas skillets
TVT-2-SB	2" Tangent Draw Off Valve added to tilting skillet with strainer
FFF-2-SB	Front Flanged Feet (standard on BGMTS / BEMTS models)
FB-SB	Faucet bracket only
LMS-45-SB	Etched liter marking for BECT-12
LMS-60-SB	Etched liter marking for ECTRS/BGCTS
LMS-114-SB	Etched liter marking for 30 gallon models
LMS-151-SB	Etched liter marking for 40 gallon models
SCK-1-SB	4" all swivel casters 2 with foot brakes, set of 4 (BECT & BGLT ONLY)
MT-60-SB	60 minute mechanical timer (BECT ONLY)
DPHK-1-SB	Drain pan hose kit – must also order PC pan carrier
ESKS-12-SB	12 kw electric skillet kw specify - 12 kw for BECT-30
ESKS-18-SB	18 kw electric skillet kw specify - 18 kw for BECT-40
S-SDP-2-SB	Sliding drain pan BELM/BGLM
PC-SK-SB	Pan carrier for SKG and SKE
PS-SK-SB	Pouring lip strainer for SKG and SKE
SDP-SK-SB	Pull out sliding sink drain drawer with splash shield for SKG and SKE
PT-SK-SB	Power Tilt with hand tilt override for SKG
CK-SK-SB	Casters only for SKG skillets
CKSRH-SKG-SB	Caster kit and strain relief with gas hose for SKG

Options and Accessories

Model Number	Description
SPI-30-SB	Steam Pan Inserts 40 Gal Models
SPI-40-SB	Steam pan insert for 40 and 60 gallon models
MS-DVDC-SB	Drain Cup with 8' Hose (For 2" Draw-Off Valve)
98-4216-SB	Water Hose Kit, 60" Line w/Quick Disconnect, 3/8" NPT (1 hose per kit)
MS-SFRSH-SB	Single Pantry Faucet w/68" Rinse/Spray Hose w/nozzle & bracket
MS-DFRSH-SB	Double Pantry Faucet w/68" Rinse/Spray Hose w/nozzle & bracket
MS-SF-SB	Single Pantry Faucet, Complete (Kit; Brackets & Plumbing)
MS-DF-SB	Double Pantry Faucet, Complete (Kit; Brackets & Plumbing)
MS-SFSH-SB	Single Faucet Spray Hose (Kit; Brackets & Plumbing)
MS-DFSH-SB	Double Faucet Spray Hose (Kit; Brackets & Plumbing)
FB-SB	Faucet Bracket
MS-PC-SB	Pan Support
MS-SEISFT-SB	Seismic feet (set of 4) installed at factory only
MS-CK-SB	Casters
MS-CKSRH-SB	Casters and Strain Relief with Gas Hose
MS-SRH-SB	Gas Strain Relief with Gas Hose
MS-DOS-SB	2" Draw-Off Strainer
MS-SSHA-SB	Spring Support Hose Assembly for Spray Hose Assembly
MS-PT-SB	Power Tilt
MS-PS-SB	Lip Strainer
MS-DV-2-SB	2" Tangent Draw-Off, with Strainer
MS-DVHK-2-SB	2" Draw-Off, with Drain Kit Hose Assembly
MS-SDP-1-SB	Pull-Out Sliding Sink Drain Drawer w/Splash Shield for Open Leg Skillets (Factory installed only)
ESVS-1-SB	380 OR 415 VOLT, 3 PHASE (specify)
ESVS-2-SB	440-460-480 Volt Option for electric skillets, add
ESVS-3-SB	Export voltage upcharge
GSVS-1-SB	220v Upcharge For Gas Units
HTC-SB	Export crating - NET per/section
EKVS-2-SB	440, 460 or 480 volts, 60 Hz, 3-phase
EKVS-3-SB	575 or 600 volts, 60 Hz, 3-phase
MS-MP30-SB	Modular panels, 30 gallon model
MS-MP40-SB	Modular panels, 40 gallon model
Prison Options	
P-TPSTW-SB	Tamper proof screws & tackwelds where applicable
P-HCC-S30-SB	Hinged cover over control panel w/ locking provision-lock by others
P-HCC-S40-SB	S/s hinged cover over control panel with locking provision
P-LHC-SB	s/s locking hasp on cover - lock by others

Cord and plug are standard on all gas skillets.



MS-DVDC-SB  
Drain Cup w/Hose

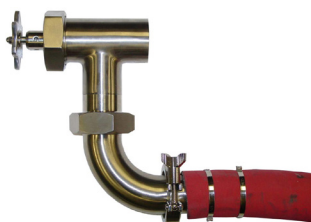

MS-DVHK-2-SB  
2" Draw-Off /Drain Kit



MS-SFRSH-SB & MS-SSHA-SB  
Single Pantry Faucet  
w/68" spray hose, and spring  
support for hose assembly



MS-DFRSH-SB & MS-SSHA-SB  
Double Pantry Faucet  
w/68" spray hose, and spring  
support for hose assembly

# Prison/Correctional Options

A full line of cooking equipment designed to meet the special needs of correctional institutions.

- **Protects against tampering:** stops unauthorized changes in settings, fit or operation.
- **Deters vandalism:** stops intentional damage designed to disrupt operation or disable equipment.
- **Eliminates safety risks:** modified to include non-removable parts, shatterproof windows and equipment floor anchors.

## Convections Ovens

Correctional fasteners .....	\$569
Door locking clasps (per oven cavity) .....	\$717
Secured light cover (per oven cavity) .....	\$155
Control panel cover (per oven cavity) .....	\$1,859
Expanded metal on flue/vent .....	\$569
Top and bottom enclosure for rear jacket (if applicable) .....	\$956

## Restaurant Range

Correctional fasteners .....	\$547
Door locking clasp .....	\$547
Knob cover .....	\$1,365

## Heavy Duty Counterline

Correctional fasteners .....	\$547
Knob cover .....	\$1,365

## Platinum

Correctional fasteners .....	\$547
Door locking clasp .....	\$547
Knob cover .....	\$1,365
Control panel cover (oven base only) .....	\$547



# Prison Options

## Direct Steam Kettles-2/3 Jacketed

Model Number	Description
P-SPDO-SB	S/S step plate over draw off valve - over tangent draw offs only (not available on tilting kettles)
P-TPSTW-SB	Tamperproof screws & tackwelds - where applicable
P-RBR-SB	Reinforced bar rim
SCCA-1-SB	Spring assist cover chain assembly c/w 12" chain with clasp
P-TDCJ-SB	"TDCJ" cover/handle - stationary kettles only – padlocks not supplied
SDC-1-SB	Swing drain collector/funnel (floor mounted with hose)
P-IKB-SB	Insulated kettle body
P-CP-1-SB	Chrome plated steam control assembly – add to sta price
P-TKFD-SB	Tilt kettle flow diverter (not available on DMT models)
P-FFMPW-SB	Flanged foot mounting plate for welding to the floor (5709-1)

## Electric Kettles-2/3 Jacketed

Model Number	Description
P-SPDO-SB	S/S step plate over draw off valve - over tangent draw offs only (not available on tilting kettles)
P-HCC-K-SB	S/S hinged cover over control panel with locking provision
P-TPSTW-SB	Tamperproof screws & tackwelds - where applicable
P-RBR-SB	Reinforced bar rim
SCCA-1-SB	Spring assist cover chain assembly c/w 12" chain with clasp
P-PGG-E-SB	Pressure gauge guard
P-TDCJ-SB	"TDCJ" cover/handle - stationary kettles only – padlocks not supplied
SDC-1-SB	Swing drain collector/funnel (floor mounted with hose)
CLH-1-SB	Change leg height – dependent on height requested
P-TKFD-SB	Tilt kettle flow diverter (not available on DMT models)
P-FFMPW-SB	Flanged foot mounting plate for welding to the floor (5709-1)

## Gas Kettles-2/3 Jacketed

Model Number	Description
P-SPDO-SB	S/S step plate over draw off valve - over tangent draw offs only (not available on tilting kettles)
P-HCC-GK-SB	S/S hinged cover over control panel with locking provision
P-TPSTW-SB	Tamperproof screws & tackwelds - where applicable
SCCA-1-SB	Spring assist cover chain assembly c/w 12" chain with clasp
P-TDCJ-SB	"TDCJ" cover/handle - stationary kettles only – padlocks not supplied
SDC-1-SB	Swing drain collector/funnel (floor mounted with hose)
CLH-1-SB	Change leg height – dependent on height requested
P-IF-1-SB	Insulated flue
P-PF-GK-SB	Perforated flue cover
P-LHC-SB	S/s locking hasp on cover – lock not supplied
P-DEC-120-SB	Direct electrical connection for 120v gas units
P-FFMPW-SB	Flanged foot mounting plate for welding to the floor (5709-1)

# Prison Options

## Skillet - Floor Models

Model Number	Description
<b>30 Gallons</b>	
P-HCC-S30-SB	S/S hinged cover over control panel with locking provision
P-TPSTW-SB	Tamperproof screws & tackwelds - where applicable
P-PF-S30-SB	Perforated flue cover
P-DEC-120-SB	Direct electrical connection for 120v gas units
P-FFMPW-SB	Flanged foot mounting plate for welding to the floor (5709-1)
<b>40 Gallons</b>	
P-HCC-S40-SB	S/S hinged cover over control panel with locking provision
P-TPSTW-SB	Tamperproof screws & tackwelds - where applicable
P-PF-S40-SB	Perforated flue cover
P-DEC-120-SB	Direct electrical connection for 120v gas units
P-FFMPW-SB	Flanged foot mounting plate for welding to the floor (5709-1)

## Pressure Cookers

Model Number	Description
P-HCC-PC-SB	S/S hinged cover over control panel with locking provision
P-CBL-1-SB	Cabinet base door with locking provision – lock not supplied
P-TPSTW-SB	Tamperproof screws & tackwelds - where applicable
P-IF-1-SB	Insulated flue cover
P-PF-BB-SB	Perforated flue cover
P-DEC-120-SB	Direct electrical connection for 120v gas units
P-FFMPW-SB	Flanged foot mounting plate for welding to the floor (5709-1)

## Pressureless Steamers

Model Number	Description
P-HCC-PS-SB	S/S hinged cover over control panel with locking provision
P-CBL-1-SB	Cabinet base door with locking provision – lock not supplied
P-TPSTW-SB	Tamperproof screws & tackwelds - where applicable
KOL-1-SB	Kettle on left-hand side of cabinet base (GCX-2S-6 models, etc.)
P-IF-1-SB	Insulated flue cover
P-PF-BB-SB	Perorated flue cover
P-DEC-120-SB	Direct electrical connection for 120v gas units
P-FFMPW-SB	Flanged foot mounting plate for welding to the floor (5709-1)

## Counter Steamers

Model Number	Description
P-TPSTW-SB	Tamperproof screws & tackwelds - where applicable
P-HCC-SX-SB	S/S hinged cover over control panel with locking provision



## Limited Warranty

Southbend warrants that the equipment, as supplied by the factory to the original purchasers, is free from defects in materials and workmanship. Should any part thereof become defective as a result of normal use within the period and limits defined below, then at the option of Southbend such parts will be repaired or replaced by Southbend or its Authorized Service Agency. This warranty is subject to the following conditions:

Repairs under this warranty are to be performed by a Southbend Authorized Service Agency. All warranty repairs must be completed utilizing Manufacturer OEM Parts. Southbend cannot be responsible for charges incurred or services performed by non-Southbend Authorized Agencies. In all cases, the closest Southbend Authorized Service Agency must be used.

### TIME PERIOD:

One year labor, one year parts effective from the date of original purchase. The authorized service agency will require proof of purchase before performing warranty repairs.

Heavy Duty Sectional: One year on operational parts, one year labor.

Gold Convection Oven: One year on operational parts, one year labor.

Silverstar Convection Oven: One year on operational parts, one year labor.

Exceptions to standard warranty, effective within above limitations:

- Alkaline batteries are not covered under warranty.
- Maximum 90 days parts and labor warranty covers the following from date of installation: Glass windows due to defect, door seals, rubber seals, spark ignitors, and drip shields.

### EXCLUSIONS:

- Equipment failure relating to improper installation. Examples are: improper utility connection, improper utilities supply and problems due to ventilation.
- Equipment that has not been properly maintained. Examples are: calibration of controls, adjustments to pilots and burners, damage from improper cleaning, and water damage to controls.
- Equipment that has not been used in an appropriate manner, or has been subject to misuse or misapplication, neglect, abuse, accident, damage during transit or delivery, fire, flood, riot, or act of mother nature.

If the equipment has been changed, altered, modified, or repaired by other than a qualified service technician during or after the limited warranty period, then the manufacturer shall not be liable for any damages to any person or to any property which may result from the use of the equipment thereafter.

Equipment failure caused by inadequate water quality is not covered under warranty. WATER QUALITY must not exceed the following limits: Total Dissolved Solids (TDS) - 60 PPM (Parts Per Million), Hardness - 2 Grains or 35 PPM, PH Factor - 7.0 to 7.5. Water pressure 30 PSI minimum, 60 PSI maximum. Boiler maintenance is the responsibility of the owner and is not covered by warranty.

Southbend does not assume any liability for extended delays in replacing or repairing any items in the equipment beyond the control of Southbend. "Southbend shall not be liable for consequential or special damages of any nature that may arise in connection with such product or part." Should service be required at times that normally involve premium labor rates, the owner shall be charged for the difference between normal service rates and such premium rates.

This warranty only covers products shipped into the 48 contiguous United States, Alaska, and Hawaii.

This equipment is intended for commercial use only. Warranty is void if the equipment is installed in other than commercial application.



# Limited Warranty

Service Agencies will be limited to three months on labor, and materials (parts) effective from the date of installation. See LIMITED WARRANTY - REPLACEMENT PARTS for conditions and limitations.

“THE FOREGOING WARRANTY IS IN LIEU OF ANY AND ALL OTHER WARRANTIES EXPRESSED OR IMPLIED INCLUDING ANY IMPLIED WARRANTY OF MERCHANTABILITY OR FITNESS, AND CONSTITUTES THE ENTIRE LIABILITY OF SOUTHBEND. IN NO EVENT DOES THE LIMITED WARRANTY EXTEND BEYOND THE DURATION OF ONE YEAR FROM THE EFFECTIVE DATE OF SAID WARRANTY -EXCEPT WHERE NOTED.”

**WARRANTY:** Southbend's warranty of products is limited to one year from date of purchase on both parts and labor. However, the warranty term shall not exceed 18 months from the date of purchase from the factory and installation of the product. Warranty coverage is limited to the continental United States and Canada. Southbend reserves the right to service equipment and or provide replacements on a prorated basis throughout the warranty term as deemed appropriate by Southbend. Any equipment removed from the operators facility without the written approval of Southbend prior is done so at the responsibility of the party doing so. Southbend will not accept any return or continue any repair unless written authorization is given prior to removal. Any party removing equipment does so at their own expense and liability. This warranty is as designated in Southbend's published Limited Warranty.

## Warranty Disclaimer Statements

1. **NON-Quarry Tile Floor Policy** – “If installing on any NON-Quarry Tile floor (flooring other than quarry tile, cement or natural stone), contact the factory for installation options as damage due to improper installation is not covered under warranty.” – Applies to all Southbend equipment.
2. **Cleaning Warning** – “DO NOT use sheet pans when cleaning charbroilers. Use of sheet pans reflects too much heat into a non-flued area and causes irreparable damage, warping components. Damage due to blocking the charbroiler grates with a sheet pan while the burners are turned on is not covered under warranty.” – Applies to Southbend Ultimate and S Series Range, Platinum Range and HD Counterline.
3. **Mileage Limit for Factory Performance Checks** – Equipment that qualifies for a free factory performance check will include labor and mileage charges up to 100 miles round trip (or 50 miles each way) from the authorized service agency office. Locations further than 50 miles from the agency office may be charged an excess mileage fee to cover the mileage cost above the 100 miles round trip limit.
4. **Terry System Cartridge Changes / Installation** – “2-3 gallons of water MUST be purged at each cartridge change or new installation prior to water supply being fed to the steamer. Failure to do so can result in component damage within the steamer which is not covered under warranty. For additional guidance on proper installation, refer to install documentation provided with each Terry System and Replacement Cartridge Set.” – Applies to ALL Southbend Steam Steamers that require a water connection (i.e., auto-fill steamer models).



# Additional Warranty

## ADDITIONAL 1 YEAR WARRANTY NET PRICES

(Parts and Labor)

AN EXTENSION OF SOUTHBEND'S STANDARD WARRANTY MAY BE PURCHASED WITH NEW EQUIPMENT UP TO 60 DAYS AFTER THE ORIGINAL EQUIPMENT PURCHASE. EXTENDED WARRANTY DOES NOT AFFECT ITEMS WHICH HAVE LIMITATIONS OR EXTENDED PERIODS OF COVERAGE IN THE PUBLISHED SOUTHBEND LIMITED WARRANTY.

### Restaurant Ranges

Restaurant Ranges (Electric, Ultimate or S-Series) with any single oven or single cabinet base..\$680  
 Restaurant Ranges (Ultimate or S-Series) with any double oven or double cabinet base.....\$1,300

### Sectional

Sectional - Any Oven Base, Cabinet, Modular ..... \$816

### Convection Ovens

Platinum Series- per deck..... \$680  
 1/2 Size - per deck ..... \$680  
 TV-Series - per deck ..... \$680

### Broilers

Upright Broilers/Steakhouse Broiler ..... \$680  
 Compact Infra-red Broilers..... \$680  
 Radiant Salamanders/Broilers..... \$680  
 Cheesemelters ..... \$680

### Counterline

Heavy Duty Counterline ..... \$715

### Fryers & Pasta Cookers

All Fryers and Pasta Cookers..... \$715

*From the Southbend Team...  
 Thank you for your support!*



# Additional Warranty



## ADDITIONAL 1 YEAR WARRANTY NET PRICES

(Parts and Labor)

AN EXTENSION OF Southbend'S STANDARD WARRANTY MAY BE PURCHASED WITH NEW EQUIPMENT UP TO 60 DAYS AFTER THE ORIGINAL EQUIPMENT PURCHASE. EXTENDED WARRANTY DOES NOT AFFECT ITEMS WHICH HAVE LIMITATIONS OR EXTENDED PERIODS OF COVERAGE IN THE PUBLISHED Southbend LIMITED WARRANTY.



Counter Steamers .....	\$1,298
Braising Pans .....	\$1,376
Kettles .....	\$1,376
Boiler Base Steamers .....	\$1,376
Eco-Tech Plus® Series .....	\$2,457
Sirius II Series (per section) .....	\$1,694
Steam-It Countertop Pressure Cooker (per section).....	\$2,366
Universe Plus Floor Model Tilting Skillets.....	\$1,273



# Southbend MAP & M.R.I.C.P. Policy

## Minimum Advertised Price & Minimum Resale Internet Cart

### MINIMUM ADVERTISED PRICE (MAP) POLICY

This Policy applies to all means of Advertised Pricing for all Middleby Commercial Foodservice Brands

The Middleby Corporation (hereinafter "the Corporation") is committed to supporting our Authorized Dealers and resellers selling the Corporation's products in or into the United States & Canada by continuing to provide high-quality, premium products for the foodservice industry while maintaining its brand equity and integrity. This Minimum Advertised Price Policy ("MAP POLICY") applies to ANY and ALL means of Advertised Pricing, to ANY and ALL customers, for the Commercial Foodservice Brands within the Corporation, as defined in Exhibit A. Advertising at a price below MAP will be considered a violation of this Policy. This MAP Policy will apply to any activity which the Corporation determines, in its sole and absolute discretion, is designed or intended to circumvent the intent of this MAP Policy.

- MAP Policy pricing is the Current List Price less a discount defined by Individual Brand (see Exhibit A). At a minimum, MAP would be rounded down to the nearest whole number. Certain products within a Brand's portfolio have specific MAP pricing (see Exhibit A) for pricing.
- If a Dealer offers or combines (i.e. "bundling") one or more products from a single or multiple brands of the Corporation in an advertisement, the aggregate price for all of the Corporation's products offered for sale in combination may not be lower than the cumulative MAP for each of the products when sold separately.
- At the Dealer's sole expense, the Dealer may offer or combine the following items of casters, warranty, or freight into their product's sell price, not to be below the product's MAP pricing.

The MAP Policy applies to any advertisements of the Corporation's products and designs in any and all media, including but not limited to, print advertising (e.g. magazines, catalogs, newspapers, posters, flyers and direct mail), e-mail and facsimile advertising (e.g. broadcast campaigns, flyers, coupons and similar inserts), internet or similar electronic media (e.g. Amazon, eBay, Google), Dealer websites, internet banner ads, social networks, social media blasts, search engine advertising and all other types of digital signage.

All internet advertised prices must show the product's "MAP" price or higher. Any communications stating or implying that a price below MAP may be found elsewhere on the site, that is initiated by the Dealer, would constitute advertising and would be deemed a violation of this MAP Policy. Dealers may not make any statements, displays, or communications that indicate, state, imply, or suggest that a lower price may be found at the online check out, including but not limited to: "Call for Pricing", "Chat for Pricing", "Text for Pricing", "Click for Pricing", "Email for Pricing", "Add to Cart for Pricing", "Mouse Over for Pricing", "Log In for Pricing", strike-through the price, or any of the like. This includes "shopping cart price", "chat box price" and "emailed price" that appear on the internet in any format on any Dealer's public internet website or public internet-based account, including internet search engine shopping feeds, are all subject to the Corporation MAP Policy. Website features such as automated "bounce-back" pricing emails, pre-formatted email responses, forms, automatic price display, loyalty and reward point systems and other similar features are considered "advertising" under this MAP Policy. Under this MAP Policy, the Corporation prohibits the use of split-screen, side-by-side advertising, or pop-ups to advertise a similar product of any other brand other than those that are manufactured by other brands within the Corporation. The Corporation prohibits any Dealer from redirecting (automatically, inadvertently or otherwise) a customer who is in search of a product of the Corporation or item number to any other Non Middleby brand.

No Dealer may advertise a product of the Corporation at a price in violation of this MAP Policy on any third-party platform such as Amazon, eBay, Google or any like platforms in which it may operate as a vendor or have a re-distributor operate on its behalf. No Dealer may advertise a price in violation of this MAP Policy in an effort to match or beat a competitor's price. It is a violation of the MAP Policy to advertise a price below MAP pricing, even if such advertised price was automatically or manually generated due to a MAP Policy violation by a vendor or competitor on another medium or platform.

From time to time, the Corporation may discontinue certain products or engage in promotions with respect to certain products. In such events, the Corporation reserves the right to modify or suspend the MAP Policy with respect to the affected products at its sole discretion. Such changes shall apply equally to all Authorized Dealers of the Corporation.



## MINIMUM RESALE INTERNET CART PRICE (MRICP) POLICY

As Brand applicable, the Minimum Resale Internet Cart Price ("MRICP") applies to the final internet check out prices regardless of providing a customer "log in", membership, or similar (i.e., shopping cart prices, chat box prices, emailed prices, and prices on the internet website or search engines) of the Corporation's products. The Corporation requires that when Dealers sell select products (see Exhibit A) through internet sales that these products are subject to MRICP and are sold at a Brand defined discount (see Exhibit A) rounded down to the nearest whole number off the Current List Price. This MRICP Policy will apply to any activity which the Corporation determines, in its sole and absolute discretion, is designed or intended to circumvent the Intent of this MRICP Policy.

The MAP Policy and MRICP Policy apply only to advertised prices and do not apply to the price at which the products are actually sold or offered for sale to an individual customer at a Dealer's place of business, including contract negotiations, or negotiations in the field. The decision to implement and enforce the MAP Policy and MRICP Policy is solely to protect the Corporation's brands, reputation and competitiveness and the Authorized Dealers who promote and sell our products based on quantitative and qualitative factors.

### POLICY VIOLATIONS

These MAP and MRICP Policies are not Intended as, nor are they to be construed as, an attempt by the Corporation to set advertised or resale prices or an agreement between the Corporation and any Authorized Dealer or other party. In addition, the Corporation will not accept any assurances of compliance with these MAP or MRICP Policies from any Authorized Dealer. Each Authorized dealer must independently choose whether to comply with the terms of these MAP and MRICP Policies. These MAP and MRICP Policies are not negotiable and will not be altered for any individual Authorized Dealer.

The Corporation, or its agent(s), will conduct a reasonable investigation in response to a suspected MAP and MRICP Policy violation. Failure to cooperate by any Authorized Dealer, including retaliatory actions by any Authorized Dealer with the Corporation's investigation will be considered an additional violation.

Failure to meet the terms and conditions of the MAP and MRICP Policies will result in full, unconditional enforcement of the penalties described below. The event of a violation will be determined solely by the Corporation.

Dealer will be subject to penalties (over a 12-month period) up to and including but not limited to:

- 1st violation: The Corporation at a minimum will issue an email communication to the non-compliant dealer requesting their compliance to the MAP and MRICP Policies. Failure to comply within 48 hours (2 days) or a repeated offense within a 30 day period will be considered a 2nd violation.
- 2nd violation: The Corporation at a minimum will issue an email notification to the non-compliant dealer, from the corporation or by the individual brand, requesting their compliance to the MAP and MRICP Policies and will hold all shipments from that Brand and or the Corporation, until all violations are resolved. Failure to comply within 48 hours (2 days) or a repeated offense within a 6 month period will be considered a 3rd violation.
- 3rd violation and each violation thereafter: The Corporation, or the brand, at a minimum will issue an email notification to the non-compliant dealer and applicable buying group as applicable requiring their compliance to the MAP and MRICP Policies and will result in (a) dealer's net pricing being increased to standard Brand market discount (see Exhibit A) off ALL Middleby Corporation Brands published List Price and (b) any and ALL available rebates, marketing incentives, or program dollars (accrued or due in total) will be forfeited. Failure to comply within 48 hours (2 days) or a repeated offense within a 12-month period, The Corporation at a minimum will issue an email notification to the non-compliant dealer and applicable buying group as applicable informing them of the a) indefinite suspension of their account with Middleby Corporation and b) permission to use the Corporation's brand trademarks, trade names, corporate logos, product images and product content will be indefinitely revoked. Reinstatement of the account, preferred pricing and applicable incentives or rebates may be re-evaluated by the Corporation in its sole discretion after 30 days.

### DEALER ACCOUNTABILITY

In the case of a MAP or MRICP violation by a reseller who does not have an authorized relationship with the Corporation's brands and instead purchases the Corporation's products from an Authorized Dealer or any other reseller (i.e., dealer-to-dealer re-sale), the Corporation will pursue enforcement actions against the Authorized Dealer as provided above in these Policies.

### OTHER PROVISIONS

These Policies are managed by the MAP/MRICP Policy Administrator for the Corporation. Only the MAP/MRICP Policy Administrator, Brand President, or Brand Vice President of Sales may provide direction to Dealers concerning compliance with the MAP and MRICP Policies. And ONLY the Brand President, Brand Vice President of Sales may authorize exceptions to the Policies. No other individuals, including any employee or representative of the Brands, may provide such direction or authorizations regarding these Policies to any Dealer. It is the Dealer's sole responsibility to remain aware of any changes to the Corporation's MAP and MRICP Policies.

The terms of the MAP and MRICP Policies are confidential and are not to be disclosed to other parties. The Corporation has adopted the MAP and MRICP Policies unilaterally in furtherance of its independent business strategy and reserves, at its sole discretion, the right to change the Policies and to interpret, enforce and otherwise handle all questions and issues related to the Policies.





1100 Old Honeycutt Road • Fuquay-Varina, NC 27526  
Phone:(919)-762-1000  
[www.southbendnc.com](http://www.southbendnc.com)