

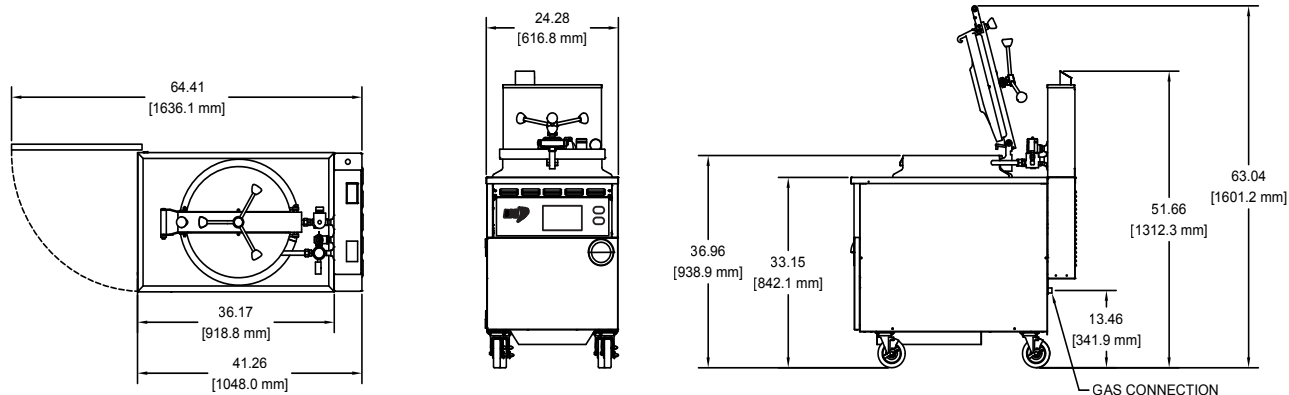

X-LARGE VOLUME DEEP FRYER – PRESSURE VAT – FILTER SYSTEM – GAS OPERATION
TOUCHSCREEN CONTROLS – TRAINING CENTRAL

Model: FKG-TC

EQUIPMENT DIMENSIONS



MECHANICAL SPECIFICATIONS

Dimension	Uncrated
Height	51 3/4" (1312.3 mm)
Width	24 5/16" (616.8 mm)
Depth	41 5/16" (1048.0 mm)
Floor Space	7.0 sq. ft. (.65 sq m)
Weight	440 lb (199.6 kg)

ELECTRICAL OPTIONS

Volts	Amps	kW	Wires + Grnd	Phase
120/60Hz	5.6	.6	2	1

GAS OPTIONS

	BTU/hr	Inlet Pressure
Natural Gas	66,000	MIN. 4" W.C. / MAX. 14" W.C.
LP Gas	70,000	MIN. 4" W.C. / MAX. 14" W.C.

CLEARANCES

Front	Sides	Rear
24"	0"	6"

GAS CONNECTION

3/4" NPT

PARAMETER

VALUE

Operating PSI	12 psi
Safety Release PSI	15 psi

INCLUDED ACCESSORIES

- One white pot-scrubber brush
- One white drain brush
- One L-tipped brush
- One long black brush
- One short black brush
- One bail-handle basket
- One pair 13" insulated mitts
- Package of five filter papers



bkideas.com

© BKI LI0283C/08-06
Specifications are subject to
change without notice.

BKI Worldwide, Inc.
42 Allen Martin Drive
Essex Junction, VT 05452
(802) 658-6600

Visit bkideas.com to view all accessories for
this model.

10.7.2019



*Extra-Large Gas
Pressure Fryer With Touchscreen
Controls and Training Central™*

MODEL: FKG-TC





PRESSURE-COOKING

Pressure-cooking results in moist and tender meat and longer holding life.



GAS OPERATION

Natural/LP gas is powerful and efficient with incredible recuperation times.



TOUCHSCREEN CONTROLS

Intuitive touchscreen controls feature the Training Central™.

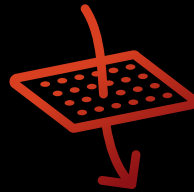

BUILT-IN FILTRATION

Filtration ensures consistent-tasting food and longer oil life.

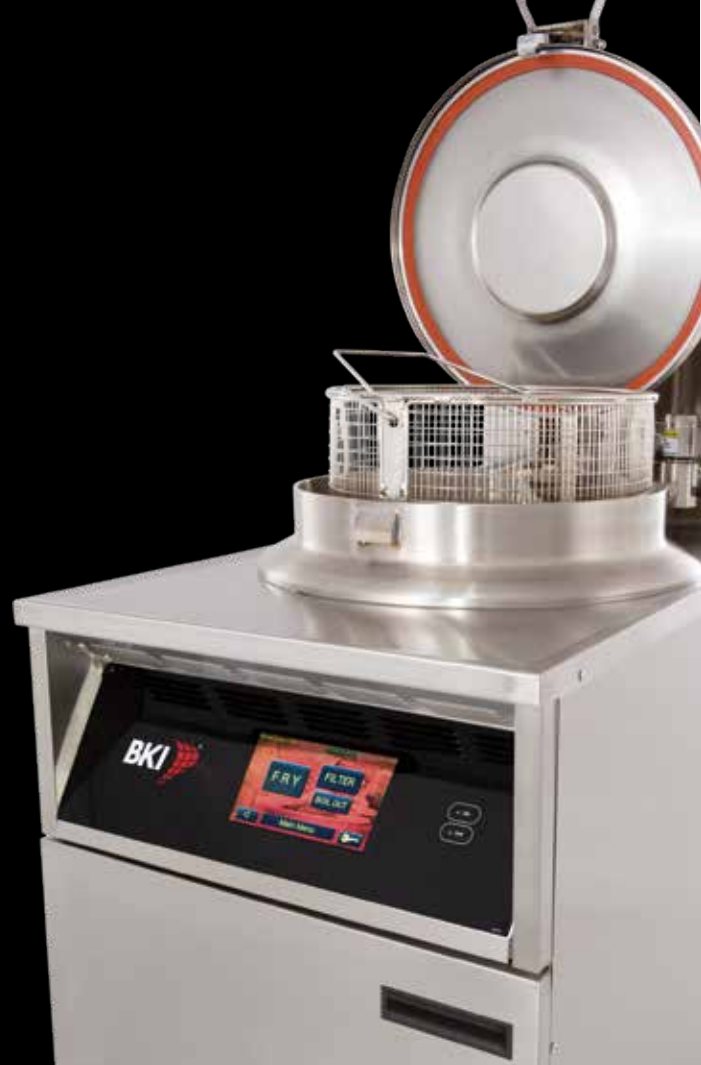

Built-In Training



FEATURES AT A GLANCE

- 7" LCD touchscreen controls with Training Central™
- USB for uploading recipes
- Heavy-duty aluminum oil vat lid with rolled edges
- Gas operation
- Up to 70,000 BTUH
- 24 lb (10.8 kg) product with optional grande basket with 75 lb (34 kg) oil capacity
- Utilizes controlled low pressure
- Pressure-regulated lid interlock system
- 5" casters for easy mobility
- Stainless steel construction
- Built-in filtration system
- Assembled in USA

This extra-large, gas pressure fryer is designed for simple operation, long life, and high product volume. The results from pressure-frying are delicious! As pressure builds up in the vat, moisture in the protein is trapped, resulting in perfectly tender and moist meat that retains a crispy exterior. Pressure-fried foods have a longer holding life, too—great for grocery deli grab-n-go displays. Combine this fryer with a hot case, and your food will be hot and crispy for hours!

The new touchscreen controls are easy to use and feature the BKI® Training Central™, the first of its kind in the industry. In minutes, new employees will be managing virtually every operation—programming, cooking, cleaning, filtering, boiling out, and more—simply by following intuitive, step-by-step screen instructions that provide instant feedback. Training Central reduces time spent on employee training and retraining to save you money.

The heat exchangers and igniter box are completely submerged in oil inside the vat to maximize efficiency and speed recovery times. A cold zone in the vat collects breading fall-off to keep oil fresh, while the built-in filtration system extends oil life to save you money and produce consistent results. The patented quick-disconnect allows for easy removal of the vat, so filtering oil is easy and safe.

Want the ultimate performance out of your kitchen? Talk to us about the FKG-TC series gas fryers.

Save time and money with the BKI® Training Central™.

Training and retraining employees on equipment operation takes up precious time you simply don't have. Our Training Central is built-into our touchscreen controls, so new employees can quickly look up any procedure and follow the easy, step-by-step prompts. The benefits are clear: train less, fry more!

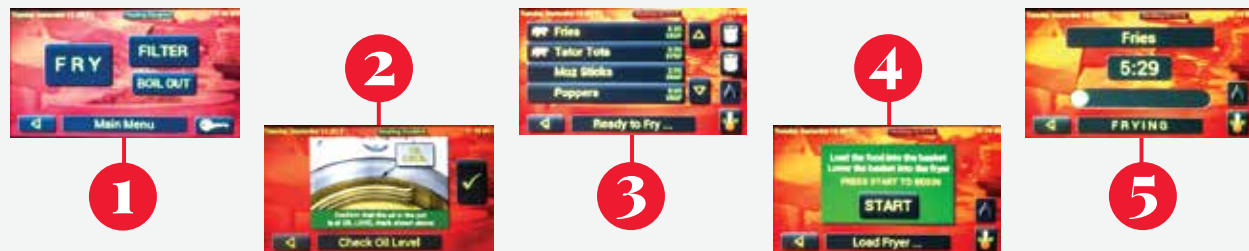

Call or visit our website to learn more about our innovative cooking equipment.

802.658.6600 | www.bkideas.com