



POWERFULLY COLD.
PERFECTLY HIDDEN.

VIKING[®]
SIMPLY **ICONIC**



VIKING®

VEIL™

INTEGRATED REFRIGERATION

Vision. To anticipate what lies just beyond sight.

For more than 40 years, Viking has embodied that foresight. As the pioneer of the professional-grade residential range, our innovations have defined the global standard for the modern luxury kitchen.

Now, Viking redefines that standard once again with VEIL™ Integrated Refrigeration, a seamless fusion of design, performance, and innovation. This is not simply cold storage, but a sophisticated food preservation system that showcases refrigeration as design presentation.

Adaptable to any lifestyle, customizable to any vision, VEIL™ Integrated Refrigeration becomes an integral expression of the kitchen itself.

VIKING®
SIMPLY ICONIC



INTRODUCING ALL-NEW INTEGRATED REFRIGERATION

AVAILABLE IN 36/30/24" WIDE

INTEGRATION THANKS TO INNOVATION

The **Patented Double Pivot Hinge** is a breakthrough in design flexibility. This engineering marvel allows units to be installed with as little as a **1/8" reveal** for a true built-in, furniture-like aesthetic. Doors open inward, allowing for hinge-to-hinge installation and maximum accessibility without compromising the clean, streamlined look professionals, designers, and homeowners demand.

SUPERIOR FOOD PRESERVATION

Lateral Cooling Technology ensures uniform air circulation and consistent temperatures across every compartment, preserving freshness and reducing spoilage. From leafy greens to fine cuts of meat, everything stored receives equal care.

FILTER-FREE FRESHNESS

Exclusive to Viking Integrated Refrigerators, the **PlasmaCluster™ Ion Air Purifier** utilizes advanced ion technology to eliminate airborne bacteria, mold, and odors to enhance food preservation—keeping food fresher, longer. Available on Bottom Freezer and All Refrigerators.

BEAUTY AND CONVENIENCE

Full Color Smart Touch TFT Display simplifies navigating through settings and features with clear visuals and intuitive controls. **Stainless Steel Back Wall** provides beauty and robustness and reflects the top and side mounted **LED Lighting** which reduce energy consumption while enhancing visibility. Repositionable shelves and door bins adapt easily to your storage needs, without ever leaving the rails.

PERFORMANCE FEATURES

The **Low Temperature Zone** operates at a temperature that is 2°F to 3°F lower than the rest of the refrigerator, providing the perfect location for meats and other foods that need lower temperature. The **Antibacterial Stainless Steel Drawers** in this zone are bead-blasted to resist bacteria and germs. Bottom Freezer boasts **Triple Mode Convertible Drawers** that can be converted to Refrigerator, Extend Fresh, or Freezer modes with a simple touch on the Smart Color Display.



36"W. BOTTOM FREEZER
FDBMIC7360 (R/L)



36"W. ALL REFRIGERATOR
FDREIC7360 (R/L)



30"W. ALL REFRIGERATOR
FDREIC7300 (R/L)



24"W. ALL REFRIGERATOR
FDREIC7240 (R/L)



INTRODUCING
**ALL-NEW INTEGRATED
 FREEZER COLUMNS**

AVAILABLE IN 36/30/24/18" WIDE

INTEGRATION THANKS TO INNOVATION

The **Patented Double Pivot Hinge** is a breakthrough in design flexibility. This engineering marvel allows units to be installed with as little as a **1/8" reveal** for a true built-in, furniture-like aesthetic. Doors open inward, allowing for hinge-to-hinge installation and maximum accessibility without compromising the clean, streamlined look professionals, designers, and homeowners demand.

SUPERIOR FOOD PRESERVATION

Lateral Cooling Technology ensures uniform air circulation and consistent temperatures across every compartment, preserving freshness and reducing spoilage. From leafy greens to fine cuts of meat, everything stored receives equal care.

NO HEATER KIT NEEDED

Units have side vents so there is no need for a blanket or heater kit between units to prevent condensation as the warm air from the unit compartment will achieve this task.

BEAUTY AND CONVENIENCE

Full Color Smart Touch TFT Display simplifies navigating through settings and features with clear visuals and intuitive controls. **Stainless Steel Back Wall** provides beauty and robustness and reflects the top and side mounted **LED Lighting** which reduce energy consumption while enhancing visibility. Repositionable shelves and door bins adapt easily to your storage needs, without ever leaving the rails.

BEVERAGE BONANZA

Thoughtful luxuries abound. The **Bottle Chiller** rapidly cools favorite beverages with a built-in timer alarm. A **Dual-Size Ice Maker** offers both medium and large cubes at the touch of a button, while the MaxIce feature delivers an extra 1.1 pounds of ice daily—perfect for effortless entertaining.



**36"W. ALL FREEZER
 FDFZIC7360 (R/L)**



**30"W. ALL FREEZER
 FDFZIC7300 (R/L)**



**24"W. ALL FREEZER
 FDFZIC7240 (R/L)**



**18"W. ALL FREEZER
 FDFZIC7180 (R/L)**

INTRODUCING ALL-NEW INTEGRATED WINE CELLARS

AVAILABLE IN 30/24" WIDE

INTEGRATION THANKS TO INNOVATION

The **Patented Double Pivot Hinge** is a breakthrough in design flexibility. This engineering marvel allows units to be installed with as little as a **1/8" reveal** for a true built-in, furniture-like aesthetic. Doors open inward, allowing for hinge-to-hinge installation and maximum accessibility without compromising the clean, streamlined look professionals, designers, and homeowners demand.

PRESERVATION WITH PRESTIGE

Preserve **108 bottles** of wine (or **72 bottles** in the 24" wide model) in this **Dual Zone Wine Column** complete with temperature adjustments from 39°F (4°C) to 64°F (18°C), a **Triple-Pane, Bronzed Glass Door** to protect from Harmful UV rays and humidity controls of High/Medium/Low. Two active carbon filters ensure the compartment is free of odors that could enter the wine.

BEAUTY AND CONVENIENCE

Full Color Smart Touch TFT Display simplifies navigating through settings and features with clear visuals and intuitive controls. **Stainless Steel Back Wall** provides beauty and robustness and reflects the top and side mounted **LED Lighting** which reduce energy consumption while enhancing visibility. 12 natural beech wood racks with soft-closing feature cradles the wine to minimize vibration.



30"W. WINE CELLAR
FDWCIC7300 (R/L)



24"W. WINE CELLAR
FDWCIC7240 (R/L)

ULTIMATE FEATURES FOR ADVANCED PERFORMANCE



Plasmacluster

EXCLUSIVE! FILTER-FREE FRESHNESS

With exclusive technology only available in Viking Integrated Refrigerators, the **PlasmaCluster™ Ion Air Purifier** utilizes advanced ion technology to eliminate airborne bacteria, mold, and odors to enhance food preservation—keeping food fresher, longer. Available on Bottom Freezer and All Refrigerators.



INNOVATIVE INTEGRATION

The **Patented Double Pivot Hinge** allows units to be installed with as little as a **1/8" reveal**. Doors open inward, allowing for hinge-to-hinge installation and maximum accessibility.



CLEARLY INTUITIVE

Full Color Smart Touch TFT Display simplifies navigating through settings and features with clear visuals and intuitive controls.



SUPERIOR FOOD PRESERVATION

Lateral Cooling Technology ensures uniform air circulation and consistent temperatures across every compartment, preserving freshness and reducing spoilage.



EASY-TO-USE STORAGE

Repositionable shelves and **door bins** adapt easily to your storage needs, without ever leaving the rails.



PERFORMANCE FEATURES

The **Antibacterial Stainless Steel Drawers** in this zone are bead-blasted to resist bacteria and germs.



BEAUTY AND CONVENIENCE

Stainless Steel Back Wall reflects top and side mounted **LED Lighting** which reduce energy consumption while enhancing visibility.

MAKE IT YOUR OWN

INTEGRATED PANEL OPTIONS



CUSTOM PANEL



PROFESSIONAL
DOOR + HANDLE KIT



RVL BLACK GLASS
DOOR + HANDLE KIT

*Black Glass not available
on Wine Columns



RVL STAINLESS STEEL
DOOR + HANDLE KIT

FLEX YOUR STYLE WITH DESIGNER-CURATED COLORS

While iconic stainless steel endures as a hallmark of timeless design, our new palette of 18 meticulously curated hues embodies both understated elegance and unapologetic individuality. Choose the Professional panel option to craft a kitchen as distinctive as your signature dish.



WE STAND BEHIND OUR PRODUCTS

- Two Year Full Warranty (*Parts and Labor*)
- Six Year Full Warranty on Refrigeration Sealed System (*Parts and Labor*)
- Twelve Year Limited Warranty on Refrigeration Sealed System. (*Parts Only*)

CUTOUT DIMENSIONS

Minimum cutout height:
84" (21.3 cm)

Cutout width:
36" model: 36" (91.4 cm)
30" model: 30" (76.2 cm)
24" model: 24" (61.0 cm)
18" model: 18" (45.7 cm)

Cutout widths for multiple products:

		A			
		18"	24"	30"	36"
B	18"	36" (914 mm)	42" (1067 mm)	48" (1220 mm)	54" (1372 mm)
	24"	42" (1067 mm)	48" (1220 mm)	54" (1372 mm)	60" (1524 mm)
	30"	48" (1220 mm)	54" (1372 mm)	60" (1524 mm)	66" (1676 mm)
	36"	54" (1372 mm)	60" (1524 mm)	66" (1676 mm)	72" (1829 mm)

Example: if appliance A is 24" and appliance B is 36" the required opening width will be 24" + 36" = 60"

Minimum cutout depth:
24" (61.0 cm) + panel thickness for flush installation

Area to be left clear for the anti-tipping brackets:
5" (12.7 cm) for both right and left sides

Appliance height:
83 1/2" (212.0 cm) + 1" (2.5 cm)

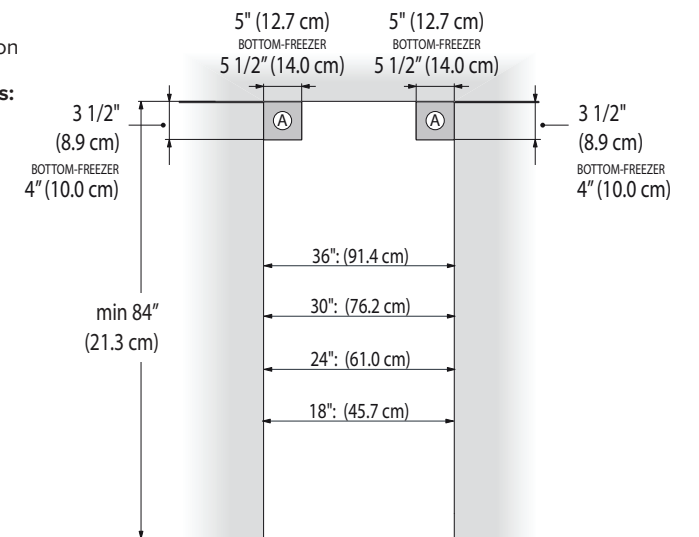

CLEARANCE DIMENSIONS

Door Swing Clearance

36" model: 58 5/8" (148.9 cm)
30" model: 52 5/8" (133.8 cm)
24" model: 46 3/4" (118.7 cm)
18" model: 40 3/4" (103.6 cm)

Minimum distance from the wall (hinge side)

36" model: 6 1/4" (15.9 cm)
30" model: 5 1/4" (13.2 cm)
24" model: 4 1/4" (10.8 cm)
18" model: 3 1/4" (8.2 cm)

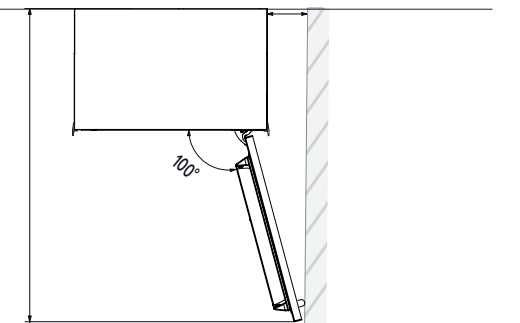

CUSTOM PANEL DIMENSIONS

Bottom-Freezer

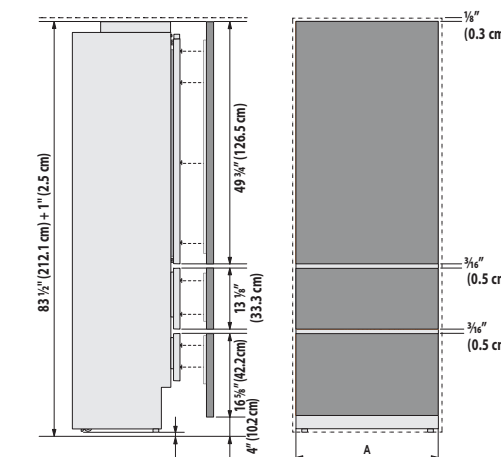

SIZE	A
36"	35 3/4"

Columns

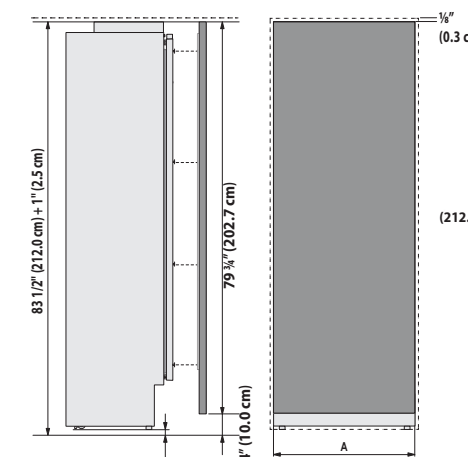

SIZE	A
18"	17 3/4"
24"	23 3/4"
30"	29 3/4"
36"	35 3/4"

Wine Column

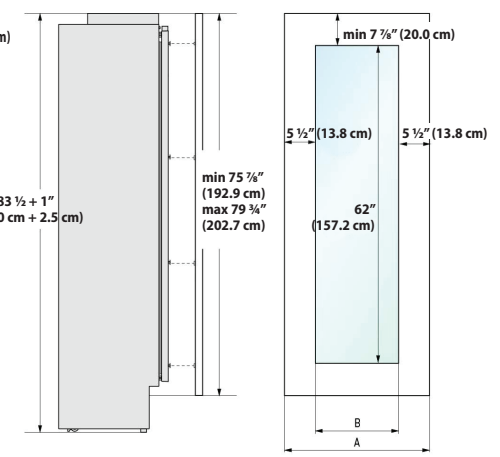

SIZE	A	B
24"	23 3/4"	12 7/8"

VIKING[®]
SIMPLY **ICONIC**

PART OF THE COMPOSITION BRANDS LUXURY PORTFOLIO

FIND YOUR LOCAL DEALER AT **VIKINGRANGE.COM**
FOR PRODUCT INFORMATION, CALL **1-888-845-4641** OR VISIT OUR WEBSITE

VIKING RANGE, LLC 111 FRONT STREET GREENWOOD, MS 38930 USA
© 2025 VIKING RANGE, LLC. ALL RIGHTS RESERVED.