



PERFECT FRY VENTLESS COUNTERTOP DEEP FRYERS REPLACEMENT PARTS LIST

MODELS

PFA 500	DSA 500
PFC 500	DSE 500
PFA 730	DSA 730
PFC 730	DSE 730

SERIAL NUMBER ALPHA TAG

DSA..... "PS"
DSE..... "PT"
PFA..... "PP"
PFC..... "PR"

EFFECTIVE MARCH 23, 2026

Superseding All Previous Parts Lists.

The Company reserves the right to make substitution in the event that items specified are not available.

ERRORS: Descriptive and/or typographic errors are subject to correction.

PERFECT FRY COMPANY

42 Allen Martin Drive, Essex Junction, Vermont 05452 USA Telephone: (802) 658-6600 Fax: (802) 860-3732
www.perfectfry.com

P/N 84219 Rev S (3/26)

WARNING

DO NOT store or use gasoline or other flammable vapors and liquids in the vicinity of this or any other appliance.

WARNING

Improper installation, alteration, service or maintenance can cause property damage, injury or death. Read the installation, operating and maintenance instructions thoroughly before installing or servicing this appliance.

WARNING

Installation, maintenance and repairs should be performed by a Perfect Fry Authorized Service and Parts (ASAP) company technician or other qualified personnel. Installation, maintenance or repairs by an unauthorized and unqualified personnel will void the warranty.

WARNING

Installation and all connections must be made according to national and local regulations and codes in force.

WARNING

A country approved all pole circuit breaker with a minimum open contact gap of 3mm must be used for proper installation. (CE countries)

WARNING

During the warranty period if a customer elects to use a non-original part or modifies an original part purchased from Perfect Fry and/or its Authorized Service and Parts (ASAP) companies, this warranty will be void. In addition, Perfect Fry and its affiliates will not be liable for any claims, damages or expenses incurred by the customer which arises directly or indirectly, in whole or in part, due to the installation of any modified part and/or received from an unauthorized service center.

WARNING

This appliance, when installed, must be electrically grounded in accordance with local codes, or in the absence of local codes, with the National Electrical Code, ANSI/NFPA 70, or the Canadian Electrical Code, CSA C22.2, as applicable.

WARNING

Adequate means must be provided to LIMIT the movement of this appliance without depending on the electrical cord connection. Single appliances equipped with legs must be stabilized by installing anchor straps. All appliances equipped with casters must be stabilized by installing restraining chains.

WARNING

This appliance is intended for professional use only and should be operated by fully trained and qualified personnel.

WARNING

If the supplied power cord is damaged, it must be replaced by a Perfect Fry Authorized Service and Parts (ASAP) company technician, or a similarly qualified person in order to avoid a hazard.

WARNING

The power supply must be disconnected before servicing, maintaining or cleaning this appliance.

WARNING

The appliance is NOT jet stream approved. DO NOT clean the appliance with a water jet.

WARNING

DO NOT attempt to move this appliance or transfer hot liquids from one container to another when the unit is at operating temperature or filled with hot liquids. Serious personal injury could result if skin comes in contact with the hot surfaces or liquids.

WARNING

DO NOT sit or stand on this appliance. Serious injury could result from slipping, falling or contact with hot surfaces or liquids.

WARNING

NEVER use the appliance as a step for cleaning or accessing the ventilation hood. Serious injury could result from slips, trips or from contacting hot surfaces or liquids.

WARNING

DO NOT use the appliance unless it is properly secured to a table, stand or freezer / refrigerated base suited to handle the weight of the entire appliance.

WARNING

DO NOT operate appliance unless all panels and access covers are attached correctly.

WARNING

It is recommended that this appliance be inspected by a qualified service technician for proper performance and operation on a yearly basis.

TABLE OF CONTENTS

PFA MODEL..... 4

PFC MODEL..... 6

PERFECT FRY FILTER AREA..... 8

PFA DOOR/DRAWER AREA..... 10

PFC DOOR..... 11

PERFECT FRY ELEMENT LIFT 12

PFA/PFC 3 PHASE 13

PFA ELECTRICAL CAVITY 14

PFC ELECTRICAL CAVITY 16

FIRE SYSTEM..... 18

OPTIONAL PERFECT FILTER 21

IMPORTANT FOR FUTURE REFERENCE

Please complete this information and retain this manual for the life of the equipment:

Model # _____

Serial # _____

Date Purchased _____

MODELS

PFA 500	DSA 500
PFC 500	DSE 500
PFA 730	DSA 730
PFC 730	DSE 730

SERIAL NUMBER ALPH TAG

DSA..... "PS"
 DSE..... "PT"
 PFA..... "PP"
 PFC..... "PR"

PFA MODEL

FIG. A

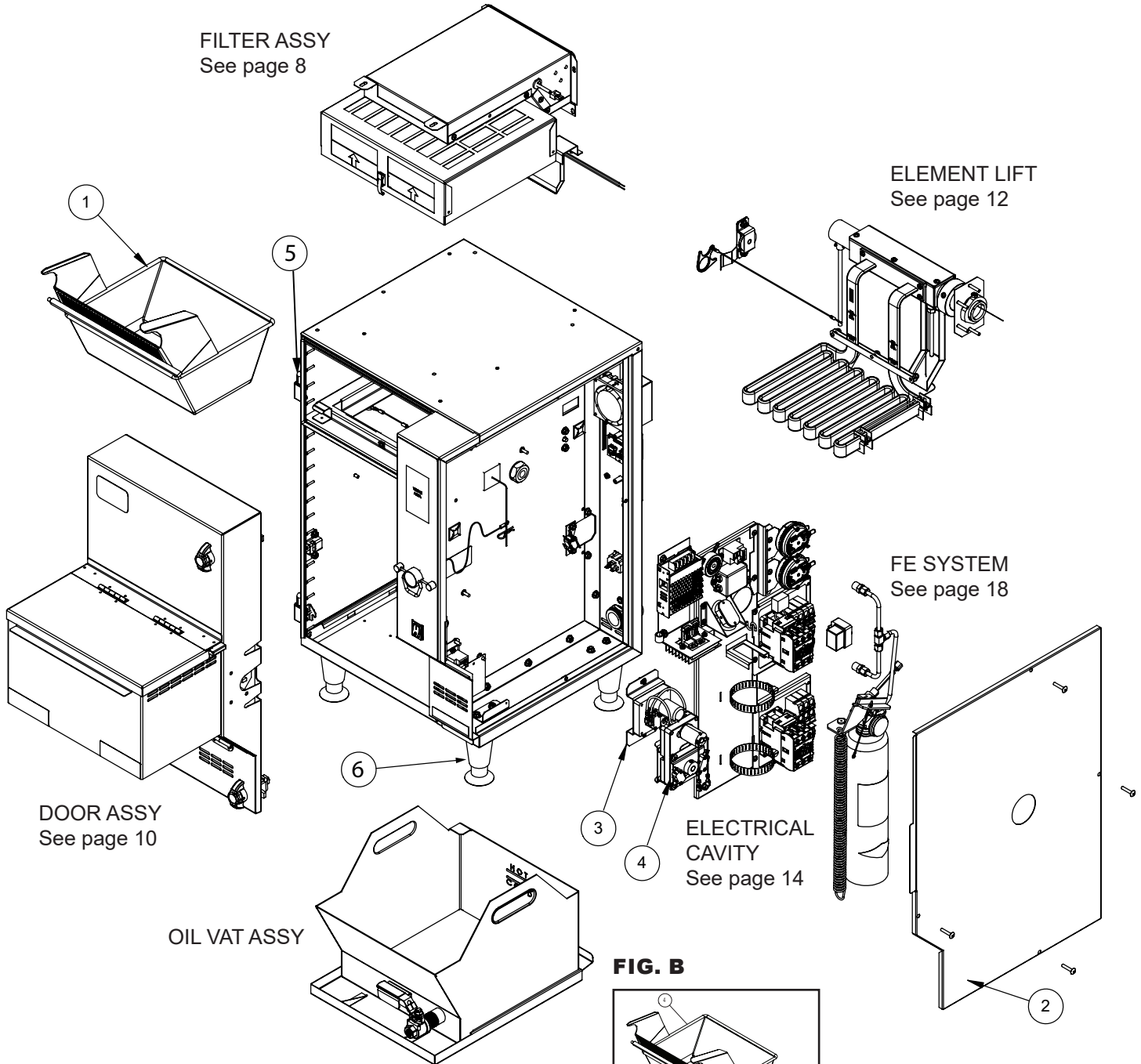

PFA MODEL

FIG. A

Item	P/N	Description	QTY
1	83258	ASSEMBLY, BASKET PFA	1
NS	83423	KIT, CONTROL FAN	1
2	83971	CABINET, COVER SIDE ASSEMBLY PFA	1
3	84042	DRAWER MOTOR ASSEMBLY	1
4	84406	KIT PFA 2.0 BASKET MOTOR	1
NS	84046	KIT, FIRE ALARM WITH INSTRUCTIONS	1
NS	83425	KIT, FLAT MAGNETIC SWITCH	-
NS	83424	KIT, ROUND MAGNETIC SWITCH	-
NS	83216	MOLDED SILICONE DOOR GASKET	-
5	83271	HINGE, LIFT OFF	-
NS	83272	GASKET, MOTOR PFA	-
NS	83447	CORD, HL, FRONT	-
6	83279	LEG, 4", PFA, FLANGED	-
NS	83554	ROCKER SWITCH, HEAT LAMP	-
NS	S0713	SILICONE 3OZ RTV	-
NS	83702	MINI MOLEX PIN REMOVAL TOOL	-
NS	84006	ASM, DRAWER & LID, PF	-
NS	84039	PANEL ASM, PFA	-

FIG. B

Item	P/N	Description	QTY
1	84118	TRAY, SPILL PFA	1
2	84040	ASSEMBLY, VAT OIL 11 LITER	1
2	84357	ASSEMBLY, VAT OIL 11 LITER WITH QUICK DISCONNECT	1
3	84215	VALVE, OIL MANUAL BALL SS	1
NS	84072	HOSE, OIL DRAINAGE	OPTION
NS	83625	HOSE, OIL DRAINAGE WITH QUICK DISCONNECT	OPTION
4	83258	BASKET ASSEMBLY, PFA	1

***DSA MODELS/PARTS IDENTICAL TO PFA WITH EXCLUSION OF FIRE SUPPRESSION SYSTEM.**

PFC MODEL

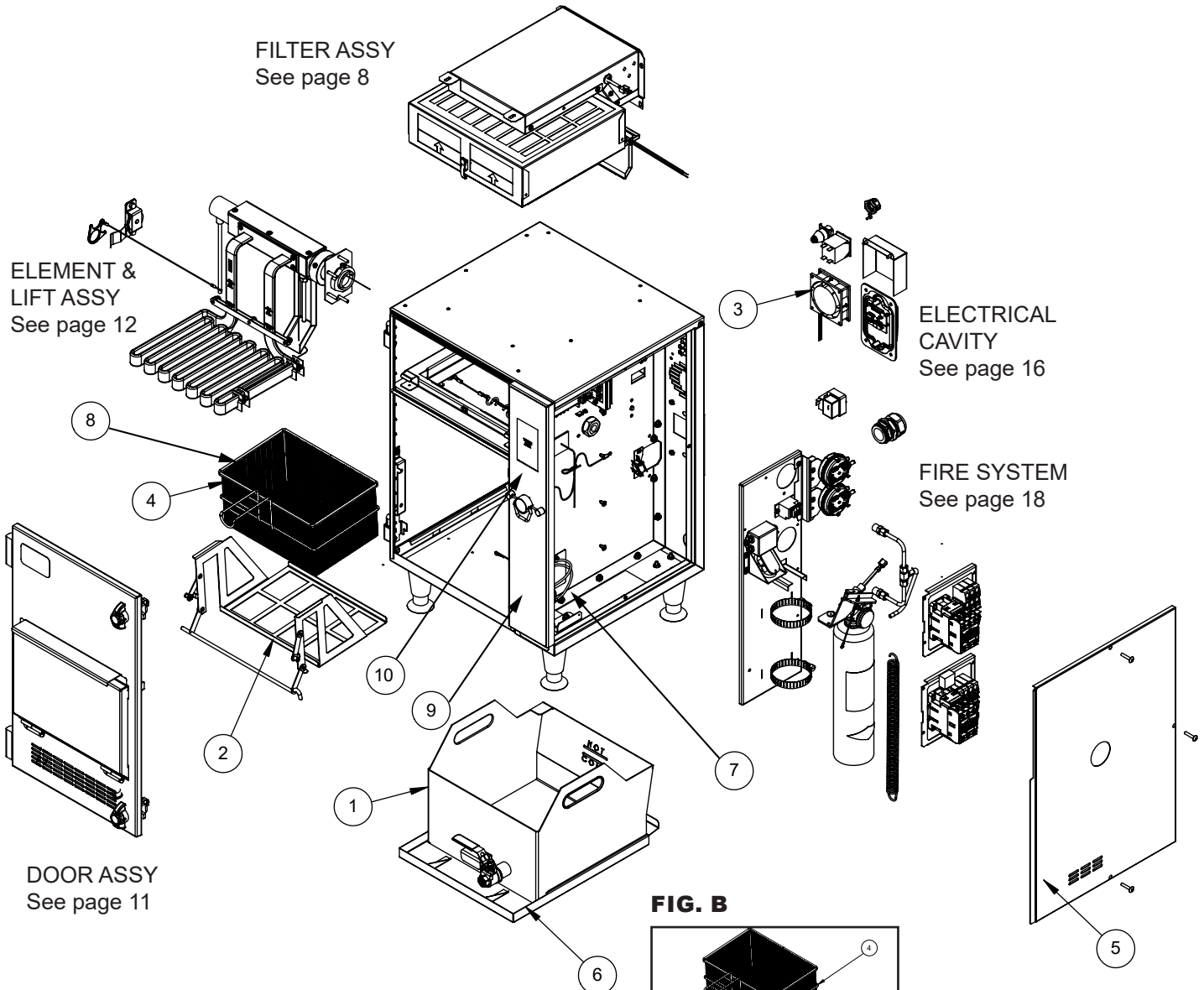
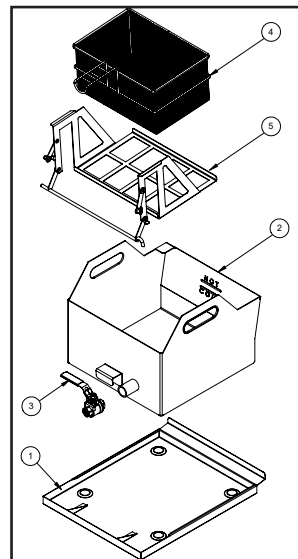

FIG. B



PFC MODEL

Item	P/N	Description	QTY
1	84143	ASSEMBLY, VAT PFC	1
2	84126	ASSEMBLY, BASKET LIFT PFC	1
3	83423	KIT, CONTROL FAN	1
4	83281	BASKET, EXTRA LARGE PFC	1
5	83858	CABINET, COVER SIDE ASSEMBLY PFC	1
6	84118	TRAY, SPILL PFC	1
7	84180	MOTOR ASSEMBLY	-
8	83649	KIT, COVER X-L BASKET	1
NS	83216	MOLDED SILICONE DOOR GASKET	-
NS	83625	FILTER DRAIN HOSE ASSEMBLY	-
NS	S0713	SILICONE 3OZ RTV	-
NS	83702	MINI MOLEX PIN REMOVAL TOOL	-
9	83425	KIT, FLAT MAGNETIC SWITCH	-
10	83424	KIT, ROUND MAGNETIC SWITCH	-

FIG. B

Item	P/N	Description	PFC QTY
1	84118	TRAY, SPILL PFC	1
2	84143	ASSEMBLY, VAT OIL PFC	1
3	84215	VALVE T, OIL MANUAL BALL SS.	-
NS	84072	HOSE, OIL DRAINAGE	1
4	83218	PFC BASKET	1
5	84126	PFC BASKET LIFT	1

***DSE MODELS/PARTS IDENTICAL TO PFC WITH EXCLUSION OF FIRE SUPPRESSION SYSTEM.**

PERFECT FRY FILTER AREA

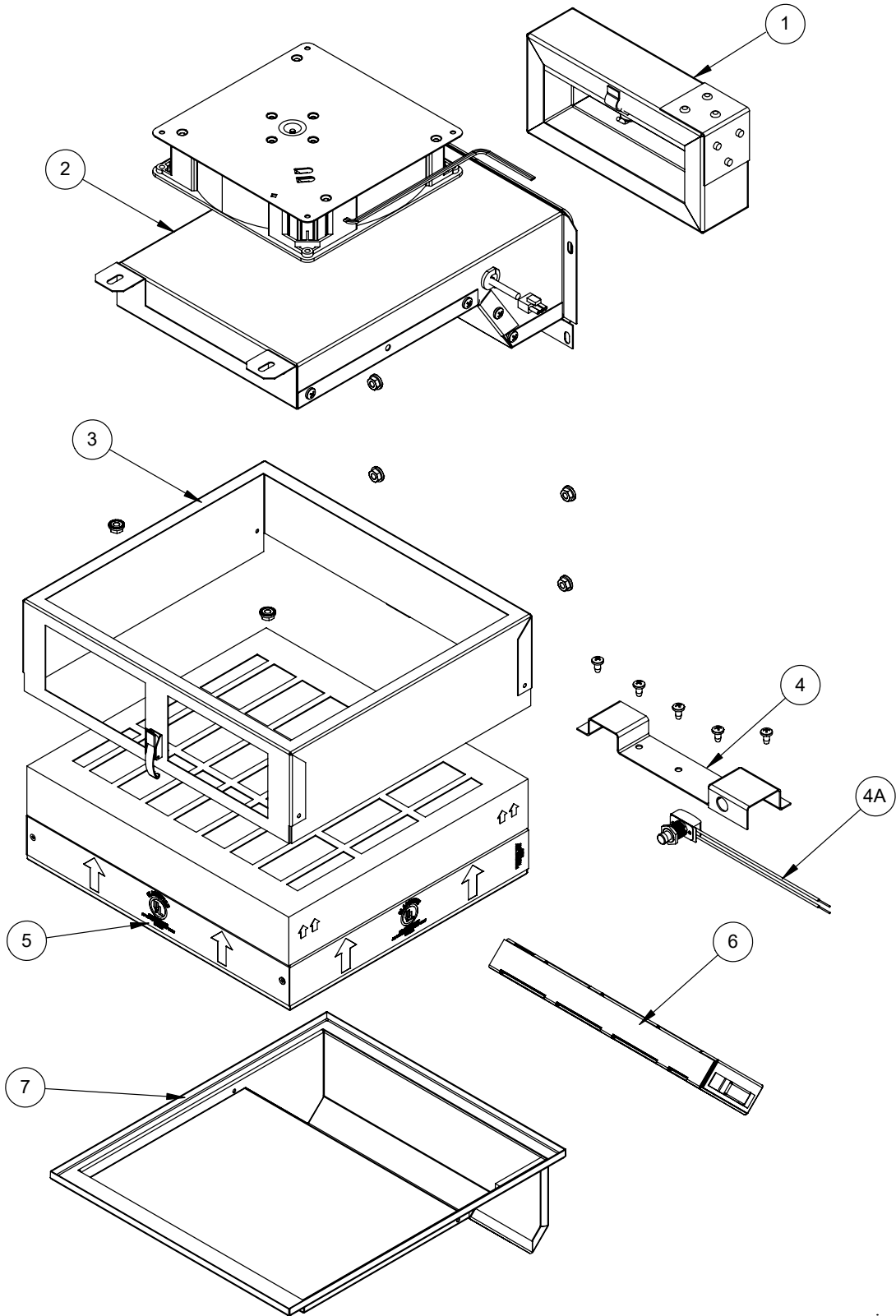

PERFECT FRY FILTER AREA

Item	P/N	Description	QTY
1	83252	DAMPER, FIRE ACTUATED	1
2	84149	ASSEMBLY, AIRFLOW MODULE	1
3	83909	BRACKET, FILTER CAGE	1
4	83908	BRACKET, AIR FILTER SWITCH	1
4A	84347	SWITCH, AIR FILTER	1
5	83902	2 STAGE FILTER	1
5a	84291	KIT, CARBON AIR FILTER	1
5b	83544	KIT, CARBON AIR FILTER, INTL	1
5c	83029	FILTER, ODOR HALF SIZE	1
5d	83036	PASSIVE FILTER, PF	1
5e	83543	KIT, AIR FILTERS, SERVICE	1
6	83251	ASSEMBLY, GREASE FILTER	1
7	84000	TRAY, GREASE FILTER	1
NS	83210	1/8" ID PVC TUBING	-

PFA DOOR/DRAWER AREA

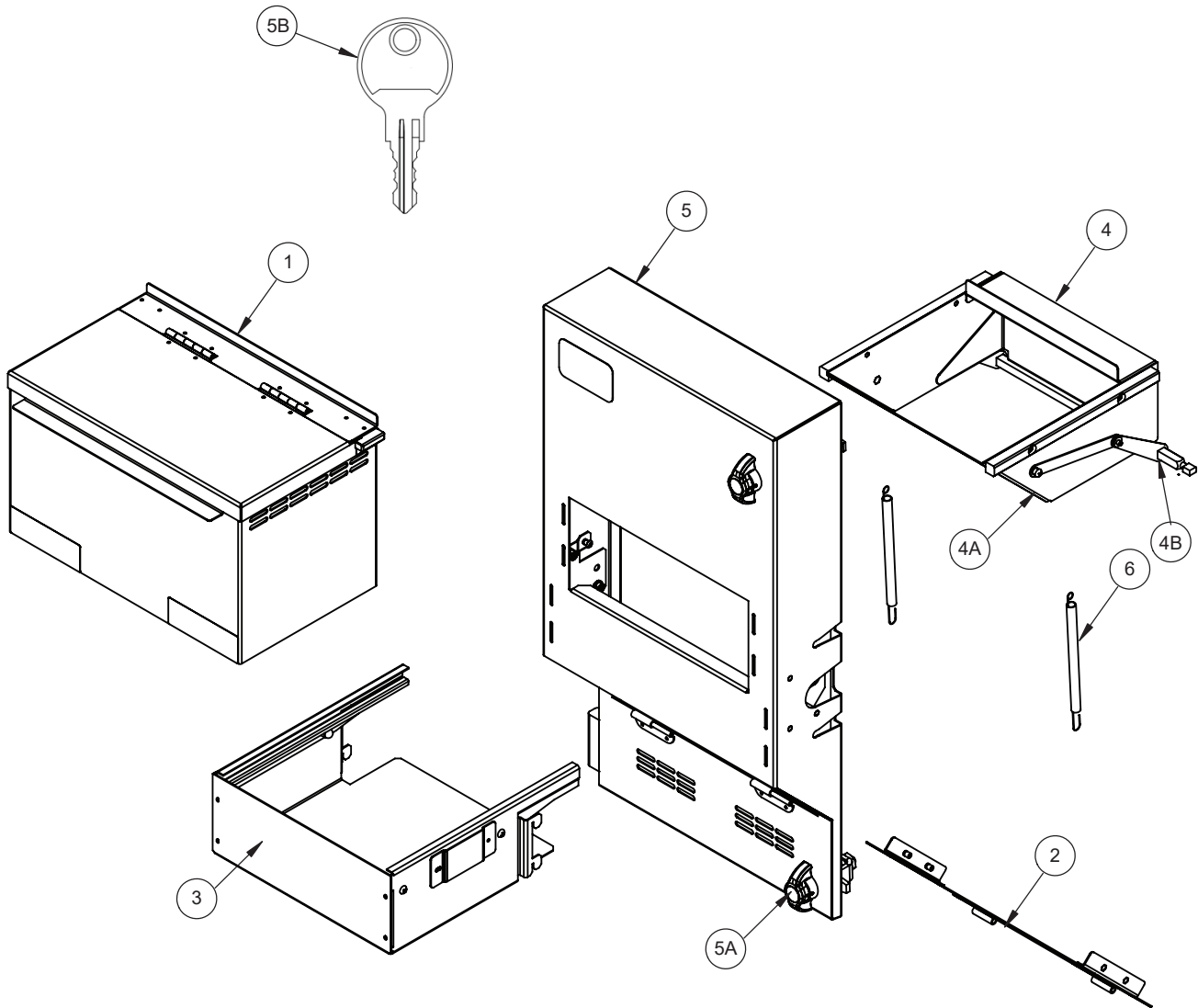

Item	P/N	Description	QTY
1	84006	ASSEMBLY, DRAWER AND LID	1
2	83921	RAMP BASKET PFA	1
3	83920	ASSEMBLY, DRAWER SLEEVE	1
4	83918	ASSEMBLY, SHOVEL DRAWER PFA	1
4	84370	ASSEMBLY, SHOVEL DRAWER FIREHOUSE SUBS	1
4A	83913	ASSEMBLY, SHOVEL	1
4B	83222	ARM UPPER DRAWER	2
4B	84371	ARM, UPPER DRAWER FIREHOUSE SUBS	1
5	84039	ASSEMBLY, FRONT PANEL PFA	1
5A	83059	LATCH, VICE WING NON-LOCKING	2
5B	83848	SPARE LOCK KEY PERFECT FRY (PAIR)	1
NS	83060	LATCH, VICE WING LOCKING	OPTION
NS	83066	SPRING, BASKET RAMP PFA	2

PFC DOOR

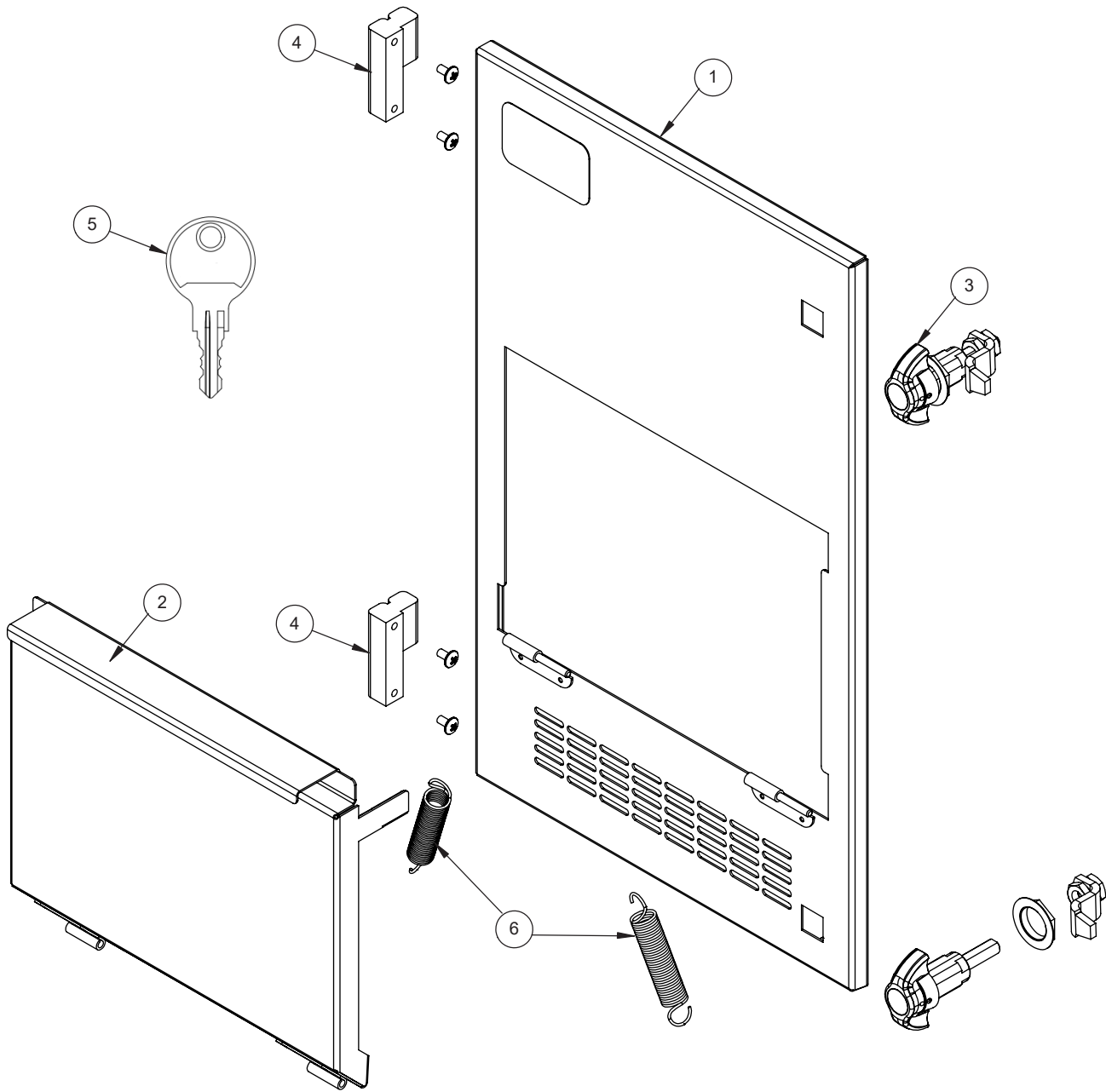

Item	P/N	Description	QTY
1	84177	PANEL FRONT COMPLETE	
2	84124	PANEL FRONT ASM	1
3	83059	LATCH, VICE WING NON-LOCKING	2
4	83271	HINGE, LIFT OFF	1
5	83848	SPARE LOCK KEY PERFECT FRY (PAIR)	1
NS	83060	LATCH, VICE WING LOCKING	OPTION
6	83698	KIT DOOR SPRING PFC (2pc)	1
NS	84160	DECAL, PF LOGO, SMALL	1

PERFECT FRY ELEMENT LIFT

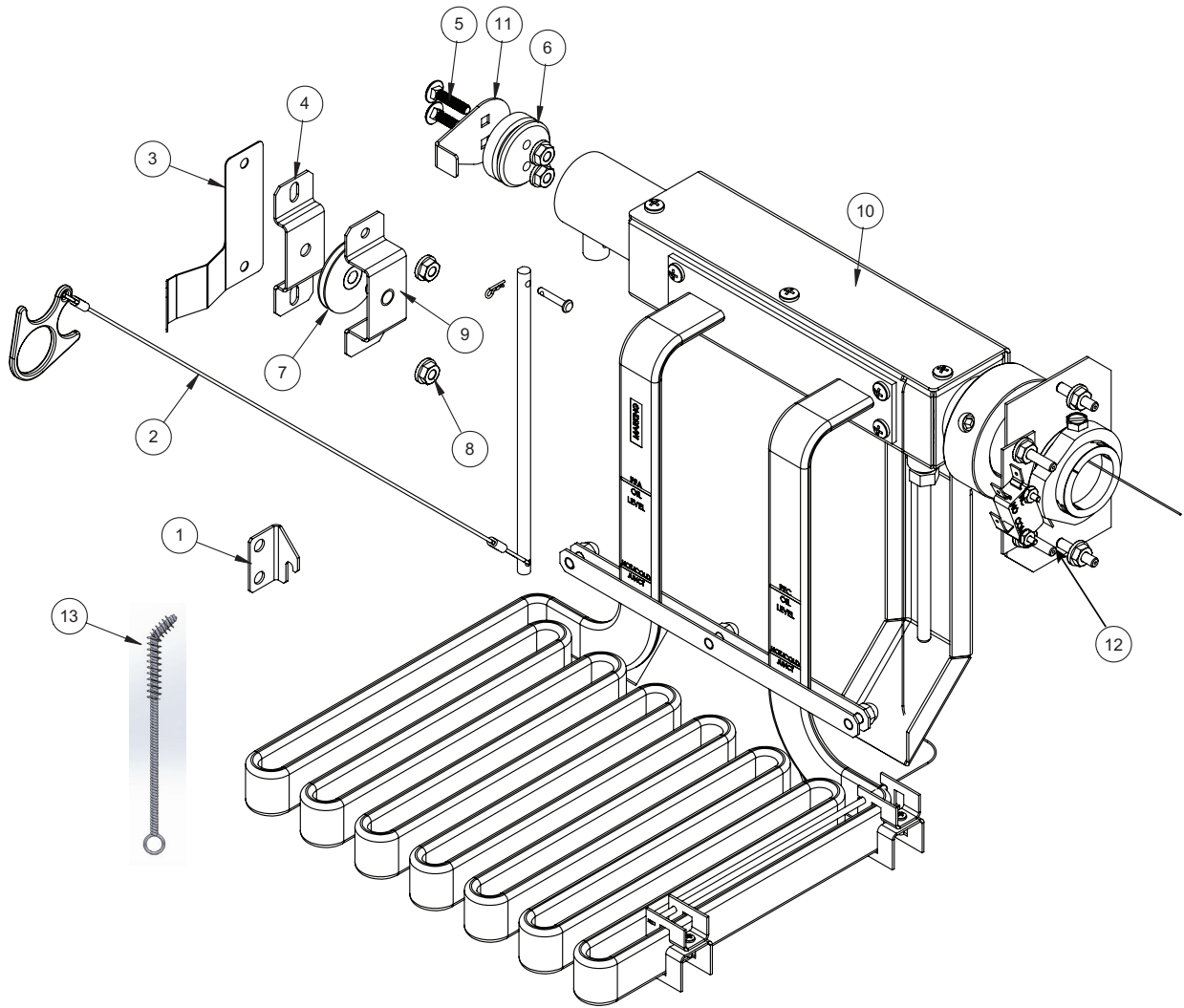

Item	P/N	Description	QTY
1	84052	HOOK, PULLEY SYSTEM, PFA	1
2	84088	CABLE ASM, ELEMENT LIFT, PFA	1
3	84108	BRACKET, ELEMENT PULL RETAINER	1
4	84214	INNER PULLEY BRACKET, PFA	1
5	84020	BOLT, CARRIAGE, 10-32 X 7/8	1
6	83973	BUSHING, INTERNAL PIVOT	1
7	84056	PULLEY, ELEMENT LIFT, PFA	1
8	83600	NUT, 10-32, SERRATED FLANGE	4
9	84213	OUTER PULLEY BRACKET, PFA	1
10	84060	ELEMENT ASM, PIVOTING, 7.3KW 208V	1
10	84061	ELEMENT ASM, PIVOTING, 7.3KW 230V	1
10	84062	ELEMENT ASM, PIVOTING, 5.0KW 230V	1
10	84063	ELEMENT ASM, PIVOTING, 5.0KW 208V	1
11	84054	STOP, PULLEY SYSTEM, PFA	1
12	84192	ELEMENT POSITION SWITCH	1
13	84390	BRUSH, ANGLED CLEANING (OPTIONAL)	1

PFA/PFC CONTACTOR ASSEMBLIES

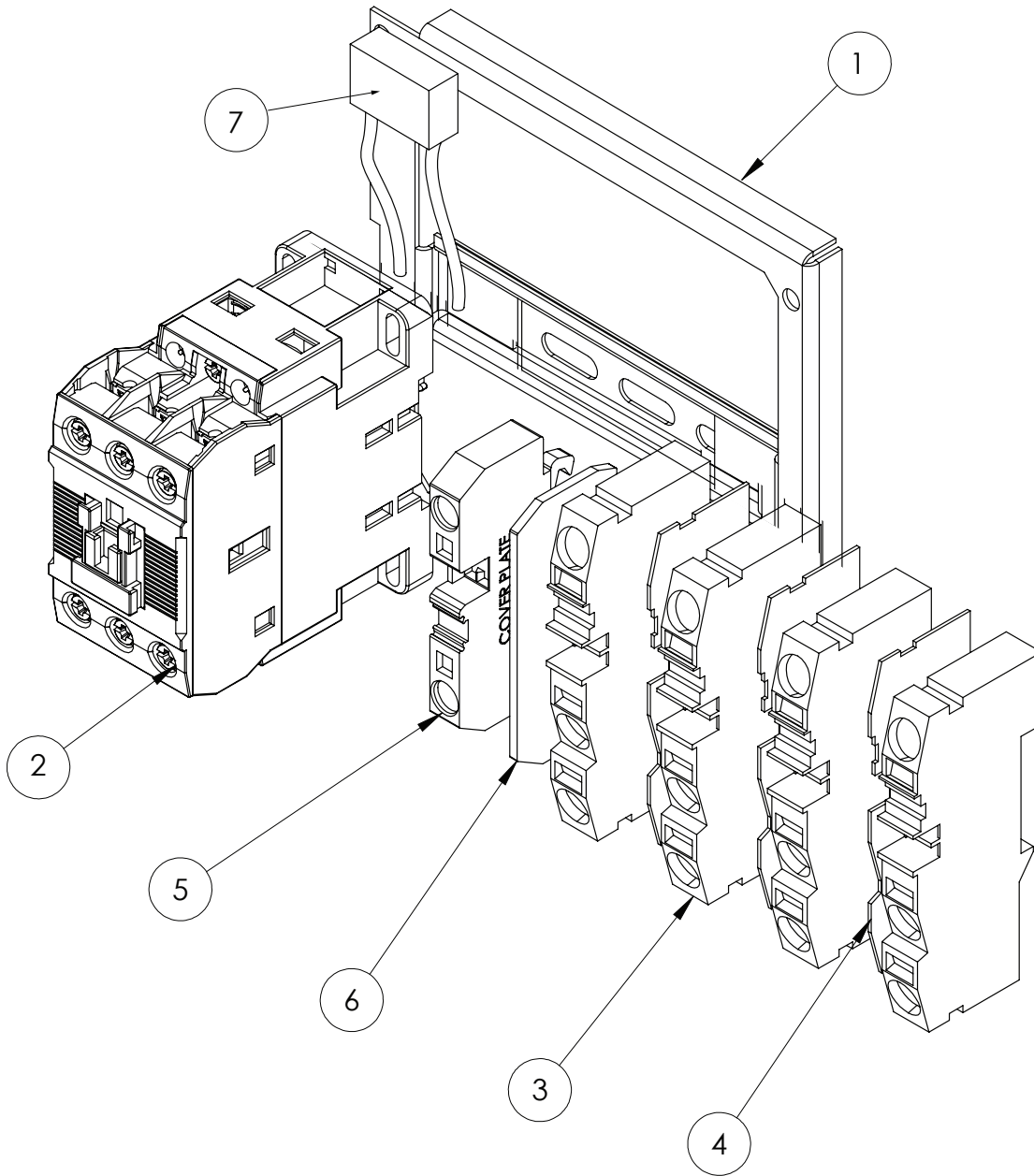

Item	New P/N	Description	QTY
1	84008	HV PANEL	
2	R11087	CONTACTOR, 3 POLE, 40A, 240VAC	
3	83975	WAGO TERM BLOCK 3POS 20-4AWG	
4	83974	WAGO, TB COVER PLATE	
5	52204	TERMINAL BLOCK, GROUND	
6	52203	END PLATE	
7	84203	SNUBBER, 0.1MFD, 22OHM	

PFA ELECTRICAL CAVITY

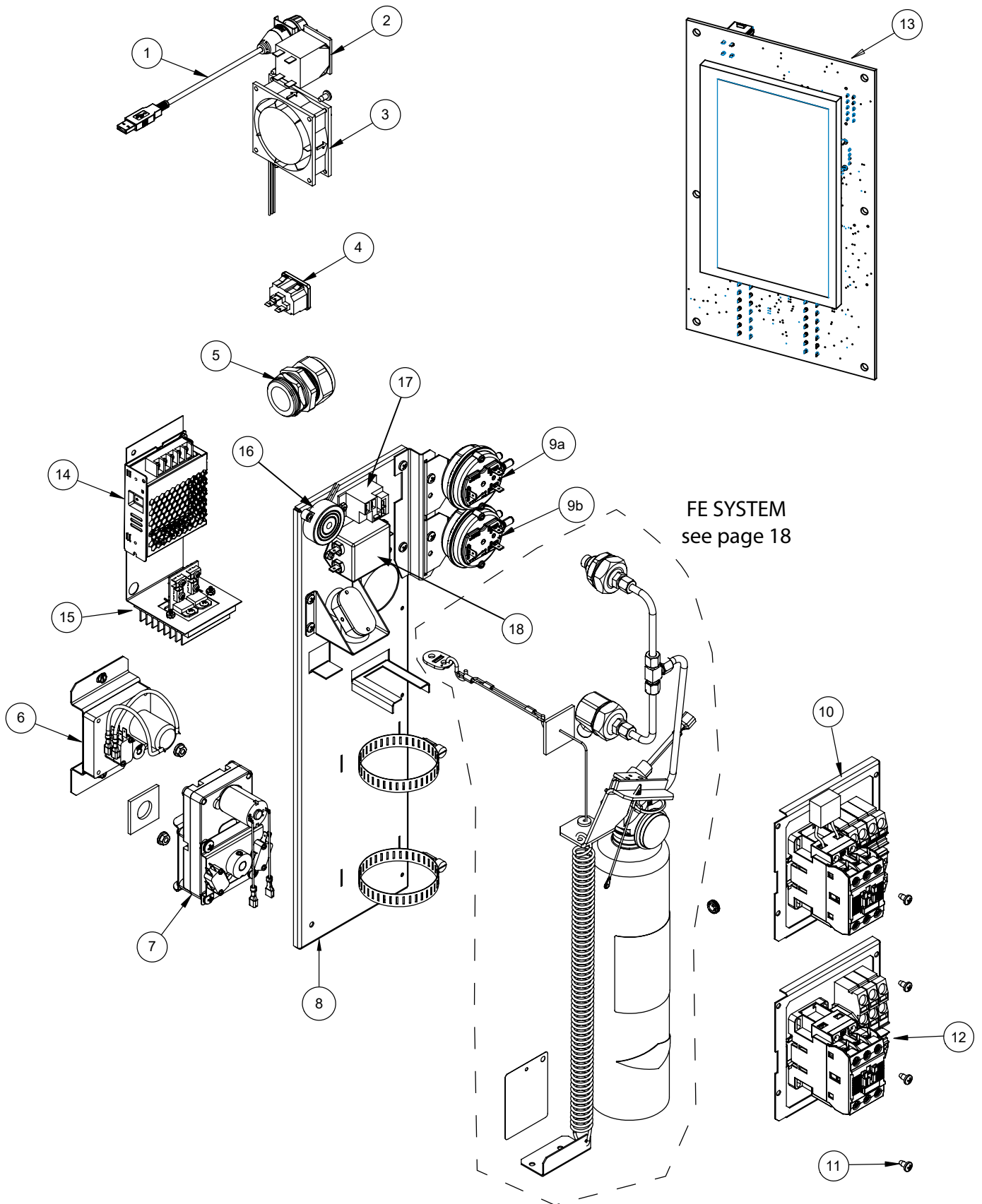

PFA ELECTRICAL CAVITY

Item	P/N	Description	QTY
1	52160	USB CABLE	1
1	52161	COVER, USB, XR8G	1
2	39688	CIRCUIT BREAKER	1
3	83423	CONTROL COOLING FAN, 12V	1
4	83213	PLUG, HEAT LAMP	1
5	39940	CORD GRIP, 7" NPT X 0.071-0.098	1
6	84042	MODULE, MOTOR, DRAWER, PFA	1
7	84406	MODULE, MOTOR, BASKET, PFA	1
8	84043	PANEL ASSY, PFA FE	1
9a	100737	PRESSURE SWITCH SPDT .40WC	
9b	84086	PRESSURE SWITCH SPDT .1	
10	84075	TOP, HV PANEL, 1 PH, PF (K1)	1
11	4812	SCREW, MACH, #10 x 3/8	4
12	84078	BOTTOM, HV PANER, 1/P/3P DELTA, PF	1
13	84326	PRGM CTRL, PFA, 5000W	1
13	84327	PRGM CTRL, PFA, 7300W	1
13	84354	PRGM CTRL, PFA, 7300W, FHS	1
13	84412	PRGM CTRL, PFA 5000W, FHS	1
14	100064	POWER SUPPLY, 12V 50W OUTPUT	1
15	83375	ASSEMBLY, SCR BOARD	1
16	83377	BUZZER, E BOX CONTROL	1
17	83552	RELAY, DC 20A 12V	1
18	53902	EMI FILTER	1
NS	83375	SCREW	

PFC ELECTRICAL CAVITY

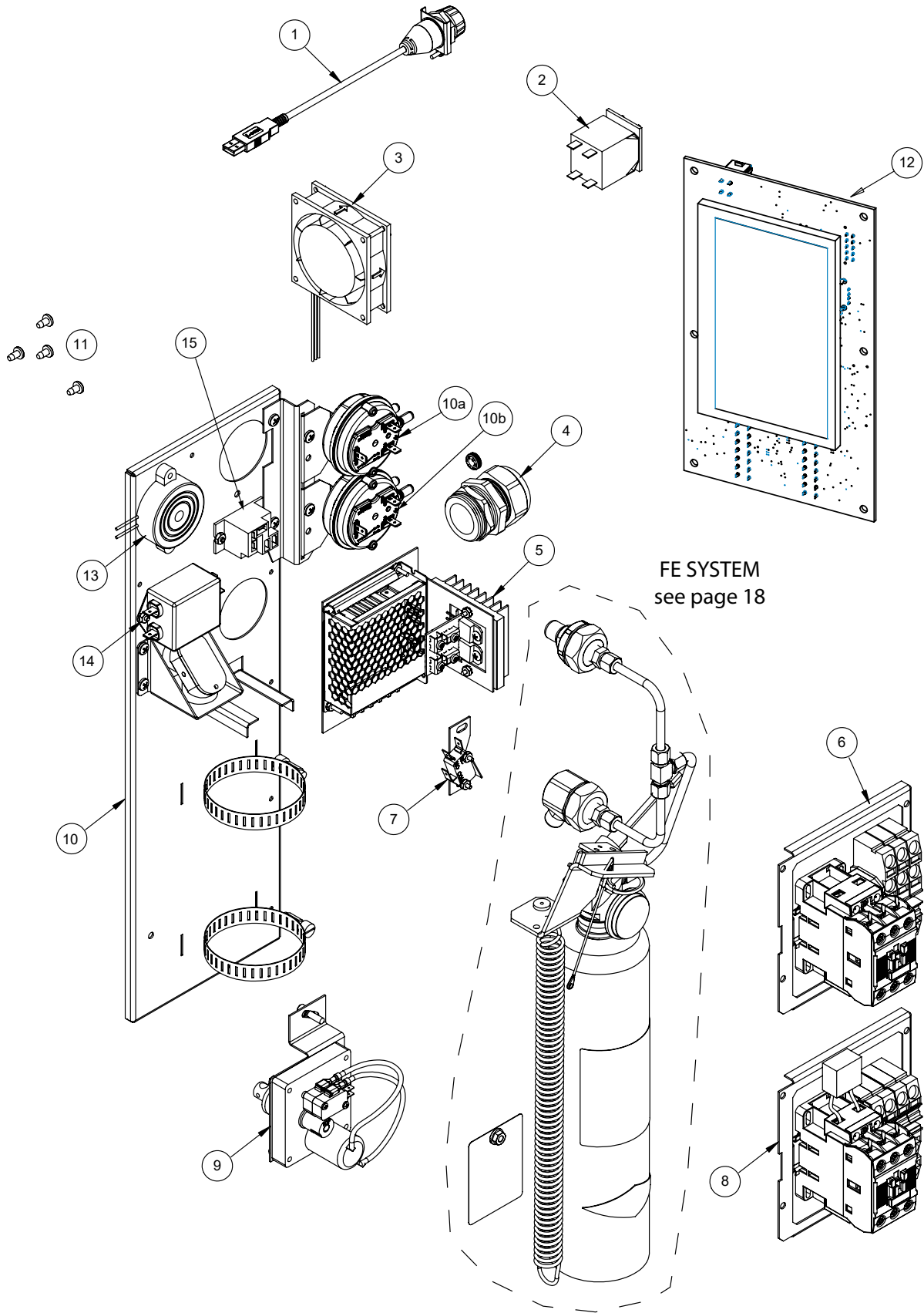

PFC ELECTRICAL CAVITY

Item	P/N	Description	QTY
1	52161	COVER, USB, XR8G	1
1	52166	USB CABLE	1
2	39688	CIRCUIT BREAKER	1
3	83423	CONTROL COOLING FAN, 12V	1
4	39940	CORD GRIP, 7" NPT X 0.071-0.098	1
5	84183	PFC SSR & TOWER SUPPLY BRACKET	1
6	84078	BOTTOM, HV PANER, 1P/3P DELTA, PF	1
7	84192	ASM, ELEMENT POSITION SWITCH	1
8	84075	TOP, HV PANEL, 1 PH, PF (K1)	1
9	84180	PFC BASKET MOTOR	1
10	84176	PFC, FE PANEL ASM	1
10a	100737	PRESSURE SWITCH SPDT .40WC	
10b	84086	PRESSURE SWITCH SPDT .1WC	
11	4812	SCREW, MACH, #10 x 3/8	4
12	84324	PRGM CTRL, PFC, 5000W	1
12	84325	PRGM CTRL, PFC, 7300W	1
13	83377	BUZZER CONTROL	1
14	53902	EMI FILTER	1
15	83552	RELAY, DC 20A 12V	1
NS	83375	SCREW	1

FIRE SYSTEM

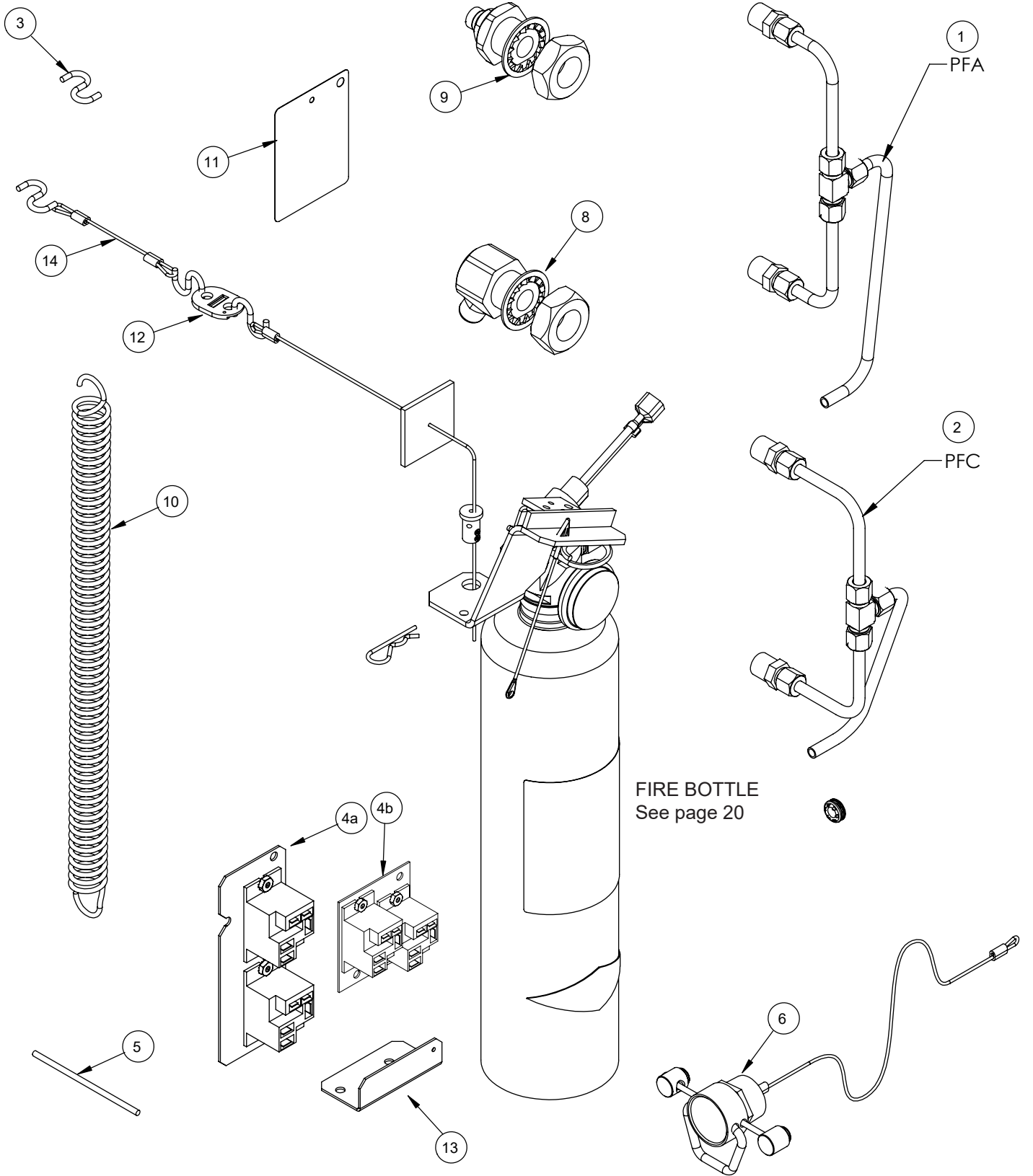

FIRE SYSTEM

Item	P/N	Description	QTY
1	83972	WET CHEM DIST TALL EXT, PFA	-
2	84135	WET CHEM DIST TALL EXT, PFC	-
3	83088	S HOOK	-
4a	84046	REMOTE ALARM, PFA	-
4b	84181	REMOTE ALARM, PFC	-
5	83091	BREAK ROD, RED, MANUAL PULL	-
6	83096	ASSY, MANUAL PULL WITH CABLE	-
8	83110	ASSY, LOWER NOZZLE, WET CHEM	-
9	83111	ASSY, UPPER NOZZLE, WET CHEM	-
10	83787	SPRING, FIRE MASTER	-
11	83350	FIREMASTER INSPECTION TAG	-
12	83658	LINK, FUSIBLE, 280°F	-
13	83946	BRACKET, SPRING	-
14	83939	FUSABLE LINK CABLE	-

* Per NAFPA 17A fusible links must be replaced every 6 months

***DSA & DSE MODELS EXCLUDE FIRE SUPPRESSION SYSTEM.
DISREGARD FOR SERVICE OF THESE MODELS**

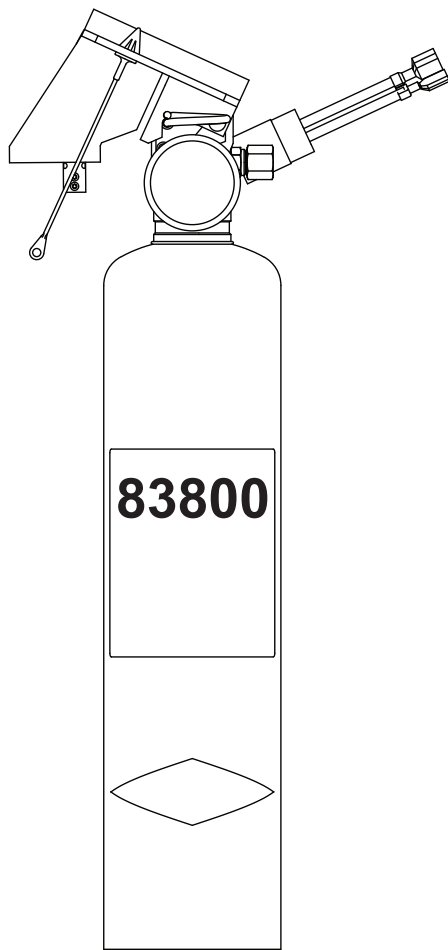

3" Diameter

83807	<p>FIRE EXTINGUISHER REPLACEMENT AFTER DISCHARGE KIT This kit is used to replace new style fire extinguishers that have discharged in the event it can not be rebuilt and recharged by a local Amerex distributor. (Requires Fire Extinguisher P/N 83800)</p>
83804	<p>FIRE EXTINGUISHER RECHARGE KIT This kit is used to rebuild and recharge an existing new style fire extinguisher. To be done by a local Amerex dealer.</p>
83800	<p>FIRE EXTINGUISHER</p>

***DSA & DSE MODELS EXCLUDE FIRE SUPPRESSION SYSTEM.
 DISREGARD FOR SERVICE OF THESE MODELS**

OPTIONAL PERFECT FILTER



Item	P/N	Description	QTY
1	84080	PERFECT FILTER	1
2	84081	REPLACEMENT FILTERS, PERFECT FILTER (100x)	1
3	84082	OIL QUALITY SENSOR, FT440, HAND HELD	1
4	84083	OIL QUALITY SENSOR BOARD STORAGE BRACKET	1