

**Novy Mini Pureline 120 cm  
White**

EAN 5414425273447

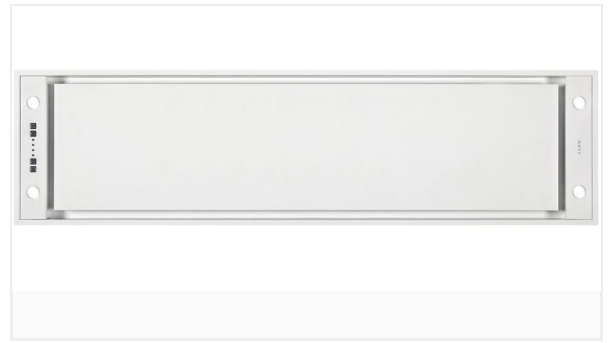

### Energy Label

Energy efficiency class (EEIhood)	A+
Annual Energy Consumption (AEChood)	34
Fluid dynamic efficiency class (FDEhood)	A
Lighting efficiency class (LEhood)	A
Grease filtering efficiency class (GFEhood)	E

### Functions and features

Fan Motor Location	Integrated
Sound absorber	Integrated
Recirculation	Optional
InTouch function	Standard
Auto stop	●
Delayed switch off	●
Grease filter	7400020
Number of Grease Filters	1
Grease filter cleaning indication	●
Recirculation filter cleaning indication	●
Control method	Remote control, Push buttons
Number of Fan Speeds	3 + power
Automatic Power revert (minutes)	6 m

### Dimensions

Product Dimensions (WxDxH) (mm)	116 Millimeter X 301 Millimeter X 330 Millimeter
Width flange (mm)	10
Dimensions cut-out opening (WxD) (mm)	1145 x 286
Advised mounting height induction hobs (Hmin-Hmax) (mm)	650 - 950
Advised mounting height gas hobs (Hmin-Hmax) (mm)	650 - 950
Advised mounting height above ceramic hobs (Hmin-Hmax) (mm)	600 - 950
Diameter duct	150 mm
Position exhaust (to be delete)	Top, right, left, front, back

## Lighting

Functional Lighting Type	LED
Functional light dimmable	●
Soft-ON/OFF	●
Number of Functional Lights	4
Total energy consumption functional light (W)	8 W
Color functional light (K)	2700/4000

## Airflow and noise levels

Free airflow (m <sup>3</sup> /h)	815 m <sup>3</sup> /h
Airflow duct out speed 1 (m <sup>3</sup> /h)	245,40 m <sup>3</sup> /h
Airflow duct out speed 2 (m <sup>3</sup> /h)	388,50 m <sup>3</sup> /h
Airflow duct out speed 3 (m <sup>3</sup> /h)	464,80 m <sup>3</sup> /h
Airflow duct out max powerspeed (m <sup>3</sup> /h) (Qboost)	614,90 m <sup>3</sup> /h
Max pressure duct out at minimum speed	82 Pa
Max pressure duct out at max continuous speed	324 Pa
Sound pressure duct out speed 1	27 dBA
Sound pressure duct out speed 2	37 dBA
Sound pressure duct out speed 3	41 dBA
Sound power duct out speed 1	39 dBA
Sound power duct out speed 2	49 dBA
Sound power duct out speed 3	53 dBA

## Technical specifications

Electrical Total Wattage	121 W
Electrical Volts	220-240V
Electrical frequency	50-60 Hertz
Power consumption in stand-by-mode (Ps) (W)	0,35 W
Product Weight (kg)	13 kg
Length power supply cable	1,30 m

## Dimensions

1

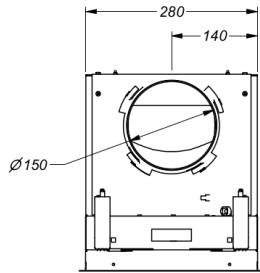

2

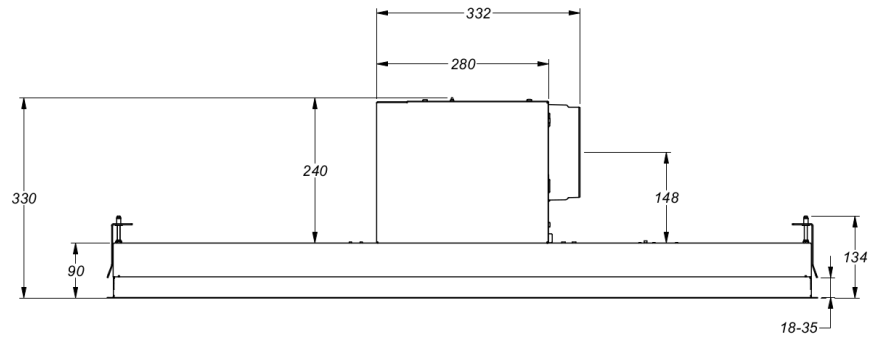

3

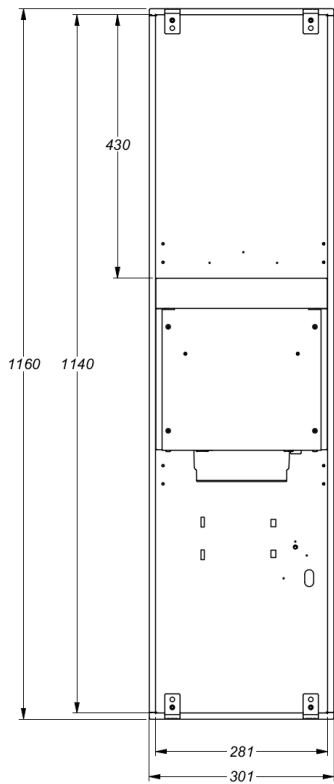

4

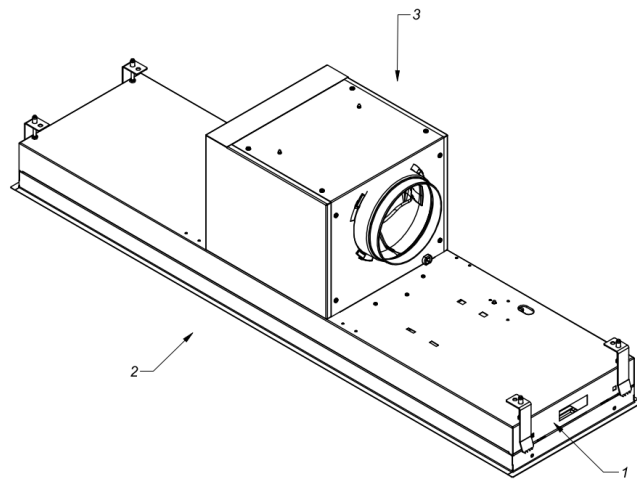

Accessories

---

**700094**

Extension cable for remote motor - 5 m

**730055**

Monoblock replacement filter

**790055**

Monoblock replacement filter

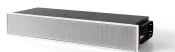
**7931400**

Exhaust box with monoblock filter

**7932400**

Recirculation box black with monoblock, H140 mm

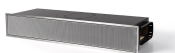
**7933400**

Recirculation box with monoblock filter