



IMV-4E

ImVection Oven

IMV-4E



Optional base & casters.
Unit will bolt directly to base without legs

OPTIONS AND ACCESSORIES

(AT ADDITIONAL CHARGE)

- 24" (610mm) Stand w/Locking Casters (2 Locking)
- Extra Core Probe
- Open Kitchen SAP (Secure Access Point)

(AT NO ADDITIONAL CHARGE)

- Left Hand Hinge Door



NSF/ANSI 4
E538399

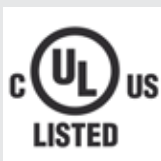

E538398



Project _____

Item No. _____

Quantity _____

Each chamber will accept 13" x 18" standard half-size baking pans in front-to-back-position, 16" round pizza pans, or full size 12 x 20 hotel pan. All data is shown per oven section, unless otherwise indicated.

Refer to operator manual specification chart for listed model names.

EXTERIOR CONSTRUCTION

- Stainless steel front, top and sides
- Aluminized rear panels
- Powder coated control panel and top cover
- Two independent doors with removable inner glass for easy cleaning

INTERIOR CONSTRUCTION

- 4 chambers with individual heat controls
- Two Jet plate assemblies per chamber (top/bottom) removable for cleaning
- Bright, long lasting light in each chamber - recessed
- 304 Stainless steel chamber interior
- Hidden temperature thermocouple per chamber

OPERATION

- Temperature range of 300°F - 525°F (149°C - 274°C)
- Able to maintain 175°F (79°C) temperature differential between chambers
- Variable temperature and air speed per chamber
- 2 Distinct cook modes: Impingement / Convection
- Cook mode automatically assigned according to selected temperature
- Lights indicate selected chamber for cook and signal completed cook
- USB connection for recipe upload or download

STANDARD FEATURES

- Ventless via use of catalyst per chamber
- 7" (178mm) Capacitive Touchscreen in landscape format
- Open Kitchen
- Top mounted controls for serviceability
- Meat probe cooking function - single chamber, selectable
- Chamber dimensions: 5.4" (137mm) Height (no rack), 4.4" (111mm) Height (w/rack), 16.75" (425mm) Wide, 21.5" (546mm) Depth
- Adaptive power management optimizes cooking efficiency and power use
- Dual independent heating elements for accurate temperature control per chamber
- Pendulum door latch for positive engagement
- 4 variable speed blowers
- Adjustable Legs, 4" - 6.5" (101mm - 165mm) adjustable range
- Low emissivity coating on inner doors for energy efficiency

* For all international markets, contact your local distributor.

NOTE: The company reserves the right to make substitutions of components without prior notice

www.blodgett.com

42 Allen Martin Drive, Essex Junction, VT 05452
Phone: (802) 658-6600 | Fax: (802) 864-0183



IMV-4E

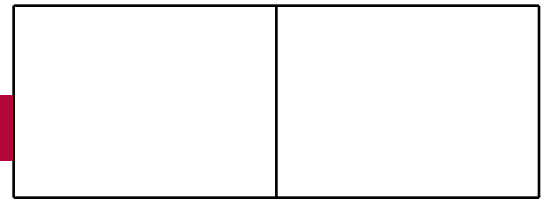

APPROVAL/STAMP

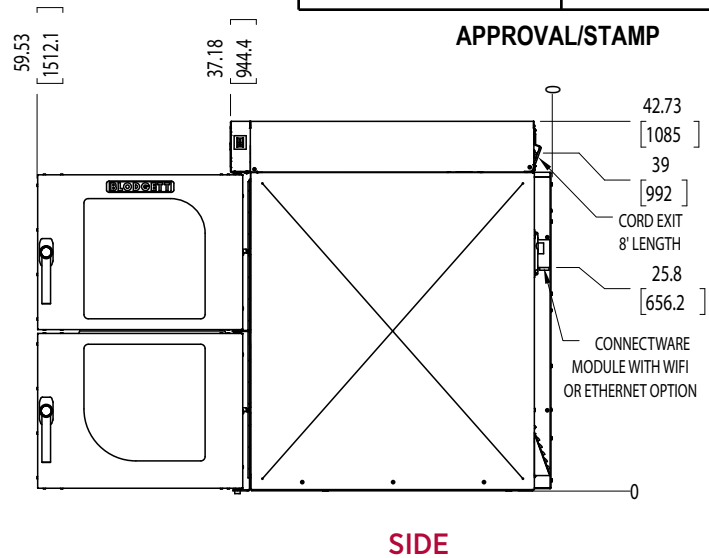
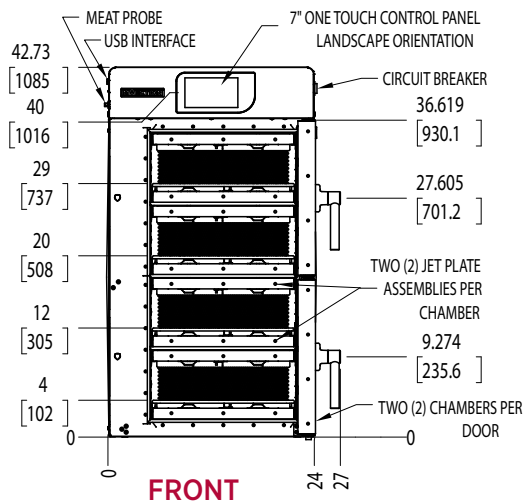

SHORT FORM SPECIFICATIONS Provide Blodgett ImVection oven model IMV-4E with four independently controlled cooking chambers in a unibody construction. Each chamber shall have fully welded 304 stainless steel liner and shall accept half-size sheet pans. Two independent hinged doors shall have removable inner glass for easy cleaning. Unit shall be heated by eight tubular heating elements consisting of four operational pairs, one pair per chamber. Each chamber has an independent air distribution system via a dual inlet, dual outlet blower wheel powered by a variable speed 1/2hp motor with thermal overload protection. Each chamber shall be fitted with a bright Lamp, two jet plate assemblies, and a wire rack. Unit shall have programmable control capable of storing 100+ multi-stage recipes. Unit will provide two distinct cook modes, Impingement and Convection and will be automatically assigned according to selected temperature. Unit shall maintain up to a 175° temperature differential between adjacent chambers with a temperature range of 300°F - 525°F. Circuit breaker on side panel for easy service. 1 year parts and 1 year labor warranty. Provide options and accessories as indicated.

DIMENSIONS

- Floor space** 24" W x 37.18" D (610mm W x 945mm D)
- Unit Height** 48.75" (1238mm) H W/ STANDARD 6" (152mm) ADJUSTABLE LEGS
- With Stand** 67" (1702mm) H W/24" (610mm) STAND ON CASTERS
- Interior** 16.75" W x 21.5" D x 5.4" H (4.4" H w/ rack)

PRODUCT CLEARANCE

From combustible and non-combustible construction

- Oven sides** Required 4" (101mm) clearance
- Oven back** Required 2" (50mm) clearance to oven
- Oven Top** Blodgett recommends 18" (457mm) for servicing

VENTLESS/CATALYST

- UL (KNLZ) listed for ventless operation
- EPA test method 202, emissions of grease laden vapors
 - Product: Pepperoni Pizza
 - Results: 1.19 mg/m³
 - Product: Raw Quartered Chicken
 - Results: 3.36 mg/m³
 - Ventless Requirement: <5.00 mg/m³
- Heat gain: 1,300.8 Watts (4,440 BTU)

SHIPPING INFORMATION

- Approx. Weight** Single 650lbs (295kg)
- Crate Size** 53.5"H x 30.5"W x 47.5"D (425mm W x 546mm D x 137mm H (111mm H w/ rack))

POWER SUPPLY

VAC	Hz	Phase	kW	Amps (L1-L2-L3)
208-240	60	3	17.5	42-49
VAC (L-N/L-L)	HZ	PHASE	KW	AMPS ([L1,L2,L3], N)
220-240/380-415	50/60	3N	17.5	27-32, 2-4

This oven uses a variable frequency drive, which can produce high frequency electrical noise. Some units must be hard wired to avoid false positives on ground fault devices susceptible to errors from electrical noise. All installations must comply with local and national codes.

CORD & PLUG

- 1 NEMA 15-50
- No cord supplied on 3N phase configured units

MINIMUM ENTRY CLEARANCE

- Uncrated** 24" (610mm)
- Crated** 30.5" (775mm)