

## ELECTRIC PEDESTAL KETTLE



- EP-20
- EP-25
- EP-30
- EP-40
- EP-60
- EP-80
- EP-100

### OPERATION SHALL BE BY:

Electrically, self-generating closed steam system operating at 50 psi equipped for operation on:

- 208 VAC, 1 phase, 50/60 Hz (12 to 18 kW only)
- 208 VAC, 3 phase, 50/60 Hz
- 220 VAC, 1 phase, 50/60 Hz (12 to 18 kW only)
- 220 VAC, 3 phase, 50/60 Hz
- 240 VAC, 1 phase, 50/60 Hz (12 to 18 kW only)
- 240 VAC, 3 phase, 50/60 Hz
- 380/220 VAC, 3 phase, 50/60 Hz 4 wire
- 415/240 VAC, 3 phase, 50/60 Hz 4 wire

### OPTIONS & ACCESSORIES AT ADDITIONAL COST

- |  |   |  |
|--|---|--|
| <input type="checkbox"/> 3" (76 mm) draw-off valve (TVS-3) with perforated strainer (TPS-) | <input type="checkbox"/> Etched gallon markings (GM-)                         | <input type="checkbox"/> Single pantry faucet with swing spout (SF-18) |
| <input type="checkbox"/> 24 kw on 40, 60, 80 gallon  | <input type="checkbox"/> Etched litre markings(LM-)                           | <input type="checkbox"/> Perforated strainer for draw-off valve (TPS-) |
| <input type="checkbox"/> 33 kw on 60, 80, 100 gallon                                       | <input type="checkbox"/> Correctional package                                 | <input type="checkbox"/> Double pantry faucet with swing spout (DF-18) |
| <input type="checkbox"/> 380 VAC, 3 Phase, 50/60 Hz  | <input type="checkbox"/> Solid state thermostat (SST-E)                       | <input type="checkbox"/> Draw-off valve hose kit (DVHK-)               |
| <input type="checkbox"/> 415 VAC, 3 Phase, 50/60 Hz  | <input type="checkbox"/> One piece lift off cover (C-)                        | <input type="checkbox"/> Calibrated thermostat dial "F"                |
| <input type="checkbox"/> 480 VAC, 3 Phase, 50/60 Hz  | <input type="checkbox"/> Triple basket assembly (TBA-)                        | <input type="checkbox"/> Calibrated thermostat dial "C"                |
| <input type="checkbox"/> 600 VAC, 3 Phase, 50/60 Hz  | <input type="checkbox"/> Solid stainless steel disc for draw-off valve (TSS-) | <input type="checkbox"/> Kettle heat shield (KHS-)                     |
| <input type="checkbox"/> Two piece hinged stainless steel cover (2PHC- 40 gallons and up)  | <input type="checkbox"/> Graduated measuring strip (CMS-)                     |  |
|  | <input type="checkbox"/> Strainer hook (SH)                                   |  |

### STANDARD CONSTRUCTION SPECIFICATIONS

Shall be a Crown model EP-20, EP-25, EP-30, EP-40, EP-60, EP-80 or EP-100, self-generating, electric, pedestal kettle, ASME Code stamped, National Board Registered, c-CSA-us and NSF certified.

A double wall kettle interior shall form a steam jacket around the lower 2/3 of the kettle. The jacket enclosure shall contain distilled water which is factory sealed.

The bottom of the kettle shall be of hemispherical design for superior heat circulation.

Pedestal base shall have four 7/16 of an inch holes evenly spaced for securing unit to floor.

Construction shall be all welded #4 finish stainless steel, type 304.

The interior liner shall be standard 316 for high acid content cooking.

The controls shall be integrally mounted and shall include a power switch, thermostat, pilot light, low water light, vacuum/pressure gauge, safety relief valve and low water shut off.

Faucet bracket standard.

The kettle shall be standard with removable elements.

Convenience features shall include a 2" (50 mm) sanitary draw-off valve with perforated strainer and spring assist hinged stainless steel domed cover.

The kettle shall operate in a temperature range of 165°F to 285°F (74°C to 140°C) at a maximum pressure of 50 psi (345 kPa).

Includes faucet bracket.



Approval Notes: \_\_\_\_\_

\_\_\_\_\_

EP

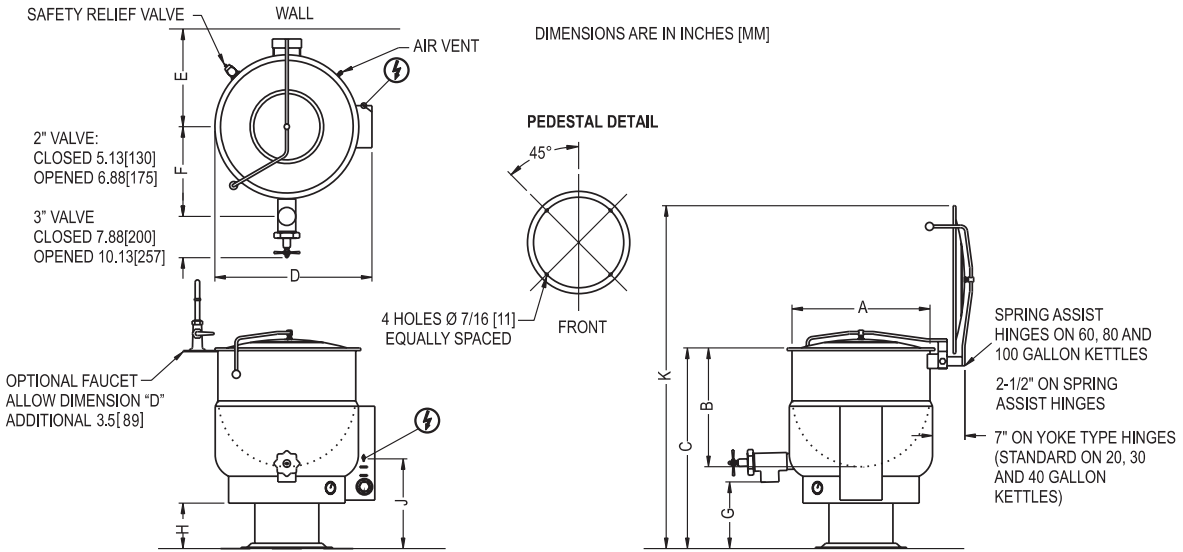

**SERVICE CONNECTIONS**

– ELECTRICAL CONNECTION : to be specified on data plate

**DIMENSIONS**

MODEL	CAPACITY	UNITS	A	B	C	D	E	F(2")	F(3")	G(2")	G(3")	H	J	K
EP-20	20 gallons (76 liters)	in (mm)	21" (533)	18" (457)	38" (965)	25.25" (641)	18.5" (470)	14.75" (375)	15.5" (394)	18" (457)	17.13" (435)	13.38" (340)	20.75" (527)	60.5" (1537)
EP-25	25 gallons (95 liters)	in (mm)	21" (533)	21.25" (540)	37.25" (946)	25.25" (641)	18.5" (470)	14.75" (375)	15.5" (394)	14.12" (358)	13.13" (333)	9.5" (241)	17" (432)	58.75" (1492)
EP-30	30 gallons (114 liters)	in (mm)	24" (610)	20" (508)	38" (965)	28.25" (718)	20" (508)	16" (406)	16.5" (419)	15.75" (400)	15" (381)	11.25" (286)	18.88" (479)	63.5" (1613)
EP-40	40 gallons (152 liters)	in (mm)	26" (660)	22.5" (572)	38" (965)	30.25" (768)	21" (533)	17" (432)	18" (457)	13.5" (343)	13.5" (343)	8.88" (225)	16.38" (416)	65" (1651)
EP-60	60 gallons (227 liters)	in (mm)	29.5" (749)	26" (660)	42" (1067)	33.75" (857)	20.63" (524)	18" (457)	19.25" (489)	13.88" (352)	12.88" (327)	9.63" (244)	17.13" (435)	75" (1905)
EP-80	80 gallons (303 liters)	in (mm)	33" (838)	28" (711)	45" (1143)	37" (940)	22.38" (568)	19.5" (495)	20.5" (521)	14.88" (378)	13.88" (352)	11.25" (286)	18.63" (473)	81" (2058)
EP-100	100 gallons (379 liters)	in (mm)	35.5" (902)	30" (762)	48" (1219)	40" (1016)	23.63" (600)	21.5" (546)	22.5" (572)	15" (381)	14.5" (368)	13" (330)	20.5" (521)	87" (2210)

**ELECTRICAL CHARACTERISTIC**

AVAILABLE kW		
MODEL	STANDARD	OPTIONAL
EP-20,25	12	N/A
EP-30	15	N/A
EP-40	18	24
EP-60	18	24 or 33
EP-80	18	24 or 33
EP-100	24	33

AMPS PER LINE								
kW	PHASE	208V	220V	240V	380V	415V	480V	600V
12	1	57.7	54.5	50.0	N/A	N/A	N/A	N/A
	3	33.3	31.5	28.9	18.2	16.7	14.4	11.6
15	1	72.1	68.2	62.5	N/A	N/A	N/A	N/A
	3	41.6	39.4	36.1	22.8	20.9	18.0	14.5
18	1	86.5	81.8	75.0	N/A	N/A	N/A	N/A
	3	50.0	47.2	43.3	27.3	25.0	21.7	21.7
24	3	66.6	63.0	57.7	36.5	33.4	28.9	23.1
33	3	91.6	86.6	79.4	50.1	45.9	39.7	31.8

**SPECIFICATIONS**

MODEL	CAPACITY	
EP-20	20 Gallon	76 Liter
EP-25	25 Gallon	95 Liter
EP-30	30 Gallon	114 Liter
EP-40	40 Gallon	151 Liter
EP-60	60 Gallon	227 Liter
EP-80	80 Gallon	303 Liter
EP-100	100 Gallon	379 Liter

MODEL	SHIPPING WEIGHT	MINIMUM CLEARANCE	
EP-20	196 lbs. [89 kg]	SIDES BACK	3" [76 mm] 3" [76 mm]
EP-25	200 lbs. [91 kg]		
EP-30	226 lbs. [103 kg]		
EP-40	255 lbs. [116 kg]		
EP-60	390 lbs. [177 kg]		
EP-80	445 lbs. [202 kg]		
EP-100	480 lbs. [218 kg]		

**INTENDED FOR COMMERCIAL USE ONLY.  
NOT FOR HOUSEHOLD USE.**

