



ELECTRIC STEAM COMPARTMENT COOKER WITH 2 KETTLES WITH ELECTRIC BOILER BASE



- ECX-2S-6-6
- ECX-2S-6-10
- ECX-10S-6-6
- ECX-10S-6-10

OPERATION SHALL BE BY:

Electrically heated steam boiler operating at 9 -11 psi (62 - 76 kPa) and rated at 42kW.

The controls shall be equipped for operation on 115 VAC, single phase 50/60 Hz.

Standard Features

- Water Treatment System
- Split water line
- CSD-1 boiler controls
- Automatic blowdown
- Flanged feet
- Drain tempering system for 140 degree temperature requirement (requires 1/2" cold water connection)



MODEL	DESCRIPTION	PAN CAPACITY PER COMPARTMENT			
		PAN DEPTH			
		1"	2-1/2"	4"	6"
ECX-2S-6-6	6 pan steamer with (2) 6 gallon kettles and 42 kW boiler.	6	3	2	1
ECX-2S-6-10	6 pan steamer with (1) 6 gallon and (1) 10 gallon kettle and 42 kW boiler.	6	3	2	1
ECX-10S-6-6	10 pan steamer with (2) 6 gallon kettles and 42 kW boiler.	10	5	3	2
ECX-10S-6-10	10 pan steamer with (1) 6 gallon and (1) 10 gallon kettle and 42 kW boiler.	10	5	3	2

OPTIONS & ACCESSORIES

- 48 kW (240 VAC, MIN)
- 220 VAC, 3 phase, 60 Hz
- 380 VAC, 3 phase, 60 Hz
- 415 VAC, 3 phase, 60 Hz
- 480 VAC, 3 phase, 60 Hz
- 240/415, 3 phase, 4 wire
- 220/380 VAC, 3 phase, 4 wire
- 208-240 VAC operation (specify voltage)
- 575 or 600 VAC, 3 Phase, 60 Hz (EBVS-3)
- Stainless steel rear panel (SSB-)
- Stainless steel frame (SSF-)
- Correctional package
- Load compensating timers (LCT)
- Etched gallon markings (GM-)
- Etched litre markings (LM-)
- Spray and rinse assembly
- Steam take-off kit (STOK)
- One piece lift off cover (C-)
- Lift out stainless steel basket (SSB-)
- Water in "Y" strainer (condenser feed)

STANDARD CONSTRUCTION SPECIFICATIONS

Shall be a Southbend Steam model ECX-2S-6-6, ECX-2S-6-10, ECX-10S-6-6 or ECX-10S-6-10, convection steamer complete with (2) 6 gallon kettles or (1) 6 and (1)10 gallon kettle on a modular electric steam boiler base, with stainless steel type 304 exterior and #4 finish, deck mounted faucet valve, swing nozzle and integral sink with common drain.

The convection steamer shall have doors with a removable inner liner of stainless steel, full perimeter gasket seal, outer shell of one piece, all welded, stainless steel, positive lock and seal mechanism and a stainless steel drip trough connected to the drain in order to collect condensate when doors are opened.

Each cooking chamber shall be constructed of all welded type 316 stainless steel, fully insulated and provided with removable stainless steel pan supports and shall be:

- ECX-2S: 13.875"W x 10.875"H x 19.875"D (352 mm x 276 mm x 504 mm).
- ECX-10S: 13.875"W x 17.375"H x 19.875"D (352 mm x 441 mm x 504 mm).

Steamer controls shall be accessible through a fully removable side panel and each compartment shall include a 60 minute mechanical timer with ready and cooking

pilot light and shall interrupt steam flow to the chamber when the compartment door is opened during cooking cycle and shall be reactivated when the door is closed.

An audible signal will sound at the end of the cooking cycle.

The cabinet base with electric boiler and controls shall be provided with full perimeter painted angle frame, reinforced kettle and boiler mountings, hinged doors with magnetic latch and 6" (152 mm) stainless steel legs fitted with 4 adjustable flanged feet for securing unit to the floor.

Boiler controls shall include automatic water level control, pressure gauge, water gauge glass, operating pressure control, safety high-limit pressure control, and safety relief valve.

Unit comes standard with a water treatment system, split water line, CSD-1 boiler controls, and automatic blowdown.

The boiler shall be ASME code stamped and National Board registered.

SEE REVERSE SIDE OF SPEC SHEET FOR WATER TREATMENT SYSTEM STATEMENTS



Approval Notes: _____

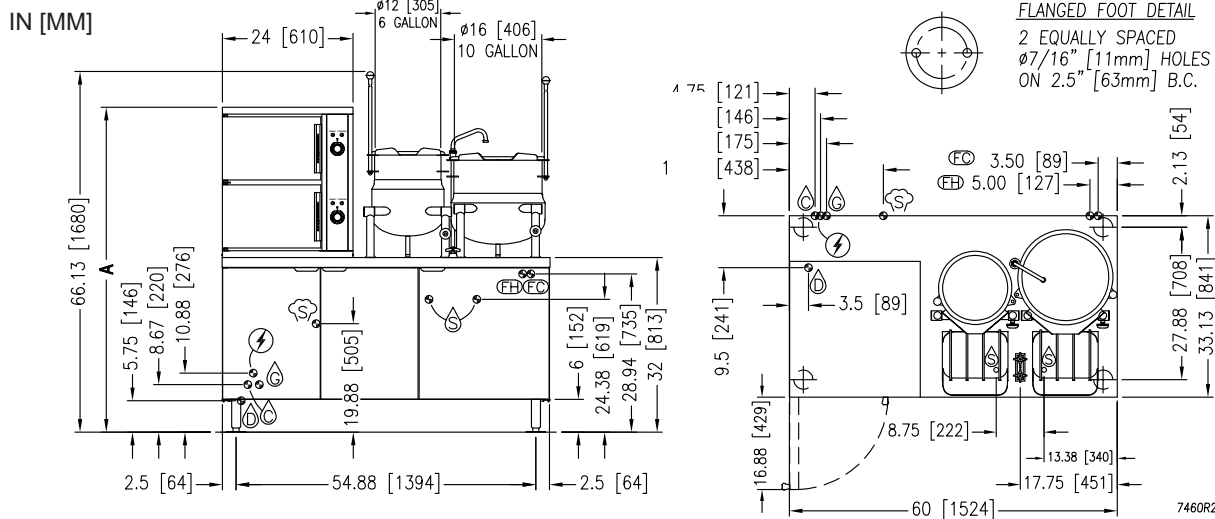

NOTE: SPLASH GUARD NOT SHOWN ON FRONT VIEW.

SERVICE CONNECTIONS

- ELECTRICAL CONNECTION: Field wiring electrical connection to be as specified on data plate.
- BOILER FEED WATER: 1/2" (13 mm) NPT at 25-50 PSI (170-345 kPa).
- CONDENSATE COLD WATER: 1/2" (13 mm) NPT at 25-50 PSI (170-345 kPa) (OPTIONAL)
- FAUCET COLD WATER: 3/8" (10 mm) O.D. tubing at 25-50 PSI (170-345 kPa), NSF-61 compliant.
- FAUCET HOT WATER: 3/8" (10 mm) O.D. tubing at 25-50 PSI (170-345 kPa), NSF-61 compliant.
- DRAIN: 2" (51 mm) IPS piped to open floor drain. No solid connection.
- STEAM TAKE-OFF CONNECTION: 3/4" (19 mm) IPS optional to operate adjacent equipment.
- SINK DRAIN: 1-1/8" (29 mm) O.D. tubing.

ELECTRICAL CHARACTERISTICS

MODEL	AVAILABLE kW	
	STANDARD	OPTIONAL
ECX-2S-6-6	42	48
ECX-10S-6-6		
ECX-2S-6-6		
ECX-10S-6-10		

kW	PHASE	AMPS PER LINE					
		208V	220V	240V	380V	415V	480V
42	3	116.6	110.2	101.0	63.8	58.4	50.5
48	3	N/A	N/A	115.5	72.9	66.8	57.7

SPECIFICATIONS

MODEL	A	SHIPPING WEIGHT	MIN. CLEARANCE	
ECX-2S-6-6	59.5 [1511]	910 lbs. [413 kg.]	SIDES	0
ECX-10S-6-6		950 lbs. [431 kg.]		
ECX-2S-6-10	72.5 [1842]	930 lbs. [422 kg.]	BACK	0
ECX-10S-6-10		970 lbs. [439kg.]		

WATER QUALITY STATEMENT

Water is the essential ingredient in steam equipment, water quality is the major factor affecting the performance of your appliance. Crown Steam Group offers a Comprehensive Water Treatment System which exceeds our minimum water requirements. Proof of installation and proper cartridges replacement is required for warranty coverage. Water supply to Crown Steam Group steamers must be within these guidelines.

Total dissolved solids.....	Less than 60 PPM	Chlorine	Less than 1.5 PPM
Total alkalinity	Less than 20 PPM	pH Factor	6.8 - 7.3
Silica.....	Less than 13 PPM		

Water which does not meet these standards should be treated with the installation of Middleby's Water Treatment System. Call 919-762-1000 if you have questions concerning your water meeting these parameters.

*Failure or malfunction of this appliance due to poor water quality is not covered under warranty.

Reference www.crownsteamgroup.com for complete warranty details and instructions.

DISCLAIMER

Terry System Cartridge Changes / Installation – "2-3 gallons of water MUST be purged at each cartridge change or new installation prior to water supply being fed to the steamer. Failure to do so can result in component damage within the steamer which is not covered under warranty. For additional guidance on proper installation, refer to install documentation provided with each Terry System and Replacement Cartridge Set."

**INTENDED FOR COMMERCIAL USE ONLY.
 NOT FOR HOUSEHOLD USE.**

