



ELECTRIC COUNTER STEAMER

Manual Fill, Manual Drain



EPXN-3



- EXPN-3
- EXPN-5

OPERATION SHALL BE BY:

Electrically heated, boiler free steam generation rated at:

- 9.0 kW for Model EPXN-3
- 15.0 kW for Model EPXN-5

The steam boiler shall be equipped for operation on:

- 208 VAC, 3 Phase, 50/60 Hz *
- 240 VAC, 3 Phase, 50/60 Hz *

*** UNIT SHALL BE FIELD CONVERTIBLE TO SINGLE PHASE AND ALSO CONFIGURABLE TO 2/3 RATING.**

- 6.0 kW for Model EPXN-3
- 10.0 kW for Model EPXN-5

STANDARD FEATURES:

- Energy Star Compliant
- 300 series stainless steel exterior
- 300 series stainless steel cooking chamber with coved corners
- Heavy gauge stainless steel door with full perimeter gasket
- Positive lock and seal mechanism with spring release door
- Illuminated timed/off/constant steam power switch
- Ready indicator light
- Cooking indicator light
- Add water indicator light with audible alarm
- 60 minute electromechanical timer with end of cycle audible alarm
- 4" adjustable legs
- Removable stainless steel pan supports
- Removable steam diffuser plate helps prevent objects from falling into water reservoir
- Selectable timed or constant steam cooking mode
- Electromechanical controls
- 16 oz. QuickClean treatment included

OPTIONS & ACCESSORIES AT ADDITIONAL COST

- | | | |
|---|---|---|
| <input type="checkbox"/> 220 VAC, 3 Phase, 50/60 Hz | <input type="checkbox"/> 380/220 VAC, 3 Phase, 50/60 Hz 4 wire | <input type="checkbox"/> 28" high single unit stand |
| <input type="checkbox"/> 380 VAC, 3 phase, 50/60 Hz | <input type="checkbox"/> 415/240 VAC, 3 Phase, 50/60 Hz 4 wire | <input type="checkbox"/> Double unit stacking stands available (see stacked spec sheet for details) |
| <input type="checkbox"/> 415 VAC, 3 phase, 50/60 Hz | <input type="checkbox"/> Correctional package | <input type="checkbox"/> Water Filter Treatment System |
| <input type="checkbox"/> 480 VAC, 3 phase, 50/60 Hz | <input type="checkbox"/> 120 minute timer | |
| <input type="checkbox"/> 600 VAC, 3 phase, 50/60 Hz (EPXN-3 only) | <input type="checkbox"/> Drain hose kit (includes 5' hose with fitting) | |

STANDARD CONSTRUCTION SPECIFICATIONS

Provide Crown model **EPXN-3 (3 pan) or EPXN-5 (5 pan)** countertop, boiler free convection steamer, c-CSA-us and NSF certified.

Unit shall be connectionless, no plumbing required.

Unit shall be constructed of satin finish 300 series stainless steel with a one piece welded 300 series stainless steel cooking chamber with coved corners.

The door shall have a removable inner liner of stainless steel with full perimeter gasket seal, an outer liner of one-piece all welded stainless steel, and a positive lock and seal mechanism with spring release.

The steamer shall have removable stainless steel pan supports and

steam diffuser plate.

The control housing shall be constructed of stainless steel with a full access removable panel.

The controls shall include an illuminated timed cooking/off/constant steam switch, a ready indicator light, cooking indicator light, 60 minute electric timer with audible alarm that signals the end of the cook cycle and a low water indicator light with audible alarm.

A door interlock switch shall interrupt steam generation when the door is open and shall be reactivated when the door is closed.

Provide options and accessories as indicated.



Approval Notes: _____

Models: EPXN-3 EPXN-5

EPXN

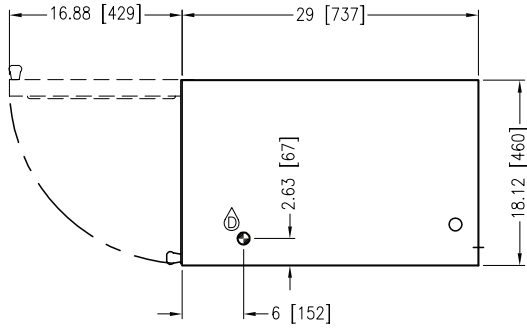

SERVICE CONNECTIONS
 ⚡ – ELECTRICAL CONNECTION: Ø 1 1/8" (29 mm) hole for electrical connection. Rating to be specified on data plate.
 ⚪ – DRAIN: 1/2" NPT

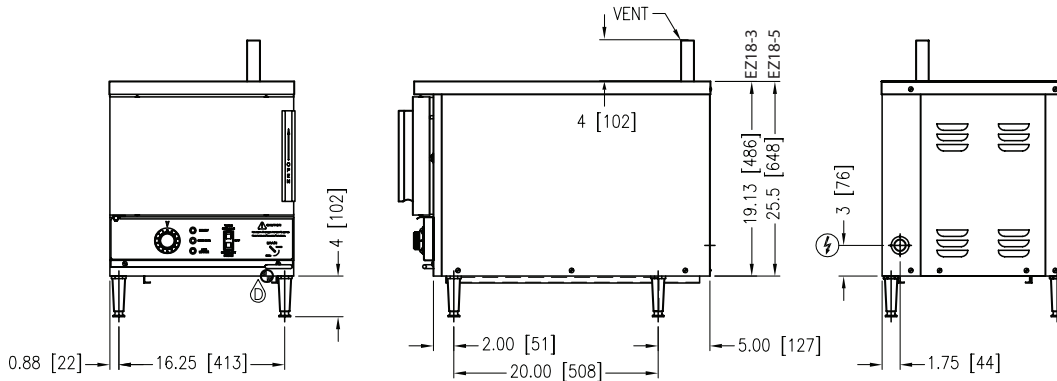

ELECTRICAL CHARACTERISTICS

MODEL	kW	AMPS/PHASE									
		208V		220V		240V		380V	415V	480 V	600V
		1 PH	3 PH	1 PH	3 PH	1 PH	3 PH	3 PH	3 PH	3 PH	3 PH
EPXN-3	9	43.3	25.0	40.9	23.6	37.5	21.7	13.7	12.5	10.8	8.7
	6	28.9	N/A	27.3	N/A	25.0	N/A	N/A	N/A	N/A	N/A
EPXN-5	15	72.1	41.6	68.2	39.4	62.5	36.0	22.8	20.9	18.0	14.4
	10	48.1	N/A	45.5	N/A	41.7	N/A	N/A	N/A	N/A	N/A

COMPARTMENT PAN CAPACITY, WEIGHT AND CLEARANCE

MODEL	PAN DEPTH	INCHES MM	1"	2.5"	4"	6"	SHIPPING WEIGHT	MINIMUM CLEARANCE	
			25	64	102	152			
EPXN-3	Total Quantity of Pans		6	3	2	1	161 lbs. [73 kg]	SIDES	0
EPXN-5			10	5	3	2			

WATER QUALITY STATEMENT

Water is the essential ingredient in steam equipment, water quality is the major factor affecting the performance of your appliance. Crown Steam Group offers a Comprehensive Water Treatment System as an option (at additional cost) which exceeds our minimum water requirements. Proof of installation and proper cartridges replacement is required for warranty coverage. Water supply to Crown Steam Group steamers must be within these guidelines.

Total dissolved solids.....Less than 60 PPM ChlorineLess than 1.5 PPM
 Total alkalinity Less than 20 PPM pH Factor6.8 - 7.3
 Silica.....Less than 13 PPM

Water which does not meet these standards should be treated with the installation of Middleby's Water Treatment System. Call 919-762-1000 if you have questions concerning your water meeting these parameters.

*Failure or malfunction of this appliance due to poor water quality is not covered under warranty.
Reference www.crownsteamgroup.com for complete warranty details and instructions.

DISCLAIMER

Terry System Cartridge Changes / Installation – "2-3 gallons of water MUST be purged at each cartridge change or new installation prior to water supply being fed to the steamer. Failure to do so can result in component damage within the steamer which is not covered under warranty. For additional guidance on proper installation, refer to install documentation provided with each Terry System and Replacement Cartridge Set."

**INTENDED FOR COMMERCIAL USE ONLY.
 NOT FOR HOUSEHOLD USE.**

