



UNDERCOUNTER
NUGGET
ICE MACHINE

IU-0345-AN

AIR-COOLED

Serve craveable nugget ice without giving up valuable floor space. Designed to fit neatly under counters, this compact unit produces up to **350 lbs. of ice per day** and holds **100 lbs.** in reserve—ideal for busy bars, cafés, and beverage programs. The soft, **chewable nugget ice** chills quickly to maximize flavor and drink enjoyment, while **LED bin illumination** improves visibility and speeds up scooping during peak hours.

KEY FEATURES:

- High daily nugget ice production: ~340 lb/day (90F/70F)
- Large built-in storage capacity: ~100 gallons
- Undercounter footprint (nominal): ~24" W x 26" D x 39" H
- Standard electrical: 115V / 60Hz / 1-phase
- Low operating amperage: ~9A
- Energy performance reference: ~6.5 kWh/100 lb @ 90/70
- Natural refrigerant: R290A
- Durable exterior materials: stainless steel front/side/top
- Galvanized rear panel
- Water connection size: 3/8" supply
- Drain connection size: 3/4" drain
- Standard IU control panel + USB port (FND)
- Bin features: batwing-style ice deflector; thermostat bin sensor
- Adjustable steel feet/legs: ~1" adjustability
- Unique "batwing" shaped dispenser chute inside unit ensures even nugget distribution

STANDARD WARRANTY:

- Ice Maker: 3-Year Parts & Labor
- Compressor: 5-Year Parts & 3-Year Labor

CERTIFICATIONS



PLAN VIEW

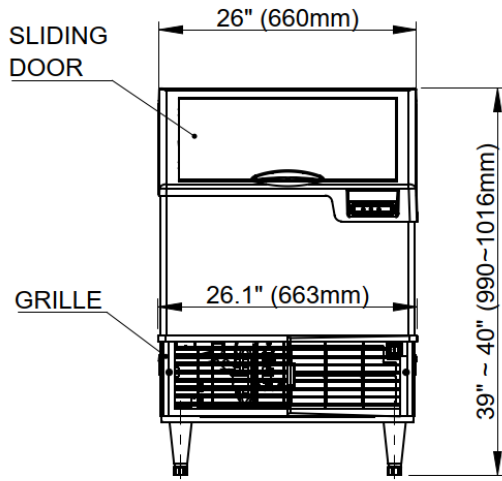

FRONT VIEW

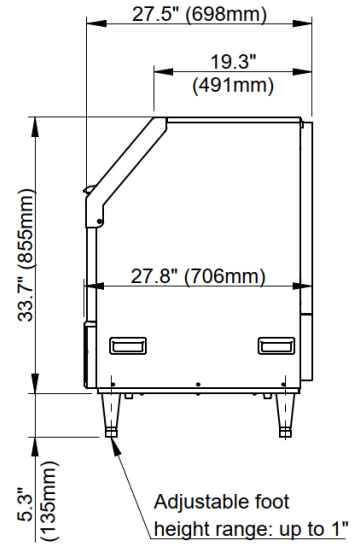

SIDE VIEW

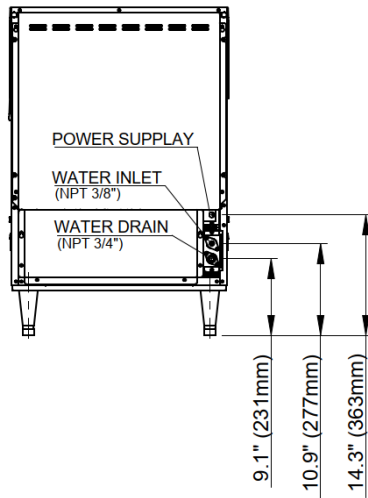

BACK VIEW

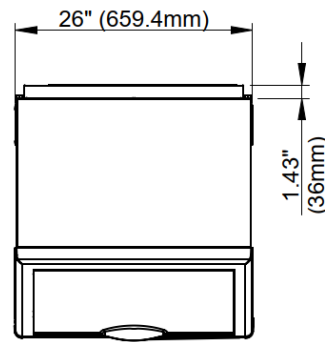

TOP VIEW