



GAS COMPARTMENT STEAMER WITH KETTLE AND GAS FIRED STEAM BOILER



GCX-2S-10

- GCX-2S-6 GCX-2S-10
- GCX-10S-6 GCX-10S-10

OPERATION SHALL BE BY:

Gas heated steam boiler operating at 9 -11 psi (62 - 76 kPa).

The controls shall be equipped for operation on 115 VAC, single phase 50/60 Hz.

- Natural Gas
- LP Gas

Standard Features

- Water Treatment System
- Split water line
- CSD-1 boiler controls
- Electronic ignition
- Automatic blowdown
- Drain tempering system for 140 degree temperature requirement (requires 1/2" cold water connection)

MODEL	DESCRIPTION	PAN CAPACITY PER COMPARTMENT			
		PAN DEPTH			
		1"	2-1/2"	4"	6"
GCX-2S-6	6 pan steamer with 6 gallon kettle and 250,000 BTU boiler.	6	3	2	1
GCX-2S-10	6 pan steamer with 10 gallon kettle and 250,000 BTU boiler.				
GCX-10S-6	10 pan steamer with 6 gallon kettle and 250,000 BTU boiler.	10	5	3	2
GCX-10S-10	10 pan steamer with 10 gallon kettle and 250,000 BTU boiler.				

OPTIONS & ACCESSORIES

- Floor Protective Panel for 36" Gas Boiler Based Cabinets and Up (aluminum panel, painted on top with special anti-reflective black paint) (8976-1)
- Floor Protective Panel 24" Gas Boiler Based Cabinets (aluminum panel, painted on top with special anti-reflective black paint) (8978-1)
- 300,000 BTU
- 220-240 VAC operation (specify voltage)(GBVS-1)
- Stainless steel rear panel (SSB-)
- Stainless steel frame (SSF-)
- Correctional package
- Load compensating timers (LCT-)
- Spray and rinse assembly
- Steam take-off kit (STOK)
- Water in "Y" strainer (condenser feed)
- Pour lip strainer (TKS-)
- One piece stainless steel lift off cover (C-)
- Lift-out stainless steel basket strainer (SSB-)

STANDARD CONSTRUCTION SPECIFICATIONS

Shall be a Southbend Steam model GCX-2S-6, GCX-2S-10, GCX-10S-6 or GCX-10S-10, convection steamer complete with 6 or 10 Gallon Kettle on a modular gas fired steam boiler base, with stainless steel type 304 exterior and #4 finish, deck mounted faucet valve, swing nozzle and integral sink with common drain.

The convection steamer shall have doors with a removable inner liner of stainless steel, full perimeter gasket seal, outer shell of one piece, all welded, stainless steel, positive lock and seal mechanism and a stainless steel drip trough connected to the drain in order to collect condensate when doors are opened.

Each cooking chamber shall be constructed of all welded type 316 stainless steel, fully insulated and provided with removable stainless steel pan supports and shall be:

- GCX-2S: 13.875"W x 10.875"H x 19.875"D (352 mm x 276 mm x 504 mm).
- GCX-10S: 13.875"W x 17.375"H x 19.875"D (352 mm x 441 mm x 504 mm).

Steamer controls shall be accessible through a fully removable side panel and each compartment shall include a 60 minute mechanical timer with ready and cooking pilot light and shall interrupt steam flow to the chamber when the compartment door

is opened during cooking cycle and shall be reactivated when the door is closed.

An audible signal will sound at the end of the cooking cycle.

The cabinet base with gas boiler and controls shall be provided with full perimeter painted angle frame, reinforced kettle and boiler mountings, hinged doors with magnetic latch and 6" (152 mm) stainless steel legs fitted 4 adjustable flanged feet on the front for securing unit to the floor.

Boiler controls shall include automatic water level control, pressure gauge, water gauge glass, operating pressure control, safety high-limit pressure control, and safety relief valve.

The boiler shall be ASME code stamped and National Board registered.

Unit comes standard with a water treatment system, split water line, CSD-1 boiler controls, electronic ignition, and automatic blowdown.

SEE REVERSE SIDE OF SPEC SHEET FOR WATER TREATMENT SYSTEM STATEMENTS



Approval Notes: _____

GCX-2S-6

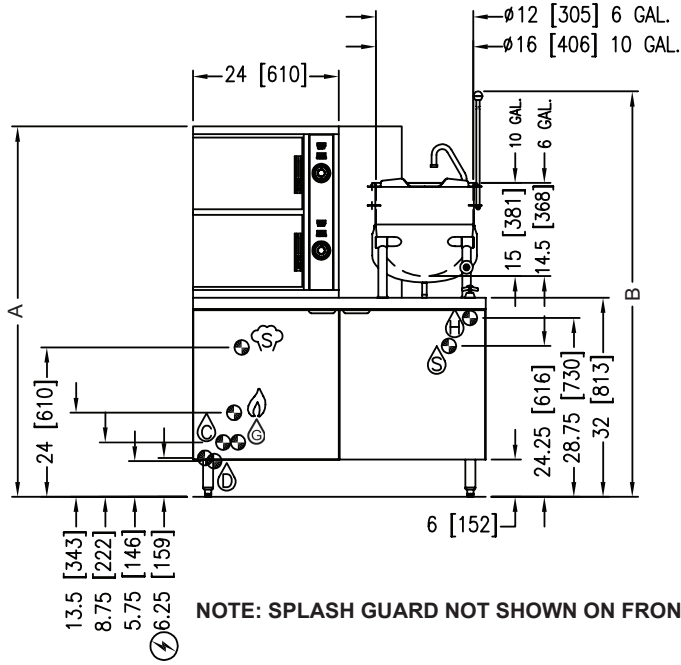

NOTE: SPLASH GUARD NOT SHOWN ON FRONT VIEW.

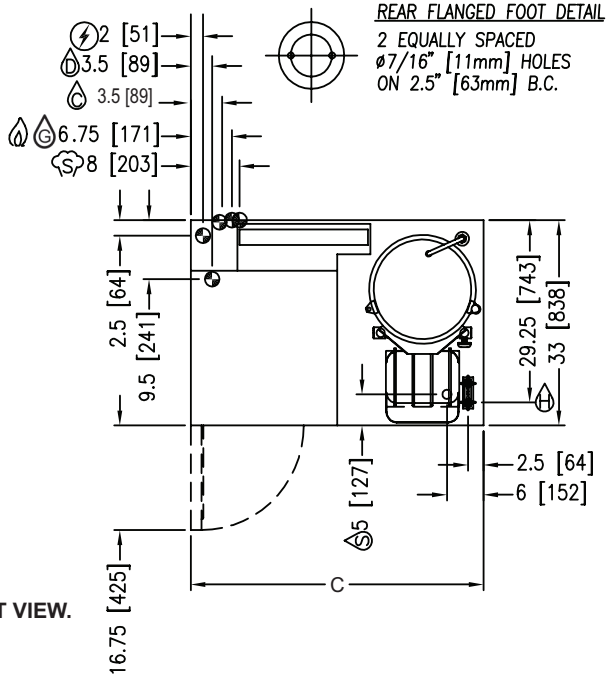

SERVICE CONNECTIONS

- ELECTRICAL CONNECTION: 1/2" (13 mm) conduit connection to controls. 120 VAC-60Hz-1PH. 2 Amps per compartment or as specified on data plate.
- BOILER FEED WATER: 1/2" (13 mm) NPT at 25-50 PSI (170-345 kPa).
- CONDENSATE COLD WATER: 1/2" (13 mm) NPT at 25-50 PSI (170-345 kPa) (OPTIONAL)
- GAS CONNECTION: 3/4" (19 mm) IPS supply line required.
- STEAM TAKE-OFF CONNECTION: 3/4" (19 mm) IPS optional to operate adjacent equipment.
- HOT WATER: 3/8" (10 mm) O.D. tubing at 25-50 PSI (170-345 kPa).
- DRAIN: 2" (51 mm) IPS piped to open floor drain. No solid connection.
- SINK DRAIN: 1 1/8" (29 mm) O.D. tubing.

GAS SUPPLY AND SPECIFICATIONS

BTU/HOUR	KW/HOUR	WATER COLUMN PRESSURE		MODEL	SHIPPING WEIGHT	A	B	C
		NATURAL	PROPANE					
250,000	73.3	7" - 14" [178 mm - 355 mm]	11" - 14"	GCX-2S-6	980 lbs. [445 kg.]	59.5 [1511]	66.13 [1680]	44 [1118]
			11" - 14"					
300,000	87.9	[178 mm - 355 mm]	11" - 14"	GCX-10S-6	1000 lbs. [454 kg.]	72.5 [1842]	65.13 [1654]	48 [1219]
			11" - 14"	GCX-2S-10	1030 lbs. [467 kg.]	59.5 [1511]		
				GCX-10S-10	1020 lbs. [462 kg.]	72.5 [1842]		

WATER QUALITY STATEMENT

Water is the essential ingredient in steam equipment, water quality is the major factor affecting the performance of your appliance. Crown Steam Group offers a Comprehensive Water Treatment System which exceeds our minimum water requirements. Proof of installation and proper cartridges replacement is required for warranty coverage. Water supply to Crown Steam Group steamers must be within these guidelines.

Total dissolved solids.....Less than 60 PPM	ChlorineLess than 1.5 PPM
Total alkalinity Less than 20 PPM	pH Factor6.8 - 7.3
Silica.....Less than 13 PPM	

Water which does not meet these standards should be treated with the installation of Middleby's Water Treatment System. Call 919-762-1000 if you have questions concerning your water meeting these parameters.

*Failure or malfunction of this appliance due to poor water quality is not covered under warranty.
Reference www.crownsteamgroup.com for complete warranty details and instructions.

DISCLAIMER

If installing on any floor with an epoxy coating or other combustible floor surface (i.e., a surface other than quarry tile, cement or natural stone), contact the factory for installation options as damage due to improper installation is not covered under warranty.

Terry System Cartridge Changes / Installation – "2-3 gallons of water MUST be purged at each cartridge change or new installation prior to water supply being fed to the steamer. Failure to do so can result in component damage within the steamer which is not covered under warranty. For additional guidance on proper installation, refer to install documentation provided with each Terry System and Replacement Cartridge Set."

**INTENDED FOR COMMERCIAL USE ONLY.
 NOT FOR HOUSEHOLD USE.**

