



Project Name: _____ AIA#: _____

Model #: _____ Location: _____

SIS#: _____ Item #: _____ Quantity: _____

SG213A Premium Advanced Automatic Slicer

**Precision Cutting
Powerful Performance
Easy Cleaning**

The heavy-duty S2-Series of premium slicers from Globe deliver powerful performance in a compact, intuitive design with improved cleanability and Globe-trusted durability.



SG213A

Removable knife makes cleanup easier while providing more operator protection



Model: SG213A (*Advanced Automatic*)

Standard Features:

Cutting System

- 13" carbon steel knife with hardened edge provides quality slices and higher yields
- Top mounted knife sharpening system utilizes long-lasting synthetic diamond wheels for quick and easy sharpening

Drive System

- Variable speed, brushless motor delivers 3ft/lbs of peak torque
- Patented, auto engagement system ensures no slippage when slicing in automatic mode

Interlocks

- No-Volt Release: prevents inadvertent reactivation of knife in the event of power interruption
- Carriage Interlock: prevents the knife from running when the carriage is not secured
- Home To Start: ensures the carriage is in the home position in order for the unit to start
- Close To Stop: powers the unit down after the slicer gauge plate is closed
- Knife Time Out: automatically shuts off the motor if the carriage remains idle for 30 seconds (*time can be adjusted to as little as 5 seconds or turned off completely*)

Product Handling

- Large-capacity carriage accommodates prosciutto, mortadella, and bacon
- Patented meat grip design for superior product hold
- 50° gravity-feed carriage design guides product toward the blade for effortless slicing

Cleanability

- Patented, anodized aluminum design and construction for quick and easy cleaning
- Patented, removable meat grip design allows for easy handling and is dishwasher safe
- Removable upper carriage with lock-and-slide design allows for easy reassembly and unobstructed cleaning access
- Removable knife sharpener for quick and easy cleaning
- Integrated lift lever allows easy access for fast, efficient cleaning

Structure & Controls

- Cam driven indexing system enables accurate and precise slice thickness adjustment up to 5/8" (0.625"), with optimum control on the thinnest cuts
- Control panel features tactile Start, Stop, Speed, and Stroke buttons as well as power and run indicator lights

Interface & Diagnostics

- Patented, graphic user interface with Clear-Text LCD display provides built-in site diagnostics and system counters
- Patent-pending, 4-hour cleaning notification keeps operators on schedule for regular cleaning and sanitation
- Multi-language interface (English, French, Spanish)
- Three selectable cut lengths and four selectable slicing speeds ensure repeatable slice accuracy

Warranty

- Two year parts and labor



Approved by: _____ Date: _____



SG213A Premium Advanced Automatic Slicer Factory Installed Options



Removable Knife Package (KNIFE-RMV)

- Knife is secured in tool for operator protection
- Tool easily removes knife for more access under the knife and faster, easier cleanup
- Knife and removal tool are dishwasher safe

Stainless Steel Blade (SSK)

- Ideal for highly acidic applications commonly found in preparation of onions and citrus fruits
- Resists enzyme/protein exposure in raw red meat slicing to help prevent corrosion and extend blade life
- Offers better corrosion resistance caused by extreme moisture applications (meat rooms)



S2-Series Advanced Model Features

- Home To Start ensures the carriage is in the home position in order for the unit to start
- Patented 4-Hour Cleaning notification keeps operators on schedule for regular cleaning and sanitation
- Carriage Interlock prevents knife from running when the carriage is not secured
- Knife Time Out automatically shuts off the motor if the carriage remains idle for 30 seconds (*timer can be adjusted to as little as 5 seconds or turned off completely*)
- Close To Stop feature powers the unit down after the slicer gauge plate is closed





SG213A Premium Advanced Automatic Slicer Accessories



S2-FF125
Low Food Fence
(12.125" x 1.125")



S2-FF300
High Food Fence
(12.125" x 3.00")



S2-FPA
Food Prep Attachment
(14.00" x 7.76")



SC-LARGE
Slicer Sanitation Cover



S-XDSL M
Extended 3-Year Warranty

S2-Series Features, Options & Accessory Guide

FEATURE	S213	S213A	SG213	SG213A
Lock and Slide Removable Carriage	■	■	■	■
Removable Carriage Interlock			■	■
Home to Start (Carriage must be in Home position for blade to rotate)			■	■
Home Return				■
Time Out (Blade will stop running if not in use)*			■	■
Close to Stop (Blade will stop running when gauge plate is closed)			■	■
LCD Display		■	■	■
Site Diagnostics		■	■	■
System Counters		■	■	■
No Volt Release	■	■	■	■
Slicing Length Settings		2		3
Slicing Speed Settings		2		4
CORR - Correctional Package (Factory Option)**	■	■		
KNIFE-RMV - Removable Knife (Factory Option)			■	■
FROZEN - Frozen Package (Factory Option)***	■	■		
SSK - Stainless Steel Knife (Factory Option)****	■	■	■	■

*Time Out is programmable. Factory setting is 30 seconds.

**Correctional package has a fixed carriage

***Frozen package has a max slice thickness of 1/8"

****Made from SS430 stainless steel



SG213A Premium Advanced Automatic Slicer

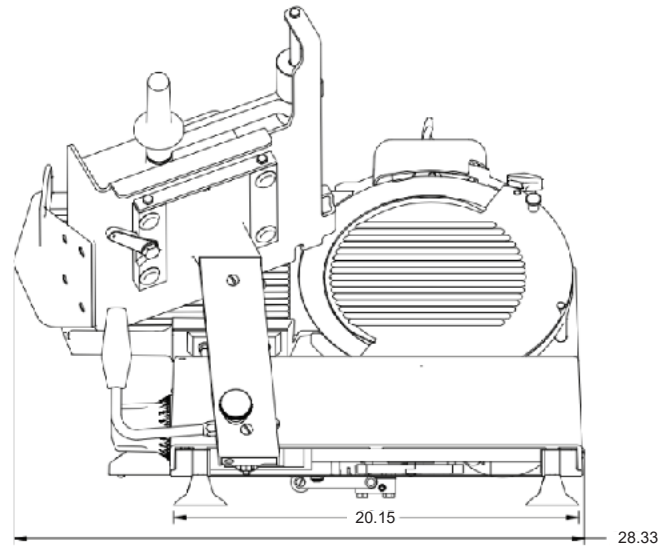
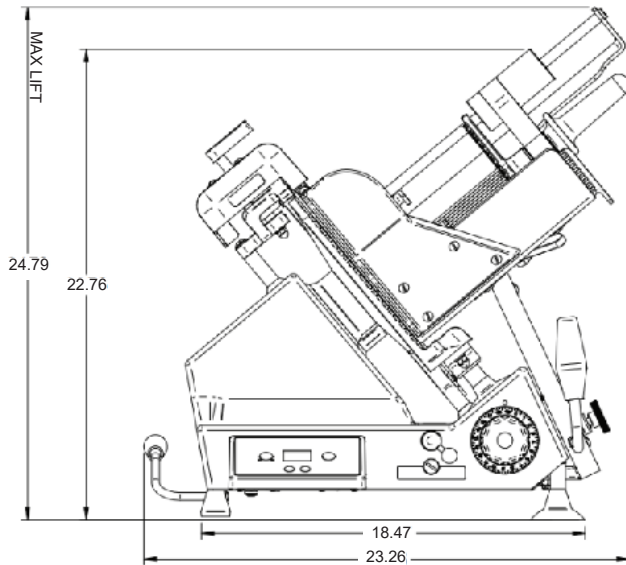

UNIT: Inches

Drawings available through KCL. www.kclcad.com

SPECIFICATIONS

Model	Motor	Volts	Amps	NEMA Plug Type	Drive Type	Slicing Vol. / Day	Cheese Slicing	Blade Diameter	Max Slice	Product Cutting Capacity		
										D (Diameter)	H (Height)	W (Width)
SG213A	1/2 HP	110-60-1	2	5-15	Poly-V Belt	All Day		13" (33.02 cm)	5/8" (1.59 cm)	7.5" (19.05 cm)	13.75" (35 cm)	11" (27.94 cm)

Cord & Plug: Attached 7 ft. flexible 3-wire cord with molded plug fits a grounded receptacle.

DIMENSIONS | SHIPPING INFORMATION

Reinforced carton for shipping. The weight and dimensions of this reinforced carton are included below and may vary from shipment to shipment.

Shipped on a pallet. Freight class 85.

Model	Max Overall Dimensions	Net Weight	Shipping Dimensions	Shipping Weight
SG213A	23.9" W x 28.3" D x 25.4" H (60.7 cm x 71.9 cm x 64.5 cm)	91 lbs. (41.27 kg)	32" W x 31.5" D x 31.5" H (81.3 cm x 80 cm x 80 cm)	131 lbs. (59.42 kg)

FACTORY INSTALLED OPTIONS:

- KNIFE-RMV - Removable knife includes removal tool
- SSK - Stainless steel knife in lieu of Carbon Steel

OPTIONAL ACCESSORIES:

- S2-FF125 - Food Fence Low, 1.25"
- S2-FF300 - Food Fence High, 3.00"
- S2-FPA - Food Prep Attachment
- SC-LARGE - Sanitation Cover
- S-XDSLML - Extended 3-Year Warranty

Constructed of durable anodized aluminum for quick, easy cleaning and long service life, the SG213A features a 13" carbon steel knife with a hardened edge for consistent slice quality and higher yields. A top-mounted knife sharpening system uses long-lasting synthetic diamond wheels for quick, easy sharpening, and the sharpener is removable for simplified cleaning. Precise slicing is supported by a reverse-action, cam-driven indexing system providing accurate thickness adjustment up to 5/8" (0.625") with excellent control on the thinnest cuts. The large-capacity, 50° gravity-feed carriage is designed to handle products such as prosciutto, mortadella, and bacon, and a patented meat grip provides superior product hold. The SG213A is powered by a variable-speed, brushless motor delivering 3 ft/lbs of peak torque, paired with a patented auto-engagement drive system to eliminate slippage in automatic mode. Supported by multiple interlocks including No-Volt Release to prevent inadvertent restart after power interruption, Carriage Interlock to prevent operation when the carriage is not secured, Home to Start to ensure the carriage is in position prior to start-up, Close to Stop to power down when the gauge plate is closed, and a Knife Time Out function that shuts off the motor after 30 seconds of idle time (adjustable down to 5 seconds or can be disabled). Cleanability is enhanced with a removable, dishwasher-safe meat grip, a removable upper carriage with lock-and-slide design for unobstructed access, an integrated lift lever for easier access, and the removable sharpener. Controls include tactile Start, Stop, Speed, and Stroke buttons with power and run indicator lights. A patented graphic user interface with Clear-Text LCD display provides built-in site diagnostics and system counters, along with a patent-pending 4-hour cleaning notification to help keep sanitation on schedule; the interface supports English, French, and Spanish. Three selectable cut lengths and four selectable slicing speeds ensure repeatable slice accuracy. ETL listed. Backed by a two-year parts and labor warranty.