



Project Name: \_\_\_\_\_ AIA#: \_\_\_\_\_

Model #: \_\_\_\_\_ Location: \_\_\_\_\_

SIS#: \_\_\_\_\_ Item #: \_\_\_\_\_ Quantity: \_\_\_\_\_

# SG213 Premium Advanced Manual Slicer

**Precision Cutting  
Powerful Performance  
Easy Cleaning**

*The heavy-duty S2-Series of premium slicers from Globe deliver powerful performance in a compact, intuitive design with improved cleanability and Globe-trusted durability.*



SG213

Removable knife makes cleanup easier while providing more operator protection



**Model:** SG213 (*Advanced Manual*)

**Standard Features:**

**Cutting System**

- 13" carbon steel knife with hardened edge provides quality slices and higher yields
- Top mounted knife sharpening system utilizes long-lasting synthetic diamond wheels for quick and easy sharpening

**Interlocks**

- No-Volt Release: prevents inadvertent reactivation of knife in the event of power interruption
- Carriage Interlock: prevents the knife from running when the carriage is not secured
- Home To Start: ensures the carriage is in the home position in order for the unit to start
- Close To Stop: powers the unit down after the slicer gauge plate is closed
- Knife Time Out: automatically shuts off the motor if the carriage remains idle for 30 seconds (*time can be adjusted to as little as 5 seconds or turned off completely*)

**Product Handling**

- Large-capacity carriage accommodates prosciutto, mortadella, and bacon
- Patented meat grip design for superior product hold
- 50° gravity-feed carriage design guides product toward the blade for effortless slicing

**Cleanability**

- Patented, anodized aluminum design and construction for quick and easy cleaning
- Patented, removable meat grip design allows for easy handling and is dishwasher safe
- Removable upper carriage with lock-and-slide design allows for easy reassembly and unobstructed cleaning
- Removable knife sharpener for quick and easy cleaning
- Integrated lift lever allows easy access for fast, efficient cleaning

**Structure & Controls**

- Reverse-action cam driven indexing system enables accurate and precise slice thickness adjustment up to 5/8" (0.625"), with optimum control on the thinnest cuts
- Control panel features tactile Start and Stop buttons as well as power and run indicator lights

**Interface & Diagnostics**

- Patented, graphic user interface with Clear-Text LCD display provides built-in site diagnostics and system counters
- Patent-pending, 4-hour cleaning notification keeps operators on schedule for regular cleaning and sanitation
- Multi-language interface (English, French, Spanish)

**Warranty**

- Two year parts and labor



Approved by: \_\_\_\_\_ Date: \_\_\_\_\_



## SG213 Premium Advanced Manual Slicer Factory Installed Options



### Removable Knife Package (KNIFE-RMV)

- Knife is secured in tool for operator protection
- Tool easily removes knife for more access under the knife and faster, easier cleanup
- Knife and removal tool are dishwasher safe

### Stainless Steel Blade (SSK)

- Ideal for highly acidic applications commonly found in preparation of onions and citrus fruits
- Resists enzyme/protein exposure in raw red meat slicing to help prevent corrosion and extend blade life
- Offers better corrosion resistance caused by extreme moisture applications (meat rooms)



## S2-Series Advanced Model Features

- Home To Start ensures the carriage is in the home position in order for the unit to start
- Patented 4-Hour Cleaning notification keeps operators on schedule for regular cleaning and sanitation
- Carriage Interlock prevents knife from running when the carriage is not secured
- Knife Time Out automatically shuts off the motor if the carriage remains idle for 30 seconds (*timer can be adjusted to as little as 5 seconds or turned off completely*)
- Close To Stop feature powers the unit down after the slicer gauge plate is closed





# SG213 Premium Advanced Manual Slicer Accessories



**S2-FF125**  
Low Food Fence  
(12.125" x 1.125")



**S2-FF300**  
High Food Fence  
(12.125" x 3.00")



**S2-FPA**  
Food Prep Attachment  
(14.00" x 7.76")



**SC-LARGE**  
Slicer Sanitation Cover



**S-XDSLIM**  
Extended 3-Year Warranty

## S2-Series Features, Options & Accessory Guide

FEATURE	S213	S213A	SG213	SG213A
Lock and Slide Removable Carriage	■	■	■	■
Removable Carriage Interlock			■	■
Home to Start (Carriage must be in Home position for blade to rotate)			■	■
Home Return				■
Time Out (Blade will stop running if not in use)*			■	■
Close to Stop (Blade will stop running when gauge plate is closed)			■	■
LCD Display		■	■	■
Site Diagnostics		■	■	■
System Counters		■	■	■
No Volt Release	■	■	■	■
Slicing Length Settings		2		3
Slicing Speed Settings		2		4
<b>CORR</b> - Correctional Package (Factory Option)**	■	■		
<b>KNIFE-RMV</b> - Removable Knife (Factory Option)			■	■
<b>FROZEN</b> - Frozen Package (Factory Option)***	■	■		
<b>SSK</b> - Stainless Steel Knife (Factory Option)****	■	■	■	■

\*Time Out is programmable. Factory setting is 30 seconds.

\*\*Correctional package has a fixed carriage

\*\*\*Frozen package has a max slice thickness of 1/8"

\*\*\*\*Made from SS430 stainless steel



# SG213 Premium Advanced Manual Slicer

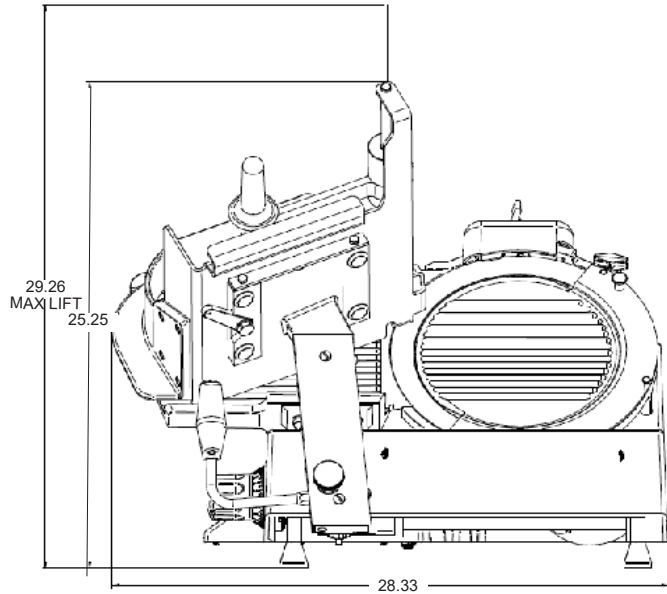
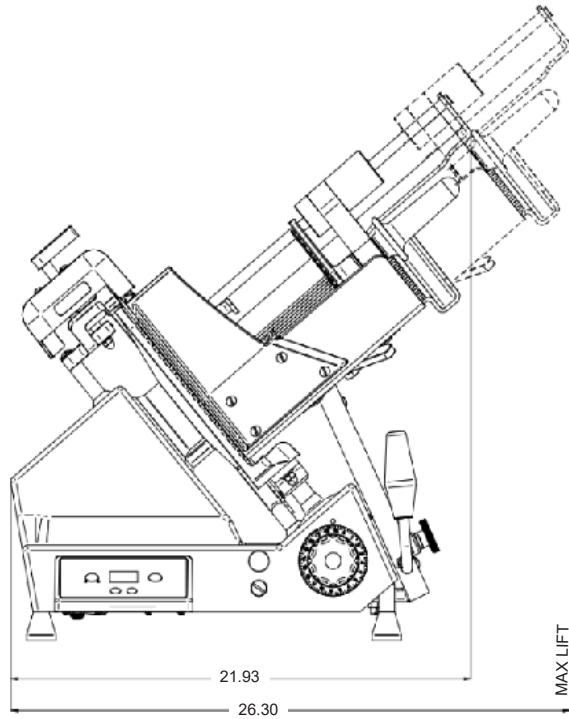

UNIT: Inches

Drawings available through KCL. [www.kclcad.com](http://www.kclcad.com)

## SPECIFICATIONS

Model	Motor	Volts	Amps	NEMA Plug Type	Drive Type	Slicing Vol. / Day	Cheese Slicing	Blade Diameter	Max Slice	Product Cutting Capacity		
										D (Diameter)	H (Height)	W (Width)
SG213	1/2 HP	110-60-1	2	5-15	Poly-V Belt	All Day	0% to 100%	13" (33.02 cm)	5/8" (1.8588 cm)	7.5" (19.05 cm)	13.75" (35 cm)	11" (27.94 cm)

Cord & Plug: Attached 7 ft. flexible 3-wire cord with molded plug fits a grounded receptacle.

## DIMENSIONS | SHIPPING INFORMATION

Reinforced carton for shipping. The weight and dimensions of this reinforced carton are included below and may vary from shipment to shipment.

**Shipped on a pallet. Freight class 85.**

Model	Max Overall Dimensions	Net Weight	Shipping Dimensions	Shipping Weight
SG213	22" W x 28.3" D x 24.8" H (55.9 cm x 71.9 cm x 63 cm)	89 lbs. (40.37 kg)	32" W x 31.5" D x 31.5" H (81.3 cm x 80 cm x 80 cm)	129 lbs. (58.51 kg)

### FACTORY INSTALLED OPTIONS:

- KNIFE-RMV - Removable knife includes removal tool
- SSK - Stainless steel knife in lieu of Carbon Steel

### OPTIONAL ACCESSORIES:

- S2-FF125 - Food Fence Low, 1.25"
- S2-FF300 - Food Fence High, 3.00"
- S2-FPA - Food Prep Attachment
- SC-LARGE - Sanitation Cover
- S-XDSL M - Extended 3-Year Warranty

Constructed of durable anodized aluminum for quick, easy cleaning and long service life, the SG213 features a 13" carbon steel knife with a hardened edge for consistent slice quality and higher yields. A top-mounted knife sharpening system uses long-lasting synthetic diamond wheels for quick, easy sharpening, and the sharpener is removable for simplified cleaning. Precise slicing is supported by a reverse-action, cam-driven indexing system providing accurate thickness adjustment up to 5/8" (0.625") with excellent control on the thinnest cuts. Product handling is optimized with a large-capacity 50° gravity-feed carriage designed to accommodate items such as prosciutto, mortadella, and bacon, along with a patented meat grip for superior product hold. Supported by multiple interlocks including No-Volt Release, Carriage Interlock, Home to Start, Close to Stop, and a Knife Time Out feature that automatically shuts off the motor after 30 seconds of inactivity (adjustable down to 5 seconds or can be disabled). Cleanability is enhanced with a removable, dishwasher-safe meat grip, a removable upper carriage with lock-and-slide design for unobstructed access, an integrated lift lever for easier access, and the removable sharpener. The control panel includes tactile Start/Stop buttons plus power and run indicator lights, while the patented graphic user interface with Clear-Text LCD display provides built-in site diagnostics, system counters, and a multi-language interface (English, French, Spanish). A patent-pending 4-hour cleaning notification helps keep operators on schedule for regular sanitation. ETL listed. Backed by a two-year parts and labor warranty.