

Project Name: _____ AIA#: _____

Model #: _____ Location: _____

SIS#: _____ Item #: _____ Quantity: _____



25 Quart Planetary Bench Mixer

*The Perfect Mix of Value,
Performance & Durability*

*Features front mounted touch pad control
panel with 60-minute digital timer!*



Model

SPC25

Standard Features

- Powerful 3/4 HP custom built motor
- Gear-driven, high-torque transmission
- Heat-treated hardened steel alloy gears & shafts
- Three fixed speeds
- Permanently lubricated transmission
- Thermal overload protection
- Front-mounted touch pad controls with 60-minute digital timer and last-batch recall
- Removable stainless steel, interlocking bowl guard with built-in fully welded ingredient chute
- Interlocked bowl lift
- Motor break quickly stops rotation of the agitator
- Rigid cast iron body
- Industry standard #12 attachment hub
- NSF approved enamel gray paint
- 6-foot cord and ground plug

Standard Accessories/Attachments

- 25-qt. stainless steel bowl (#304 series)
- Aluminum flat beater
- Stainless steel wire whip
- Aluminum spiral dough hook
- Non-slip rubber feet

Warranty

- *Two years parts and labor*

Optional Accessories

- Seismic flange kit
- Polycarbonate splash shield insert
- Slicer/shredder/grater for #12 hub
- Meat grinder for #12 hub
- Meat tenderizer for #12 hub
- Strip cutter for #12 hub
- Stainless steel flat beater
- Stainless steel spiral dough hook
- 10-qt. adapter kit
- Mixer table with undershelf

To select options, see complete list on back

Approved by: _____ Date: _____

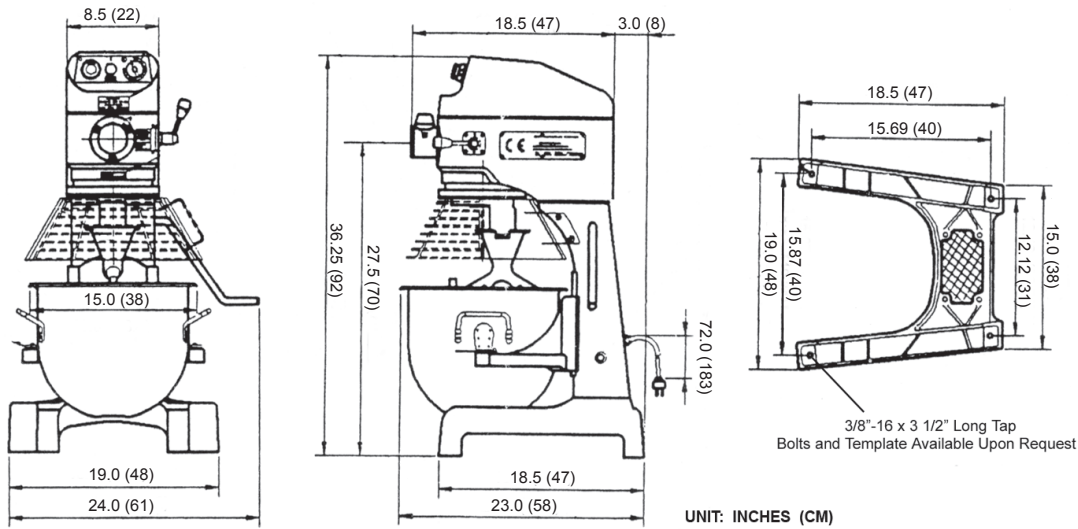

Drawings available through KCL at www.kclcad.com.

SPECIFICATIONS

Model	Motor	Volts	Amps	Transmission Type	Capacity	Controls	Agitator Speeds (RPMs)			Attachment Speeds (RPMs)		
							1st	2nd	3rd	1st	2nd	3rd
SPC25	3/4 HP	115/60/1	11	Gear	25 qt 24 liter	Front-mounted digital controls & timer	101	185	355	57	105	202

Cord & Plug: Attached 6-foot flexible 3-wire cord with molded plug fits a grounded receptacle. NEMA 5-15P (⚠)

DIMENSIONS | SHIPPING INFORMATION

Cartons are reinforced for shipping. The weight and dimensions of this reinforced carton are included below and may vary from shipment to shipment. **This product ships on a pallet. Freight class 85.**

Model	Base Foot Print	Overall Dimensions	Net Weight	Shipping Dimensions	Shipping Weight
SPC25	19" W x 18.45" D (48 cm x 47 cm)	24" W x 23" D x 36.25" hH (61 cm x 58 cm x 92 cm)	264 lbs (120 kg)	32" W x 40" D x 49" H (81 cm x 102 cm x 125 cm)	325 lbs (147 kg)

Mixer is constructed of a rigid cast iron body with front-mounted controls and a digital 60-minute timer with last-batch recall. Mixer has a 3/4 HP custom built motor with overload protection and gear-driven, high torque permanently lubricated transmission consisting of heat-treated hardened steel alloy gears and shafts. Mixer comes with 25 qt. stainless steel bowl, aluminum flat beater, stainless steel wire whip, and aluminum dough hook and non-slip rubber feet. Interlocked, removable stainless steel bowl guard with fully welded on ingredient chute. Mixer has #12 attachment hub and interlocked bowl lift. Mixer is NSF and ETL listed. Two-year parts and labor warranty.

OPTIONAL MIXER ACCESSORIES AND HUB ATTACHMENTS

MIXER:

- XXSEISMIC KIT-SM** Seismic kit
- XXBGSHIELD-25** Bowl guard shield
- XXBOWL-25** 25 qt stainless steel (S/S) bowl
- XXBEAT-25** Alum. flat beater
- XXBEAT-25SS** S/S flat beater
- XXHOOK-25** Aluminum dough hook
- XXHOOK-25SS** S/S dough hook
- XXWHIP-25** S/S wire whip
- XXHDWHIP25-4** Heavy-duty 4 mm S/S wire whip
- XXACC10-25** Adapter kit - 10 qt bowl, hook, beater and whip
- XTable** S/S countertop mixer table with under shelf (30" W x 24" D x 24" H)

- XXSCR-25** Bowl scraper (incl. mounting kit)
- HUB:**
- XVSGH 9"** Slicer/Shredder/Grater housing only (no plates included-must select from plates listed on this sheet)
- XASP** Adjustable slicing plate (for vegetables only)
- XPH** Plate holder - *only 1 required
- Shredding Plates:**
- XSP332*** 3/32" (2.3 mm)
- XSP316*** 3/16" (4.7 mm)
- XSP14*** 1/4" (6.3 mm)
- XSP516*** 5/16" (7.9 mm)
- XSP12*** 1/2" (12.7 mm)

- XGP*** Grating plate
- XMCA-SS** Meat grinder assembly (Polished stainless steel cylinder, worm gear, ring, and s/s pan. Includes knife, 3/16" plate, and pusher.)
- XXCK** Chopper knife for XMCA-SS
- L00670** Meat Tenderizer attachment
- L00783** Strip Cutter attachment

Chopper Plate Sizes Available:

- CP02-12** 1/16" (2 mm)
- CP04-12** 5/32" (4 mm)
- CP05-12** 3/16" (5 mm)
- CP06-12** 1/4" (6 mm)
- CP08-12** 5/16" (8 mm)
- CP10-12** 3/8" (10 mm)

- CP12-12** 1/2" (12 mm)
- CP14-12** 9/16" (14 mm)
- CP16-12** 5/8" (16 mm)
- CP18-12** 11/16" (18 mm)
- CP00-12** Stuffing plate
- XST12** 1/2" Stuffing tube (mutton)
- XST34** 3/4" Stuffing tube (pork)

- FACTORY INSTALLED OPTION:**
- XXCORR-25** Correctional package, includes tamper resistant external fasteners.