

Project Name: \_\_\_\_\_ AIA#: \_\_\_\_\_

Model #: \_\_\_\_\_ Location: \_\_\_\_\_

SIS#: \_\_\_\_\_ Item #: \_\_\_\_\_ Quantity: \_\_\_\_\_



# 40 Quart Planetary Floor Mixer

*The Perfect Mix of Value,  
Performance & Durability*

*Features front mounted touch pad control  
panel with 60-minute digital timer!*



AutoQuotes

## Model

SPC40

## Standard Features

- Powerful custom built 2 HP motor
- Gear-driven, high-torque transmission
- Heat-treated hardened steel alloy gears & shafts
- Three fixed speeds
- Permanently lubricated transmission
- Thermal overload protection
- Front-mounted touch pad controls with 60-minute digital timer and last-batch recall
- Removable stainless steel, interlocking bowl guard with built-in fully welded ingredient chute
- Interlocked bowl lift
- Motor break quickly stops rotation of the agitator
- Rigid cast iron body
- Industry standard #12 attachment hub
- NSF approved enamel gray paint
- 6-foot cord and ground plug

## Standard Accessories/Attachments

- 40-qt. stainless steel bowl (#304 series)
- Aluminum flat beater
- Stainless steel wire whip
- Aluminum spiral dough hook
- Non-slip rubber feet

## Warranty

- *Two years parts and labor*

## Optional Accessories/Attachments

- Seismic flange kit
- Polycarbonate splash shield insert
- Slicer/shredder/grater for #12 hub
- Meat grinder for #12 hub
- Meat tenderizer for #12 hub
- Strip cutter for #12 hub
- Stainless steel flat beater
- Stainless steel spiral dough hook
- 20-qt. adapter kit

*To select options, see complete list on back ck*

Approved by: \_\_\_\_\_ Date: \_\_\_\_\_

2153 Dryden Rd., Dayton, OH 45439 | 937-299-5493 | 800-347-5423 | Fax: 937-299-4147 | [www.globefoodequip.com](http://www.globefoodequip.com)

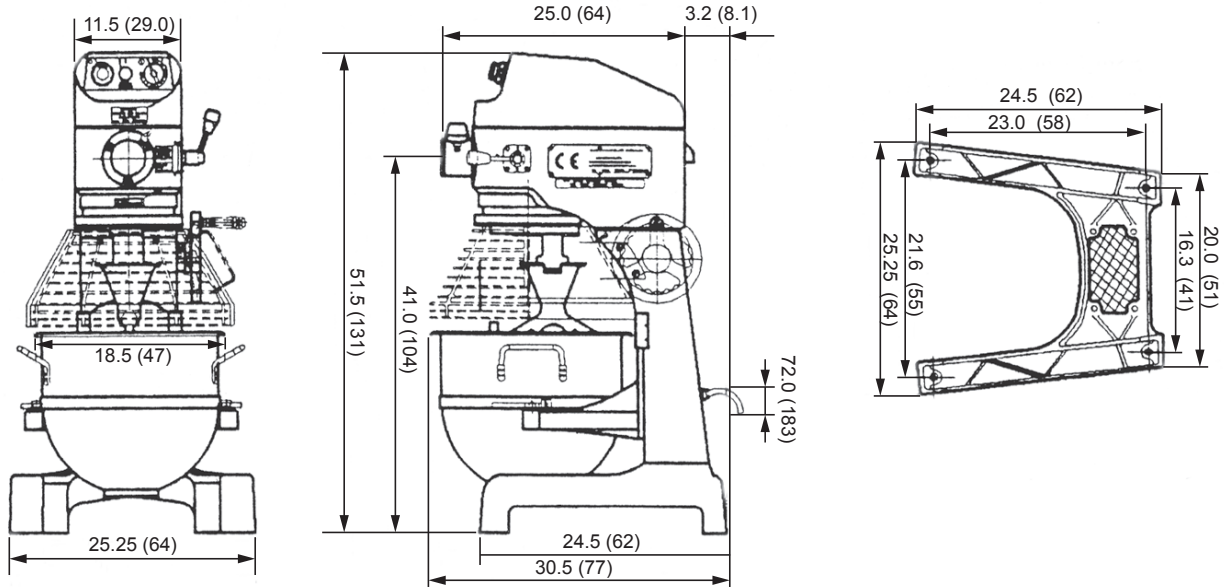

UNIT: INCHES (CM)

Drawings available through KCL at [www.kclcad.com](http://www.kclcad.com).

## SPECIFICATIONS

Model	Motor	Volts	Amps	Transmission Type	Capacity	Controls	Agitator Speeds (RPMs)			Attachment Speeds (RPMs)		
							1st	2nd	3rd	1st	2nd	3rd
SPC40	2 HP	220/60/1* 208/60/3*	12 7	Gear	42 qt 40 liter	Front-mounted digital controls & timer	74	132	272	52	92	190

**Cord & Plug:** Attached 6-foot flexible 3-wire cord with molded plug fits a grounded receptacle. Single phase NEMA L6-30P (Ⓢ) Three phase NEMA L15-20P (Ⓢ)

\*Specify voltage when ordering

## DIMENSIONS | SHIPPING INFORMATION

Carton reinforced for shipping. The weight and dimensions of this reinforced carton are included below and may vary from shipment to shipment.

**This product ships on a pallet. Freight class 85.**

Model	Base Foot Print	Overall Dimensions	Net Weight	Shipping Dimensions	Shipping Weight
SPC40	25.25" W x 24.5" D (64 cm x 62 cm)	25.25" W x 30.5" D x 51.5" H (64 cm x 77 cm x 131 cm)	550 lbs (250 kg)	46" W x 48" D x 65" H (122 cm x 122 cm x 165 cm)	750 lbs (339 kg)

Mixer is constructed of a rigid cast iron body with front-mounted controls and 60-minute digital timer with last-batch recall. Mixer has 2 HP custom built motor with overload protection and gear-driven, high torque permanently lubricated transmission consisting of heat-treated hardened steel alloy gears and shafts. Mixer comes with 40 qt. stainless steel bowl, aluminum flat beater, stainless steel wire whip, aluminum dough hook and non-slip rubber feet. Interlocked with removable stainless steel bowl guard with fully welded ingredient chute. Mixer has #12 attachment hub and interlocked bowl lift. Mixer is NSF and ETL listed. Two-year parts and labor warranty.

## OPTIONAL MIXER ACCESSORIES AND HUB ATTACHMENTS

### MIXER:

- XXSEISMIC KIT-MD** Seismic kit
- XXBGSHIELD-40** Bowl guard shield
- XXBOWL-40** 40qt stainless steel (S/S) bowl
- XXBEAT-40** Alum. flat beater
- XXBEAT-40SS** S/S flat beater
- XXHOOK-40** Alum. dough hook
- XXWHIP-40** S/S wire whip
- XXHDWHIP40-4** Heavy-duty 4 mm S/S wire whip
- XXHDWHIP40-5** Heavy-duty 5 mm S/S wire whip
- XXSCRIP-40** Scraper with mounting kit

- XXACC20-40** Adapter kit - 20 qt bowl, hook, beater and whip

- XBTRUCK-40** Heavy-duty bowl truck

### HUB:

- XVSGH 9"** Slicer/Shredder/Grater housing only (no plates included-must select from plates listed on this sheet)
- XASP** Adjustable slicing plate (for vegetables only)
- XPH** Plate holder \*only 1 required
- L00670** Meat Tenderizer attachment
- L00783** Strip Cutter attachment

### Shredding Plates:

- XSP332\*** 3/32" (2.3 mm)

- XSP316\*** 3/16" (4.7 mm)
- XSP14\*** 1/4" (6.3 mm)
- XSP516\*** 5/16" (7.9 mm)
- XSP12\*** 1/2" (12.7 mm)
- XGP\*** Grating plate
- XMCA-SS** Meat grinder assembly (Polished stainless steel cylinder, worm gear, ring, and s/s pan. Includes knife, 3/16" plate, and pusher)
- XXCK** Chopper knife for XMCA-SS

### Chopper Plate Sizes Available:

- CP02-12** 1/16" (2 mm)
- CP04-12** 5/32" (4 mm)
- CP05-12** 3/16" (5 mm)

- CP06-12** 1/4" (6 mm)
- CP08-12** 5/16" (8 mm)
- CP10-12** 3/8" (10 mm)
- CP12-12** 1/2" (12 mm)
- CP14-12** 9/16" (14 mm)
- CP16-12** 5/8" (16 mm)
- CP18-12** 11/16" (18 mm)
- CP00-12** Stuffing plate
- XST12** 1/2" Stuffing tube (pork)
- XST34** 3/4" Stuffing tube (hog)

- FACTORY INSTALLED OPTION:**  
**XXCORR-40** Correctional package, includes tamper resistant external fasteners.