

Project Name: _____ AIA#: _____

Model #: _____ Location: _____

SIS#: _____ Item #: _____ Quantity: _____



60 Quart Planetary Floor Mixer

**The Perfect Mix of Value,
Performance & Durability**

This award-winning mixer features 3 fixed speeds and front-mounted touch pad controls with a digital timer.



Model

SPC60

Standard Features

- Powerful 3 HP custom built motor
- Gear-driven, high-torque transmission
- Heat-treated hardened steel alloy gears & shafts
- Three fixed speeds
- Permanently lubricated transmission
- Thermal overload protection
- Front-mounted touch pad controls with 60-minute digital timer and last-batch recall
- Removable stainless steel, interlocking bowl guard with built-in, fully welded ingredient chute
- Interlocked bowl lift
- Motor break quickly stops rotation of the agitator
- Rigid cast iron body
- Industry standard #12 attachment hub
- NSF approved enamel gray paint
- 6-foot cord and ground plug

Standard Accessories/Attachments

- 60-qt. stainless steel bowl (#304 series)
- Aluminum flat beater
- Stainless steel wire whip
- Aluminum spiral dough hook
- Non-slip rubber feet
- Bowl truck

Warranty

- *Two years parts and labor*

Optional Accessories/Attachments

- Seismic flange kit
- Polycarbonate splash shield insert
- Slicer/shredder/grater for #12 hub
- Meat grinder for #12 hub
- Meat tenderizer for #12 hub
- Strip cutter for #12 hub
- Stainless steel flat beater
- Stainless steel whip
- Bowl scraper
- Additional bowl truck
- 30-qt. adapter kit
- 40-qt. adapter kit

To select options see back

Approved by: _____

Date: _____

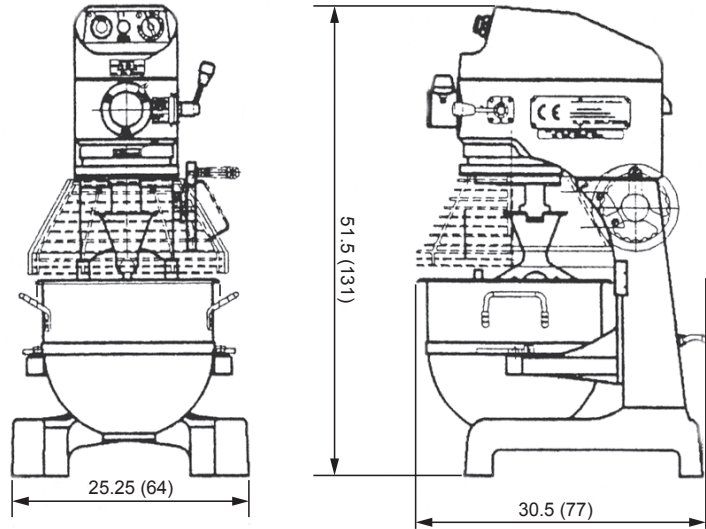

Drawings available through KCL at www.kclcad.com.

SPECIFICATIONS

Model	Motor	Volts	Amps	Transmission Type	Capacity	Controls	Agitator Speeds (RPMs)			Attachment Speeds (RPMs)		
							1st	2nd	3rd	1st	2nd	3rd
SPC60	3 HP	220/60/1* 208/60/3*	23 9	Gear	60 qt / 57 liter	Front-mounted digital controls & timer	73	120	267	49	82	181

Cord & Plug: Attached 6-foot flexible 3-wire cord with molded plug fits a grounded receptacle. Single phase NEMA L6-30P Ⓢ Three phase NEMA L15-20P Ⓢ

**Specify voltage when ordering.*

DIMENSIONS | SHIPPING INFORMATION

Reinforced carton for shipping. The weight and dimensions of this reinforced carton are included below and may vary from shipment to shipment. **This product ships on a pallet. Freight class 85.**

Model	Overall Dimensions	Net Weight	Shipping Dimensions	Shipping Weight
SPC60	25.25" W x 30.5" D x 51.5" H (64 cm x 77 cm x 131 cm)	572 lbs (260 kg)	46" W x 48" D x 65" H (122 cm x 122 cm x 165 cm)	690 lbs (313 kg)

Mixer is constructed of a rigid cast iron body with front-mounted touch pad controls and 60-minute digital timer with last-batch recall. Mixer has 3 HP custom built motor with overload protection and gear-driven, high-torque, permanently lubricated transmission consisting of heat-treated hardened steel alloy gears and shafts. Mixer comes standard with 60-qt. stainless steel bowl, aluminum flat beater, stainless steel bowl truck and wire whip, aluminum dough hook and non-slip rubber feet. Interlocked with removable stainless steel bowl guard with fully welded ingredient chute. Mixer has #12 attachment hub and interlocked bowl lift. Mixer is NSF and ETL listed. Two-year parts and labor warranty.

OPTIONAL MIXER ACCESSORIES AND HUB ATTACHMENTS

MIXER:

- XXSEISMIC KIT-MD** Seismic kit
- XXBGSHIELD-60** Bowl guard shield
- XXBOWL-60** 60 qt stainless steel bowl
- XXBEAT-60** Alum. flat beater
- XXBEAT-60SS** S/S flat beater
- XXHOOK-60** Alum. dough hook
- XXWHIP-60** S/S wire whip
- XXHDWHIP60-4** Heavy-duty 4 mm S/S wire whip
- XXHDWHIP60-5** Heavy-duty 5 mm S/S wire whip
- XXSCRIP-60** scraper with mounting kit
- XXACC30-60** Adapter kit - 30 qt bowl, hook, beater and whip
- XXACC40-60** Adapter kit - 40 qt bowl, hook, beater and whip
- XBTRUCK-60** 60 qt heavy-duty bowl truck

HUB:

- XVSGH** 9" Slicer/Shredder/Grater housing only (no plates included-must select from plates listed on this sheet)
- XASP** Adjustable slicing plate (veg. only)
- XPH** Plate holder

Shredding Plates:

- XSP332*** 3/32" (2.3 mm)
 - XSP316*** 3/16" (4.7 mm)
 - XSP14*** 1/4" (6.3 mm)
 - XSP516*** 5/16" (7.9 mm)
 - XSP12*** 1/2" (12.7 mm)
 - XGP*** Grating plate
- *Only 1 plate holder required*
- XMCA-SS** Meat grinder assembly (Polished stainless steel cylinder, worm gear, ring, and pan. Includes knife, 3/16" plate, and pusher)
 - XXCK** Chopper knife for XMCA-SS

Chopper Plate Sizes Available:

- CP02-12** 1/16" (2 mm)
- CP04-12** 5/32" (4 mm)
- CP05-12** 3/16" (5 mm)
- CP06-12** 1/4" (6 mm)
- CP08-12** 5/16" (8 mm)
- CP10-12** 3/8" (10 mm)
- CP12-12** 1/2" (12 mm)
- CP14-12** 9/16" (14 mm)
- CP16-12** 5/8" (16 mm)
- CP18-12** 11/16" (18 mm)
- CP00-12** Stuffing plate
- XST12** 1/2" Stuffing tube (mutton)
- XST34** 3/4" Stuffing tube (pork)

FACTORY INSTALLED OPTION:

- XXCORR-60** Correctional package, includes tamper resistant external fasteners.