



COUNTERLINE - GRIDDLE

HEAVY DUTY, THERMOSTATIC and MANUAL, GAS



Model shown Model HDG-24

Thermostatic Griddles:

- HDG-18
- HDG-24
- HDG-36
- HDG-48
- HDG-60
- HDG-72

Manual Griddles:

- HDG-18-M
- HDG-24-M
- HDG-36-M
- HDG-48-M
- HDG-60-M
- HDG-72-M

Standard Features

- Available in 18", 24", 36", 48", 60" and 72" widths
- 30,000 BTU (NAT or LP) burner per 12" Thermostatic Models
- 20,000 BTU (NAT or LP) burner per 12" Manual Models
- Electronic spark ignition (battery)
- Reinforced, insulated double wall sides
- 1" thick polished rolled steel plate
- 5" high rear and 4" side splash guards
- 3/4" rear gas connection and pressure regulator
- Protected flue opening
- Exclusive "NO COLD" Zone -Uniform heat distribution across surface
- Each burner equipped with runner tube
- Grease drawers with large capacity
- Fully welded griddle plate with protected exhaust vent

Standard Features of Thermostatic Griddle Models

- "Insta-on" thermostatic controls for precise settings between 200°F and 550°F
- Imbedded load sensing thermostat
- Flame failure safety device

****MANUAL GRIDDLE DO NOT ALLOW SPECIFIC TEMPERATURE OPERATION****

OPTIONS & ACCESSORIES AT ADDITIONAL COST

- Stainless steel stand
- Stainless steel plate shelf with or without cutting board
- Prison package
- Grooved griddle plates
- 2" high insulator base for mounting on refrigerated base
- Chrome plated griddle plates
- Casters

STANDARD CONSTRUCTION SPECIFICATIONS

Exterior Finish: Front, sides and vent are constructed of #3 polished 430 and 304 stainless steel. Bottom and rear are aluminized steel. Sides are reinforced and fully insulated. 5" rear and 4" side splash.

Griddle Plate: 18", 24", 36", 48", 60", 72" wide unit with one 30,000 BTU (NAT or LP) burners every 12" on thermostatic models and one 20,000 BTU (NAT or LP) burners every 12" on manual models. Fully welded, 1" thick polished steel griddle plate with side splash guards, and grease drawer.

Griddle Controls: Independent, "Insta-on" thermostatic controls with uniform temperature range of 200°F to 550°F. (Thermostatic models ONLY)

Legs: Stainless steel 4" adjustable legs.

Gas Heat Control System: Each foot of griddle is heated by a "U" shaped burner. Each burner is controlled by a thermostatic control. For safety, each pilot has a flame failure device. A 3/4" rear gas connection is standard. Units over 48" wide are constructed of two bodies. (Thermostatic models ONLY)



Approval Notes: _____

- Models: HDG-18 HDG-24 HDG-36 HDG-48 HDG-60 HDG-72
 HDG-18-M HDG-24-M HDG-36-M HDG-48-M HDG-60-M HDG-72-M

HDG

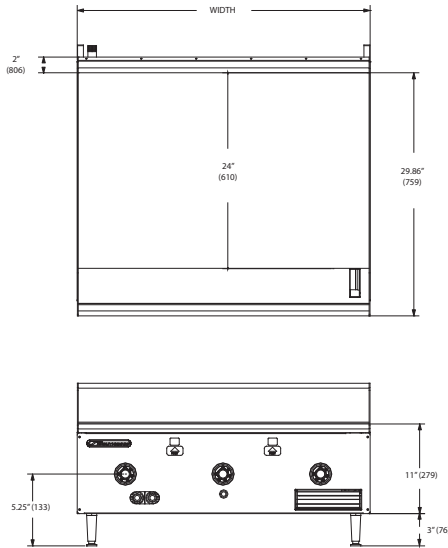

Dimensions shown in inches and (millimeters)

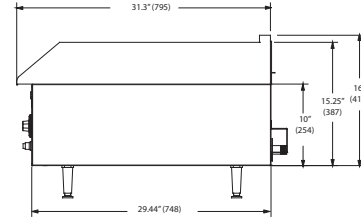

DIMENSIONS

SHIPPING CRATE DIMENSIONS & WEIGHT											
MODEL	WIDTH	NUMBER OF BURNERS	CRATED WIDTH	CRATED DEPTH	CRATED WEIGHT	MODEL	WIDTH	NUMBER OF BURNERS	CRATED WIDTH	CRATED DEPTH	CRATED WEIGHT
HDG-18/ HDG-18-M	18" (457)	1	31" (788)	39" (991)	270 lbs (122 kg)	HDG-48/ HDG-48-M	48" (1220)	4	55" (1398)	39" (991)	545 lbs (247 kg)
HDG-24/ HDG-24-M	24" (610)	2	31" (788)	39" (991)	305 lbs (159 kg)	HDG-60/ HDG-60-M	60" (1525)	5	67" (1703)	45.5" (1157)	705 lbs (320 kg)
HDG-36/ HDG-36-M	36" (915)	3	55" (1398)	39" (991)	445 lbs (202 kg)	HDG-72/ HDG-72-M	72" (1830)	6	110" (2796)	45.5" (1157)	840 lbs (378 kg)

Dimensions shown in inches and (millimeters)

UTILITY INFORMATION

GAS: Each unit has a 3/4" rear gas connection with a male NPT connector (female when regulator is added). Minimum supply pressure is 7" W.C. for natural gas and 11" W.C. for propane. All units require a regulated gas supply. pressure regulator included. If using a flexible hose gas connection, the I.D. of the hose must not be smaller than the connector on the unit and must comply with ANSI Z21.69, providing an adequate means of restraint to prevent undue strain on the gas connection.

MODEL	GAS (BTU/HR)		MODEL	GAS (BTU/HR)	
	NATURAL	PROPANE		NATURAL	PROPANE
HDG-18/ HDG-18-M	30,000	30,000	HDG-48/ HDG-48-M	120,000	120,000
	20,000	20,000		80,000	80,000
HDG-24/ HDG-24-M	60,000	60,000	HDG-60/ HDG-60-M	150,000	150,000
	40,000	40,000		100,000	100,000
HDG-36/ HDG-36-M	90,000	90,000	HDG-72/ HDG-72-M	180,000	180,000
	60,000	60,000		120,000	120,000

MISCELLANEOUS

- If casters are used with flex hose, a restraining device should be used to eliminate undue strain on the flex hose.
- Minimum clearance from noncombustible construction is zero. Minimum clearance from combustible construction is 12" on sides and 8" on rear.
- Install under vented hood.
- Check local codes for fire and sanitary regulations.

NOTICE:

Southbend has a policy of continuous product research and improvement. We reserve the right to change specifications and product design without notice. Such revisions do not entitle the buyer to corresponding changes, improvements, additions or replacements for previously purchased equipment.

DISCLAIMER

1. **Oversized Cookware Use Policy** – "Oversized cookware is considered anything 12" in diameter or larger. Larger vessels may be used to straddle over open top grates (although efficiency may be lost when doing so). It is highly recommended when using oversized cookware that its use be limited to the rear portion of the range. IF oversized cookware is used on the front portion and hangs over onto the front rail, excessive heat may be driven and trapped in the front rail and can cause premature damage to the components housed there. This is easily avoided by never allowing cookware to overlap the front rail of the range. Electrical and other components housed in this area should see years of performance under normal intended use."

**INTENDED FOR COMMERCIAL USE ONLY.
NOT FOR HOUSEHOLD USE.**

