



# IMC VULTURE 904 FLOOR-MOUNTED FOOD WASTE DISPOSER - 3 PHASE [4 WIRE] [AIR BREAK] - W 438 MM - 1.1 KW

## MODEL: F54/731



**Vulture**

Fast and efficient, the 904 Waste Disposer with airbreak enables large kitchens to remove waste quickly and simply. It is able to dispose of 500kg of food waste per hour and handles up to 1000 covers per sitting, making it ideal for larger hotels, hospitals, universities, prisons and food preparation companies.

The 904 Waste Disposer is suitable for medium waste - plate waste, vegetables and peelings, meat and fish scraps, and small bones. The free-standing unit can be welded into tabling with a E30/095 hopper rim, making it quick and easy to load, saving staff time and labour.

### PRODUCT FEATURES

- Fast and efficient disposal of up to 500kg of food waste per hour.
- Handles up to 1000 covers per sitting - ideal for large kitchens.
- For medium waste (plate waste, vegetables and peelings, meat and fish scraps).
- Free-standing design, but can be welded into tabling with E30/095 hopper rim.
- Manually reversible motor to extend operational life.
- With class A airbreak kit - recommended when connecting to a mains water supply.
- Suitable for medium kitchens with three-phase, four-wire power supply.

AIA FILE NUMBER:

ITEM NUMBER:



# IMC VULTURE 904 FLOOR-MOUNTED FOOD WASTE DISPOSER - 3 PHASE [4 WIRE] [AIR BREAK] - W 438 MM - 1.1 KW

## MODEL: F54/731

### WEIGHTS & DIMENSIONS

Width	438 mil
Depth	564 mil
Height	942 mil
Weight	51.5 kg

### SHIPPING DETAILS

Ship Width	62 cm
Ship Depth	48 cm
Ship Height	104 cm
Ship Weight	56.65 kg
Ship Method	Small Parcel (FedEx, UPS, DHL)
Shipping Package Type	Pieces
Shipping Origin Zip Code	LN6 3QZ, UNITED KINGDOM
Quick Ship Product	No

### WATER, PLUMBING, AND DRAINAGE SPECS

Water Line Required	Yes
Water Connection Source Type	Water Main
Water Inlet Size	15 mm
Water Inlet Pressure	0.4 Bar
Drain Line Required	Yes
Drain Outlet Size	2 in

### PRODUCT CERTIFICATIONS



### ENERGY SPECS

Primary Energy Type	Electric	Electrical Plug Type	Hardwired
Electrical Total Amperage	2.8 A	Number of Electrical Plugs	Not Applicable
Electrical Volts	400V	Electrical Connection Type	Direct Hardwired
Electrical Total Wattage	1100 W	Number of Electrical Conductor Wires	1
Electrical Kilowatts	1.1 kW	Dedicated Circuit Required	Yes
Electrical Phase	3-Phase	Electrical Remarks	Three

IMC reserves the right to modify specifications or discontinue models without incurring obligation. Dimensions nominal.

Document Auto-Generated  
March 24, 2025



**IMC VULTURE 904 FLOOR-MOUNTED FOOD WASTE DISPOSER - 3  
PHASE [4 WIRE] [AIR BREAK] - W 438 MM - 1.1 KW**

**MODEL: F54/731**

**ADDITIONAL SPECIFICATIONS**

Airbreak	Yes	Operator Safety Method	Interlock
Construction Materials	Stainless Steel	Self-Cleaning Capable	No
Control Type	On/Off	Waste Processing Capacity Per Hour: Weight	500 kg
Meal Waste Servings Processed Per Sitting	1000	Waste Types Processed	Medium (small pork/ chicken bones, vegeta- bles and fruit)
Motor Power	1.5 hp		

**BIDDING SPECIFICATIONS (SHORT FORM SPECS)**

Bidding Specifications Not Available.



**IMC VULTURE 904 FLOOR-MOUNTED FOOD WASTE DISPOSER - 3  
PHASE [4 WIRE] [AIR BREAK] - W 438 MM - 1.1 KW**

**MODEL: F54/731**

**TECHNICAL DRAWING**

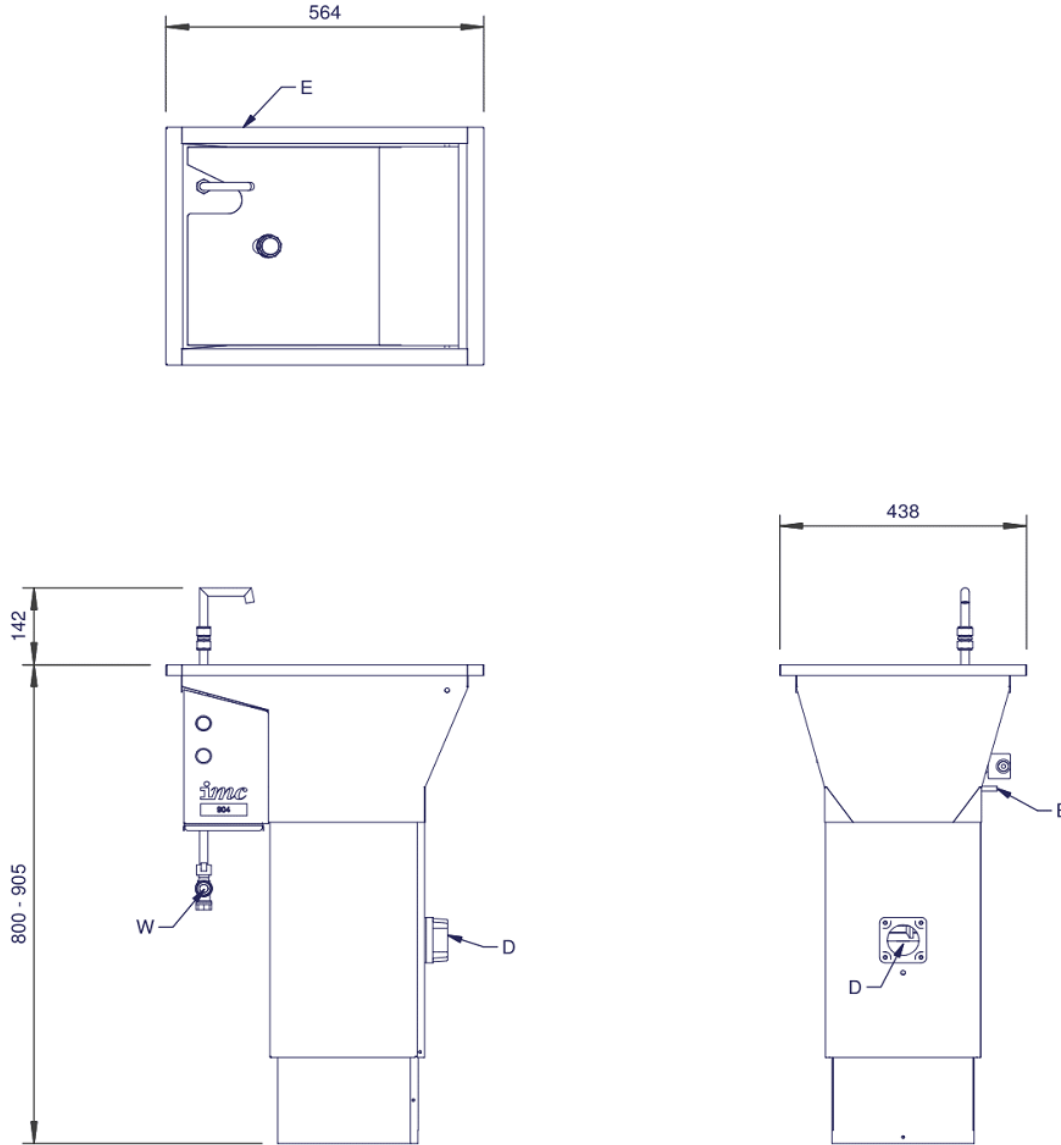

IMC reserves the right to modify specifications or discontinue models without incurring obligation. Dimensions nominal.

Document Auto-Generated  
March 24, 2025

