



**IMC MF5L COUNTER-TOP VEGETABLE PEELER - WITH  
CARBORUNDUM LINER - 1 PHASE - W 366 MM - 0.25 KW**

**MODEL: F59/500/L**



**MF**  
MULTI-FUNCTIONAL  
PEELER

The versatile, energy-efficient MF5L (1PH) is the ideal peeler for small to medium kitchens with a single-phase power supply.

With a carborundum liner and thick peeling plate for long operating life, the MF5L (1PH) is able to peel up to 134kg of vegetables per hour in 5kg batches making it a cost-effective and labour-saving solution.

Easy to operate with built-in controls, the unit has an interlocking lid and door for user safety. To ensure perfect results every time, the MF5L (1PH) has a perspex viewing pane to monitor progress, and an adjustable timer for accurate, repeatable

#### PRODUCT FEATURES

- Able to peel up to 134kg of vegetables per hour - in 5kg batches
- With carborundum liner to reduce peeling times even further
- Interlocking lid and door ensure safe operation
- Perspex viewing pane allows you to monitor the peeling progress
- Adjustable timer ensures accurate, repeatable peeling time
- Modular construction facilitates easy maintenance
- Thicker peeling plate delivers longer operating life
- Suitable for small to medium kitchens with single-phase power supply

A/A FILE NUMBER:

ITEM NUMBER:



# IMC MF5L COUNTER-TOP VEGETABLE PEELER - WITH CARBORUNDUM LINER - 1 PHASE - W 366 MM - 0.25 KW

## MODEL: F59/500/L

### WEIGHTS & DIMENSIONS

Width	366 mil
Depth	519 mil
Height	634 mil
Weight	31.5 kg

### SHIPPING DETAILS

Ship Width	51 cm
Ship Depth	39 cm
Ship Height	60 cm
Ship Weight	34.65 kg
Ship Method	Small Parcel (FedEx, UPS, DHL)
Shipping Package Type	Pieces
Shipping Origin Zip Code	LN6 3QZ, UNITED KINGDOM
Quick Ship Product	No

### WATER, PLUMBING, AND DRAINAGE SPECS

Drain Line Required	Yes
Drain Outlet Size	38 mm

### PRODUCT CERTIFICATIONS



### ENERGY SPECS

Primary Energy Type	Electric
Electrical Total Amperage	1.6 A
Electrical Volts	230V
Electrical Total Wattage	250 W
Electrical Kilowatts	0.25 kW
Electrical Phase	1-Phase

Electrical Plug Type	Hardwired
Number of Electrical Plugs	Not Applicable
Electrical Connection Type	Direct Hardwired
Number of Electrical Conductor Wires	1
Dedicated Circuit Required	Yes
Electrical Remarks	Single

### ADDITIONAL SPECIFICATIONS

Airbreak	Yes
Construction Materials	Stainless Steel
Control Type	On/Off, Rotary Control Knob
Hopper Load	5 kg
Motor Power	0.33 hp
Operator Safety Method	Interlock
Processing Capacity Per Hour	134 kg
Timer Type	Mechanical/Traditional Timer

### BIDDING SPECIFICATIONS (SHORT FORM SPECS)

Bidding Specifications Not Available.



IMC MF5L COUNTER-TOP VEGETABLE PEELER - WITH CARBORUNDUM LINER - 1 PHASE - W 366 MM - 0.25 KW

MODEL: F59/500/L

TECHNICAL DRAWING

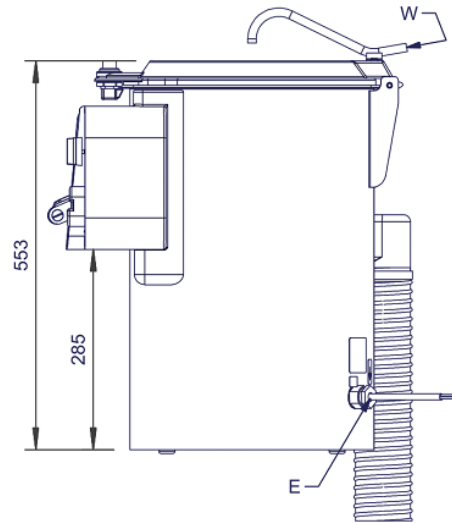
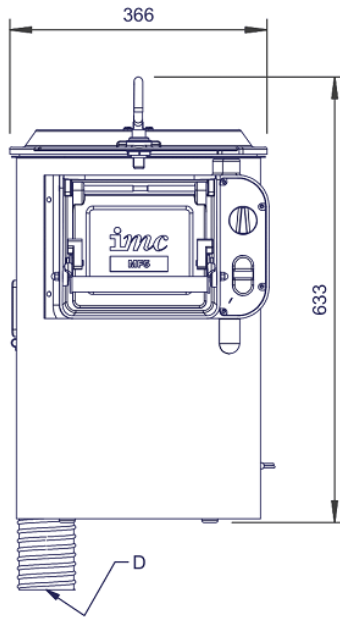
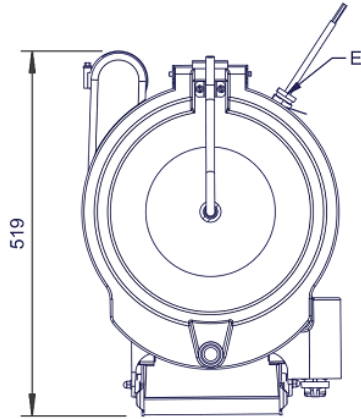

IMC reserves the right to modify specifications or discontinue models without incurring obligation. Dimensions nominal.

Document Auto-Generated  
March 24, 2025

