



PRODUCT OPTIONS AND ACCESSORIES

- S59/164 Carborundum Peeling Plate for MF10/MF10L/MF15/MF15L Vegetable Peeler
- E72/011 Sink Skip - Stainless Steel - for MF10/MF10L/MF15/MF15L/VQ Peeler

The versatile, energy-efficient MF15L (3PH) is the ideal peeler for medium to large kitchens with a three-phase power supply.

With a carborundum liner and thick peeling plate for long operating life, the MF15L (3PH) is able to peel up to 500.8kg of vegetables per hour in 15kg batches making it a cost-effective and labour-saving solution.

Easy to operate, the unit comes with an integral stand and removable filter basket. It has an interlocking lid and door for user safety. The MF15L (3PH) has a perspex viewing pane to monitor progress, and an adjustable timer for accurate,

PRODUCT FEATURES

- Able to peel up to 500.8kg of vegetables per hour - in 15kg batches.
- With carborundum liner to reduce peeling times even further.
- Interlocking lid and door ensure safe operation.
- Perspex viewing pane allows you to monitor the peeling progress.
- Adjustable timer ensures accurate, repeatable peeling times.
- Modular construction facilitates easy maintenance.
- Thicker peeling plate delivers longer operating life.
- Suitable for medium to large kitchens with three-phase power supply.

AIA FILE NUMBER:

ITEM NUMBER:



IMC MF15L FREE-STANDING VEGETABLE PEELER - WITH CARBORUNDUM LINER - 3 PHASE - W 481 MM - 0.37 KW

MODEL: F59/521/L

WEIGHTS & DIMENSIONS

Width	481 mil
Depth	635 mil
Height	1177 mil
Weight	52 kg

SHIPPING DETAILS

Ship Width	68 cm
Ship Depth	51 cm
Ship Height	125 cm
Ship Weight	57.2 kg
Ship Method	Small Parcel (FedEx, UPS, DHL)
Shipping Package Type	Pieces
Shipping Origin Zip Code	LN6 3QZ, UNITED KINGDOM
Quick Ship Product	No

WATER, PLUMBING, AND DRAINAGE SPECS

Drain Line Required	Yes
Drain Outlet Size	38 mm

PRODUCT CERTIFICATIONS



ENERGY SPECS

Primary Energy Type	Electric
Electrical Total Amperage	3.6 A
Electrical Volts	400V
Electrical Total Wattage	370 W
Electrical Kilowatts	0.37 kW
Electrical Phase	3-Phase

Electrical Plug Type	Hardwired
Number of Electrical Plugs	Not Applicable
Electrical Connection Type	Direct Hardwired
Number of Electrical Conductor Wires	1
Dedicated Circuit Required	Yes
Electrical Remarks	Three

ADDITIONAL SPECIFICATIONS

Airbreak	Yes
Construction Materials	Stainless Steel
Control Type	On/Off, Rotary Control Knob
Hopper Load	15 kg
Motor Power	0.5 hp
Operator Safety Method	Interlock
Processing Capacity Per Hour	500.8 kg
Timer Type	Mechanical/Traditional Timer

BIDDING SPECIFICATIONS (SHORT FORM SPECS)

Bidding Specifications Not Available.

IMC reserves the right to modify specifications or discontinue models without incurring obligation. Dimensions nominal.

Document Auto-Generated
March 24, 2025



IMC MF15L FREE-STANDING VEGETABLE PEELER - WITH CARBORUNDUM LINER - 3 PHASE - W 481 MM - 0.37 KW

MODEL: F59/521/L

TECHNICAL DRAWING

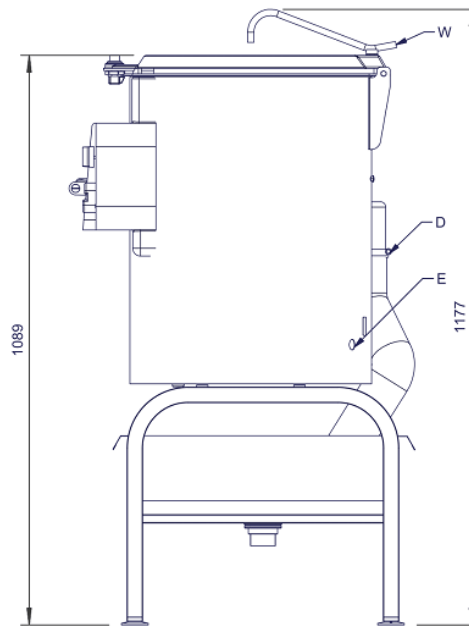
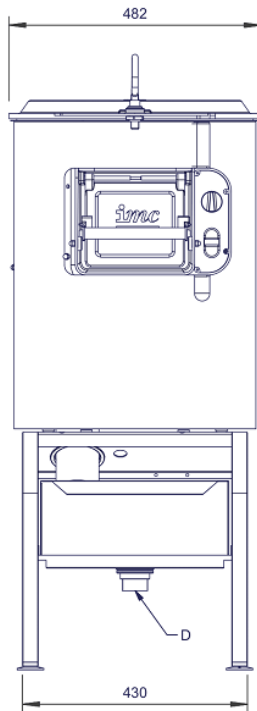
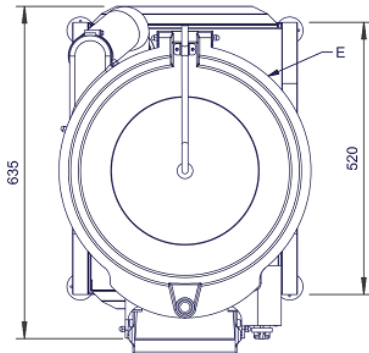

IMC reserves the right to modify specifications or discontinue models without incurring obligation. Dimensions nominal.

Document Auto-Generated
March 24, 2025