

# Maestro Plus™

self-contained 425 series Chewblet® RIDE® ice machine



MCD425ABS shown



## Features

Maestro Plus Chewblet ice machine with up to 425 lb (193.0 kg) daily production of consumer-preferred Chewblet ice

- automatically transport ice through a tube with RIDE technology from up to 20' (6 m) away
- available with approximately 1.00" (2.54 cm) long standard Chewblet ice
- environmentally responsible R404a refrigerant has zero ozone depletion potential
- water and energy efficient
- no noisy harvest cycles means quiet ice production

## Consumer-preferred Chewblet ice

- preferred over cubes by more than 2:1<sup>1</sup>
- easy to chew
- more reliable dispensing than nugget or pellet ice
- slow melting, maintains drink temperature and quality comparable to cubes
- higher displacement than cube ice

## Key Maestro Plus design features

- durable construction, versatile design – sturdy stainless steel exterior frame
- stainless steel evaporator, auger and top bearing
- oversized, heavy duty, tapered roller bearings ensure long, low-maintenance life
- automatic self-flushing of ice machine removes impurities
- compact design offers in-cabinet/undercounter, floor stand, wall bracket, on-fountain dispenser, or on-bin mounting
- 10 ft (3 m) flexible ice transport tube and insulation standard with RIDE model ice machines (except for "V" models)

## Maintenance and service benefits

- cleaning and sanitizing of entire machine takes less than 1 hour
- LED control board provides at-a-glance machine status

## Warranty

- 3 years parts and labor, 5 years compressor parts<sup>2</sup>

<sup>1</sup> Consumer study conducted by independent agency Roper ASW.

<sup>2</sup> Refer to price list for additional warranty information.

Model configurations				
For use with <sup>1</sup>	Install/mount	Condenser	V/Hz/Ph	Item number
ice storage bin	RIDE	air	115/60/1	<b>MCD425ABS†</b>
		water	115/60/1	<b>MCD425WBS</b>
Follett Vision™ dispenser	RIDE	air	115/60/1	<b>MCD425AVS†</b>
		water	115/60/1	<b>MCD425WVS</b>
ice and beverage dispenser (by others)	RIDE	air	115/60/1	<b>MCD425AHS†</b>
		water	115/60/1	<b>MCD425WHS</b>

† ENERGY STAR® certified

<sup>1</sup> Ordered separately

## Accessories

- Water filters (see form# 1058)
- Nu-Calgon IMS-III sanitizer, 16 oz bottle (item# 00979674)
- SafeCLEAN Plus™ ice machine cleaner
  - 6 x 8 oz (237 ml) bottles (item# 01149954)
  - Carton of 24 x 8 oz (237 ml) bottles (item# 01149962)
- Wall mount bracket (see form# 3311)
- Slide-out track accessory – allows RIDE model ice machines to slide-out without disconnecting utilities (see form# 3311)
- Ice machine stand, height-adjustable (see form# 3311)
- Longer ice transport tube (10'3 m is standard) – Specify length:
  - \_\_\_\_ ft/m in 5'/1.5 m increments (20' max)

## Specification

<b>W1</b> Width	18.80" (47.8 cm)
Depth	<b>D1</b> air-cooled – 22.09" (56.1 cm) <b>D2</b> water-cooled – 20.00" (50.8 cm)
<b>H1</b> Height	17.10" (43.4 cm)
Service clearance	12.00" (30.5 cm) top – no front obstructions 6.00" (15.24 cm) on exhaust side (left, right and rear)
<b>C1</b> Electrical	11 amps, 0.8 kW, requires dedicated 115 V/60/1 15 amp circuit, 7' (2 m) cord, NEMA 5-15 plug
<b>C2</b> Ice transport tube	see page 7 for details
<b>C3</b> Water inlet	3/8" FPT
<b>C4</b> Drain	3/4" MPT water-cooled models require separate condenser drains
Water-cooled ice machine connections	<b>C5</b> – 3/8" FPT condenser inlet <b>C6</b> – 3/8" FPT condenser drain
Air temperature	50 - 100 F (10 - 38 C)
Water temperature	45 - 90 F (10 - 32 C)
Potable water pressure	10 - 70 psi (69 - 483 kPa)
Condenser water pressure	10 - 125 psi (69 - 861 kPa)
Ice production at 70 F (21 C) air, 50 F (10 C) water	air-cooled models – 425 lb (193.0 kg) water-cooled models – 443 lb (201.1 kg)
Ice production at 90 F (32 C) air, 70 F (21 C) water	air-cooled models – 325 lb (147.6 kg) water-cooled models – 372 lb (169.0 kg)
Energy consumption	air-cooled models – 5.4 kWh 90 F (32 C) air, 70 F (21 C) water water-cooled models – 5.0 kWh per 100 lb (45.4 kg) ice
Heat rejection	air-cooled models – 5,000 BTU/hr water-cooled models – 1,400 BTU/hr to air, 3,600 BTU/hr to water
Water consumption	12.0 gal (45.4 L) of potable water per 100 lb (45.4 kg) of ice
Water flow requirement for water-cooled models	0.25 gpm at 50 F (10 C) 0.5 gpm at 70 F (21 C) 1.25 gpm at 90 F (32 C)
Approximate net weight	150 lb (68 kg)
Approximate ship weight	160 lb (73 kg)

NOTE: For indoor use only

SHORT FORM SPECIFICATION: Ice machine to be a Follett® model number \_\_\_\_\_ [condenser type, from model number guide] capable of producing compressed nugget ice using an efficient, sanitary vertical evaporator/auger system and delivering ice by a flexible wire reinforced, transport tube to  ice storage bin, or  ice and beverage dispenser and provided with a stainless steel frame, plus all the features listed and mounting/performance-enhancing accessories checked above.

Ice machine to be equipped with automatic self-flushing.

## Dimensional drawing

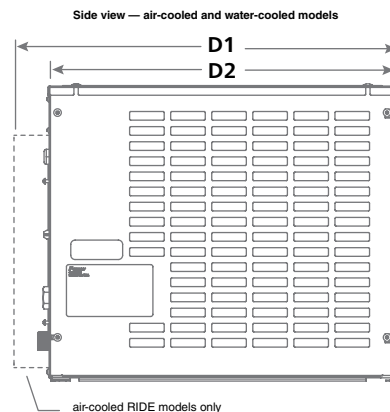
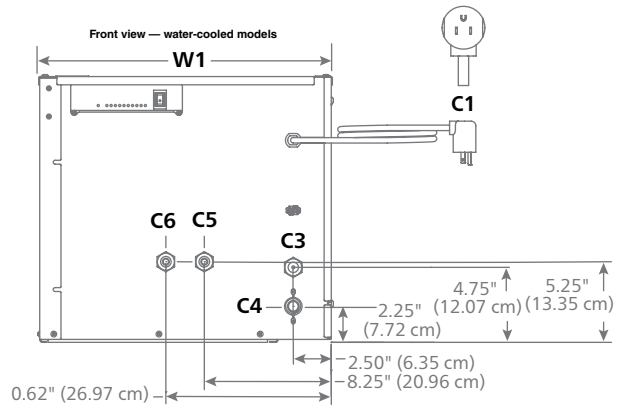
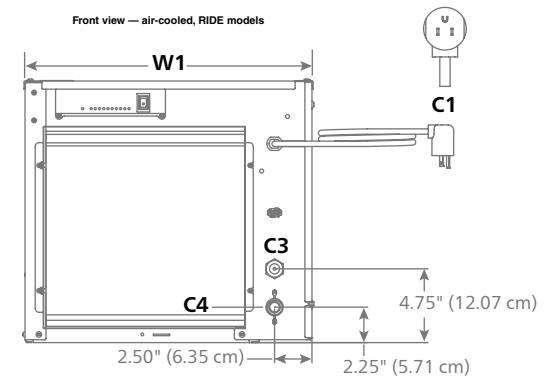
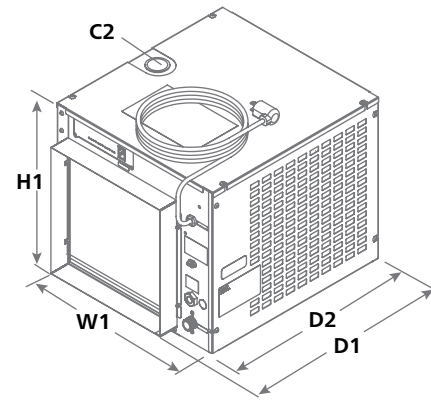

# 1 – Locating the ice machine

Maestro Plus self-contained Chewblet ice machines with RIDE technology allow mounting in a base cabinet, on a wall or on a floor stand up to 20' (6 m) from the dispenser or ice bin. In-cabinet mounting requires special attention to service access, unit ventilation and ice tube runs.

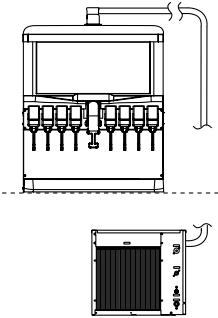
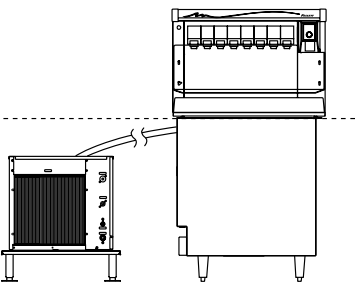
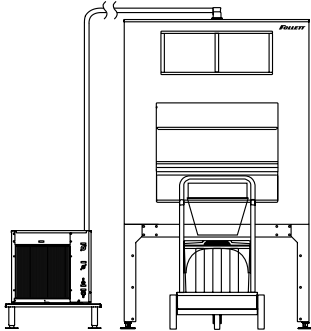
RIDE model – ice and beverage dispensers (by others)	RIDE model – Follett low-profile Vision ice and beverage dispensers	RIDE model – Follett ice storage bins
		
<p><b>Important specifier notes</b></p>	<p><b>Important specifier notes</b></p>	<p><b>Important specifier notes</b></p>
<ol style="list-style-type: none"> <li>1. Dispenser must be compatible with nugget ice. Compatible dispensers include Cornelius DB/DF/ED, 150 BC, 175 BC, 200 BC, 250 BC, 300 BC, IDC215/255, FlavorFusion/Overload, Lancer 4500-22N, 4500-30N, FS16N, FS30N, FS44N, Servend MD150/175/200/250, MDH302/402, SV175/200/250 and Coca-Cola Freestyle.</li> <li>2. Ice enters through the top of the ice and beverage dispenser. Contact factory for side entry.</li> <li>3. Coca-Cola Freestyle 7000 requires top kit MSF30SC. Top adapter IC CODE 46412 and ice kit IC Code 46430 must also be ordered from Coca-Cola. Coca-Cola Freestyle 7100 requires top adapter IC Code 46751 and ice kit IC Code 46430 only, and must be ordered from Coca-Cola. Coca-Cola Freestyle 9100 requires top kit MSF26SC. Consult with Coca-Cola and Follett to qualify application prior to ordering.</li> <li>4. RIDE application is approved only for Pepsi Spire 3.0, 5.0 and 4.1 designed for top mount ice machines and requires MSP24SC for 3.0 and MSP30SC for 5.0 and 4.1, ordered separately. For manual fill versions of Pepsi Spire 3.0, 5.0 and 4.1, contact factory.</li> </ol>	<ol style="list-style-type: none"> <li>1. See pages 4-6 for critical clearance and venting requirements.</li> </ol>	<ol style="list-style-type: none"> <li>1. See form# B300 for bin sizing.</li> <li>2. Locate floor sink or grate and drains in front of storage bin.</li> <li>3. Do not position bin drain lines to block Ice•Device™ bin cart.</li> </ol>

## 2 – Undercounter/in-cabinet mounting

### Cabinet details

#### Important specifier notes

1. Cabinet door opening must meet minimum size requirements shown and be free of obstructions to allow ice machine to slide out (no lip or utilities to block removal).
2. Cabinet base must be capable of supporting ice machine and allow ice machine to rest flat on cabinet bottom.
3. No counter supports, electric or plumbing can run in front of the ice machine.

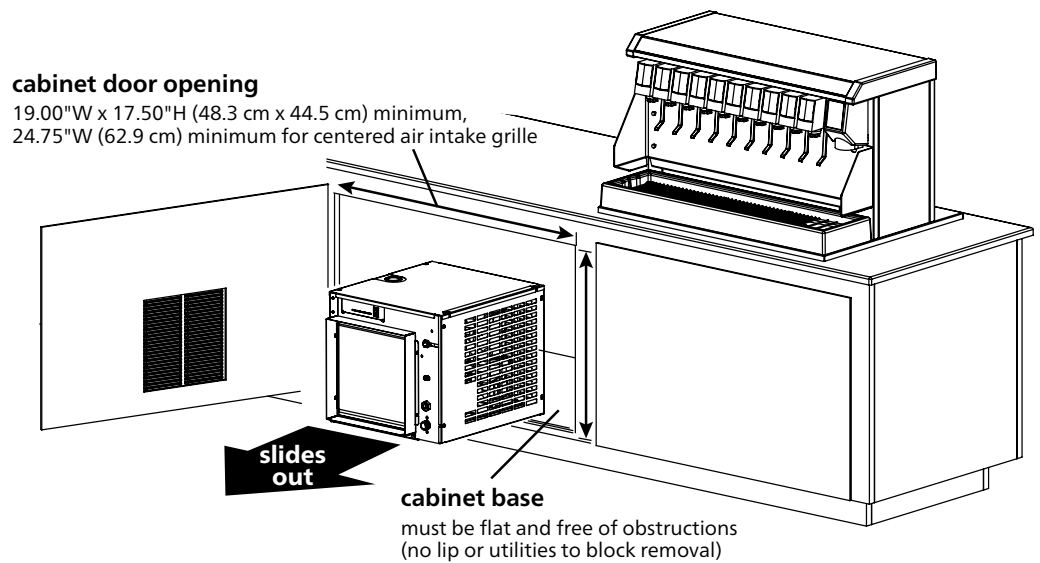

### 3 – Undercounter/in-cabinet mounting and ventilation

#### Using Follett supplied grilles

Maestro Plus ice machines can be installed undercounter/in-cabinet to fill bins or dispensers using RIDE technology. Care must be taken to ensure proper cabinet venting to avoid recirculation of hot air. Improper venting can cause ice machine outages.

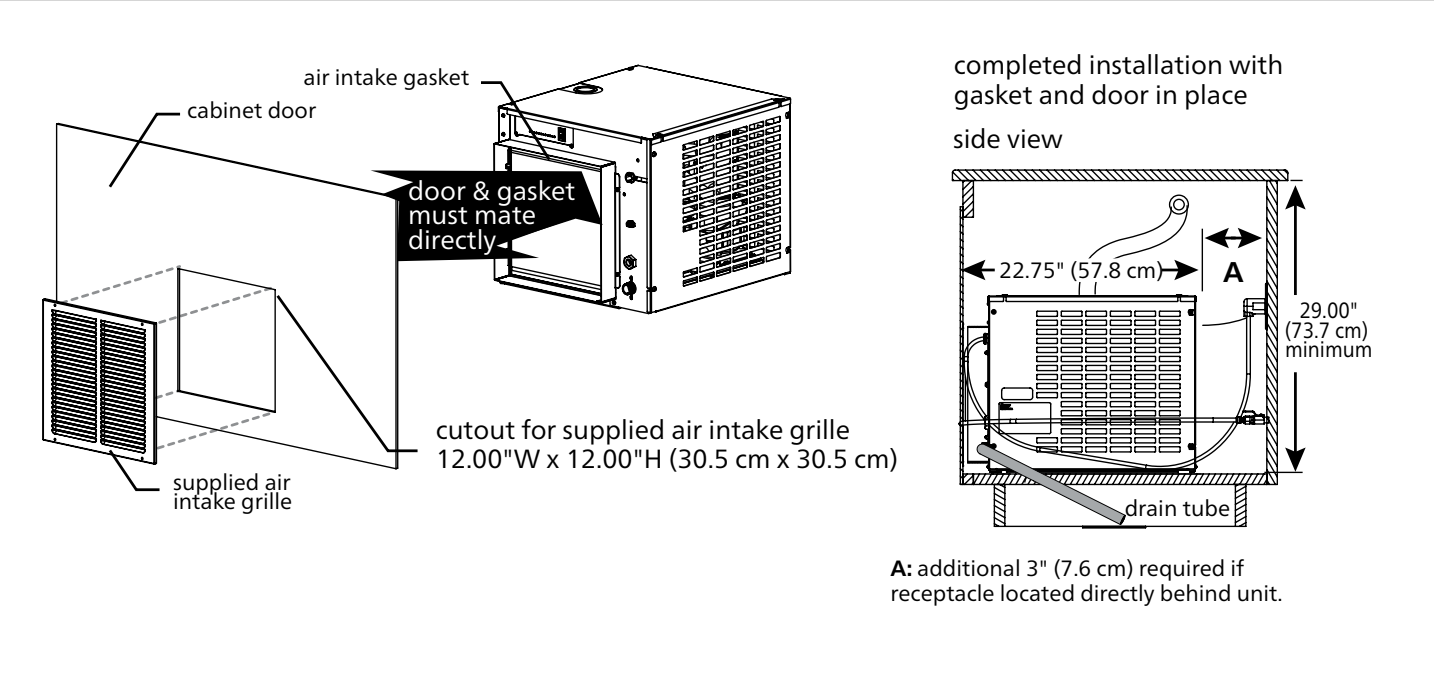
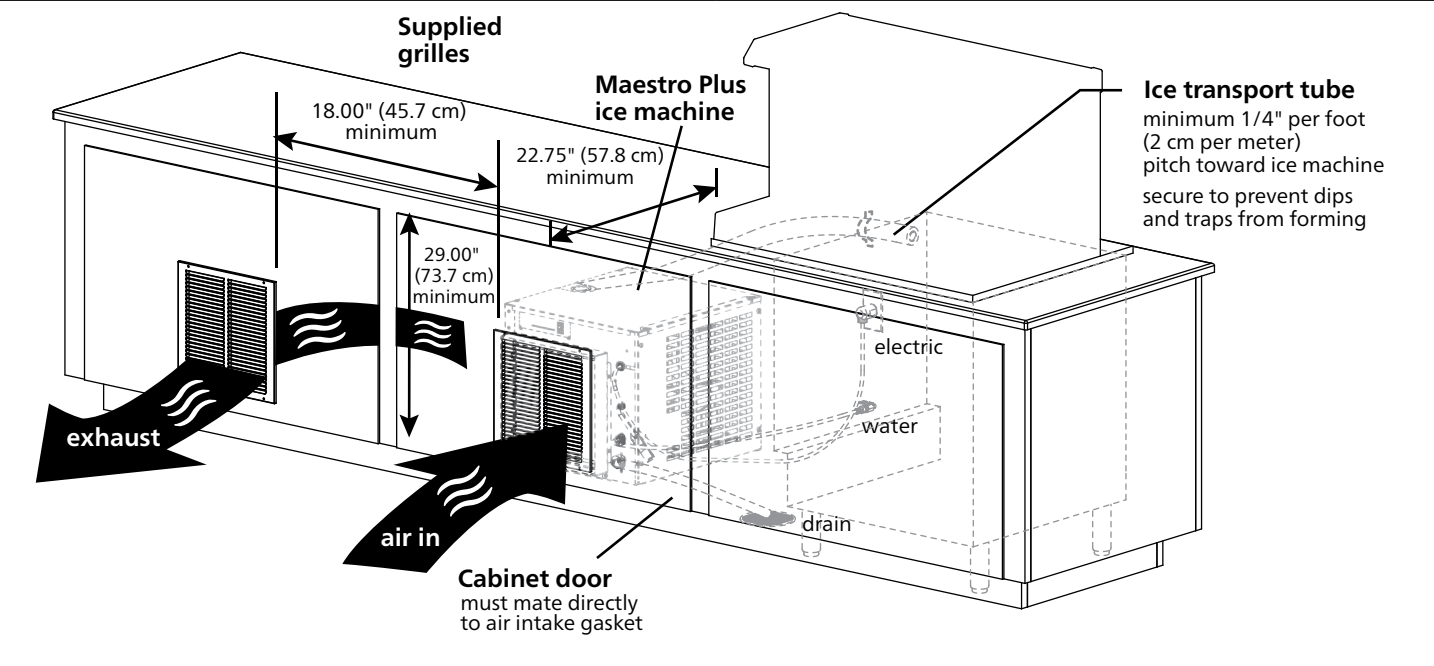

#### Important specifier notes for using Follett supplied grilles

- |   |  |
|---|--|
| <ol style="list-style-type: none"> <li>1. The supplied exhaust grille must be located at least 18.00" (45.7 cm) from the supplied air intake grille (exhaust air must not recirculate with intake air).</li> <li>2. Cabinet interior must be open to allow for unrestricted exhaust air flow.</li> <li>3. Ice transport tube needs minimum 1/4" per foot (2 cm per meter) pitch toward ice machine and should be secured to prevent dips and traps from forming.</li> </ol> | <ol style="list-style-type: none"> <li>4. Cabinet door must mate directly to air intake gasket.</li> <li>5. Cabinet interior must provide a minimum clear space of 22.75" deep (57.8 cm) by 29.00" high (73.7 cm).</li> <li>6. Supplied grilles must meet minimum requirements for open air space shown above.</li> <li>7. Utilities should be conveniently located as shown.</li> </ol> |
|---|--|

### 3 – Undercounter/in-cabinet mounting and ventilation (continued)

#### Using grilles by others/alternate cabinet ventilation

Cabinets with ventilation or louvers other than those provided by Follett require special consideration to provide proper ventilation. Recirculation of hot air will reduce ice machine performance and can cause ice machine outages.

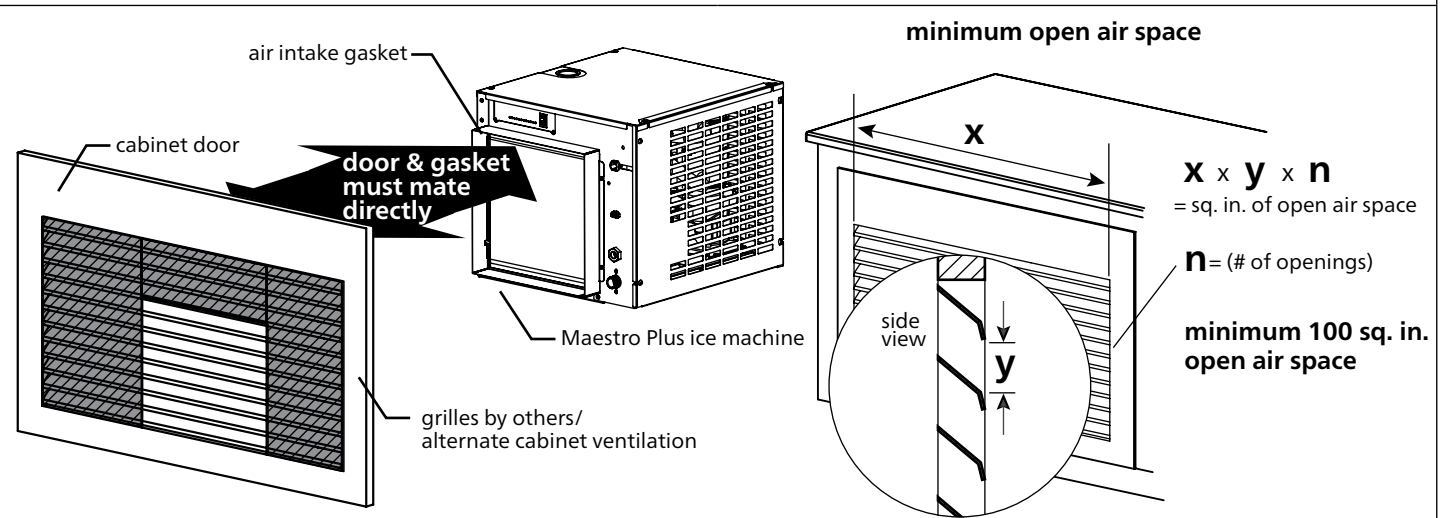
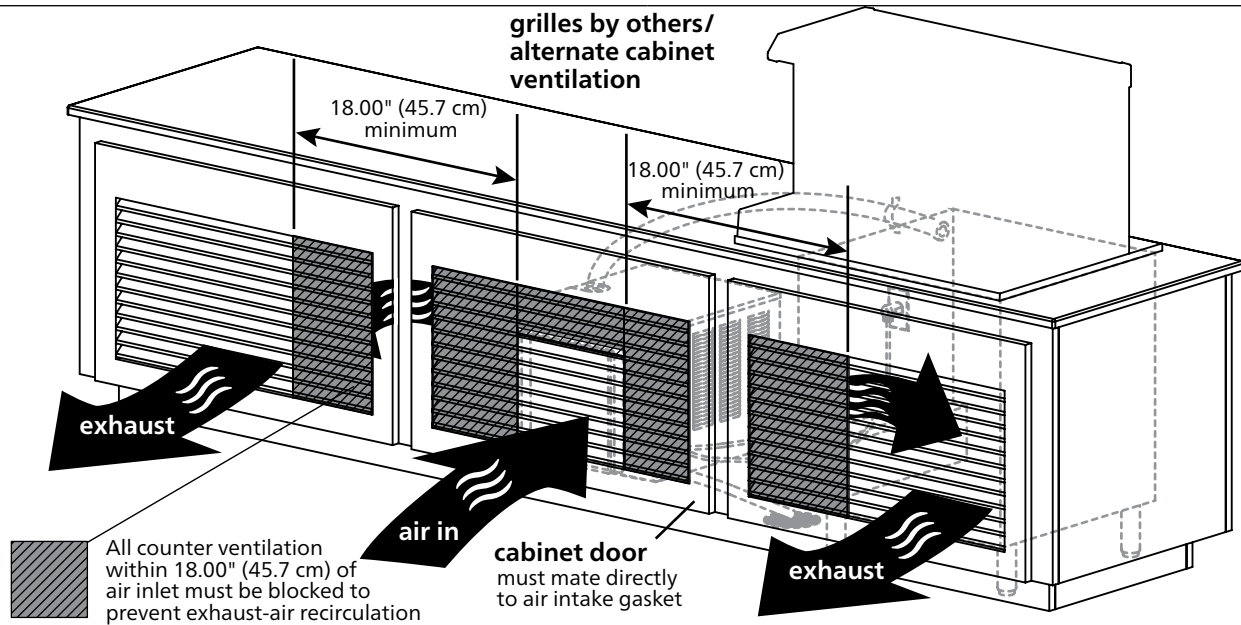

#### Important specifier notes for using grilles supplied by others/alternate cabinet ventilation

1. Exhaust must be at least 18.00" (45.7 cm) from air intake (exhaust must not recirculate with intake air).
2. Cabinet interior must be open to allow for unrestricted exhaust air flow.
3. Ice transport tube needs minimum 1/4" per foot (2 cm per meter) pitch toward ice machine and should be secured to prevent dips and traps from forming.
4. Ducting must be provided if cabinet door does not mate directly to air intake gasket.
5. Cabinet interior must provide a minimum clear space of 22.75" deep (57.8 cm) by 29.00" high (73.7 cm).
6. Grilles by others must meet minimum requirements for open air space shown above.
7. Utilities should be conveniently located as shown.

## 4 – Maestro Plus ice machine mounting accessories

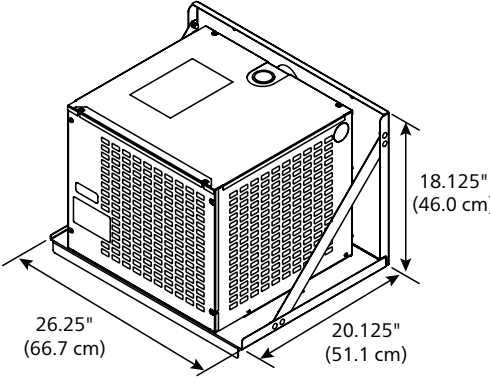
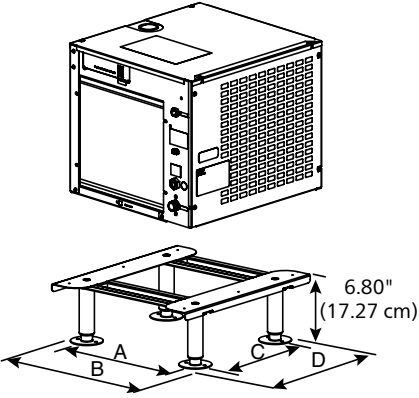
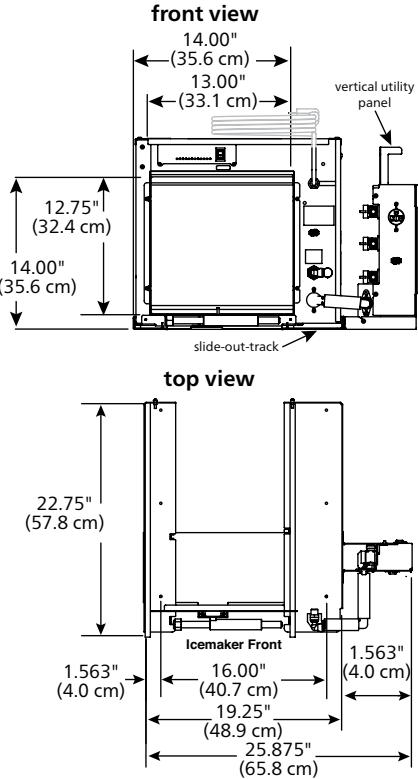
Optional wall mount bracket	Optional machine stand	Optional slide out accessory
 <p>26.25" (66.7 cm) 18.125" (46.0 cm) 20.125" (51.1 cm)</p>	 <p>6.80" (17.27 cm)</p> <p>A - 15.125" (38.4 cm) C - 13.25" (33.6 cm) B - 18.625" (47.3 cm) D - 20.75" (52.7 cm)</p>	 <p><b>front view</b> 14.00" (35.6 cm) 13.00" (33.1 cm) 12.75" (32.4 cm) 14.00" (35.6 cm) vertical utility panel slide-out-track</p> <p><b>top view</b> 22.75" (57.8 cm) 1.563" (4.0 cm) 16.00" (40.7 cm) 19.25" (48.9 cm) 25.875" (65.8 cm) 1.563" (4.0 cm) Icemaker Front</p>

### Important specifier notes

- For secure wall mounting, specify optional wall mount bracket.
- Wall and fasteners must support the weight of the ice machine, bracket, supply water and ice. Use of a backing board may be required with hollow wall construction.
- Machine stand mounting adds 6.80" (17.27 cm) to height of ice machine.
- No dips in tube routing allowed.
- Ice transport tube needs minimum 1/4" per foot (2 cm per meter) pitch toward ice machine and should be secured to prevent dips and traps from forming.

## 5 – Maestro Plus ice tube runs – specifier guidelines

### Long tube runs for RIDE remote ice delivery equipment

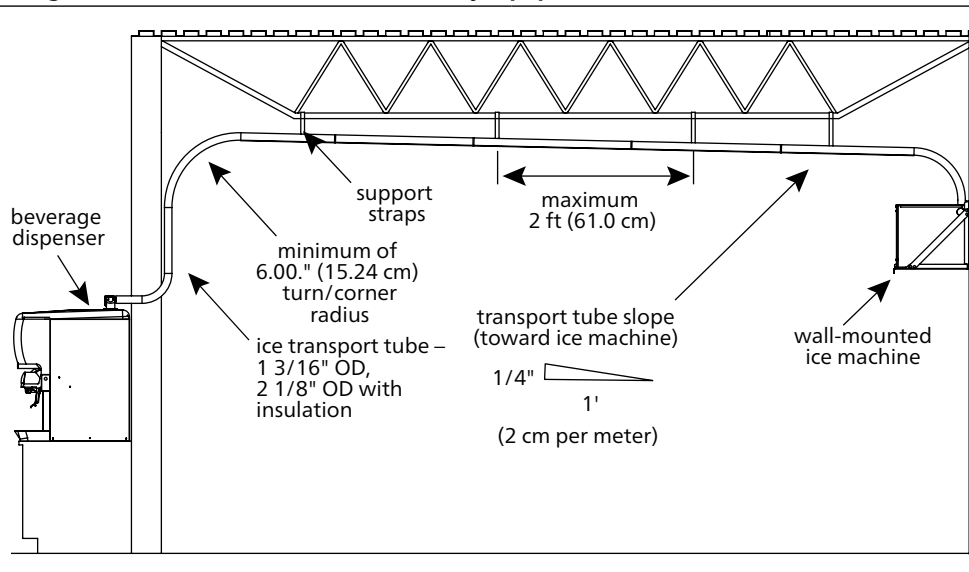

### Important specifier notes:

- 20' (6 m) maximum ice transport tube run.
- Tubing routing bends must have a 6.00" (15.24 cm) radius or larger.
- If not supported from underneath, secure insulated ice transport tube at least every 2' (61.0 cm) to prevent dips or traps.
- Relative humidity levels above 80% in areas where the ice machine or ice transport tube are located may produce excessive condensation that will cause water damage.
- Contact factory for recommendations on running tubing through a decorative soffit or chase.

## Ice production – air-cooled

Inlet water temperature F (C)	Ambient air temperature F (C)					lb/kg production in 24 hr
	60 (16)	70 (21)	80 (27)	90 (32)	100 (38)	
50 (10)	460 (208)	425 (193)	390 (177)	355 (161)	320 (145)	
60 (16)	438 (198)	405 (184)	373 (169)	340 (154)	307.5 (139)	
70 (21)	415 (188)	385 (190)	355 (173)	325 (147)	295 (134)	
80 (27)	405 (184)	375 (170)	345 (156)	315 (142)	285 (129)	
90 (32)	395 (179)	365 (166)	335 (152)	305 (138)	275 (125)	

## Ice production – water-cooled

Inlet water temperature F (C)	Condenser water temperature F (C)						lb/kg production in 24 hr
	50 (10)	60 (16)	70 (21)	80 (27)	90 (32)	100 (38)	
50 (10)	486 (220)	465 (211)	443 (201)	422 (191)	400 (181)	389 (176)	
60 (16)	464 (210)	445 (202)	425 (193)	406 (184)	386 (175)	367 (166)	
70 (21)	443 (201)	425 (193)	408 (185)	390 (177)	372 (169)	358 (162)	
80 (27)	422 (191)	406 (184)	389 (176)	373 (169)	356 (161)	340 (154)	
90 (32)	400 (181)	385 (175)	371 (168)	356 (161)	341 (155)	326 (148)	

ENERGY STAR and the ENERGY STAR mark are registered trademarks owned by the U.S. Environmental Protection Agency.  
 ICE•DEVICE, MAESTRO PLUS and VISION are trademarks of Follett Products, LLC.  
 CHEWBLET, FOLLETT and RIDE are registered trademarks of Follett Products, LLC, registered in the US.  
 Follett reserves the right to change specifications at any time without obligation. Certifications may vary depending on country of origin.

## Self-contained 425 series RIDE ice machine

