



ELECTRIC



SPEC SERIES 36" WAFER PLATE RANGES



IHR-6-EW

Shown with optional casters

MODEL NUMBERS:

IHR-6-EW
IHR-6-EW-C
IHR-6-EW-XB

10" x 10" wafer heating elements heat up to 650°.



High performance 5.3 KW element provides even heating throughout the oven.

PLATE ELEMENTS

- 650° maximum temperature heats food up to 50% faster.
- Heating elements are 10" x 10" (254 x 254) for maximum pan contact.
- Features 12" x 12" (305 x 305) wafer plates in front, and 12" x 13" (305 x 330) in rear.
- The heating element is completely sealed to protect from spills.
- 3.75 KW wafer plate elements with easy-to-clean flat surface.
- Thermostatic controlled plates

STANDARD OVEN

- Baffle above the element distributes heat flow to provide even cooking temperatures throughout the 5.3 KW oven. Splatter screen protects the element from spills.
- Chef depth oven interior accommodates standard 18" x 26" (457 x 660 mm) sheet pans front-to-back and side-by-side.
- Oven is 26½" w x 26" d x 14" h (673 x 660 x 356 mm)
- Heavy duty thermostat with temperature range from 150°F to 500°F (65°C to 260°C)
- Porcelainized sides, rear, deck and inner door liner.
- Side oven controls are protected from heat in an insulated side compartment
- Stamped inner door liner provides extra strength while improving heat retention.
- Splatter screen protects the element from spills.
- One chrome oven rack is included.

EXTERIOR FEATURES

- Stainless steel front, sides, backguard, shelf, landing ledge and kick plate.
- Welded and polished stainless steel seams.
- Large 4" (101 mm) stainless steel landing ledge
- 6" (152 mm) heavy duty legs with adjustable feet
- One year parts and labor warranty.

CONVECTION OVEN

- 5.3 KW convection oven with 1/2 hp blower motor cooks products quickly and evenly with less shrinkage.
- Convection oven interior dimensions 26-½" w 22-½" d x 14" h (673 x 572 x 356 mm).
- Three position switch for cooking or cool down. Fan shuts off automatically when door is open.
- Porcelainized sides, rear, deck and door lining for easy cleaning.
- Three chrome oven racks included.



MADE IN USA



1128 Sherborn Street | Corona, CA 92879 | 800.343.7790 | imperialrange.com | imperialsales@imperialrange.com

©2026 Imperial Commercial Cooking Equipment Imperial reserves the right to change specifications at any time without prior notice and without any obligation for past or future equipment purchases. Visit www.imperialrange.com for specification updates



ELECTRIC

SPEC SERIES 36" WAFER PLATE RANGES

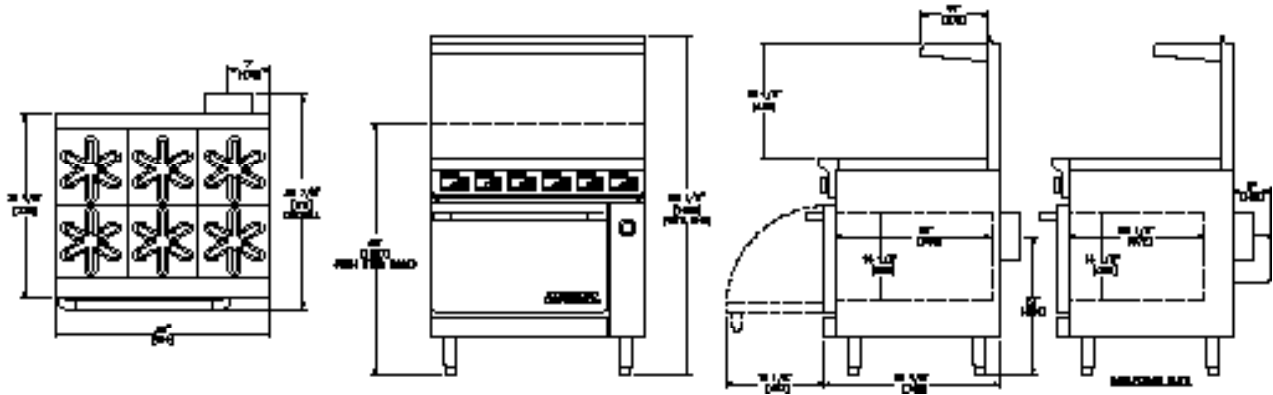

MODEL	PLATE ELEMENTS	SHIP WEIGHT (KG) LBS	DIMENSIONS	CRATED DIMENSIONS
IHR-6-EW	6	(204) 450	36" W x 35 7/8" D x 42" H (914 x 911 x 1067 mm)	38" W x 41" D x 38" H (965 x 1041 x 965 mm)

ELECTRICAL REQUIREMENTS

MODEL	TOTAL KW	VOLTS	PHASE	AMPS Box A	AMPS Box B
IHR-6-EW	27.8	208	3	32	55
		240	3	28	48
IHR-6-EW-C	28.7	208	3	32	60
		240	3	28	52
IHR-6-EW-XB	22.5	208	3	32	32
		240	3	28	28

OPTIONS AND ACCESSORIES

- 6" (152 mm) stainless steel stub back, in lieu of standard backguard
- 11" (279 mm) stainless steel stub back, in lieu of standard backguard
- Reinforcement channels for mounting cheesemelter or salamander
- Extra oven racks
- Griddle top
- 6" (152 mm) casters
- 480 volts, 3 phase

CLEARANCE REQUIREMENTS

For use only on non-combustible floors. Legs or casters are required for non-combustible floors; or 2" (51 mm) overhang is required when curb mounted. Provide 0" clearance from non-combustible surfaces and 6" (152 mm) from combustible surfaces.



MADE IN USA

Notes: Measurements in () are metric equivalents.

Contact Imperial about additional single phase options.

*Additional charge



1128 Sherborn Street | Corona, CA 92879 | 800.343.7790 | imperialrange.com | imperialsales@imperialrange.com

©2026 Imperial Commercial Cooking Equipment Imperial reserves the right to change specifications at any time without prior notice and without any obligation for past or future equipment purchases. Visit www.imperialrange.com for specification updates