



GAS

SPEC SERIES | TUBE FIRED FRYERS



IHR-F50

Model Numbers:
IHR-F2525
IHR-F-DS-75
IHR-F-DS

IHR-F50
IHR-F75



Robotic welding is precise, virtually eliminating leaks.

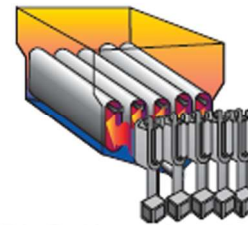

Tube fired burners have a large heat transfer area.

TUBE FIRED BURNERS

- High efficiency cast iron burners have a large heat transfer area.
- Tubes are constructed of heavy gauge metal with a built-in deflector system.
- 175,000 BTU (51 KW) total output.
- Millivolt temperature control circuit
- Snap acting electronic thermostat has a 200°F - 400°F (93°C - 204°C) temperature range that extends oil life and produces a uniformly cooked product.
- Fast recovery to desired temperature.
- Heats oil quickly producing a better tasting product with less oil absorption.
- 100% safety shut-off

STAINLESS STEEL FRYPOTS

- Frying area is 18" x 18" (457 x 457mm).
- Frypot tubes and sides are robotically welded stainless steel to virtually eliminate leaks.
- Fine mesh wire crumb screen is included.
- Recessed bottom facilitates draining, slants toward the drain.
- 1-1/4" (32 mm) full port drain valve empties frypot quickly and safely.
- Two large, nickel-plated fry baskets with vinyl coated, heat protective, handles are included.
- Basket hangers are stainless steel.

EXTERIOR FEATURES

- Stainless steel front, door, sides, basket hanger and frypot.
- Welded and polished stainless steel seams.
- Full heat shield protects control panel.
- Full bottom chassis provides structural support.
- Plate mounted 6" high (152 mm) heavy duty stainless steel legs or optional casters assure secure support.
- One year parts and labor warranty. Limited warranty on frypot, stainless steel frypot is five years pro-rated.

LARGE COOL ZONE

- Captures and holds particles out of the fry zone
- Reduces taste transfer



1128 Sherborn Street | Corona, CA 92879 | 800.343.7790 | imperialrange.com | imperialsales@imperialrange.com

© 2026 Imperial Commercial Cooking Equipment Imperial reserves the right to change specifications at any time without prior notice and without any obligation for past or future equipment purchases. Visit www.imperialrange.com for specification updates



GAS

SPEC SERIES | TUBED FIRED FRYERS

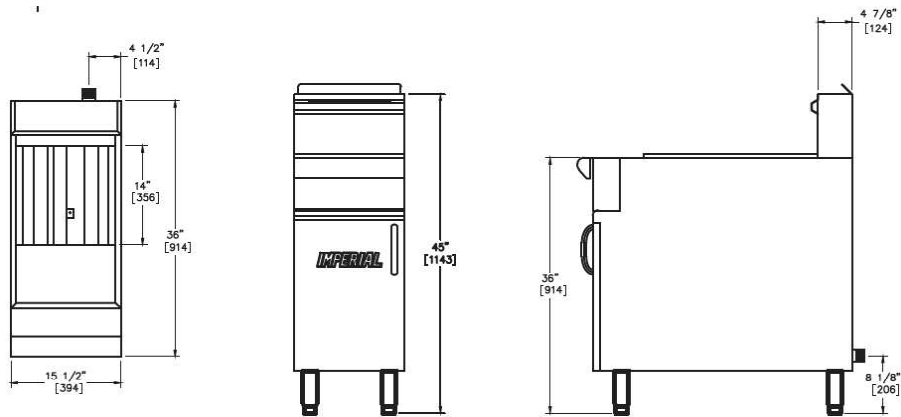

MODEL	OIL CAPACITY	GAS OUTPUT		#OF BURNERS	SHIP WEIGHT (KG) LBS
		BTU	(KW)		
IHR-F2525	25/25 (14/14 L)	140,000	(41)	4	(135) 299
IHR-F50	50 (27 L)	140,000	(41)	4	(129) 286
IHR-F75	75 (41 L)	175,000	(51)	5	(135) 298
IHR-F-DS	N/A	N/A	N/A	N/A	(86) 190
IHR-F-DS-75	N/A	N/A	N/A	N/A	(91) 200

MANIFOLD PRESSURE		MANIFOLD SIZE
NAT GAS	PROPANE	
4.0" W.C.	10.0" W.C.	1 1/4" (32MM)

Specify elevation, if over 2,000 ft.

OPTIONS AND ACCESSORIES

- Heavy duty stainless steel backguards
- Stainless steel common front landing ledge 54", 72", 90", 108" (1372, 1829, 2286, 2743 mm)
- Fryer drain station with storage cabinet
- Automatic basket lifts
- Computer controls
- Manual timer
- Extra fry baskets with vinyl coated handles
- Gas shut-off valve, 3/4" N.P.T.
- Quick disconnect and flexible gas hose, 3/4" or 1/4", N.P.T. connection
- 3/4" rear gas connection for single unit connection
- 1/4" rear gas connection for single unit connection
- Fryer Tip Brush
- Goofer Declogger Rod
- Sediment Scooper
- 6" (152 mm) casters

CLEARANCE REQUIREMENTS

For use only on non-combustible floors. Legs or casters are required for non-combustible floors; or 2" (51 mm) overhang is required when curb mounted. Provide 0" clearance from non-combustible surfaces and 8" (203 mm) from combustible surfaces.

MODEL	FRYER AREA	DIMENSIONS	CRATED DIMENSIONS
IHR-F2525	2 EA. 6 3/4" X 14" (171 X 356 MM)	15 1/2" W X 40 3/4" D X 46 1/2" H (394 X 1035 X 1181 MM)	18" W X 43" D X 35" H (457 X 1092 X 889 MM)
IHR-F50	14" X 14" (356 X 356 MM)	15 1/2" W X 40 3/4" D X 46 1/2" H (394 X 1035 X 1181 MM)	18" W X 43" D X 35" H (457 X 1092 X 889 MM)
IHR-F75	18" X 18" (457 X 457 MM)	19 1/2" W X 40 3/4" D X 46 1/2" H (495 X 1035 X 1181 MM)	23" W X 43" D X 35" H (584 X 1092 X 889 MM)
IHR-F-DS	N/A	15 1/2" W X 40 3/4" D X 46 1/2" H (394 X 1035 X 1181 MM)	18" W X 43" D X 35" H (457 X 1092 X 889 MM)
IHR-F-DS-75	N/A	19 1/2" W X 40 3/4" D X 46 1/2" H (495 X 1035 X 1181 MM)	23" W X 43" D X 35" H (584 X 1092 X 889 MM)

NOTES:

- "DS" specifies 4" (102 mm) deep top draining station with storage cabinet, no filter.
- Includes a 4" (102 mm) deep stainless steel drain pan
- Measurements in () are metric equivalents



MADE IN USA



1128 Sherborn Street | Corona, CA 92879 | 800.343.7790 | imperialrange.com | imperialsales@imperialrange.com

©2026 Imperial Commercial Cooking Equipment. Imperial reserves the right to change specifications at any time without prior notice and without any obligation for past or future equipment purchases. Visit www.imperialrange.com for specification updates