



# GAS SINGLE CONVECTION OVENS

**IMPERIAL**



## PCVG-1

Shown with optional casters

### MODEL NUMBERS

PCVG-1

PCVDG-1

## TURBO-FLOW SYSTEM

- This system assures even cooking throughout the entire oven.
- Standard and Bakery depth oven sizes available.
- Cooked or baked products have less shrinkage, more moisture and taste better.
- Creates an air flow pattern that simultaneously heats the inner and outer surfaces of the oven cavity.
- Recirculates hot air to maximize efficiency for energy savings.
- Fast temperature recovery.
- 2-speed 1/2 hp fan motor for high production cooking and delicate baking.
- 2-speed oven cool down feature.
- Standard and Bakery depth ovens are rated 11 KW.
- Porcelainized oven interior for easy cleaning and provides better browning.
- 2 interior oven lights are controlled by a momentary switch outside the oven.
- 10 rack positions for maximum versatility.
- 5 oven racks included.
- One hand opens and closes both doors simultaneously
- 50/50 doors swing open to 130°

## PROGRAMMABLE CONTROLS WITH COOK 'N HOLD FEATURE:

- Easy to program. Simply select the time, temperature, fan settings and hold mode - then preset buttons.
- Cook 'N Hold feature. Cooks at a higher temperature for browning. Automatically switches to a lower holding temperature.
- 24 hr. digital countdown timer with easy-to-read LED digital display.
- Cooking versatility.
- Fan option lets you choose modes:
  1. Fan on continuously
  2. Fan on when heat is on pulsed fan feature
- Displays °F or °C readings.

## MANUAL CONTROLS

- Independent time and temperature controls give you maximum versatility for general baking and roasting.
- 2-speed fan switch controls bake or roast

## THERMOSTATIC OVEN CONTROL

- Electronic temperature control: 150°F to 500°F (66° C to 260° C).

## ON - OFF SWITCH

- 60 minute manual timer
- Audible buzzer lets you know when the cooking cycle is complete.

**IMPERIAL**

1128 Sherborn Street | Corona, CA 92879 | 800.343.7790 | imperialrange.com | imperialsales@imperialrange.com

©2026 Imperial Commercial Cooking Equipment Imperial reserves the right to change specifications at any time without prior notice and without any obligation for past or future equipment purchases. Visit [www.imperialrange.com](http://www.imperialrange.com) for specification updates



# GAS SINGLE CONVECTION OVENS

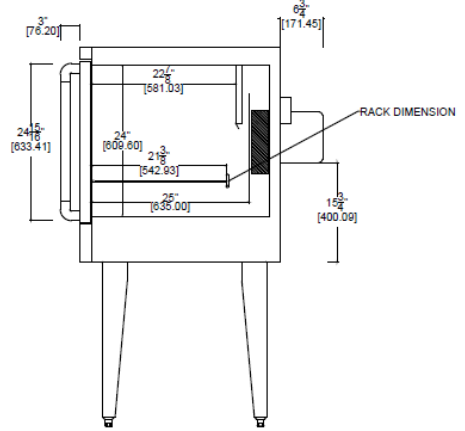
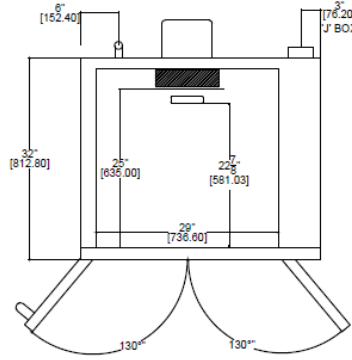
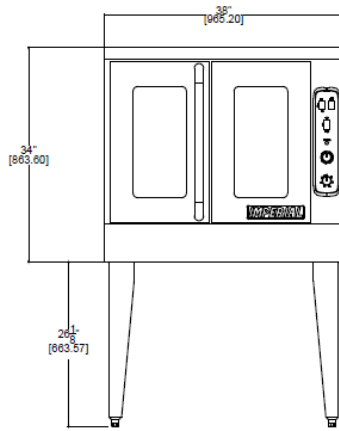

## GAS CONVECTION OVENS

MODEL	DESCRIPTION	DIMENSIONS	GAS OUTPUT BTU	GAS OUTPUT KW	SHIP WEIGHT KG	SHIP WEIGHT LBS
PCVG-1	SINGLE DECK, STANDARD DEPTH	38" W X 40-7/8" D X 64" H (965 X 1038 X 1526 MM)	70000	21 KW	236	521
PCVDG-1	SINGLE DECK, BAKERY DEPTH	38" W X 44-7/8" D X 64" H (965 X 1140 X 1526 MM)	80000	23 KW	277	611

## OPTIONS AND ACCESSORIES

- Cook and Hold computer controls
- Stainless steel back enclosure
- Direct connect vent
- Heavy duty casters, set of 4
- Stack kit with 6" (152) stainless steel legs
- Stainless steel solid doors
- Stainless steel bottom shelf and adjustable rack supports
- Stainless steel bottom shelf only for stand
- Extra oven racks
- 480 volt

## UTILITY REQUIREMENTS GAS MODELS

MODEL	VOLTAGE	PHASE	HERTZ	AMPS
PCVG-1, PCVDG-1	120	1	60/50	9

## CLEARANCE REQUIREMENTS

For use only on non-combustible floors with legs or casters; or 2 1/4" (57 mm) overhang is required when curb mounted. Provide 0" clearance from non-combustible side and rear walls. Provide 6" (152mm) minimum clearance from combustible side walls and 0" from combustible wall at rear.

Two speed motor - 1/2 HP, 1725/1140 RPM

## EXTERIOR

- Stainless steel exterior, except back. Reflects a quality, professional look for exhibition cooking.
- Welded and finished seams
- Stainless steel legs
- Easy to clean and maintain
- One year parts and labor warranty



**MADE IN USA**



1128 Sherborn Street | Corona, CA 92879 | 800.343.7790 | imperialrange.com | imperialsales@imperialrange.com

©2026 Imperial Commercial Cooking Equipment Imperial reserves the right to change specifications at any time without prior notice and without any obligation for past or future equipment purchases. Visit www.imperialrange.com for specification updates