



# DIRECT STEAM FULL JACKETED TILTING KETTLE

- KDLT-20F
- KDLT-30F
- KDLT-40F
- KDLT-60F

**OPERATION SHALL BE BY:**

Direct steam at a minimum of 5 PSI (34kPa) and a maximum of 30 PSI (207 kPa).



**OPTIONS & ACCESSORIES AT ADDITIONAL COST**

- |   |   |   |
|---|---|---|
| <input type="checkbox"/> 50 PSI (345kPa) high pressure operation for higher cooking temperature | <input type="checkbox"/> Triple basket assembly (TBA-)                        | <input type="checkbox"/> Graduated measuring strip (CMS-) |
| <input type="checkbox"/> 2" (50 mm) draw off-valve (TVT-2) with perforated strainer (TPS-)      | <input type="checkbox"/> Steam control assembly (STA-2)                       | <input type="checkbox"/> Strainer hook (SH)               |
| <input type="checkbox"/> 3" (76 mm) draw off-valve (TVT-3) with perforated strainer (TPS-)      | <input type="checkbox"/> Single pantry faucet with swing spout (SF-18)        | <input type="checkbox"/> Pour lip strainer (TKS-)         |
| <input type="checkbox"/> Spring assist hinged cover for 20, 30 or 40 gallon models (CH-)        | <input type="checkbox"/> Double pantry faucet with swing spout (DF-18)        | <input type="checkbox"/> Pan carrier (PC-4)               |
| <input type="checkbox"/> Etched gallon markings (GM-)   | <input type="checkbox"/> Solid stainless steel disc for draw-off valve (TSS-) | <input type="checkbox"/> Kettle heat shield (KHS-)        |
| <input type="checkbox"/> Etched litre markings(LM-)   |   |   |
| <input type="checkbox"/> One piece lift off cover (C-)  |   |   |

**STANDARD CONSTRUCTION SPECIFICATIONS**

Shall be a Southbend Steam model KDLT-20F, KDLT-30F, KDLT-40F, KDLT-60F, KDLT-80F, or KDLT-100F, direct steam connected full jacketed leg tilting kettle.

A double wall kettle interior shall form a steam jacket around the kettle.

The bottom of the kettle shall be of hemispherical design for superior heat circulation.

The mounting frame of stainless steel pipe shall support the kettle and tilt console and conceal the steam piping, house the steam control valve and tilt mechanism.

Each leg shall be fitted with a 4 hole adjustable flanged foot for securing to the floor.

The tilt mechanism shall permit the kettle to tilt forward a full 90° for complete emptying.

The tilting mechanism shall be self-locking for positive stop action.

Construction shall be all welded #4 finish stainless steel type 304.

The kettle liner shall be standard 316 for high acid content cooking.

Faucet bracket standard.



Approval Notes: \_\_\_\_\_

\_\_\_\_\_

KDLT-F-SB

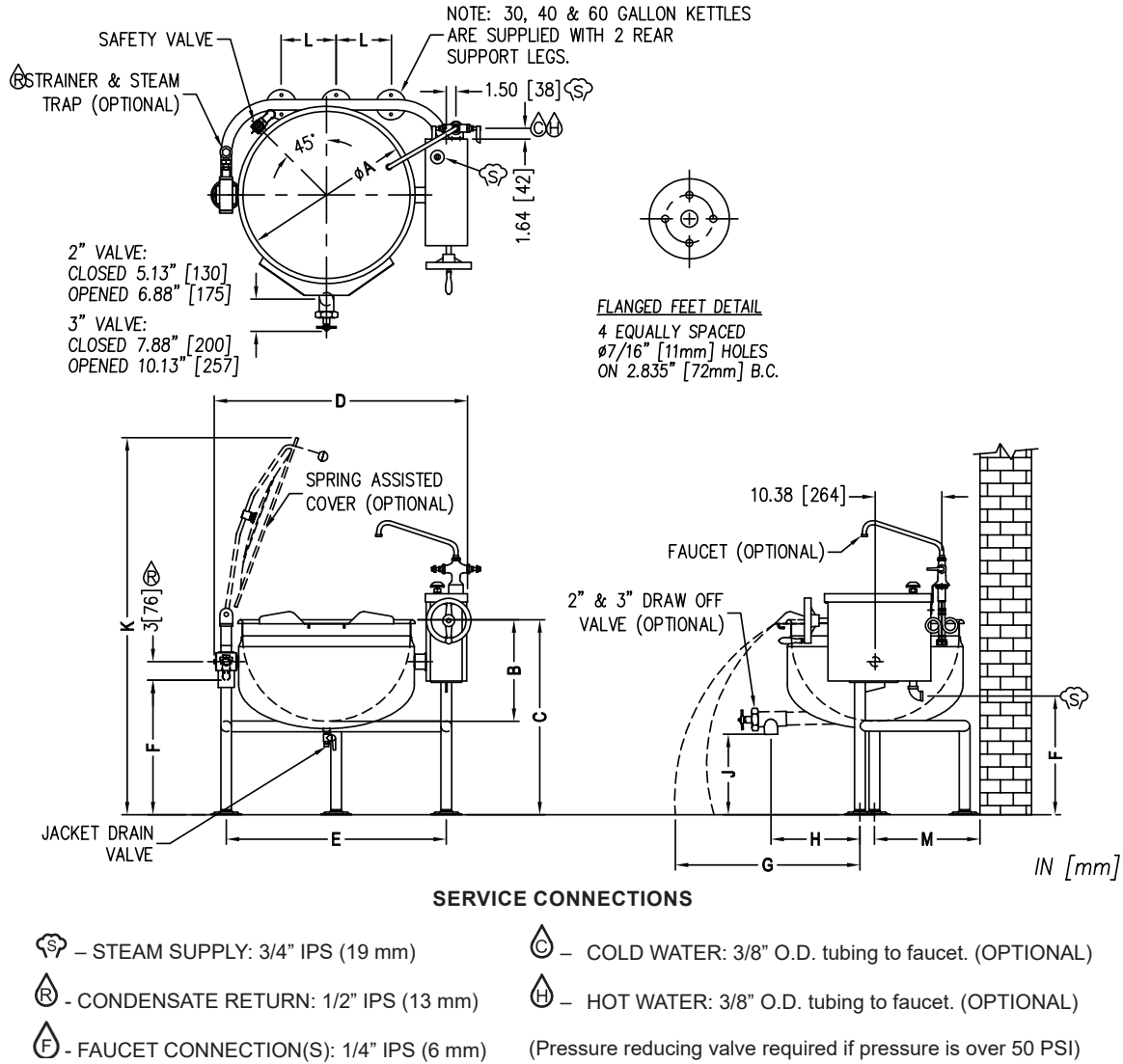

**DIMENSIONS**

MODEL	CAPACITY	UNITS	A	B	C	D	E	F	G	H(2")	H(3")	J(2")	J(3")	K	L	M
KDLT-20F	20 gallons (76 liters)	in (mm)	26" (660)	15.75" (400)	30.25" (768)	39.75" (1010)	33.5" (850)	20.25" (514)	28.63" (727)	13" (330)	15.25" (387)	12.5" (318)	12" (305)	63" (1600)	N/A	16.38" (416)
KDLT-30F	30 gallons (114 liters)	in (mm)	29.5" (749)	17.5" (445)	32" (813)	43.25" (1100)	37" (940)	21.5" (546)	30.13" (765)	15.5" (394)	15.5" (394)	14.5" (368)	14" (356)	68.88" (1749)	9.5" (241)	18.38" (467)
KDLT-40F	40 gallons (152 liters)	in (mm)	33" (840)	19.25" (489)	33.75" (857)	46.75" (1185)	40.5" (1030)	20" (508)	32.63" (828)	14.5" (368)	16.25" (413)	12.5" (318)	12" (305)	73.25" (1861)	11" (279)	19.88" (505)
KDLT-60F	60 gallons (227 liters)	in (mm)	35.5" (902)	20.5" (521)	33" (838)	49.25" (1251)	43" (1092)	21" (533)	39.25" (997)	18" (457)	20.25" (514)	10.5" (267)	10" (254)	76.25" (1937)	12.5" (318)	21.5" (546)

**SPECIFICATIONS**

MODEL	SHIPPING WEIGHT	MINIMUM CLEARANCE		MODEL	SHIPPING WEIGHT	MINIMUM CLEARANCE	
KDLT-20F	320 lbs. [145 kg]	SIDES	0 [0]	KDLT-40F	396 lbs. [180 kg]	SIDES	0 [0]
KDLT-30F	350 lbs. [159 kg]		BACK	0 [0]	KDLT-60F		439 lbs. [299 kg]

**INTENDED FOR COMMERCIAL USE ONLY.  
NOT FOR HOUSEHOLD USE.**

