



# DIRECT STEAM TWIN CONSOLE TILTING KETTLE



- KDLT-20TC
- KDLT-30TC
- KDLT-40TC
- KDLT-60TC
- KDLT-80TC
- KDLT-100TC

**OPERATION SHALL BE BY:**

Direct steam at a minimum of 5 PSI (34kPa) and a maximum of 35 PSI (241kPa).

**OPTIONS & ACCESSORIES AT ADDITIONAL COST**

- |  |  |  |
|--|--|--|
| <input type="checkbox"/> 50 psi (345 kPa) high pressure operation for higher cooking temperature (HP-50) | <input type="checkbox"/> Solid disc strainer for draw-off valve (TSS-)                                       | <input type="checkbox"/> Draw-off valve hose kit with 8' hose (DVHK-)  |
| <input type="checkbox"/> 2" (50 mm) draw-off valve (TVT-2)   | <input type="checkbox"/> Perforated strainer for draw-off valve (TPS-)                                       | <input type="checkbox"/> Single pantry kettle filler (SP-KF)           |
| <input type="checkbox"/> 3" (76 mm) draw-off valve (TVT-3)   | <input type="checkbox"/> Steam trap assembly consisting of steam trap, line strainer and check valve (STA-2) | <input type="checkbox"/> Double pantry kettle filler (DP-KF)           |
| <input type="checkbox"/> Spring assist hinged stainless steel cover (CH-)                                | <input type="checkbox"/> Lift off kettle cover (C-)  | <input type="checkbox"/> Single pantry faucet with swing spout (SF-18) |
| <input type="checkbox"/> Etched gallon markings (GM-)  | <input type="checkbox"/> Strainer hook (SH-)   | <input type="checkbox"/> Double pantry faucet with swing spout (DF-18) |
| <input type="checkbox"/> Etched liter markings (LM-)   | <input type="checkbox"/> Contoured measuring strip (CMS-)  | <input type="checkbox"/> Kettle heat shield (KHS-)                     |
| <input type="checkbox"/> Correctional package  | <input type="checkbox"/> Pour lip strainer (TKS-)  |  |
| <input type="checkbox"/> Quick chill system (QCS-1)  | <input type="checkbox"/> Pressure reducing valve (PRV-2)   |  |
| <input type="checkbox"/> Triple basket assembly (TBA-)   | <input type="checkbox"/> Pan Carrier (PC-4)  |  |

**STANDARD CONSTRUCTION SPECIFICATIONS**

Shall be a Southbend Steam model KDLT-20TC, KDLT-30TC, KDLT-40TC, KDLT-60TC, KDLT-80TC or KDLT-100TC, direct steam connected, 2/3 jacketed, twin console kettle.

A double wall kettle interior shall form a steam jacket around the lower 2/3 of the kettle.

The bottom of the kettle shall be of hemispherical design for superior heat circulation.

The kettle liner shall be standard with type 316 stainless steel for high acid content cooking.

Each supporting console shall have two legs for bolting unit to the floor and will conceal the steam and optional quick chill plumbing.

The tilt mechanism shall permit the kettle to tilt forward part 90° for complete emptying and be self-locking for positive stop action.

Construction shall be all welded #4 finish, stainless steel, type 304.

A steam control valve shall be provided and mounted in the right console.



Approval Notes: \_\_\_\_\_

\_\_\_\_\_

KDLT-TC-SB

## QUICK CHILLED MODEL

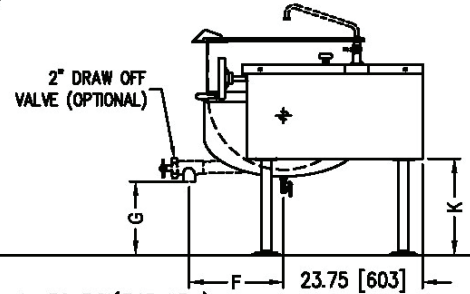
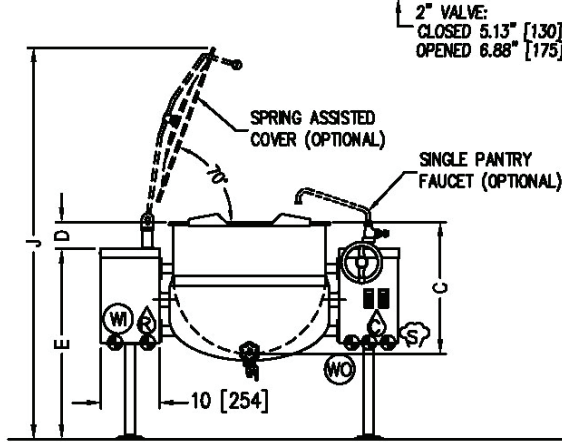
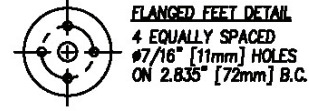
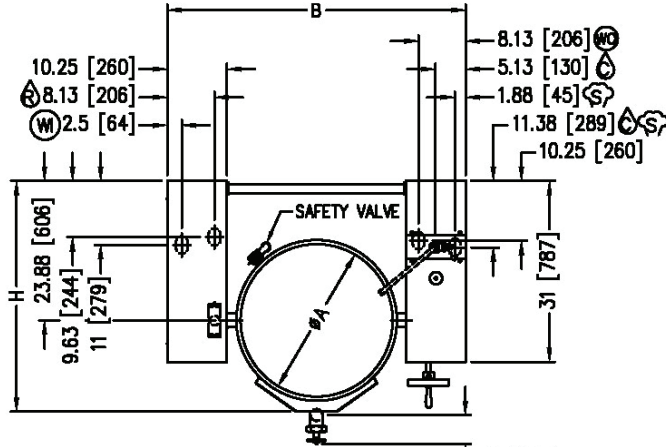

IN [mm]  
7242R1

\* Pressure reducing valve is required if incoming pressure exceeds 50 PSI(345 kPa).

### SERVICE CONNECTIONS

- STEAM SUPPLY: 3/4" IPS (19 mm)
- CONDENSATE RETURN: 1/2" IPS (13 mm)
- COLD WATER: 3/8" IPS (10 mm) O.D. tubing to faucet (optional)
- COLD WATER IN: 1/2" IPS (13 mm) for quick chilled system
- COLD WATER OUT: 1/2" IPS (13 mm) for quick chilled system

### DIMENSIONS

MODEL	CAPACITY	UNITS	A	B	C	D	E	F	G	H	J	K
KDLT-20TC	20 gallons (76 liters)	in (mm)	21" (533)	46" (1168)	18" (460)	2.75" (70)	32.5" (82.6)	14.25" (362)	15.39" (390)	36.88" (937)	60.38" (1533)	16.5" (419)
KDLT-30TC	30 gallons (114 liters)	in (mm)	24" (610)	49" (1245)	20" (508)	3.25" (82)	32.5" (826)	15.38" (391)	13.88" (352)	38.63" (981)	63.5" (613)	16.5" (419)
KDLT-40TC	40 gallons (152 liters)	in (mm)	26" (660)	51.13" (1298)	22.5" (570)	4.63" (117)	32.5" (826)	16.13" (410)	12.5" (318)	39.5" (1003)	66.88" (1699)	16.5" (419)
KDLT-60TC	60 gallons (227 liters)	in (mm)	29.5" (750)	54.38" (1381)	26" (660)	6.63" (168)	35.5" (902)	17.63" (448)	14" (356)	41.13" (1045)	75" (1905)	19.5" (495)
KDLT-80TC	80 gallons (303 liters)	in (mm)	33" (840)	57.88" (1470)	28" (711)	6.75" (171)	38.25" (972)	19.38" (492)	14.88" (378)	43.25" (1099)	81" (2057)	22.25" (565)
KDLT-100TC	100 gallons (379 liters)	in (mm)	35.5" (902)	60.25" (1530)	30" (762)	6.63" (168)	40.5" (1092)	20.12" (511)	15" (381)	44.63" (1133)	85.38" (2169)	24.5" (622)

**INTENDED FOR COMMERCIAL USE ONLY.  
NOT FOR HOUSEHOLD USE.**

