



# GAS STEAM KETTLE STATIONARY



- KSLG-80
- KSLG-100

**OPERATION SHALL BE BY:**

- Natural Gas
- L.P. Gas

For operation on 115 VAC, 1 phase 50/60 Hz, A.S.M.E. code stamped for operation up to 35 psi (241 kPa).

The steam kettle temperature ranges shall be between 165°F to 265°F (74°C to 130°C).

**OPTIONS & ACCESSORIES AT ADDITIONAL COST**

- |   |   |   |
|---|---|---|
| <input type="checkbox"/> 220-240 VAC operation (specify voltage) (GKVS-1)           | <input type="checkbox"/> Correctional Package                         | <input type="checkbox"/> Stainless steel tri basket, (TBA-)   |
| <input type="checkbox"/> 3" (76 mm) draw-off valve with perforated strainer (TVS-3) | <input type="checkbox"/> Single pantry faucet with swing spout, SF-12 | <input type="checkbox"/> Solid disc for draw-off valve (TSS-) |
| <input type="checkbox"/> Etched gallon markings (GM-)                               | <input type="checkbox"/> Double pantry faucet with swing spout, DF-12 | <input type="checkbox"/> Graduated measuring strip (CMS-)     |
| <input type="checkbox"/> Etched liter markings (LM-)                                | <input type="checkbox"/> Single pantry kettle filler (SP-KF-GK)       | <input type="checkbox"/> Strainer hook (SH-)                  |
|   | <input type="checkbox"/> Double pantry kettle filler (DP-KF-GK)       | <input type="checkbox"/> Draw-off valve hose kit (DVHK-)      |

**STANDARD CONSTRUCTION SPECIFICATIONS**

Shall be a Southbend Steam model KSLG-80E or KSLG-100E, gas fired, self-contained, fully insulated steam jacketed kettle, ASME Code stamped, National Board Registered, AGA and CGA design certified, NSF approved.

The unit comes standard with a spring assisted cover.

The kettle shall be constructed with an exterior of type 304 stainless steel, #4 sanitary finish and four 6" stainless steel adjustable legs.

The interior kettle liner shall be a one piece welded construction made with type 316 stainless steel with #4 sanitary finish, 2/3 jacketed and shall be furnished with a 2" tangent draw off valve with strainer as standard.

The recessed control panel is located on the front side of the unit in full view of the operator and is easy to use.

Standard controls include electronic ignition, direct immersion thermostat, water sight glass, cooking light, pressure gauge and low water indicator light.

Safety features shall include a low water cut off, pressure relief valve, pressure switch and a safety gas shutoff valve.

A double wall kettle interior shall form a steam jacket around the lower 2/3 of the kettle. The bottom of the kettle shall be of hemispherical design for superior heat circulation.

Convenience features shall include 2" (50 mm) sanitary draw-off valve with a heat resistant handle.

Faucet bracket included.



Approval Notes: \_\_\_\_\_

\_\_\_\_\_

KSLG80-100

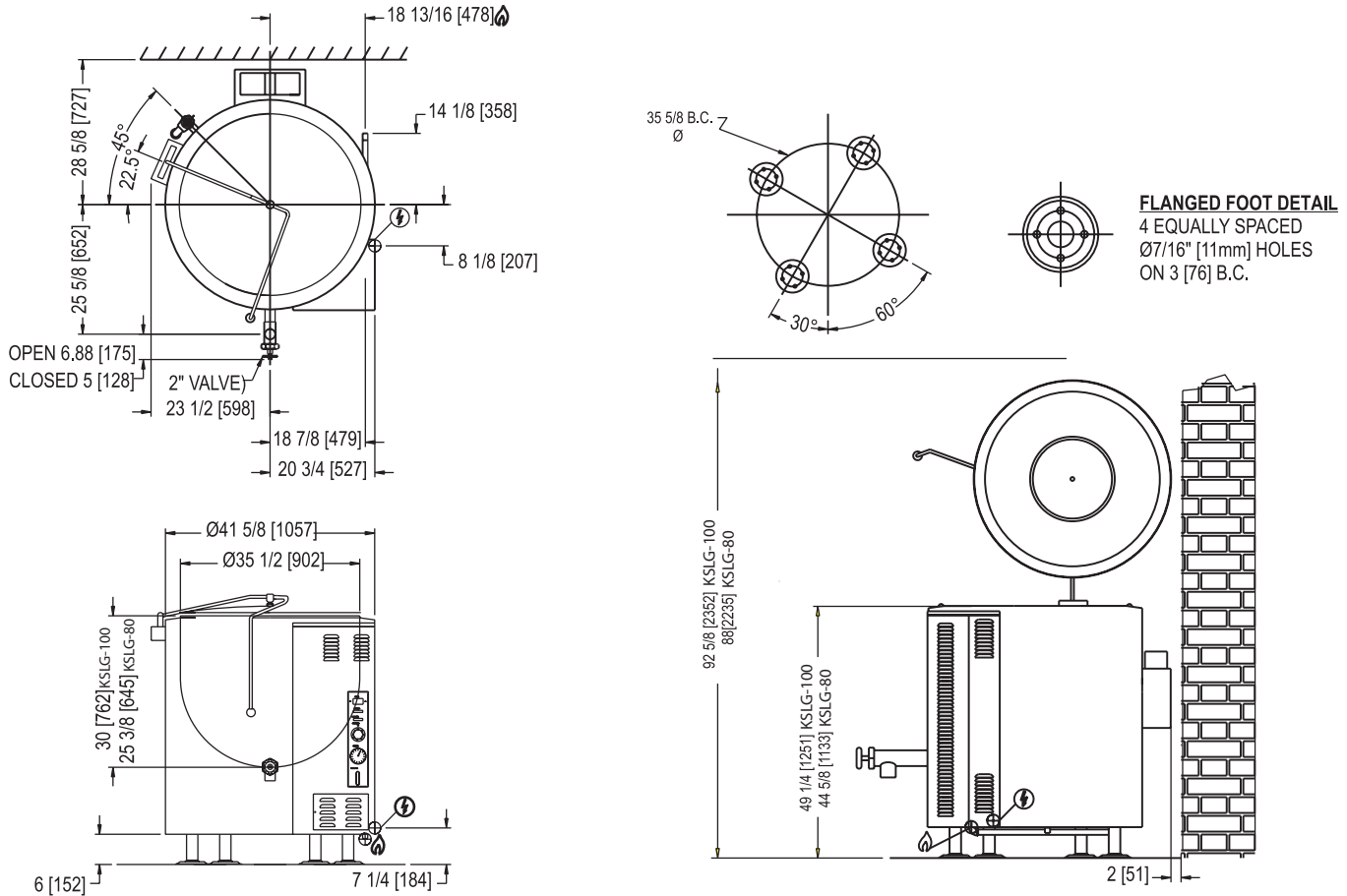

DIMENSIONS ARE IN INCHES [MM]

**SERVICE CONNECTIONS**

- Supply gas through 3/4" pipe. A gas shut-off valve must be installed in supply piping convenient and adjacent to appliance
- Unless other wise specified, Field Wire Electrical Connection to be 120 Volts, 60 Hertz, single phase with grounding wire. Unit furnished with 6' cord and 3 prong plug. Total maximum amps 2.0.

**GAS CHARACTERISTICS**

MODEL	GAS SUPPLY		
	BTU/HR.	kw/HR.	SUPPLY PIPE PRESSURE (W.C.)
KSLG-80	150,000	44.0	Natural 6"-14" (152-355 mm)      Propane 11"-14" (279-355 mm)
KSLG-100	150,000	44.0	

\* For use on non-combustible floors only.

**SPECIFICATIONS**

MODEL	CAPACITY	
KSLG-80	80 Gallon	303 Liter
KSLG-100	100 Gallon	379 Liter

MODEL	SHIPPING WEIGHT	MINIMUM CLEARANCE *	
KSLG-80	950 lbs. [430 kg]	Side Back	6" [152 mm] 2" [51 mm]
KSLG-100	1100 lbs. [498 kg]		

**INTENDED FOR COMMERCIAL USE ONLY.  
NOT FOR HOUSEHOLD USE.**

