

Spec sheet

# Invoq | Bake 16 - 400x600 EN

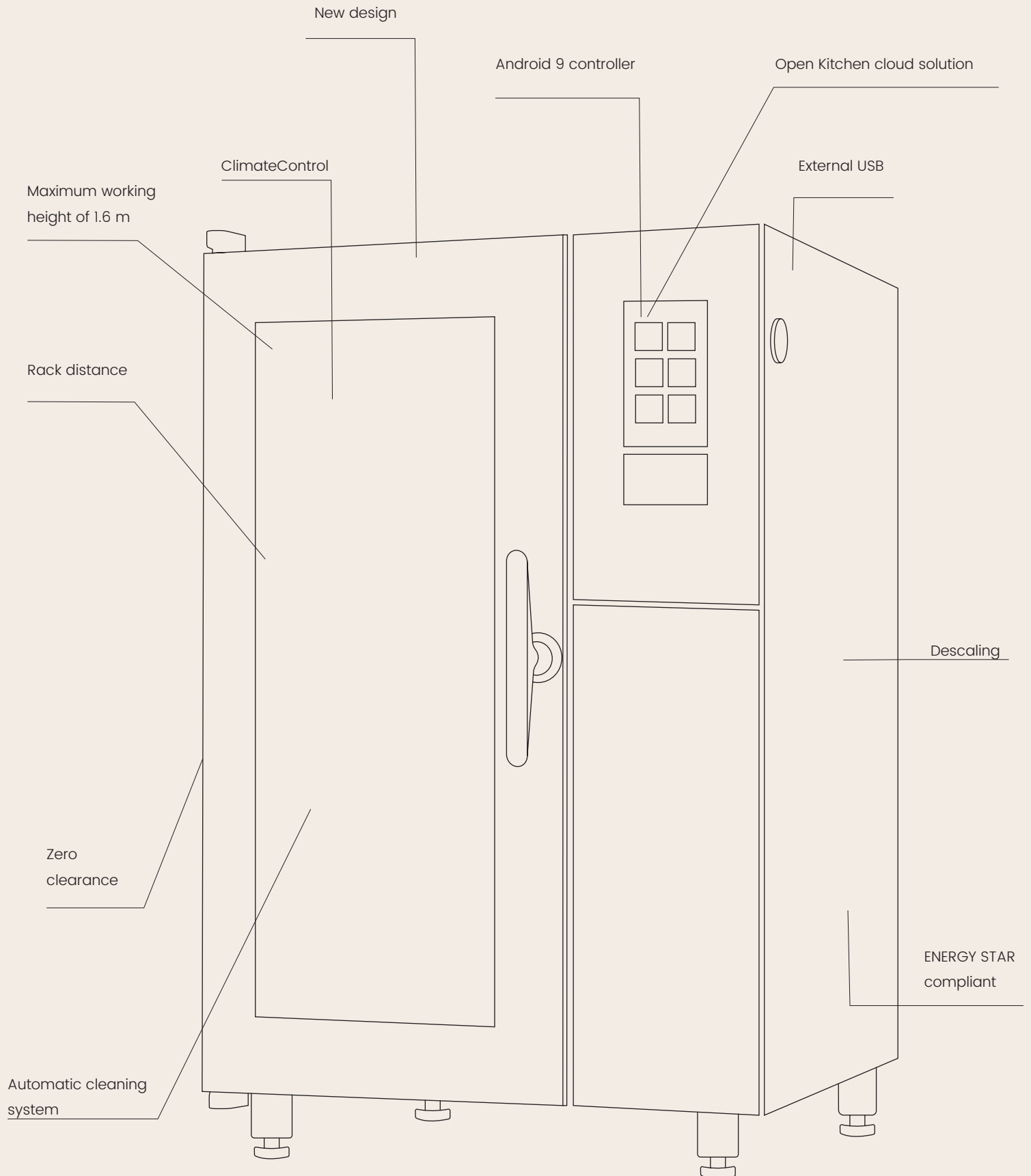



# A whole new oven experience

The Invoq Bake is the perfect kitchen appliance, where all the latest technologies have been made simple for you to use.

Increased rack spacing allows the circulating airflow to create perfect uniformity across the rack. You get an even and consistent bake covering all aspects of the baking kitchen from beautifully crusty breads to perfectly baked products from frozen and even delicately baked desserts. The roll-in system gives you safe and efficient operation for increased productivity, as well as good ergonomics with a max working height of 1.6 m.

The humidity creation and the automated cleaning system are controlled to utilise a minimum amount of energy and water without ever compromising quality results.

## Intelligence at the tip of your finger...

### ClimateControl

ClimateControl ensures best-in-class performance, controlling the air, heat and humidity levels. It optimises processes and even shortens baking times. The result is consistent uniformity and predictably high quality.

### CareCycle

Select between seven different cycles from Light to Intense, Turbo or Eco. The Invoq oven guides you through the process and suggests the optimal cleaning program and required amount of cleaning tablets for the desired cycle. This ensures that the ratio of detergent to water is always correct and you avoid overconsumption.

### CAPACITY

- 400x600 EN
- 16 trays with 80 mm runners or 14 trays with 95 mm runners
- Maximum working height of 1.6 m
- 4.5 kg maximum food load per tray
- 72 kg maximum food load per oven

### QSR

QSR, Quick Select Recipes, is a tailored, smart interface giving you peace of mind knowing that any member of your team will perform to the highest standards with the same consistency, less waste and maximum throughput. This saves time and prevents errors.

### SmartBaker

SmartBaker helps you learn from the oven to develop your signature style. You select type of products and the baking method, and SmartBaker will automatically guide you to a great result. Afterwards, you can save and, if necessary, edit the process.

# Electricity

## Dimensions & weight



Dimensions excl. handle (HxWxD) [mm]	1730 x 917 x 841
Dimensions incl. handle (HxWxD) [mm]	1730 x 917 x 923
Shipping dimensions (HxWxD) [mm]	2050 x 1000 x 1200
Net weight [kg]	274
Shipping weight [kg]	294
Clearance (left, back, right) [mm]	0 x 0 x 40
Maximum working height [mm] basic stand	1615

## Power requirements



Power consumption [kW]	38.2
Convection output [kW]	36
Grid supply frequency [Hz]	50/60*
<b>Voltage 400 V 3PN AC</b>	
Pre-fuse [A]	63
RCD model	B/F
<b>Voltage 415 V 3 PN AC</b>	
Pre-fuse [A]	63
RCD model	B/F
<b>Voltage 440 V 3 PN AC</b>	
Pre-fuse [A]	63
RCD model	B/F

## Water requirements



Water connection [inches]	3/4
Drain [mm]	Ø50
Water pressure (min-max) [bar]	1-6
Water flow [l/m]	5.5

## Heat emission



Latent heat load [kW]	1.11
Sensible heat output [kW]	2.49

## Noise emission



Noise level without hood system [dB(A)]	< 65
Noise level with hood system [dB(A)]	< 65

## IP classification



IP class	IPX5
----------	------

## Data



Wi-Fi module	IEEE 802.11 b/g/n
LAN	RJ45

\*The oven is built from factory for either 50 Hz or 60 Hz grid supply. Further technical information can be found in the installation manual.

- A Drain outlet
- B Air outlet (drain)
- C Air intake
- F Ethernet connection
- G Electrical connection
- W Water inlet (HydroShield water filter or reverse osmosis)
- X Water inlet

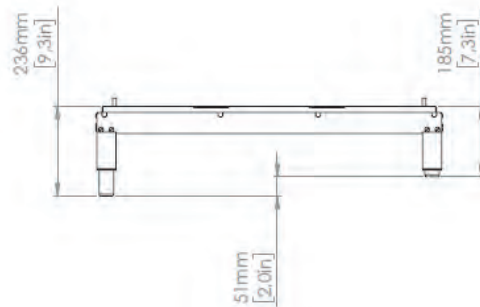
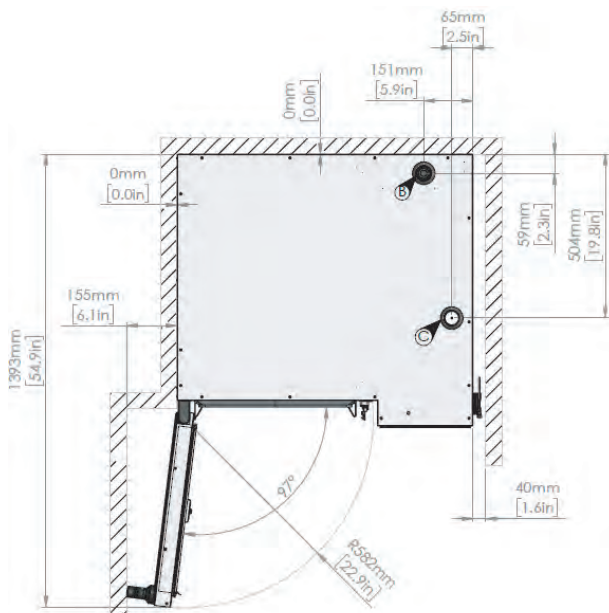

# Gas

## Dimensions & weight



Dimensions excl. handle (HxWxD) [mm]	1730 x 917 x 841
Dimensions incl. handle (HxWxD) [mm]	1730 x 917 x 923
Shipping dimensions (HxWxD) [mm]	2050 x 1000 x 1200
Net weight [kg]	
Shipping weight [kg]	
Clearance (left, back, right) [mm]	0 x 0 x 40
Maximum working height [mm] basic stand	1615

## Power requirements

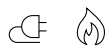

Gas consumption [kW]	40
Convection thermal load [kW]	40
Grid supply frequency [Hz]	50/60*
<b>Voltage 230 V 1 PN AC</b>	
Power consumption [kW]	1.5
Pre-fuse [A]	10
RCD model	B/F
Available gas types [natural/LPG]	G20, G25 / G30, G31

## Water requirements



Water connection [inches]	3/4
Drain [mm]	Ø50
Water pressure (min-max) [bar]	1-6
Water flow [l/m]	5.5

## Heat emission



Latent heat load [kW]	
Sensible heat output [kW]	

## Noise emission



Noise level without hood system [dB(A)]	
---	--

## IP classification



IP class	IPX5
----------	------

## Data



Wi-Fi module	IEEE 802.11 b/g/n
LAN	RJ45

\*The oven is built from factory for either 50 Hz or 60 Hz grid supply. Further technical information can be found in the installation manual.

- A Drain outlet
- B Air outlet (drain)
- C Air intake
- D N/A
- E Gas heat exchanger outlet
- F Ethernet connection
- H Gas connection
- W Water inlet (HydroShield water filter or reverse osmosis)
- X Water inlet

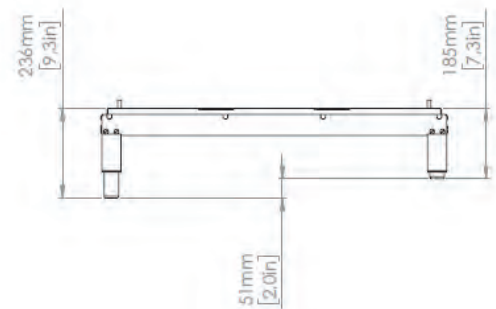
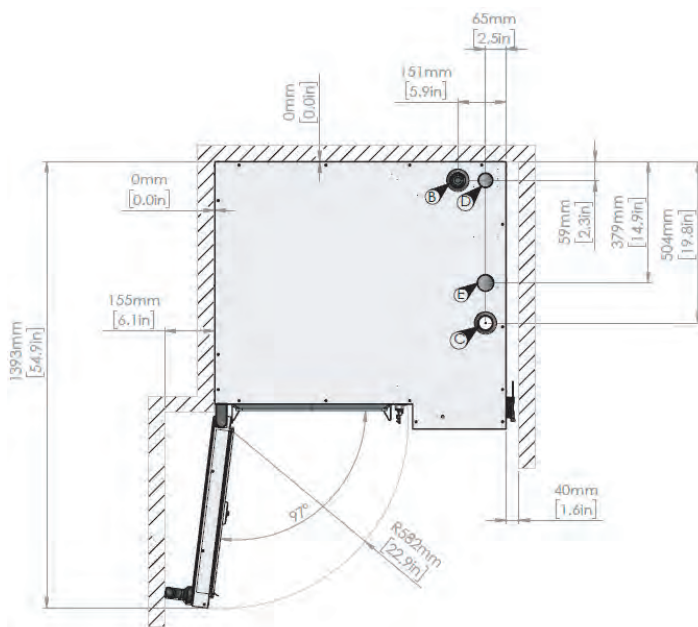

# Features

## Intelligence

ClimateControl	Optimal baking environment through control of air, heat, pressure and humidity levels. Reversible fan adjustable with 9 steps (20-100%). Humidity correction accurate to 1/10 of a second.
CareCycle	Fully automatic, recirculating tablet-based cleaning system. System guidance to appropriate cleaning program and required amount of detergent. Organiser to schedule a carefree overnight clean. Automatic rinse after interrupted cleaning cycle.
MenuPlanner	Up to 10 integrated timers for notifications. Software to input and group recipes with drag and drop functionality. Automatic alert to request staggering of loading when grouping up to three specific recipes.
BakeTimeCorrection (BTC)	Intelligent sensors detecting unexpected changes in temperature and compensating accordingly.
SmartBaker	Intelligent baking automation selecting the optimal baking settings.
Humidity control, CombiSense	Percentage-based automatic humidity system for high-temperature baking obtaining a shiny, crisp and crunchy finish while maintaining a moist centre.
Humidity control, CombiSpeed	Level-controlled humidity injection for improving low-temperature cooking optimising tenderisation and yield of larger products. 10 different humidity levels.
QSR	QSR, Quick Select Recipes, is a tailored smart user interface allowing recipes as favourites on the home screen. 9 thumbnail recipes per page - up to 9 pages for a total of 81 recipes. Option of locked down user interface to prevent manual operation.
Connectivity, Open Kitchen	Cloud solution for menu management, recipe distribution, preventive maintenance, real-time overview of fleet, food safety documentation and consumption data overview.
Power failure	Automatic restart after power failure allowed up to 30 minutes to ensure finalisation of running programs. Automatic rinse after interrupted cleaning process for safe baking. User notification of failure occurred and documents via HACCP.

## Operation

Convection, temperature range	30-300°C / 85-572°F 300°C / 572°F possible for 15 minutes, then reducing to 250°C / 480°F for continued run in manual mode.
CombiSense, temperature range	30-250°C / 85-480°F Accurate automatic humidity adjustment.
CombiSpeed, temperature range	30-250°C / 85-480°F CombiSpeed: Power steam adjustable in 10 levels for reduced cooking time and tenderizing products.
Cool down	Rapid cool down function with possibility for doing it with the door open or by use of water.
Proving	Humidity regulated proving function for optimum proving of baked products

## Operation

InjectionSteam	In steaming mode, steam is generated by injecting water directly on to the heating elements and circulating it with the fan creating fast and efficient steam.
Steam on demand	Push and hold in manual mode or push and select between 1-30 seconds.
Steam on demand in recipes	Programmable steam on demand between 1-30 seconds. Pause can be added between steps for optimal crust.
Recipes	<p>The oven can hold 1,500 recipes.</p> <p>Each recipe can hold up to 15 different steps.</p> <p>A set of preset recipes are installed on the oven from factory.</p> <p>Recipes can be grouped, e.g. bakery products, Italian cuisine.</p> <p>Choose from icons or photos, available from a preinstalled library, or upload own images.</p> <p>Simple upload or transfer between Invoq ovens via USB or the cloud solution.</p>

## Safety

Fan wheel brake	Rapid fan stop.
Overheat protection	Overheating protection for convection heat and steam generator.
Contact temperature	Maximum contact temperature of oven door 70°C.
3-pane glass door	Swivelling glass panes with built-in ventilation and energy-optimised coating.
Tablet cleaner and descaler	Tablet-based environmentally conscious cleaner and descaling chemicals for improved work safety.
HACCP	<p>HACCP files are automatically stored for 60 days and can be downloaded in PDF format to ensure food safety documentation. Stored on the oven when not connected.</p> <p>HACCP data includes production time, production duration, preparation temperature and core temperature.</p>
Maximum rack height	Maximum working height of 1.6 m.
Display lock	Ensuring no interruption with operation when cleaning the surface.
IP protection	Protection class IPX5 protecting against water jets from all directions.
Door handle	Two-step safety handle as standard.
Cavity	DIN 1.4301 steel with seamless welding and rounded corners for optimal airflow and cleaning.

## Network

USB	Integrated USB interface for software, recipe and HACCP handling.
LAN	Ethernet interface for wired connectivity to Open Kitchen.
Wi-Fi	WLAN upgrade for wireless connectivity to Open Kitchen.
Connectivity	Open Kitchen cloud-based system enabling management of oven fleet and general facility management.

## Care

CareCycle	Fully automatic, recirculating tablet-based cleaning system with 7 cycles from Light to Intense, Turbo or Eco. Pressure-dependent system. Turbo cleaning in just 15 minutes. System guidance to appropriate cleaning program and required amount of detergent. Organiser to schedule a carefree overnight clean. Automatic rinse after interrupted cleaning cycle ensuring no chemical residue left in the chamber.
CareCycle Clean tablets	Phosphate-free formula of the detergent for an eco-conscious choice
CareCycle Descale tablets	Descaling of boiler unit for proper cleaning of hard water deposits.
HydroShield	Use carbon filtered water removing lime and gypsum.
3-pane glass door	Swivelling glass panes for easy cleaning.
Hand shower	Hand shower can be an add-on to be located on the side, with separate closing mechanism. The external hand shower is designed with focus on ergonomics and work environment.
External	Easy external clean due to stainless steel and glass surfaces and IPX5 protection.
Connectivity	Monitoring and consumption overview via the Open Kitchen cloud solution.

## Comfort

Time format	Adjustable in 24-hour format or am/pm.
Timer start	Customisable automatic timer starts. Allowing the oven to start and/or preheat unsupervised.
Timer modes	HH:MM – MM:SS – continuous time
Display	Digital temperature display adjustable in °C or °F, display of target and actual values. 1 or 2 fan wheels. Reversible fan ensuring uniform results. Optimum distribution of air and steam in oven chamber.
Fan speed	Adjustable fan with 9 steps (20–100%); low fan speed – ideal for light/delicate products The fan can be set manually in convection, steaming and regeneration mode. In all other modes, the fan function is set automatically.
Lighting	LED lighting from the door with high illumination of the oven chamber. Energy saving and long life.
Touch display	Fast reacting and intuitive touch display for smooth and easy operation.
User interface	Capacitive 7" TFT colour touch screen with super wide view for optimal viewing angles. Simple and intuitive operation by self explanatory symbols and guidance eases the operation like a smartphone, operated by Android 9. Compatible with Middleby UI for multi devices with same control.
Languages	27 languages preset for operation and trouble shooting.
Baking methods	7 operating modes and/or 5 baking modes.
Supervision access	View or change the operating mode.
Customisation	Customise the home screen to allow easier access to favourites, cleaning and MenuPlanner removing the risk of operator errors. Customise notes with alarms to guide staff. Incorporate guidelines to recipes for optimal usage and elimination of errors.

## Installation, maintenance & environment

Start widget	Correct and stress-free installation incl. location (sea level) customisation.
Service widget	Correct and easy maintenance incl service diagnosis and self-test functionality.
Fitting	Left- or right-hinged door for optimal ergonomics and kitchen design.
Service access	Easy service access from one side of the oven only.
Water filtration	HydroShield water treatment is recommended for optimal operation. User notification by oven for replacement.
Connectivity	Remote diagnosis and updates with Open Kitchen.
Warranty	Standard warranty or extended according to purchase agreement with distributor.
Maintenance	Regular maintenance is recommended according to the manufacturer's guideline by trained service partners
Energy efficiency	Tested in accordance with ENERGY STAR.
Ambient temperature	Maximum 50°C ambient operation temperature.

## Options

	Item number
Right-hinged door 16 EN	-
Fat Separation System I/I GN + EN (factory-built)	104853
Condensation hood (electric oven)	108113
Marine kit for 16 EN	108118
Special voltage (upon request)	-
Wi-Fi module	108137
Open Kitchen cloud solution	-

## CareCycle

	Item number
CareCycle Clean tablets	106032
CareCycle Descale tablets	106033
HydroShield L 3600 Complete	108138
HydroShield XL 6000 Complete	108139
HydroShield L 3600 Replacement filter	30500545
HydroShield XL 6000 Replacement filter	30500546

## Trolleys

	Item number
Roll-in trolley 16 EN- 400x600 80mm 16 trays L-shaped	107591
Roll-in trolley 16 EN- 400x600 95mm 14 trays L-shaped	108148
<b>Options for trolleys:</b>	
Holder for trolley handle	108144

## Accessories

	Item number
16 EN power supply cables 3 meter, electric 400 V 3PN AC, 5x6 mm <sup>2</sup>	108134
All models power supply cables 3 meter, gas 230 V 1PN AC, 3x2,5 mm <sup>2</sup>	108136
Installation kit	108127
Heat shield 16 EN	108124
USB key	108128
EMS energy management system	108119

## GET IN TOUCH.

As your oven specialist,  
we always do our  
utmost to help our  
customers. Worldwide.

Lincat Limited  
Whisby Road  
Lincoln, LN6 3QZ  
United Kingdom

T: +44 1522 875500  
M: [sales@lincat.co.uk](mailto:sales@lincat.co.uk)

[www.lincat.co.uk](http://www.lincat.co.uk)

Part of

