



POUR'D

Total beverage choice, on tap

- > POUR'D can be used to dispense beverages from any concentrate or syrup source.

COMPLETE BUNDLE ORDER CODE

POUR'D Concentrate 3b
110v - 5001940C3B



FONT



CONTROL BOX



OPTIONAL

BOILER

MIX UC3 - 220v / 110v



- > To dilute with hot water
- > To add separate hot water

CHILLER / CARBONATOR

FRIIA



- > To dilute with either chilled or sparkling water
- > To add separate chilled or sparkling water

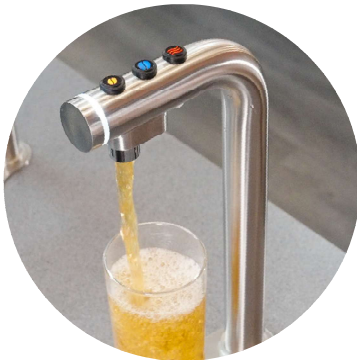

RECOMMENDED DILUTION RATIOS

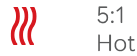

5:1
Hot



1:1 - 30:1
Cold/Sparkling



GOOD TO KNOW

POUR'D can be used with:
Concentrates & Syrups with
Max Viscosity of 700 CPS

Minimum 4ml concentrate
to 125ml final beverage

POUR'D SET-UP

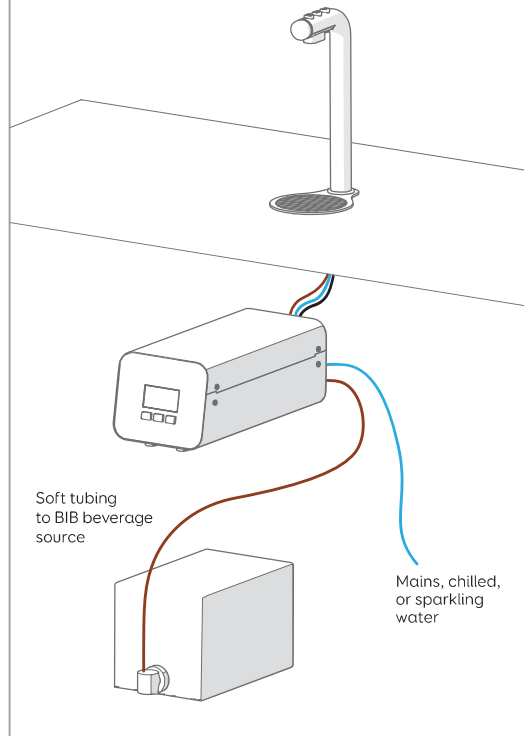

POUR'D SPECS

	OPTIONAL				
	FONT	CONTROL BOX	BOILER		CHILLER / CARBONATOR
	3B POUR'D FONT 1000942	POUR'D Control Box 1001944US	MIX UC3 220v - 1000880US	MIX UC3 110v - 1001880	FRIIA 1001860US / 1001861US
Dimensions (D x W x H inches)	6.6 x 4.9 x 11.8 (Incl. drip tray)	14.2 x 5.5 x 6.9 (width not including tubing)	15.1 x 8.2 x 17.4		17.1 x 10.2 x 17.9
Power	—	40W, 0.17A @ 110V	2.8kW @ 220v	1.4kW @ 110v	180W @110v
Plumbing	—	3/8" Compression or 3/8" push fit	3/8" Compression or 3/8" John Guest		3/8" Compression or 3/8" John Guest
NEMA	—	5-15p	L6-20P	5-15p	5-15p
Drain Required	Y	-	-	-	-
GAL/HR	—	33.3	7.3	3.6	7.9-11.8 GALS/hr based on incoming water temp of 59°F and output water temp of 41-44°F
Performance Specs	—	Dilution Range: 1:1 - 30:1	Immediate Draw Off: 0.8 GAL		Cups/HR: 175-235 (ΔT = 18 °F)
Compressor Power	—	—	—	—	1/8hp
Charge	—	—	—	—	45g
Refrigerant	—	—	—	—	R290

PACKAGING

ITEM	PACKAGING DIMENSIONS (L x W x H inches)	WEIGHT	QTY / PALLET
Font	11.4 x 22.4 x 8.4	4.4lb	54
Control Box	16.5 x 10.2 x 13	12.4lb	48/36 (sea/air freight)
MIX UC3 - 220v/110v	17.7 x 11.4 x 21.2	25lbs	24
FRIIA Chiller/Carbonator	19.2 x 11.8 x 20.2	69.4lbs	5

POUR'D CAN DILUTE/DISPENSE:

Non-Dairy Milks	✓	Dairy Milk	✗
Syrups	✓	Thick Syrup/Molasses (>700 CPS)	✗
Concentrates	✓	Kombucha	✗
Juice (no pulp, <700 CPS)	✓	Powder	✗
RTD Cold Drinks	✓	RTD Hot Drinks	✗



CONTROL BOX USE

POUR'D CONCENTRATE 3B 5001940C3B

Mains Water or Chilled Water from FRIIA

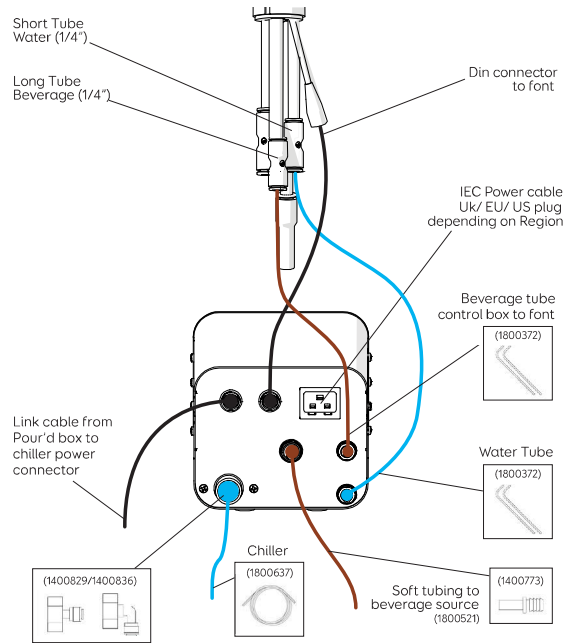
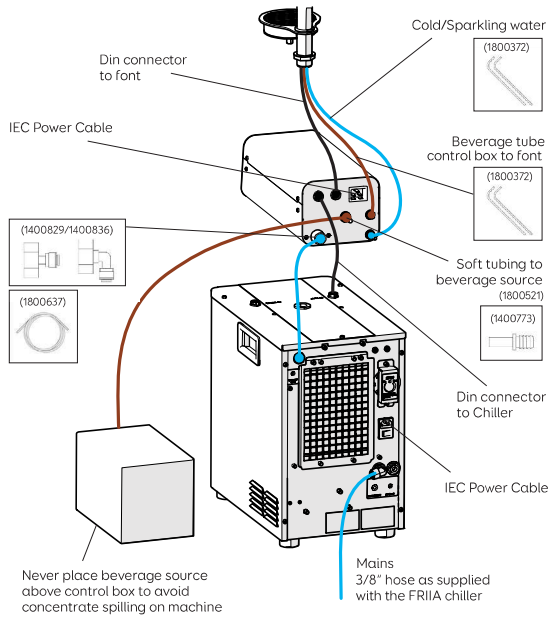

Mains Water + Hot Water Boiler

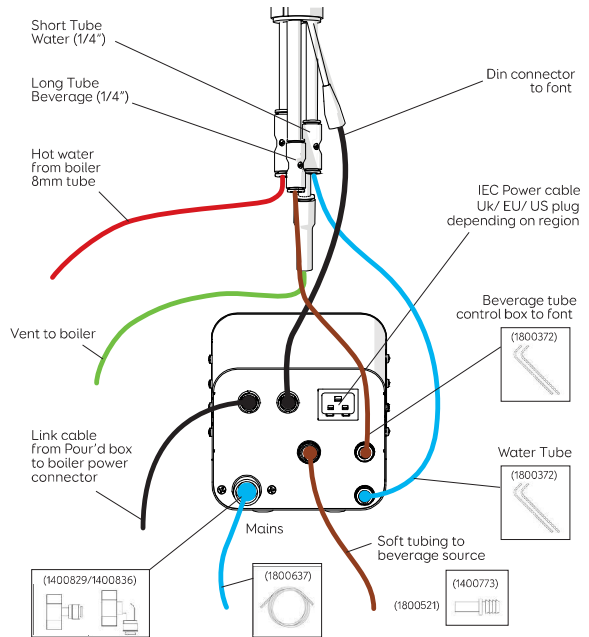
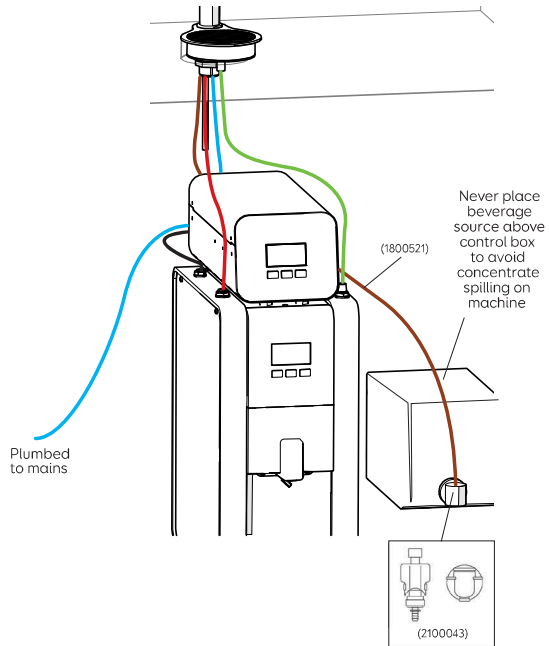



RECOMMENDED SET-UP & CLEARANCE REQUIREMENTS

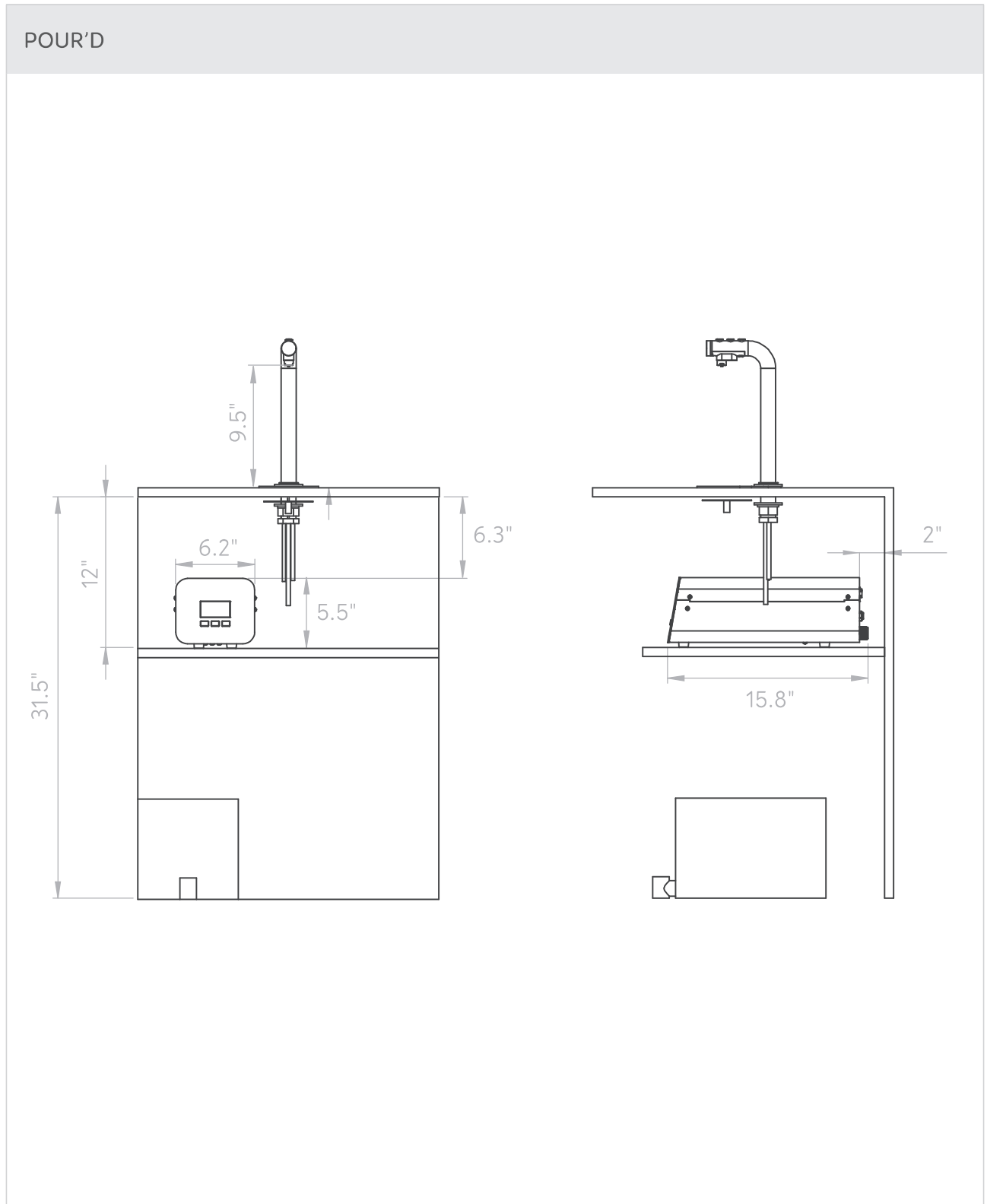



RECOMMENDED SET-UP & CLEARANCE REQUIREMENTS

POUR'D WITH MIX UC3

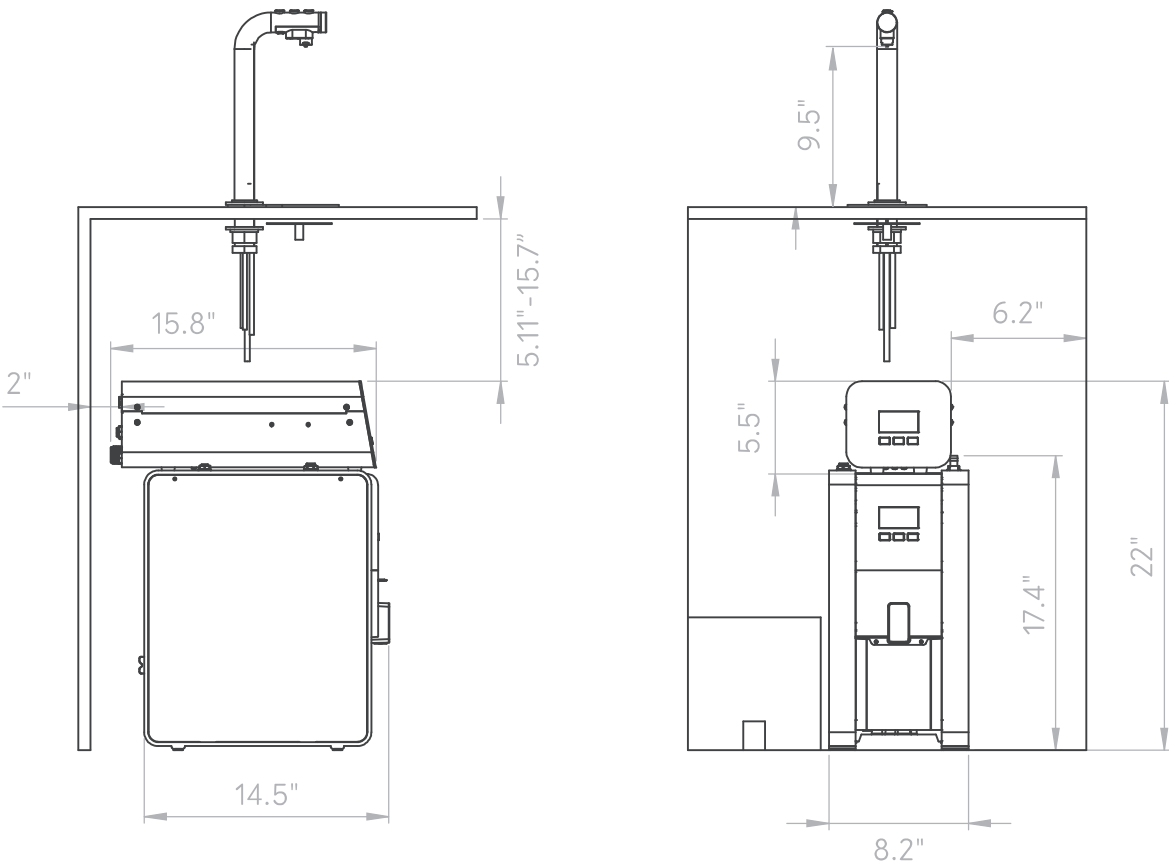



RECOMMENDED SET-UP & CLEARANCE REQUIREMENTS

