

## GAS TILTING SKILLET

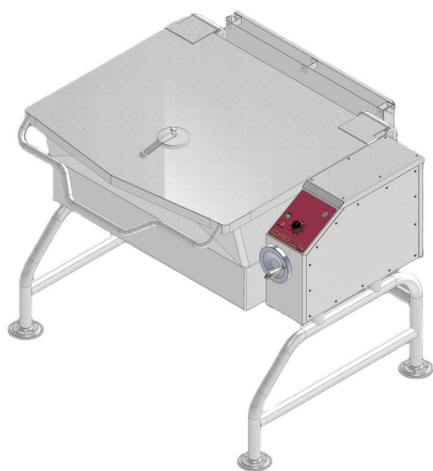

Model SKG-40

SKG-30, 30gal (114 liters)

SKG-40, 40gal (152 liters)

### OPERATION SHALL BE BY:

Natural Gas

Propane Gas

### Standard Features

- Manual or optional Power Tilt with manual override
- Redundant Safety Systems
- All Stainless-Steel Exterior
- IPX6 Water-Resistant Console

### COOKING PAN

- Resists product adherence and improves cleanup and appearance.
- Incorporates an easy-pour lip and 5-gallon increment markings.
- Interlock switch is provided to turn the burners off when the pan is tilted more than 10° from the normal horizontal position.

### CONTROLS

- Solid-state temperature control with a range of 100-450°F.
- Pilot light to indicate when the burners are ON.
- Optional power tilting mechanism also utilizes an UP/DOWN rocker switch.
- Manual tilting mechanism uses a hand crank conveniently located below the control panel.
- Controls are certified water resistant (IPX6).

### OPTIONS & ACCESSORIES AT ADDITIONAL COST

#### Pantry Faucets

- Double Pantry Faucet
- Single Pantry Faucet
- Single Pantry Spray Hose
- Double Pantry Spray Hose
- Single Pantry Faucet / with 60" Spray Hose
- Double Pantry Faucet / with 60" Spray Hose

#### Tangent Draw-Off

- 2" Draw-Off Valve w/Strainer
- 2" Tangent Draw-Off Valve w/ Drain Hose Assembly
- Power Tilt with Manual Override (PT-SKG)
- Pan Carrier (PC-SKG)
- Pan Holder Inserts
- Pouring Lip Strainer (PS-SKG)

- Caster Kit w/Strain Relief (CKSRH-SKG)
- Prison options available, Lockable Stainless Steel Hinged Control Cover, Tamper Proof Screws
- Drain Cup Assembly (DVDC-1)
- Pull-Out Sliding Sink Drain Drawer with Splash Shield (SDP-SKG)

### STANDARD CONSTRUCTION SPECIFICATIONS

The Crown SKG tilting skillets are available in 30-gallon (114-liter) and 40-gallon (152-liter) pans.

Both models are available in manual and power tilt capabilities.

Pan is formed from 10 gauge T-304 stainless steel with a #4 finish exterior and polished interior with coved corners for ease of cleaning.

The pan shall be heated with steel atmospheric burners.

The balanced design allows the operator to easily and quickly tilt to the desired position.

Our new power tilt operates smoothly, with manual override that works easily when needed without the use of tools or drills as required by other manufactures.

SKG skillets have a fully polished stainless steel cooking surface that is easy to clean and prevents food from adhering.

Burners turn off automatically when the cooking pan is tilted from the horizontal position.

The skillet is provided with a heavy-duty spring assisted cover with a

condensate vent.

The cooking pan and cover is supported by a console with a fully welded stainless steel tubular frame system that provides stable support to the unit.

The console is completely covered with stainless steel that provides protection to the controls and is also easily cleanable and provides clear access for easy floor cleaning.

The tilting mechanism includes a precision ground and polished worm for smooth and long lasting tilt operation and positive control with a hand crank.

A power tilting option is available and is also supplied with the handle for manual override operation if required.



Approval Notes: \_\_\_\_\_

\_\_\_\_\_

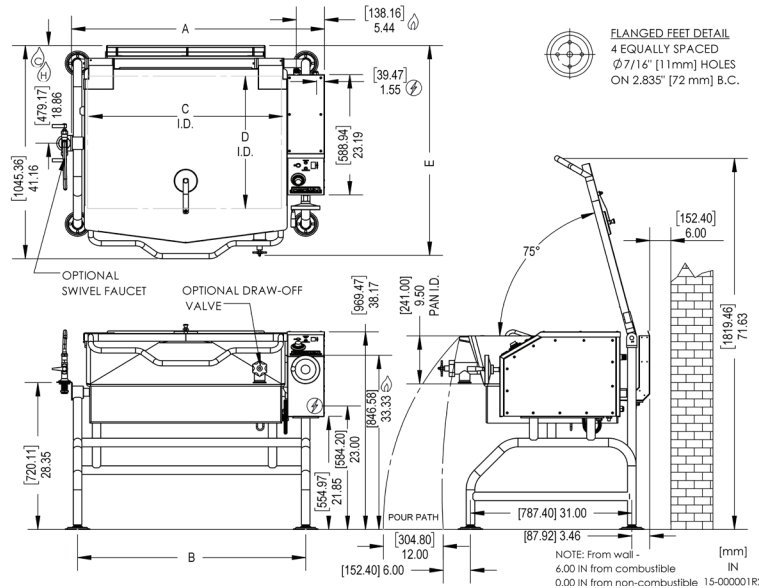

**SERVICE CONNECTIONS**

- GAS CONNECTION: Supplied through 3/4" NPT Pipe. A gas shut-off valve must be installed in supply piping convenient and adjacent to appliance
- ELECTRICAL CONNECTION: 120V Units supplied with 8' cord with 3 prong plug. Total Amps: 3A (220V & 208/240V options available).
- COLD WATER: 3/8" O.D. tubing to optional faucet. (OPTIONAL)
- HOT WATER: 3/8" O.D. tubing to optional faucet. (OPTIONAL)
- DRAIN: 1 1/2" - 1 1/2 NPT (OPTIONAL) - not shown here

**DIMENSIONS**

MODEL	CAPACITY	UNITS	A	B	C	D	E	
							Ø2	Ø3
SKG-30	30 Gallons (114 liters)	inches mm	38.64" (981 mm)	33.84" (860 mm)	27.88" (708 mm)	25.54" (649 mm)	38.25" (972 mm)	42.75" (1086 mm)
SKG-40	40 Gallons (152 liters)	inches mm	48.62" (1235 mm)	43.84" (1114 mm)	37.88" (962 mm)	25.54" (649 mm)	38.25" (972 mm)	42.75" (1086 mm)

**GAS CHARACTERISTICS**

MODEL	GAS SUPPLY		SUPPLY PIPE PRESSURE (W.C.)	
	BTU/HR	kW/HR.	Natural	Propane
SKG-30	110,000	32.2	6" - 14" (152 mm - 356 mm)	11" - 14" (279 mm - 356 mm)
SKG-40	156,000	45.7		

\* For use on non-combustible floors only.

**SPECIFICATIONS**

MODEL	CAPACITY		SHIPPING WEIGHT	MINIMUM CLEARANCE *	
	GALLON	LITER		Sides	Back
SKG-30	30	114	360 lbs. [163 kg]	Sides	0
SKG-40	40	151	450 lbs. [204 kg]	Back	6" (152 mm)

As continued product improvement is a policy of Crown, specifications are subject to change without notice.

**INTENDED FOR COMMERCIAL USE ONLY.  
 NOT FOR HOUSEHOLD USE.**

