

# 7 QT DROP-IN SINAQUA™ SOUPER



## PERFORMANCE

The SinAqua™ Souper is a drop-in countertop unit from CookTek used for rethermalizing food and precision holding. Employing a forward-thinking design and high-contrast, easy-to-use capacitive touch control, the SinAqua™ Souper can take liquid foods from an unfrozen, chilled state through the food safety danger zone in as little as 45 minutes.† After rethermalization, food is held at a precise temperature within a selectable range of 140–200 °F (60–95 °C). Utilizing CookTek inductive heating technology, the SinAqua™ Souper consistently heats food without scorching and holds food twice as long as steam wells, while using less than half the energy. The SinAqua™ Souper eliminates maintenance and plumbing associated with traditional soup warmers.

† Requires stirring

## FEATURES

- SinAqua™ (waterless) holding and rethermalization
- 800 watts induction heating
- User-selectable precision hold and rethermalization functions
- Holding temperatures range from 140–200 °F (60–95 °C)
- Rethermalizing temperatures range from 170–200 °F (75–95 °C)
- Programmable stir notification, defaults to four minutes when rethermalizing and 15 minutes when holding
- Pan compensation technology allows for use with magnetic and non-magnetic soup tureens<sup>††</sup>
- Active dry-pan protection prevents users from unintentionally damaging the unit
- Highly visible and durable capacitive touch user interface
- Audible and visual cues
- Spun aluminum exterior construction with high-gloss polycarbonate adapter ring (stainless steel adapter ring sold separately)

## STANDARD INCLUDED ACCESSORIES

- 6-ft (1.8 m) nominal plug and cord
- One-year limited warranty (U.S. and Canada only)
- One 7 qt 18/8 stainless steel soup tureen and lid for maximum performance, durability, and corrosion resistance
- 6 ft. 5-pin micro-USB patch cable from unit to control box

## OPTIONAL ACCESSORIES

- 7 qt 18/8 stainless-steel soup tureen with lid (#302409)
- 7 qt stainless-steel drop-in soup tureen adapter ring (#302381)
- 7 qt Bain-marie kit (includes water bath, 7 qt soup tureen, and lid) (#CTS-3014)



††The SinAqua Soupers are designed to be used exclusively with CookTek-specific tureens and lids.

It is the owner and installer's responsibility to comply with all local codes. CookTek reserves the right to substitute components or change specifications without prior notice.

SOUP7QT-DI-SPC-A / January 2026

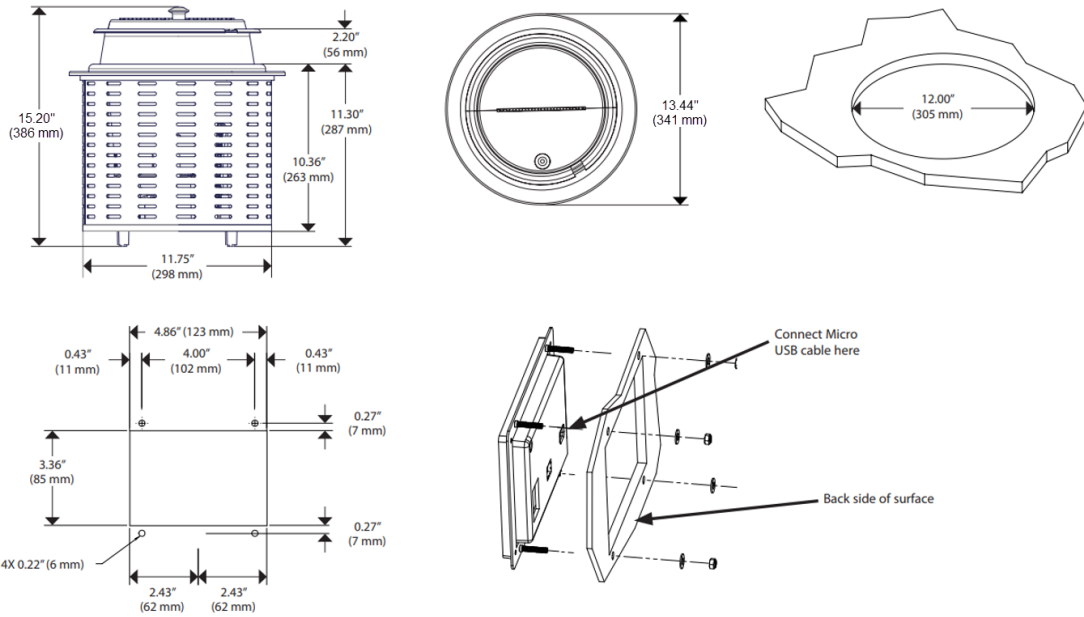

DIMENSIONS		
Unit Height	15.20"	386 mm
Diameter (overhang)	13.44"	341 mm
Cutout Diameter	12"	305 mm
Weight	11.55 lb	5.2 kg
Max Ambient Temperature	131 °F	55 °C

SHIPPING INFORMATION		
Packaged Height	18"	457 mm
Packaged Width	17"	432 mm
Packaged Depth	17"	432 mm
Packaged Weight	17 lb	7.7 kg
Item Class	1405001104	

ELECTRICAL SPECIFICATIONS			
UNITED STATES/CANADA			
SASD081-7	677101	100-120 VAC, 50/60 Hz, 7A, 800 W	NEMA 5-15P
SASD082-7	677201	200-240 VAC, 50/60 Hz, 4 A, 800 W	
UK/MIDDLE EAST			
SASD082-7	677202	200-240 VAC, 50/60 Hz, 4 A, 800 W	BS1363, 13 A, 230 V
INTERNATIONAL			
SASD082-7	677203	200-240 VAC, 50/60 Hz, 4 A, 800 W	CEE 7/7 Schuko, 16 A, 250 V
AUSTRALIA			
SASD082-7	677204	200-240 VAC, 50/60 Hz, 4 A, 800 W	AS/NZS 3112:2000, 10 A, 250 V
SOUTH AFRICA			
SASD082-7	677207	200-240 VAC, 50/60 Hz, 4 A, 800 W	BS 546, 16 A, 250 V
ISRAEL			
SASD082-7	677208	200-240 VAC, 50/60 Hz, 4 A, 800 W	SI 32, 16 A, 250 V



AS/NZS 3112:2000, 10 A, 250 V



NEMA 5-15P



BS1363, 13 A, 230 V



SI 32, 16 A, 250 V



BS 546, 16 A, 250 V



CEE 7/7 Schuko, 16 A, 250 V