

# 62

## Shake Freezer

Four Flavor

### Features

Offer four separate shake flavors: chocolate, strawberry, vanilla (unflavored shake mix), and an optional flavor.

### Freezing Cylinder

One, 7 quart (6.6 liter).

### Mix Hopper

One, 20 quart (18.9 liter). Separate hopper refrigeration (SHR) maintains mix below 41°F (5°C).

### Indicator Lights

Add Mix light alerts the operator to add mix. When the Mix Out light flashes, the unit automatically shuts down to prevent damage.

### Accurate Consistency Control

Torque control precisely maintains superior shake quality in texture, viscosity, and taste.

### Shake Syrup System

Shake flavors are selected from push-buttons. Three 1 gallon (3.8 liter) syrup tanks are provided. Optional air compressor or CO<sub>2</sub> may be used to pump syrup from the remote tanks. Use only single strength syrup, free from pulp and seeds. Syrup tanks must be located within 5 feet (1.5 m) of the freezer.

### Automatic Dispensing

Press the desired flavor and raise the draw handle. Frozen shake mix and syrup automatically blend to dispense the chosen flavor. After the shake is drawn, press the Rinse button to eliminate flavor carryover. Rinse water connection under unit is 3/8 in. FPT.



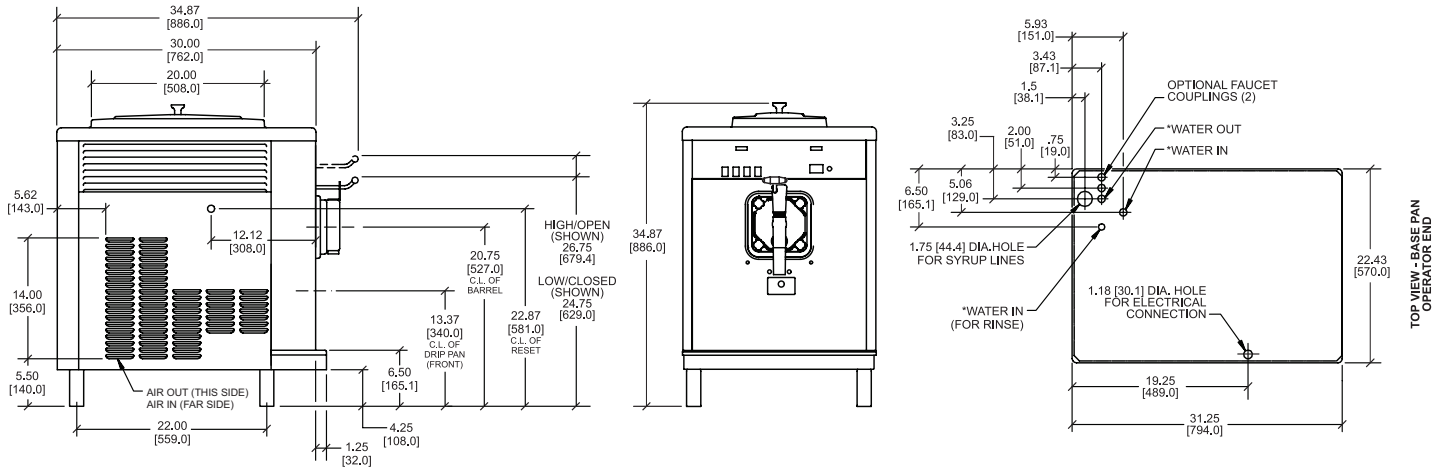

FIGURES IN BRACKETS INDICATE MILLIMETERS / DECIMAL AND FRACTIONAL DIMENSIONS EQUAL TO ( PLUS OR MINUS 1/16 INCH [1.5mm] ). \*WATER COOLED ONLY

Weights	lbs.	kgs.	
Net	346	157.0	
Crated	414	188.0	
<i>*For reference only</i>			
	cu. ft.	cu. m.	
Volume	29.9	.85	
Dimensions	in.	mm.	
Width	22-7/16	570	
Depth	34-7/8	886	
Height	34-7/8	886	
Counter Clearance	4-1/4	108	
<i>*Mounted on standard legs</i>			
Electrical	Maximum Fuse Size	Minimum Circuit Ampacity	Poles (P) Wires (W)
208-230/60/1 Air	30	21	2P 3W
208-230/60/3 Air	15	14	3P 4W

This unit may be manufactured with other electrical characteristics and may have additional regulatory agency approvals. Consult the local Taylor distributor for other electrical characteristics and agency approvals based on specific electrical and country requirements.  
**(For exact electrical information, approval marks, and refrigerant, always refer to the data label of the unit.)**

**Continuing research results in steady improvements. Therefore, these specifications are subject to change without notice.**

#### Bidding Specs

Electrical: Volt \_\_\_\_\_ Hz \_\_\_\_\_ ph \_\_\_\_\_  
 Neutral: Yes No Cooling: Air Water NA

#### Options:

All options may not be available in combination with others or with all electrical or cooling configurations. Please consult your local Taylor distributor.

#### Authorized Taylor Distributor

## Specifications

### Electrical

One dedicated electrical connection is required. See the electrical chart for the proper electrical requirements. Manufactured to be permanently connected. Consult your local Taylor distributor for cord and receptacle specifications as local codes allow.

### Beater Motor

One, 1.0 hp.

### Refrigeration System

One, 10,000 BTU/hr. R449A.  
 Separate Hopper Refrigeration (SHR), One, 400 BTU/hr. R134a.  
 (BTUs may vary depending on compressor used.)

### Air-Cooled

Minimum Clearance: 6 in. (152 mm) around all sides. Minimum air clearances must be met to ensure adequate airflow for optimum performance.

### Water-Cooled

Water inlet and drain connections underside of base 3/8 in. FPT.

## Accessories

- Air Compressor



750 N. Blackhawk Blvd.  
 Rockton, Illinois 61072  
[www.taylor-company.com](http://www.taylor-company.com)