

# 430

## Frozen Beverage Freezer

Single Flavor

### Features

Vary your menu by offering shakes and smoothies or frozen cocktails, fruit juices, coffees, cappuccino and tea slush beverages, all served at the desired thickness.

### Freezing Cylinder

One, 4 quart (3.8 liter).

### Mix Hopper

One, 14 quart (13.2 liter). Refrigerated to maintain mix below 41°F (5°C). Approved for dairy and non-dairy products.

### Indicator Lights

Add Mix light alerts the operator to add mix. When the Mix Out light flashes, the unit automatically shuts down to prevent damage.

### Automatic Consistency Control

A specially designed viscosity control automatically maintains superior product quality. An adjustable control allows the operator to serve a wide variety of frozen beverages at the desired thickness.



Shown with optional decals

#### Approval Mark Note:

The Approval marks shown below may not apply to every model configuration. Approvals may vary based on Voltage, Model Option and Accessory selection, please contact your local distributor for more information.

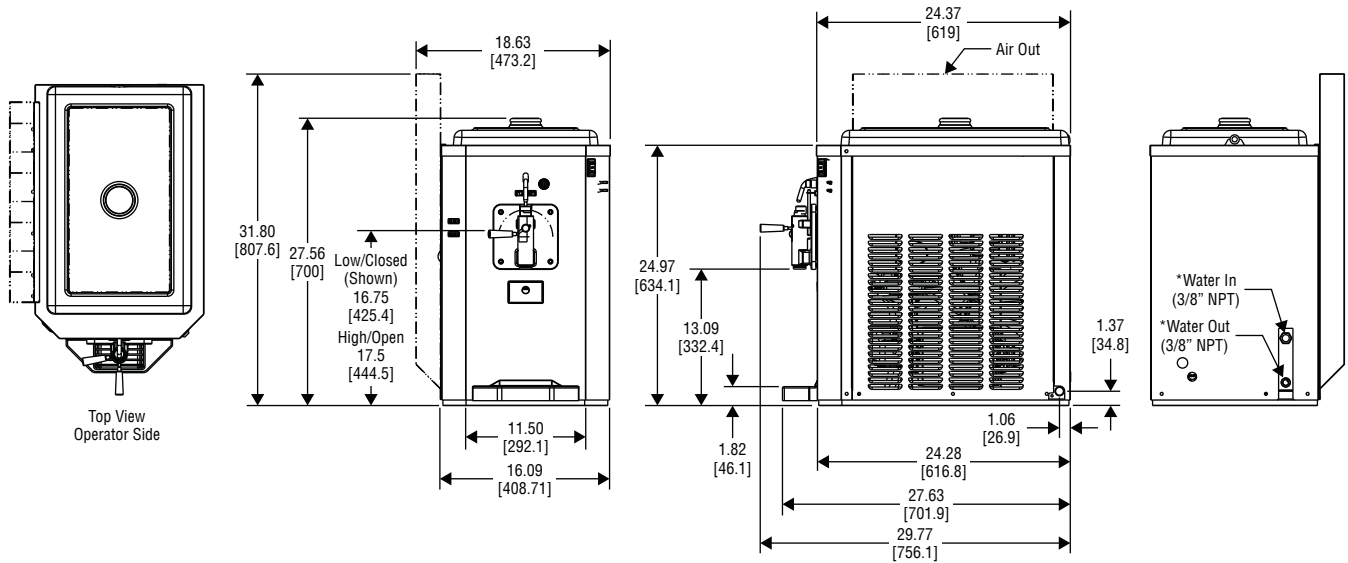

FIGURES IN BRACKETS INDICATE MILLIMETERS / DECIMAL DIMENSIONS EQUAL TO (PLUS OR MINUS 1/16 INCH [1.5 MM]).

Weights	lbs.	kgs.
Net	176	79.8
Crated	207	93.9
<i>*For reference only</i>		
	cu. ft.	cu. m.
Volume	17.7	0.50
Dimensions	in.	mm.
Width	16-7/8	408
Depth	27-5/8	701
Height	27-9/16	700
Counter Clearance	---	---
<i>*Designed to rest on a plastic pad directly on countertop</i>		
Electrical	Total Amps	Supplied with NEMA Cord
115/60/1 Air	15.0	5-20P
208-230/60/1 Air	9.0	6-15P
220-240/50/1 Water	7.6	---

This unit may be manufactured with other electrical characteristics and may have additional regulatory agency approvals. Consult the local Taylor distributor for other electrical characteristics and agency approvals based on specific electrical and country requirements.  
**(For exact electrical information, approval marks, and refrigerant, always refer to the data label of the unit.)**

**Continuing research results in steady improvements; therefore, these specifications are subject to change without notice.**

#### Bidding Specs

Electrical: Volt \_\_\_\_\_ Hz \_\_\_\_\_ ph \_\_\_\_\_  
 Neutral: Yes No      Cooling: Air Water NA

#### Options:

All options may not be available in combination with others or with all electrical or cooling configurations. Please consult your local Taylor distributor.

#### Authorized Taylor Distributor

## Specifications

### Electrical

One dedicated electrical connection is required. See the electrical chart for the proper electrical requirements. Manufactured to be cord connected. Consult the international Taylor distributor for cord and receptacle specifications for 50 Hz. equipment.

### Refrigeration System

One, approximately 7,100 BTU/hr. compressor. R449A.  
 (BTUs may vary depending on compressor used.)

### Beater Motor

One, 1/4 hp.

### Air-Cooled

Minimum Clearance: 3 in. (76 mm) on both sides. It is recommended to place the rear of the unit against the wall. Minimum air clearances must be met to ensure adequate airflow for optimum performance.

### Water-Cooled

Water inlet and drain connections out of rear 3/8 in. FPT.

## Options

- Flavor Burst Connection
- Graphic Panel Decals
- Panel Spinner
- Set of Four Flavor Cards; Frozen Drinks, Frozen Fruit Drinks. Frozen Cocktails, Smoothies



750 N. Blackhawk Blvd.  
 Rockton, Illinois 61072  
[www.taylor-company.com](http://www.taylor-company.com)