



**Integrated Syrup Rail Option**  
2 room temperature with lids & ladles, 2 heated with syrup pumps

Item No. \_\_\_\_\_

# C712

## Soft Serve Freezer

Twin Twist, Pump

### Features

Offers all the popular soft serve variations from low or non-fat ice creams, to custards, yogurt, and sorbet. Serve two separate soft serve flavors or an equal combination of both in a twist.

### Freezing Cylinder

Two, 3.4 quart (3.2 liter).

### Mix Hopper

Two, 20 quart (18.9 liter). Simplified air/mix pumps deliver the precise amount of air and mix to the freezing cylinders and reduce operator parts. Separate hopper refrigeration (SHR) maintains mix below 41°F (5°C) during Auto and Standby modes.

### Indicator Lights

Digital readout displays hours since last brush-cleaning to ensure product safety. Mix Low light alerts operator to add mix. Audible alarm may be enabled to sound when mix is low. When the Mix Out light flashes, the unit shuts down automatically to prevent damage.

### Touch Screen Controls

Microprocessor touch controls are embedded in a durable tempered glass panel. Multiple languages are selectable. Viscosity is continually measured to dispense consistent quality soft serve desserts. Temperatures in the hoppers or freezing cylinders may be displayed at any point of operation, in either Fahrenheit or Celsius. Draw counter allows operator to view number of servings dispensed.

### Standby

During long no-use periods, the Standby feature maintains safe product temperatures in the mix hopper and freezing cylinder.

### Two Locking Casters

Front casters have a locking feature for operators to keep equipment in place. The lock can be released to move the equipment for cleaning.

### Door Interlock System

Protects the operator from injury as the beater will not operate without the dispensing door in place.

### Freezer Door

A specially designed thermoplastic door allows quick ejection of product with a simple movement of the draw handle. Self-closing draw handles are standard.

### Approval Mark Note:

The Approval marks shown below may not apply to every model configuration. Approvals may vary based on Voltage, Model Option and Accessory selection, please contact your local distributor for more information.

750 N. Blackhawk Blvd. Rockton, Illinois 61072  
**800-255-0626**  
Phone 815-624-8333 Fax 815-624-8000  
**www.taylor-company.com**  
info@taylor-company.com

ISO 9001:2015  
Registered Firm



Standard 6



LISTED  
SA2650



Selected 50/60  
Hz. Models

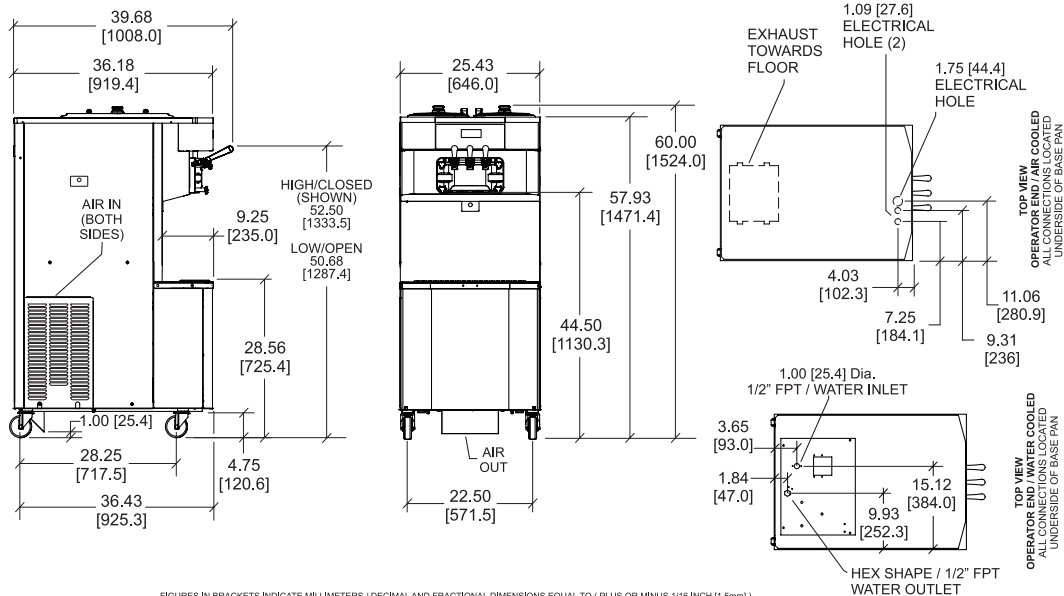

FIGURES IN BRACKETS INDICATE MILLIMETERS / DECIMAL AND FRACTIONAL DIMENSIONS EQUAL TO ( PLUS OR MINUS 1/16 INCH [1.5mm] ).

Weights	lbs.	kgs.
Net	777	352.4
Crated	855	387.8

\*For reference only

	cu. ft.	cu. m.
Volume	68.4	1.94

Dimensions	in.	mm.
Width	25-7/16	646
Depth	36-3/16	919
Height	60	1524
Floor Clearance	4-3/4	121

\*Mounted on standard casters.

Electrical	Maximum Fuse Size		Minimum Circuit Ampacity		Poles (P) Wires (W)
	Left	Right	Left	Right	
208-230/60/1 Air	30	25	22	20	2P 3W
208-230/60/1 Air, Syrup	30	25	24	20	2P 3W
208-230/60/1 Water	30	25	22	20	2P 3W
208-230/60/3 Air	15	15	15	13	3P 4W
208-230/60/3 Water	15	15	15	13	3P 4W
220-240/50/1 Air	25	25	20	18	2P 3W
380-415/50/3N- Air	10	9	9	8	4P 5W
380-415/50/3N- Water	10	9	9	8	4P 5W
200/50/60/3 Air	15	15	15	13	3P 4W

This unit may be manufactured with other electrical characteristics and may have additional regulatory agency approvals. Consult the local Taylor distributor for other electrical characteristics and agency approvals based on specific electrical and country requirements. (For exact electrical information, approval marks, and refrigerant, always refer to the data label of the unit.)

**Continuing research results in steady improvements; therefore, these specifications are subject to change without notice.**

**Bidding Specs**

Electrical: Volt \_\_\_\_\_ Hz \_\_\_\_\_ ph \_\_\_\_\_  
 Neutral: Yes No      Cooling: Air Water NA

**Options:**

All options may not be available in combination with others or with all electrical or cooling configurations. Please consult your local Taylor distributor.

**Authorized Taylor Distributor**

**Specifications**

**Electrical**

Two dedicated electrical connections are required. See the electrical chart for the proper electrical requirements. Manufactured to be permanently connected. Consult your local Taylor distributor for cord and receptacle specifications as local codes allow.

**Beater Motor**

Two, 1.5 hp.

**Refrigeration System**

Two, 10,100 BTU/hr. R449A. Separate Hopper Refrigeration (SHR), one, 400 BTU/hr. R134a. (BTUs may vary depending on compressor used.)

**Air-Cooled**

Minimum 3" (76 mm) around all sides. Install the deflector provided to prevent recirculation of warm air. Minimum air clearances must be met to ensure adequate airflow for optimum performance.

**Water-Cooled**

Water inlet and drain connections underside of base 1/2" FPT.

**Accessories**

- Cone Dispenser
- Drain Adaptor (for ease of rinsing and cleaning)
- Draw Valve Lock Kit
- Faucet
- Hopper Locks
- Syrup Rail Kit (side mount)

**Options**

- Hopper Agitators
- Panel Spinner
- Syrup Rail (integrated)



750 N. Blackhawk Blvd.  
 Rockton, Illinois 61072  
[www.taylor-company.com](http://www.taylor-company.com)