



Shown with optional standard height cart



Optional top air discharge chute

Item No. \_\_\_\_\_

# C723

## Soft Serve Freezer

Twin Twist

### Features

Offer all the popular soft serve variations, from low or non-fat ice creams to custards, yogurt, and sorbet. Serve two separate soft serve flavors or an equal combination of both in a twist.

#### Freezing Cylinder

Two, 2.8 quart (2.7 liter).

#### Mix Hopper

Two, 14 quart (13.2 liter). Separate hopper refrigeration (SHR) maintains mix below 41°F (5°C) in Auto and Standby modes.

#### Indicator Lights

Digital readout displays hours since last brush-cleaning to ensure product safety. Mix Low light alerts operator to add mix. Audible alarm may be enabled to sound when mix is low. When the Mix Out light flashes, the unit shuts down automatically to prevent damage.

#### Touch Screen Controls

Microprocessor touch controls are embedded in durable tempered glass panel. Multiple languages are selectable. Viscosity is continually measured to dispense consistent quality soft serve desserts. Temperatures in the hoppers or freezing cylinders may be displayed at any point of operation, in either Fahrenheit or Celsius. Draw counter allows operator to view number of servings dispensed.

#### Standby

During long no-use periods, the Standby feature maintains safe product temperatures in the mix hopper and freezing cylinder.

#### Door Interlock System

Protects the operator from injury as the beater will not operate without the dispensing door in place.

#### Freezer Door

A specially designed thermoplastic door allows quick ejection of product. Push forward on the ergonomic draw handle to dispense. Self-closing draw handles are standard.

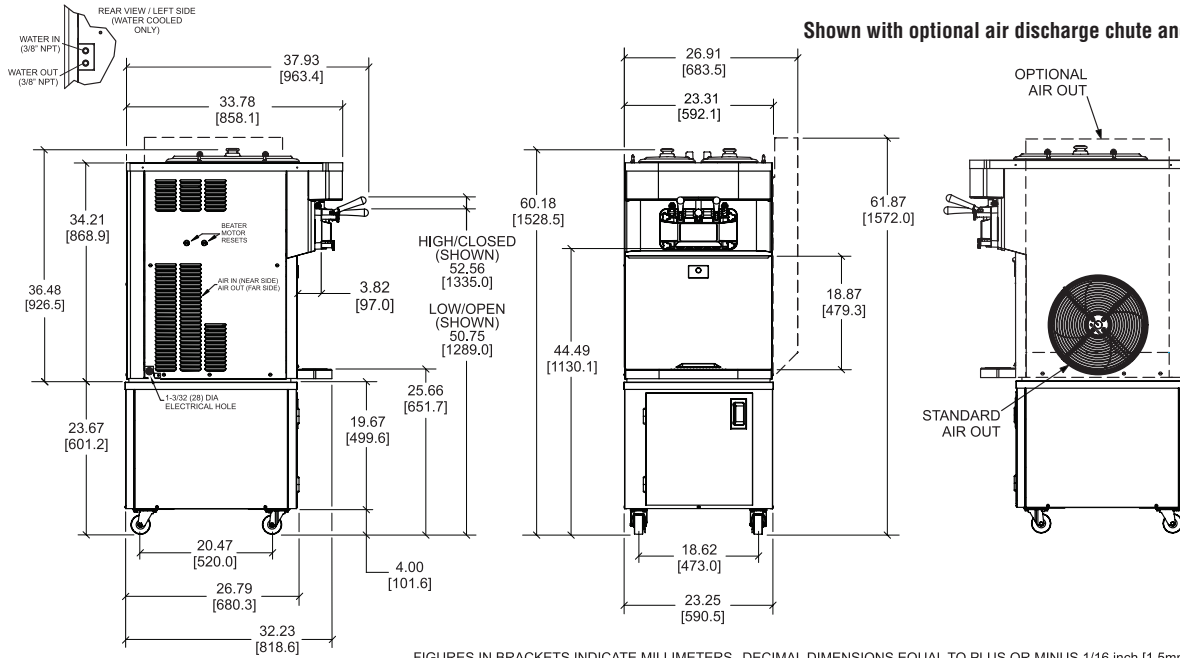

FIGURES IN BRACKETS INDICATE MILLIMETERS. DECIMAL DIMENSIONS EQUAL TO PLUS OR MINUS 1/16 inch [1.5mm].

Weights	lb.	kg
Net	500	226.8
Crated	559	253.6
<i>*For reference only</i>		
Volume	cu. ft.	cu. m
Volume	39.2	1.11
Dimensions	in.	mm
Width	23-5/16	592
Depth	33-13/16	858
Height	36-1/2	927

*\*Designed to rest on a plastic pad directly on countertop or optional cart*

Electrical	Maximum Fuse Size	Minimum Circuit Ampacity	Poles(P) Wires (W)
208-230/60/1 Air	30	25	2P 3W
208-230/60/1 Water	30	25	2P 3W
208-230/60/3 Air	15	15	3P 4W
208-230/60/3 Water	15	15	3P 4W
220-240/50/1 Air	25	21	2P 3W
380-415/50/3N~ Air	9	8	4P 5W

This unit may be manufactured with other electrical characteristics and may have additional regulatory agency approvals. Consult the local Taylor distributor for other electrical characteristics and agency approvals based on specific electrical and country requirements.  
**(For exact electrical information, approval marks, and refrigerant, always refer to the data label of the unit.)**

**Continuing research results in steady improvements; therefore, these specifications are subject to change without notice.**

**Bidding Specs**

**Electrical:** Volt \_\_\_\_\_ Hz \_\_\_\_\_ ph \_\_\_\_\_  
 Neutral: Yes No **Cooling:** Air Water NA

**Options:** \_\_\_\_\_

**Authorized Taylor Distributor**

Shown with optional air discharge chute and standard cart

**Specifications**

**Electrical**

One dedicated electrical connection is required. See the electrical chart for the proper electrical requirements. Manufactured to be permanently connected. Consult your local Taylor distributor for cord and receptacle specifications as local codes allow.

**Beater Motor**

Two, 1.0 hp.

**Refrigeration System**

One, 8,300 BTU/hr. R449A.  
 Separate Hopper Refrigeration (SHR), one, 400 BTU/hr. R134a.  
 (BTUs may vary depending on compressor used.)

**Air-Cooled**

Minimum 6 in. (152 mm) on both sides. It is recommended to place the rear of the unit against a wall or allow 6 in. clearance (152 mm) at the rear. Optional air discharge chute directs heated air exhaust upward. Minimum clearance above top air discharge chute is 12 in. (305 mm). No clearance required on right side if air discharge chute is used.

**Water-Cooled**

Water inlet and drain connections underside of base 3/8 in. FPT.

**Options**

- Standard Cart with casters and a door (shown)
- ADA Cart with casters
- Drain Adaptor (for ease of rinsing and cleaning)
- Draw Handles (to comply with ADA force requirement)
- Draw Valve Lock Kit
- Hopper Locks
- Legs - (increase height of unit by 4-1/4 in. [108 mm])
- Hopper Agitators
- Top Air Discharge
- C206 Cart, Standard Height with Casters
- C206 Cart, ADA Height with Casters
- C206 Cart, Standard Height with Casters, Flavor Burst ready
- C206 Cart, ADA Height with Casters, Flavor Burst ready

**All options may not be available in combination with others or with all electrical or cooling configurations. Please consult your local Taylor distributor.**

**TAYLOR®**  
 750 N. Blackhawk Blvd.  
 Rockton, Illinois 61072  
[www.taylor-company.com](http://www.taylor-company.com)