

V-Series 30 Qt. Mixer

The kitchen workhorse, for a wide range of heavy-duty mixing applications.



MODELS

- V30** 30 qt. Floor

STANDARD FEATURES

- Stainless steel top cover, planetary cover, bayonet shaft, bowl guard and legs
- IP32 rated
- Powerful 2 HP motor with variable speed drive and wide agitator speed range from 57 RPM to 311 RPMs
- #12 attachment hub with 198 RPM speed
- No bowl adapters needed to downsize bowls
- Hydraulic damper for easier bowl lowering, and single lever manually raises bowl and locks into position
- Front-mounted controls with 90-minute digital timer and emergency stop
- Durable powder coated finish used on legs and outside surfaces not constructed of stainless steel
- High torque transmission
- Permanently lubricated planetary head and attachment hub case
- Grease lubricated, anti-friction ball bearings
- Locking pin on tools instead of shaft
- Patent-pending interlock automatically turns the mixer off if bowl guard is opened or bowl is lowered
- Overload protection and no voltage release
- Non-skid rubber feet
- 6 foot cord
- cETLus and NSF listed
- Made in Denmark

STANDARD ACCESSORIES

- **VHOOK-30** – Stainless steel dough hook
- **VWHIP-30** – Stainless steel wire whip
- **VBEAT-30SS** – Stainless steel flat beater
- **VBOWL-30** – Stainless steel bowl
- **VCHUTE-30** – Stainless steel ingredient chute

WARRANTY

- **NEW!** Four-year parts & labor limited warranty

OPTIONAL ACCESSORIES/ATTACHMENTS

- 16 qt. bowl and accessories
- Bowl scraper - 16 qt. or 30 qt. options
- Bowl truck
- Correctional, Marine and Stainless steel models

To select options see back



ETL listed
Conforms to UL Std 763
Certified to CSA Std C22.2 No. 195

Approved by: _____

Date: _____

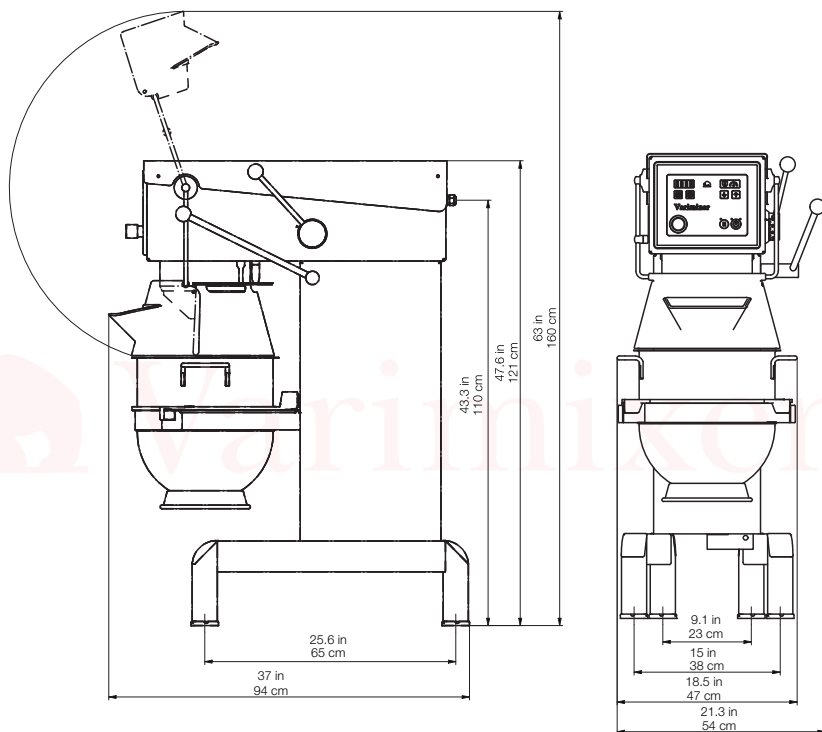

SPECIFICATIONS

Model	Motor	Volts	Amp	Plug Type	Mixing Speeds	Hub Speeds	IP Rating
V30	2 HP	120/60/1	20	--	57 - 311 RPMs	198 RPMs	IP32

Delivered without plug. Other voltages upon request with 6 to 8 week lead time.

DIMENSIONS | SHIPPING INFORMATION

Reinforced carton for shipping. This product ships on a pallet. See dimensions below.

Model	Overall Dimensions	Net Wt.	Shipping Dimensions	Ship Wt.	Freight Class
V30	21.2" W x 37" D x 47.63" H (54 cm x 94 cm x 121 cm)	374.8 lbs. (170 kg)	42.5" W x 27" D x 54" H (108 cm x 68.6 cm x 137.2 cm)	452 lbs. (205 kg)	70 55 CU ft.

OPTIONAL/ADDITIONAL ACCESSORIES

- VBOWL16-30 16 qt. bowl
- VHOOK16-30 16 qt. hook
- VWHIP16-30 wire whip
- VBEAT16-30 16 qt. flat beater
- VSCR16-30 16 qt. scraper
- VSCR16-30 16 qt. scraper
- VHDWHIP-30 30 qt. heavy-duty whip
- VWINGWHIP-30 30 qt. wing whip
- VBTRUCK-30 30 qt. bowl truck
- VBTRUCK16-30 16 qt. bowl truck
- XMCA-SS Meat grinder hub assembly
- XSVGH-XSP Housing & slicer hub assembly
- L00783 Strip cutter attachment
- L00670 Meat tenderizer attachment

Heavy-duty 30 qt. mixer with 2 HP motor, high-torque transmission and variable speed drive from 57 to 311 RPMs. IP32 rated. Mixer has front-mounted control panel with timer and emergency stop. Mixer has grease lubricated, anti-friction ball bearings and permanently lubricated planetary head & attachment hub case. Overload protection, interlocked bowl and bowl guard and no volt release. cETLus and NSF listed. Four-year parts & labor limited warranty.