

V-Series 40 Qt. Mixer

The kitchen workhorse, for a wide range of heavy-duty mixing applications.



V40

Side-mounted #12 attachment hub



MODEL

V40 40 qt. Standard

STANDARD FEATURES

- Stainless steel top cover, planetary cover, bowl guard, bayonet shaft and legs
- IP32 rated
- Powerful 3 HP motor
- Variable speed drive with agitator speed range from 53 RPMs to 294 RPMs
- #12 attachment hub with 198 RPM speed
- No bowl adapters needed to downsize bowls
- Hydraulic damper for easier bowl lowering, and single lever manually raises bowl and locks into position
- Front-mounted controls with 90-minute digital timer and emergency stop
- Durable powder coated finish on legs and outer surfaces not constructed of stainless steel
- High torque transmission
- Permanently lubricated planetary head and attachment hub case
- Bowl scraper bracket affixes to planetary head
- Grease lubricated, anti-friction ball bearings
- Locking pin on tools instead of shaft
- Patent-pending interlock prevents operation if guard is opened or bowl is lowered
- Overload protection and no volt release
- Non-skid rubber feet
- 6 foot cord
- cETLus and NSF listed
- Made in Denmark

STANDARD ACCESSORIES

- **VBOWL-40** – Stainless steel bowl
- **VBEAT-40** – Stainless steel flat beater
- **VWHIP-40V2** – Stainless steel wire whip
- **VHOOK-40** – Stainless steel dough hook
- **VCHUTE-40** – Stainless steel ingredient chute

WARRANTY

- Four-year parts & labor limited warranty

OPTIONAL ACCESSORIES/ATTACHMENTS

- 20 qt. bowl and attachments
- Bowl scraper - 40 qt. or 20 qt. options
- Bowl truck
- Correctional, Marine and Stainless steel models

To select options see back

Approved by: _____

Date: _____



ETL listed
Conforms to UL Std 763
Certified to CSA Std C22.2 No. 195

Intertek

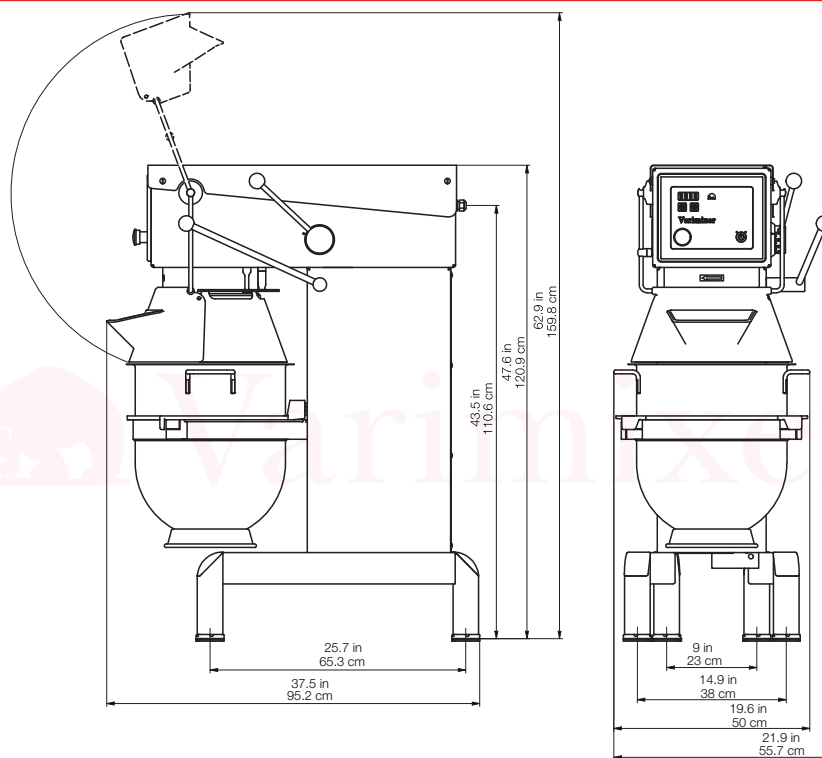

SPECIFICATIONS

Model	Motor	Volts	Amp	Plug Type	Mixing Speeds	Hub Speeds	IP Rating
V40-3	3 HP	208/60/3	9.5	--	53 - 294 RPMs	198 RPMs	IP32
V40-1	3 HP	208/60/1	14	--	53 - 294 RPMs	198 RPMs	IP32

Delivered without plug. Specify voltage when ordering.

DIMENSIONS | SHIPPING INFORMATION

Reinforced carton for shipping. This product ships on a pallet. See dimensions below.

Model	Overall Dimensions	Net Wt.	Shipping Dimensions	Ship Wt.	Freight Class
V40	21" W x 35.81" D x 47.625" H (53.34 cm x 90.96 cm x 120.97 cm)	456 lbs. (206.84 kg)	42.5" W x 27" D x 54" H (108 cm x 68.6 cm x 137.2 cm)	463 lbs. (210 kg)	70 55 CU ft.

OPTIONAL/ADDITIONAL ACCESSORIES

- VBOWL20-40 20 qt. bowl
- VHOOK20-40 20 qt. hook
- VBEAT20-40 20 qt. beater
- VWHIP20-40 20 qt. wire whip
- VWINGWHIP20-40 20 qt. wing whip
- VSCRIP20-40 20 qt. scraper
- VSCRIP-40 40 qt. scraper
- VWINGWHIP-40 40 qt. wing whip
- VHDWHIP-40 40 qt. heavy-duty whip
- VBTRUCK-40 Bowl truck
- VBTRUCK20-40 20 qt. bowl truck
- XMCA-SS Meat grinder hub assembly
- XSVGH Slicer/Shredder housing
- XSP Slicing plate
- L00783 Strip cutter
- L00670 Meat tenderizer

Heavy-duty 40 qt. mixer with 3 HP motor and variable speed drive with agitator speed range from 53 to 294 RPMs. #12 attachment hub with 198 RPM speed. Stainless steel top cover, bayonet shaft and bowl guard. Non-stainless steel surfaces powder coated finish. Front-mounted controls with 90-minute digital timer. Bowl lowering lever with hydraulic damper. Permanently lubricated planetary head and attachment hub case. 6 ft. cord. Mixer is IP32 rated with ETL and NSF certification. Four-year parts and labor limited warranty.