



IMPORTANT FOR FUTURE REFERENCE	
Please complete this information and retain this manual for the life of the equipment:	
Model #:	_____
Serial #:	_____
Date Purchased:	_____

Installation & Operation Manual

Pressure Cookers EC-2S, EC-3S, EDA-2S & EDA-3S



Model EC-3S

WARNING

Improper installation, adjustment, alteration, service or maintenance can cause property damage, injury or death. Read the installation, operating and maintenance instructions thoroughly before installing or servicing this equipment.

SOUTHBEND STEAM



A Middleby Company

1100 Old Honeycutt Road Fuquay-Varina, North Carolina 27526 USA



www.southbendnc.com



SAFETY PRECAUTIONS

Before installing and operating this equipment, be sure everyone involved in its operation is fully trained and aware of precautions. Accidents and problems can be caused by failure to follow fundamental rules and precautions.

The following symbols, found throughout this manual, alert you to potentially dangerous conditions to the operator, service personnel, or to the equipment.

 DANGER	This symbol warns of immediate hazards that will result in severe injury or death.
 WARNING	This symbol refers to a potential hazard or unsafe practice that could result in injury or death.
 CAUTION	This symbol refers to a potential hazard or unsafe practice that could result in injury, product damage, or property damage.
NOTICE	This symbol refers to information that needs special attention or must be fully understood, even though not dangerous.

IMPORTANT NOTES FOR INSTALLATION AND OPERATION

WARNING

This is the safety alert symbol. It is used to alert you to potential personal injury hazards. Obey all safety messages that follow this symbol to avoid possible injury or death.

WARNING

Improper installation, operation, adjustment, alteration, service or maintenance can cause property damage, injury or death. Read the installation, operating and maintenance instructions thoroughly before installing, operating or servicing this equipment.

WARNING

FOR YOUR SAFETY:

Do not store or use gasoline or other flammable vapors or liquids in the vicinity of this or any other appliance.

WARNING

Disconnect the power supply to the appliance before cleaning or servicing.

CAUTION

Operating, testing, and servicing should only be performed by qualified personnel.

NOTICE

This product is intended for commercial use only. NOT FOR HOUSEHOLD USE.

NOTICE

This manual should be retained for future reference.

It is recommended that this manual be read thoroughly and that all instructions be followed carefully.

Copyright © 2021 by Southbend Steam. All rights reserved. Published in the United States of America.

RETAIN THIS MANUAL FOR FUTURE REFERENCE.

Table of Contents

Important Notes For Installation and Operation	2
Service Connections	4
Installation Instructions	6
Operation	8
Boiler, CSD-1 Optional Feature	11
Cooking Guidelines.....	14
Cleaning.....	15
Maintenance	16
Troubleshooting	18

SERVICE CONNECTIONS

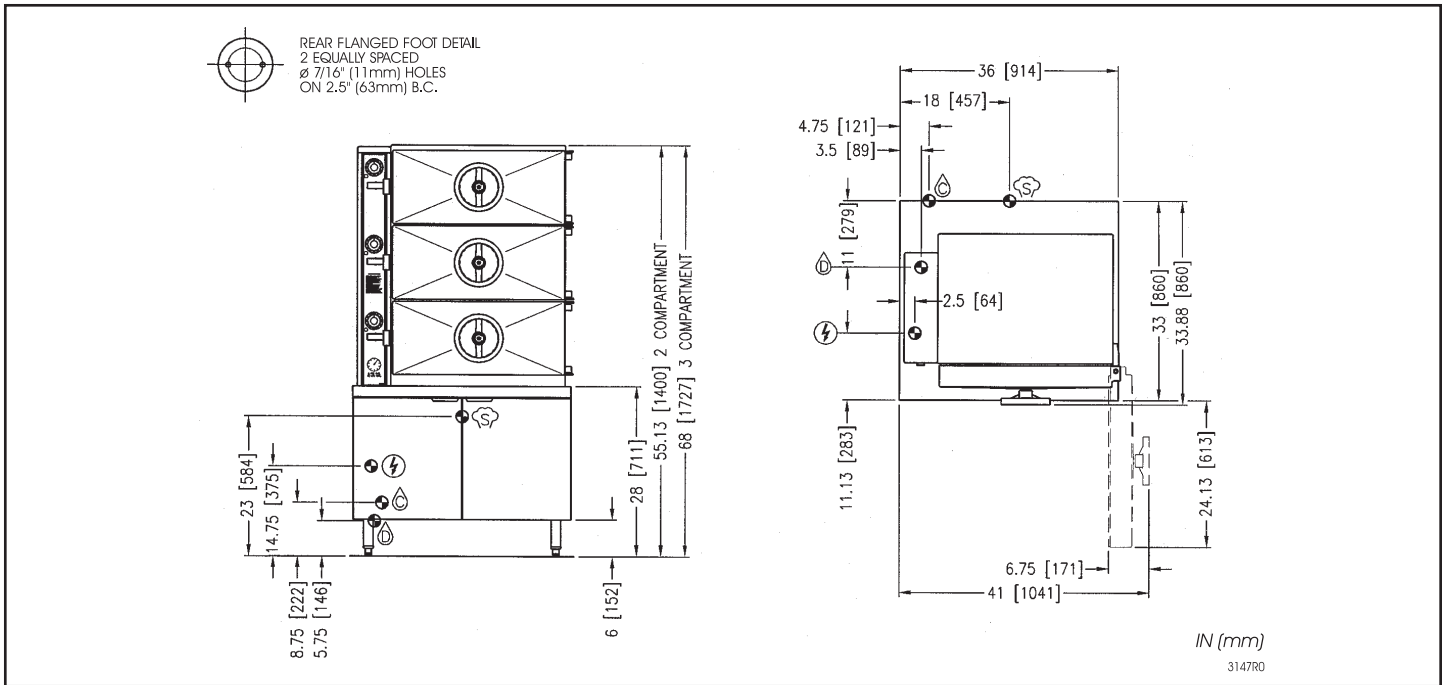

SERVICE CONNECTIONS

- COLD WATER: 3/8" O.D. tubing at 25-50 PSI (170-345 kPa)
- DRAIN: 2" (51 mm) IPS piped to open floor drain. No solid connection.
- ELECTRICAL CONNECTION: Field wiring electrical connection to be as specified on data plate.
- STEAM TAKE-OFF CONNECTION: 3/4" IPS optional to operate adjacent equipment.

ELECTRICAL CHARACTERISTICS

MODEL	PHASE	208V		220V		240V		380V		415V		480V	
		KW	AMPS	KW	AMPS	KW	AMPS	KW	AMPS	KW	AMPS	KW	AMPS
EC-2S or EC-3S	3	24	66.6	24	62.9	24	57.7	24	36.5	24	33.4	24	28.9
	3	36	99.9	36	94.5	36	86.6	36	54.7	36	50.1	36	43.3
	3	42	116.6	42	110.2	42	101.0	42	63.8	42	58.4	42	50.5

COMPARTMENT PAN CAPACITY AND WEIGHT

MODEL	COMPARTMENTS	CAPACITY
EC-2S	2	8-16 Pans
EC-3S	3	12-24 Pans

MODEL	SHIPPING WEIGHT
EC-2S	960 lbs. [435 kg.]
EC-3S	1,100 lbs. [499 kg.]

WATER QUALITY STATEMENT

Water is the essential ingredient in steam equipment, water quality is the major factor affecting the performance of your appliance. Crown Steam Group offers a Comprehensive Water Treatment System which exceeds our minimum water requirements. Proof of installation and proper cartridges replacement is required for warranty coverage. Water supply to Crown Steam Group steamers must be within these guidelines.

Total dissolved solids.....Less than 60 PPM	Chlorine.....Less than 1.5 PPM
Total alkalinityLess than 20 PPM	pH Factor6.8 - 7.3
SilicaLess than 13 PPM	

Water which does not meet these standards should be treated with the installation of Middleby's Water Treatment System. Call 919-762-1000 if you have questions concerning your water meeting these parameters.

*Failure or malfunction of this appliance due to poor water quality is not covered under warranty.

Reference www.crownsteamgroup.com for complete warranty details and instructions.

As continued product improvement is a policy of Southbend Steam, specifications are subject to change without notice.

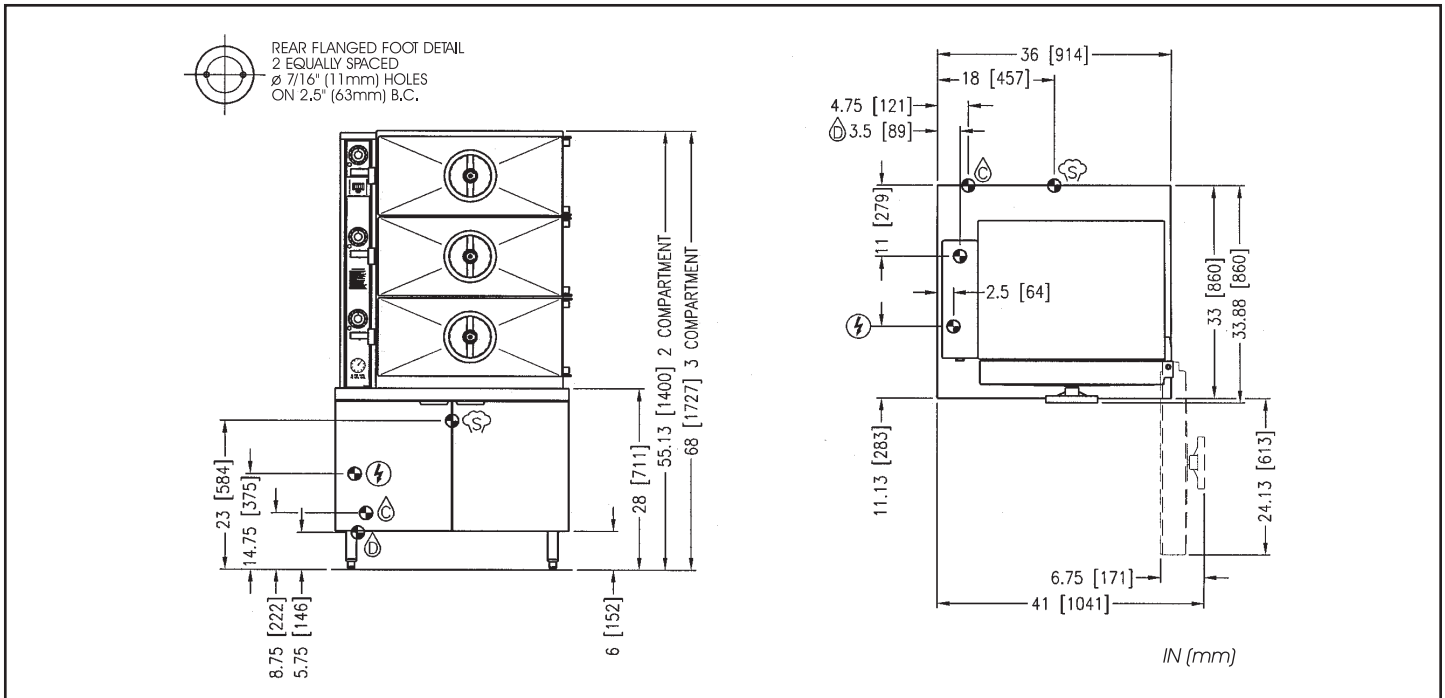

SERVICE CONNECTIONS

- ☉ - COLD WATER: 3/8" O.D. tubing at 25-50 PSI (170-345 kPa)
- ☽ - DRAIN: 2" (51 mm) IPS piped to open floor drain. No solid connection.
- ⚡ - ELECTRICAL CONNECTION: Field wiring electrical connection to be as specified on data plate.
- ☁ - STEAM TAKE-OFF CONNECTION: 3/4" IPS optional to operate adjacent equipment.

ELECTRICAL CHARACTERISTICS

MODEL	PHASE	208V		220V		240V		380V		415V		480V	
		kW	AMPS	kW	AMPS	kW	AMPS	kW	AMPS	kW	AMPS	kW	AMPS
EDA-2S or EDA-3S	3	42	116.6	42	110.2	42	101.0	42	63.8	42	58.4	42	50.5
	3	N/A	N/A	N/A	N/A	48	115.5	48	72.9	48	66.8	48	57.7

COMPARTMENT PAN CAPACITY

MODEL	COMPARTMENTS	CAPACITY
EDA-2S	2	8-16 Pans
EDA-3S	3	12-24 Pans

WATER QUALITY STATEMENT

Water is the essential ingredient in steam equipment, water quality is the major factor affecting the performance of your appliance. Crown Steam Group offers a Comprehensive Water Treatment System which exceeds our minimum water requirements. Proof of installation and proper cartridges replacement is required for warranty coverage. Water supply to Crown Steam Group steamers must be within these guidelines.

- Total dissolved solids.....Less than 60 PPM
- Total alkalinityLess than 20 PPM
- SilicaLess than 13 PPM
- Chlorine.....Less than 1.5 PPM
- pH Factor7.0 - 8.5

Water which does not meet these standards should be treated with the installation of Middleby's Water Treatment System. Call 919-762-1000 if you have questions concerning your water meeting these parameters.

*Failure or malfunction of this appliance due to poor water quality is not covered under warranty.

Reference www.crownsteamgroup.com for complete warranty details and instructions.

As continued product improvement is a policy of Southbend Steam, specifications are subject to change without notice.



INSTALLATION INSTRUCTIONS

GENERAL

Models EC-2S and EC-3S cookers have two or three pressurized steaming compartments for cooking vegetables, fish, eggs and other foods. The electric boiler in the cabinet base is ASME code designed and approved as a steam heating boiler restricted to operate at pressure not to exceed 15 psi. Boilers are available in 24, 36, 42, or 48 kW ratings and a variety of electrical specifications. Boilers may have as an option CDS1 controls.

Models EDA-2S and EDA-3S cookers also have two or three compartments; the upper compartment can be switched to provide either pressurized or pressureless steam while the lower compartment(s) provide pressurized cooking only. The electric boiler in the cabinet base is rated 42 or 48 kW.

Accessory 12 × 20" stainless steel pans are available, solid or perforated, in 2.5, 4 and 6" depth.

ACCOMMODATION

MODEL	COMPARTMENTS	TOTAL NUMBER OF PANS			NUMBER OF PANS PER COMPARTMENT		
		2.5" DEPTH	4" DEPTH	6" DEPTH	2.5" DEPTH	4" DEPTH	6" DEPTH
EC-2S, EDA-2S	2	16	8	4	8	4	2
EC-3S, EDA-3S	3	24	12	6			

Each compartment has a 0 to 60 minute timer and a buzzer that requires manual shut-off. Doors cannot be opened during cooking. Each door is equipped with an interlock feature that stops delivery of steam to the compartment before the door can be opened.

An optional Steam Take-Off Connection (3/4" NPT) can provide steam for adjacent equipment.

UNPACKING

IMMEDIATELY INSPECT FOR SHIPPING DAMAGE

Immediately after unpacking, check for possible shipping damage. If the appliance is found to be damaged, save the packaging material and contact the carrier within 15 days of delivery.

We cannot assume responsibility for damage or loss incurred in transit.

Before installing, verify the electrical rating agrees with the specification on the rating plate.

LOCATION

Position the boiler in its installation location. Check that there are sufficient clearances to service the controls, door swing, etc. Also, adequate clearance must be left for making the required supply and drain connections.

Allow enough space between any other piece of equipment or wall for service access.

Service to the controls may be required on the left and/or right side panels of the cabinet.

INSTALLATION CODES AND STANDARDS

The boiler must be installed in accordance with:

In Canada:

Provincial and local codes, or in the absence of local codes, with the Canadian Electric Code, CSA C22.1 (latest edition). Copies may be obtained from the Canadian Standards Association, 178 Rexdale Blvd., Etobicoke, Ontario, Canada, M9W 1R3.

In the USA:

State and local codes, or in the absence of local codes, with the National Electrical Code, ANSI/NFPA-70 (latest edition). Copies may be obtained from The National Fire Protection Association, Batterymarch Park, Quincy, MA, 02269.

LEVELLING AND ANCHORING THE APPLIANCE

1. Place appliance in the installation position.
2. Using a spirit level or pan of water, level the appliance. Then elevate the right side about 1/8" to assure proper compartment drainage.
3. Mark hole locations on the floor through the anchoring holes provided in the rear flanged adjustable feet.
4. Remove appliance from installation position and drill holes in locations marked on the floor. (See installation diagram on page 4.) Insert proper anchoring devices (not supplied).
5. Place appliance back in the installation position.
6. Recheck level.
7. Bolt and anchor appliance securely to the floor.
8. Seal bolts and flanged feet with silastic or equivalent compound.

ELECTRICAL CONNECTIONS

 **WARNING**

Electrical and grounding connections must comply with the applicable portions of the National Electrical Code and/or other local electrical codes.

 **WARNING**

Disconnect electrical power supply and place a tag at the disconnect switch to indicate you are working on the circuit.

When making electrical connections, use copper wire suitable for at least 200°F (90°C). The steamer must be grounded in accordance with the National Electrical Code or applicable local codes. The wiring diagram is located on the inside of the right panel.

EXHAUST HOOD

An exhaust system should be located directly above the steamer to exhaust steam and heat generated by the steamer.

PLUMBING CONNECTIONS

 **WARNING**

Plumbing connections must comply with applicable sanitary, safety, and plumbing codes.

WATER SUPPLY CONNECTION

The incoming cold water supply connection, at the rear of the boiler cabinet, requires 3/8" tubing and water pressure of 25 to 50 psi. A manual shut-off valve must be provided convenient to the boiler; this valve should be open when the boiler is in operation.

DRAIN CONNECTION

The boiler drain (2" IPS) should be piped to a floor drain near the boiler. There should be no solid drain connection; an "open gap" between the boiler and the floor drain is required.

STEAM TAKE-OFF CONNECTION (OPTIONAL)

When connecting adjacent equipment to the Steam Take-off Connection (3/4" NPT), follow the equipment manufacturer's instructions. Steam capacity should be carefully evaluated. If the optional steam take-off connection is provided on your steamer and is not connected to adjacent equipment, it should be plugged or capped.

OPERATION

 **CAUTION**

Operating, testing, and servicing should only be performed by qualified personnel.

 **CAUTION**

The appliance and its parts are hot. Use care when operating, cleaning and servicing the appliance.

INITIAL OPERATIONS CHECK

Start boiler (See pages 10 and 11 in this manual). In approximately 15 minutes enough steam should be available to operate the appliance.

The pressure gauge on the face of the Cooker Control Panel should indicate pressure of 5 to 6 psi. Open cooker compartment door and set timer dial to 5 minutes and pull out operating handle and observe that steam is entering the compartment.

 **CAUTION**

Stand clear of compartment opening as live steam is being released.

Set timer dial back to "0" and the buzzer will sound and may only be silenced by pushing in on the operating handle. Check each compartment in this manner.

Close compartment door and turn handwheel clockwise so the door gasket seals.

Set timer at 5 minutes. Pull out operating handle and set in position. Steam should be heard entering the compartment; also you should hear a hissing sound as compartment air exits the vent at the rear side, until replaced by steam.

Observe that door gasket seals properly and that no leaks are evident.

After five minutes: Timer should read "0", steam will stop entering compartment, the exhaust valve will open allowing steam and condensate water to exit, and the buzzer will sound.

To silence the buzzer, push in the operating handle.

Observe flow at the open drain. Steam from the compartment is cooled by a flow of cold water from the thermostatically controlled valve. Pause one minute to allow steam and condensate to exit. Turn handwheel counterclockwise to avoid pressure on the door gasket when not in use.

Move the door latch to the left to release and open the door. Check each compartment in this manner.

The heater elements cycle on and off maintaining steam pressure in the boiler from 9 to 11 psi.

Turn main power switch OFF. Open the manual blowdown valve. This will release hot water and steam from the boiler tank which mixes with cold water released by the thermostatically controlled solenoid valve and travels to the drain.

If equipped with automatic blowdown valve, hot water and steam will be released once the main power switch has been turned off.

 **CAUTION**

Live steam and accumulated hot water in the compartment may be released when the door is opened.

COMPARTMENT CONTROLS

Figure 1



- Timer (0 to 60 minutes)** - Sets the steam time for the compartment.
- Indicator Light** - Timed cycle is in progress when lit.
- Selector Switch** - PRESSURIZED means top compartment operates at 6 psi. (EDA Models Only)
PRESSURELESS means top compartment steams without pressure, the exhaust valve is open to the drain.
- Operating Handle** - PULL OUT to send steam to compartment, lock door, and enable operation. PUSH IN to silence buzzer at end of cycle.
- Door Latch** - Holds door closed and prevents door from fully opening until operating handle is pushed in; move the door latch to the left to fully open door after steam and condensate drain (1 minute) and handwheel is turned fully counterclockwise.
- Handwheel** - Turn clockwise to seal door at start of cycle. After pressure release at end of cycle, turn counterclockwise to open.
- Buzzer (not shown)** - Sounds an audible signal when timer cycle is complete. To silence buzzer, push in operating handle.
- Pressure Gauge** - Indicates steam pressure: 6 psi with compartments inactive, 4.5 - 6 psi during a cooking cycle.

STEAMING

Each cooking compartment is controlled by its own controls. When a compartment is not operating, the drain is open and the steam inlet valve from the boiler is closed. Food, properly portioned and in appropriate solid or perforated pans, is placed on rack supports (or wire shelves) in the steaming compartment. After closing and sealing the door, setting the timer, and pulling out the operating handle, the steam inlet valve from the boiler opens, allowing steam at a pressure of 6 psi to enter the compartment. Air from the sealed compartment exits through the vent until the temperature reaches 180°F; then the vent closes and the compartment can become pressurized. [On EDA models only, if the top compartment has been switched to pressureless steaming, steam enters the compartment and is exhausted to the drain without pressurizing the compartment.] Steaming continues until the timer reaches "0" and the buzzer sounds. To silence the buzzer, push in the operating handle. Wait one minute for steam or hot water to drain away. Open the door and remove the cooked food.

The cabinet (lower portion of steamer) contains the electric steam generator or boiler.

PREHEAT COMPARTMENTS

If the steamer has been standing idle and the compartments are cold, preheat before loading.

BOILER OPERATING INSTRUCTIONS

For CSD-1 equipped boilers, see CSD-1 Optional Feature for proper operating instructions in this manual.

BOILER CONTROLS (INSIDE CABINET)

- Main Power Switch**
- ON fills the boiler tank and turns the boiler heaters on. You should allow 20 minutes to fill the tank and generate steam.
 - OFF shuts off the boiler heaters and opens the Automatic Blowdown Valve, emptying the boiler tank and releasing water and steam to the drain. This should be done daily to remove sediment, lime, or scale.
- Pilot Light**
- Indicates main power is ON.
- Boiler Pressure Gauge**
- Should read 9 to 11 psi during operation; 0 psi during shutdown.
- Water Level Sight Glass**
- Observe level of water and water quality in the boiler. Murkiness in the water indicates inadequate water quality; the owner must supply proper water to the boiler (see page 4).
- Water Level Control**
- While boiler is ON, briefly open the water level control valve once a day to remove any sediment that might accumulate. (See page 24 for detailed instructions.)
- Safety Valve**
- This valve will release (pop off) if the boiler has too much pressure. Once a week, this valve should be tripped during operation to make sure it functions properly.
- Pressure Regulator**
- Reduces the steam pressure from the boiler to the steamer compartments to 6 psig. Twice a year, unscrew the large hex head plug located at the bottom of the regulator and remove and clean the strainer. Carefully reassemble.

OPERATION OF THE BOILER

If equipped with a manual blowdown valve, close it. Turn on water and power supply.

Open cabinet door and turn main power switch ON. Pilot light ignites and water begins to fill boiler - observe water gauge sight glass to verify that proper water level is reached.

Once the proper water level is reached, the heaters begin to heat the water. Heaters require about 15 minutes to begin steam generation. The boiler pressure gauge in the cabinet should indicate steam pressure in a range of 9 to 11 psi.

SHUT DOWN

Turn the Main Power Switch OFF: Open manual drain valve. If unit is supplied with Automatic Blowdown Valve, it will open, draining the boiler and releasing hot water and steam to the drain.

BOILER - CSD-1 OPTIONAL FEATURE

OPERATING, TESTING, SERVICING AND CLEANING INSTRUCTIONS

START-UP PROCEDURE

1. Close the manual blowdown valve.
2. Open cabinet door and turn "ON" power switch.
The green pilot light will come "ON." Water will begin to enter the boiler. When enough water has entered the boiler, the (amber) "STANDBY" pilot light will come on.
3. Press the "RESET" switch to begin boiler operation. The "STANDBY" pilot light will go off and the boiler will begin operation.

NORMAL BOILER OPERATING CYCLE

WATER FILL CYCLE

On the initial filling of the boiler, the reset switch must be activated to initialize the safety lockout circuit. Once the water in the boiler has reached the proper level, the level control will stop the flow of water to the boiler. As water is consumed in the production of steam, the level control will supply additional water to the boiler.

FIRING CYCLE

The elements are operated by pressure sensing devices. On initial operation, the boiler should reach 11 psi in approximately 15 minutes. At this point, the operating pressure switch will open, de-energizing the elements. Thereafter the operating pressure switch will cycle the elements between 9 and 11 psi boiler pressure.

CONDENSING DRAIN

A thermostat is located in the drain assembly and is activated by the temperature of steam. The thermostat operates the cooling solenoid, supplying water to the drain to condense the steam.

AUTOMATIC BLOWDOWN VALVE

If the unit has an automatic blowdown valve, it is activated when the main power switch is activated. The boiler will be drained should the main power switch be turned "OFF."

SAFETY LOCKOUT CONDITIONS

HIGH TEMPERATURE CONDITION

A high temperature safety device is installed on the boiler. Should the temperature exceed the limit of this device, the boiler will be shut down and put in a state of lockout. The "TEMPERATURE" pilot light (red), and the "STANDBY" pilot light (amber), will come on.

HIGH PRESSURE CONDITION

A high pressure safety switch is installed on the boiler. Should the pressure exceed the limit of this device, the boiler will be shut down and put into a state of lockout. The "PRESSURE" pilot light (red), and the "STANDBY" pilot light (amber), will come on. Should this device fail to operate, the safety relief valve will open.

LOW WATER CONDITION

A second low water safety cut off is supplied with the boiler. Should the water level fall below normal operating levels, the boiler will be shut down and put into a state of lockout. The "LOW WATER" pilot light (red), and the "STANDBY" pilot light (amber) will come on.

Daily Startup Procedure

1. Close the manual blowdown valve, if so equipped.
2. Open cabinet door and turn "ON" the power switch.

The green pilot light will come "ON". Water will begin to enter the boiler. When enough water has entered the boiler the (amber) "STANDBY" pilot light will come on.

3. Press the "RESET" switch to begin the boiler operation. The "STANDBY" pilot light will go off and the boiler will begin operation.

Daily Shutdown Procedure

1. Turn "OFF" the power switch.
2. Open the manual blowdown valve, if so equipped. If the appliance is equipped with an automatic blowdown solenoid valve, the boiler's contents, water and steam will be blown out and exhausted through the appliance drain. The cold water solenoid valve will be activated.

Complete Shutdown Procedure

If the appliance is not intended to be operational for a lengthy period, then shut it down completely.

1. Open the manual blowdown valve, if so equipped.
2. Shut off all supplies of power and water to the appliance.

Normal Boiler Operating Cycle

Water Fill Cycle

On the initial filling of the boiler, the reset switch must be activated to initialize the safety lockout circuit. Once the water in the boiler has reached the proper level, the level control will open the circuit to the fill solenoid valve, stopping the flow of water to the boiler. As the water is consumed in the production of steam, the level control will close the circuit to the fill solenoid and water will be supplied to the boiler.

Firing Cycle

The contactors are operated by pressure sensing devices. On the initial operation of the boiler, steam generation should reach 11 psi in approximately 15 minutes. At this point the "Operating Pressure" switch will open, opening the contacts. When pressure drops to 9 psi, the pressure switch closes, energizing the elements.

Should the pressure rise more than 14.5 psi the "Override Pressure Switch" will close the circuit to the override solenoid valve, releasing excess steam.

Condensing Drain

A thermostat is located in the drain assembly and is activated by the temperature of steam. The thermostat opens the cooling solenoid valve, in turn supplying water to the drain to condense steam.

Automatic Blowdown Valve

If the unit has an automatic blowdown valve, it is activated by the main power switch. The boiler will be drained should the main power switch be turned "OFF".

SAFETY LOCKOUT CONDITIONS

High Temperature Condition

A high temperature safety device is installed on the boiler. Should the temperature exceed the limit of this device, the boiler will be shut down and put in a state of lockout. The "Temperature" pilot light (red), and the "Standby" pilot (amber), will come on.

High Pressure Condition

A high pressure safety switch is installed on the boiler. Should the pressure exceed the limit of this device, the boiler will be shut down and put into a state of lockout. The "Pressure" pilot light (red), and the standby pilot light (amber), will come on. Should this device fail to operate, the safety relief valve will open.

Low Water Condition

A second low water safety cut off is supplied with the boiler. Should the water level fall below normal operating levels, this device will shut down and put the boiler in a state of lockout. The "Low Water" pilot light (red), and the "Standby" pilot light (amber) will come on.

COOKING GUIDELINES

The cooking guidelines in this manual are suggestions only. You should experiment with your food products to determine cooking times that will give you the best results. Variables which affect cooking time include size, weight, thickness of foods, temperature, density, previous condition of the foods (fresh, pre-blanching or frozen) and degree of doneness desired.

To allow steam to circulate around the pans, food must be spread evenly and not piled too high. Best results are obtained after the compartments are allowed to preheat. When all compartments are to be loaded at the same time, it is best to allow the first compartment to reach 4 - 4.5 psig before starting the next compartment. When processing frozen vegetables, use half the suggested pan weights and allow sufficient time for cooking doneness.

PRODUCT	PAN DEPTH	PERFORATED OR SOLID	WEIGHT/QUANTITY PER PAN	STEAM TIME MINUTES	PANS PER COMPARTMENT
VEGETABLES (Fresh)					
Beans, lima	2.5"	Perf.	5 lbs.	10 - 12 13 - 15	1 - 3 4 - 6
Beans, string or wax	2.5"	Perf.	6 lbs.	15 - 20 20 - 25	1 - 3 4 - 6
Broccoli, florets	2.5"	Perf.	6 lbs.	8 - 10 10 - 12	1 - 3 4 - 6
Broccoli, stalks	2.5"	Perf.	6 lbs.	10 - 15 15 - 20	1 - 3 4 - 6
Carrots, sliced	2.5"	Perf.	9 lbs.	18 - 21 21 - 25	1 - 3 4 - 6
Corn	2.5"	Perf.	5 lbs.	9 - 10 11 - 13	1 - 3 4 - 6
Peas	2.5"	Perf.	5 lbs.	6 - 7 8 - 9	1 - 3 4 - 6
Potatoes, chunked	2.5"	Perf.	10 lbs.	20 - 25 25 - 30	1 - 3 4 - 6
Spinach, cut, cleaned	4"	Perf.	3 lbs.	3 - 5 4 - 6	1 - 2 3 - 4
Vegetables, canned	2.5"	Solid	7 lbs.	4 - 5 5 - 8	1 - 3 4 - 6
OTHER FOODS					
Chicken	2.5"	Perf.	8 lbs.	18 - 25 25 - 30	1 - 3 4 - 6
Eggs, out-of-shell	2.5"	Solid	4 doz.	6 - 7 7 - 8	1 - 3 4 - 6
Eggs, in-shell	2.5"	Perf.	3 doz.	2 - 3 4 - 6	1 - 3 4 - 6
Fish, fillets	2.5"	Perf.	3 lbs.	8 - 12 10 - 15	1 - 3 4 - 6
Meatloaf	2.5"	Solid (for broth)	15 lbs.	35 - 40 40 - 45	1 - 3 4 - 6
Rice, add 1 gallon water	4"	Solid	4 lbs.	22 - 24 25 - 27	1 - 2 3 - 4
Spaghetti, add 7 quarts of water	4"	Solid	3 lbs.	20 - 22 23 - 26	1 - 2 3 - 4
Turkey	2.5"	Perf.	10 - 12 lbs.	50 - 60 60 - 75	1 - 3 4 - 6

CLEANING

 **WARNING**

Disconnect the power supply to the appliance before cleaning or servicing.

 **WARNING**

Never spray water into electric controls.

 **CAUTION**

The appliance and its parts are hot. Use care when operating, cleaning or servicing the appliance.

 **CAUTION**

Do not use cleaning agents that are corrosive.

Keep exposed cleanable areas of unit clean at all times. Use a mild soap and warm clean water. Rinse thoroughly with clean water and wipe dry with a clean soft cloth.

Remove pans, shelves, slide racks and compartment strainers and clean using mild warm clean soapy water.

Remove food sediment from compartment and thoroughly wash oven cavities, door liners and door gaskets at the end of each day or as required.

Never use steel wool on stainless steel.

Do not apply food oils or petroleum lubricants to the door gaskets.

Replace racks, shelves and compartment strainers.

Turn handwheel fully counterclockwise to retract the gasket plate and avoid pressure on the door gasket when the steamer is not in use.

MAINTENANCE

1. Water Level Control should be opened daily to blow down sediment and scalant.
2. Observe that the water in gauge glass is clean and clear. Extreme murkiness in water indicates inadequate water quality.
3. Safety valve should be tripped during operation once a week to assure that it functions properly.
4. Keep all exposed cleanable areas of unit clean at all times.
5. De-Scaling is based on water quality and usage.

⚠ CAUTION

An obstructed drain can cause personal injury or property damage.

Do not allow any sediment to be exhausted through exhaust valves (compartment drains). Remove all sediment and clean. Greasy foods may leave deposits that will accumulate in the exhaust drain and drain lines. To remove close doors and seal, set timers and at frequent intervals release operating arm and blowdown unit, releasing steam through valves and drain lines to dissolve grease.

The thrust screw in each compartment door should be lubricated each month to prevent handwheel from becoming difficult to turn. To lubricate, turn handwheel clockwise until gasket plate is fully extended. Grasp finger hooks on door plate and lift up and out. Apply grease NLG12 consistency of 285W60 viscosity liberally on thrust screw, rotate handwheel to ensure complete coverage. Replace gasket plate.

IMPORTANT INSTRUCTIONS

Be sure to flush your boiler water level control daily. Failure to follow this procedure can cause the control to malfunction resulting in serious boiler damage.

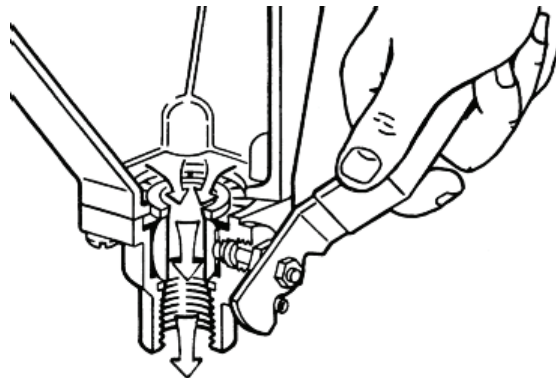

The Boiler Water Level Control installed on your boiler requires periodic maintenance. As boiler water circulates into the float chamber, sand, scale and other sediment may be deposited in the float chamber. While the chamber has been designed with a large accumulation bowl, it is necessary to flush the sediment from the chamber by blowing down the control so that the accumulation of sediment does not interfere with the movement of the float in the control.

Control must be flushed at least once a day.

⚠ CAUTION

Protect yourself. When flushing control, hot water and steam will flow out of the drain.

When flushing control, note water level in gauge glass, allow the boiler to fill if necessary, and also to come up to temperature.

Before flushing control, note that water level in gauge glass is within operating range and the boiler pressure is at least 6 psi. While the boiler is being fired, open blowdown valve at bottom of control by rotating the handle counterclockwise about 1/4 turn to fully open the valve.

Opening the blowdown valve also checks the cut-off operation. Float should drop shutting elements off, hot water and steam will flow out the drain flushing away sediment.

 **CAUTION**

If heater does not shut off during blowdown, immediately discontinue use of appliance and call for service.

Continue draining water for about fifteen (15) seconds, from control until water is clean. Manually close valve. Recheck gauge glass. If water level has dropped significantly, wait for the boiler to restore water level and pressure and repeat if necessary.

 **CAUTION**

Take extra caution when blowing down water level control or tripping safety valve as extreme hot water and live steam are present.

DESCALING BOILER

It is recommended that the boiler be checked every 90 to 120 days for scale build up. Regular maintenance should be carried out at this time.

1. With boiler empty, close manual blowdown valve. If appliance is equipped with Automatic Blowdown, turn water supply to appliance OFF. Turn power switch ON. This will energize and close blowdown valve.
2. Remove 3/4" pipe plug from fitting on left front of boiler.
3. Insert appropriate hose or tube through fitting and pour in (1/2) half gallon (U.S.) of CLR Descaling Solution.
If available, use the Optional Deliming assembly DPA-1 available from your dealer.
4. Replace 3/4" pipe plug securely.
5. Open water supply to appliance allowing water to fill boiler to required level.
6. Let appliance cycle, allow two hours for descaling and cleaning. DO NOT TURN ON STEAM to attached appliances or to upper compartment.
7. Open both the blowdown and low water level control valves for complete drainage. After boiler drains, close both valves.

TROUBLESHOOTING

COOKER

Door hasp will not engage

1. Door loose and requires new bushings.
2. Hasp requires adjustment by adding or removing of washers under hasp.

Handwheel hard to turn

1. Foreign matter on thrust screw or lack of lubricant.
2. Thrust screw bent or worn.

Door gasket leaks

1. Gasket screw loose.
2. Gasket damaged or at end of useful life.
3. Door loose and not aligned correctly.
4. Gasket plate installed incorrectly.
5. Handwheel binding so that not enough pressure to seal door.

Water accumulates in compartments

1. Appliance not levelled properly.
2. Compartment screen plugged.
3. Exhaust valve plugged or defective.
4. Exhaust drain line plugged.

Compartment pressurized at end of cooking cycle

1. Exhaust valve plugged or defective.

Steam escapes from compartment during cooking cycle

1. Compartment vent plugged.
2. Exhaust valve plugged or defective.

Cooking cycle cannot be activated

1. Loose wire terminations.
2. Steam valve plugged or defective.
3. Timer defective.
4. Micro switch on operation arm defective or requires adjustment.

Water enters compartment through steam valve

1. Water level control defective or requires cleaning.

BOILER

NOTICE

At least twice a year have an authorized service person clean and adjust the unit for maximum performance.

Water not being supplied to boiler

1. Water supply is "OFF".
2. Defective water fill solenoid.
3. Water level control clogged or defective, unable to operate fill valve.
4. Check drain valve is closed.
5. Supply water pressure too low.

Automatic blowdown valve does not drain

1. Defective blowdown valve.
2. Heat exchanger build up of scalant clogging drain lines and valve.

Boiler achieves pressure slower than normal

1. Heavy build up of lime on elements.
2. Loose element connections.

Safety valve blows

1. Defective safety valve.
2. Pressure too high, pressure switch requires adjustment (lower) or may be defective.

EC-2S, EC-3S, EDA-2S & EDA-3S Pressure Cookers



A product with the Southbend Steam name incorporates the best in durability and low maintenance. We all recognize, however, that replacement parts and occasional professional service may be necessary to extend the useful life of this appliance. When service is needed, contact a Southbend Steam Authorized Service Agency, or your dealer. To avoid confusion, always refer to the model number, serial number, and type of your appliance.



SOUTHBEND STEAM

 MIDDLEBY A Middleby Company

1100 Old Honeycutt Road Fuquay-Varina, North Carolina 27526 USA
www.southbendnc.com