



**DROP-IN AND BOTTOM-MOUNT UNSHROUDED
WARMERS WITH INFINITE SWITCH CONTROL**

MODELS:
BM-30S, BM-30DS

OWNERS MANUAL

2M-Z24237 Rev. - 05/21



This manual includes material related to installation, use, cleaning, and care. Exploded view[s], as well as any available parts list[s] and wiring diagram[s] pertaining to the unit[s] covered by this manual are also included.

This manual must be read and understood by all persons using or installing this appliance. Contact your APW Wyott dealer if you have any questions concerning installation, use, or maintenance of this equipment.

DO NOT DISCARD THIS MANUAL.

LIMITED EQUIPMENT WARRANTY

APW warrants to the original purchaser of new APW's products to be free from defects in material or workmanship, under normal and proper use and maintenance service as specified by APW and upon proper installation and start-up in accordance with the instructions supplied with each APW unit. APW's obligation under this warranty is limited to a period of one [1] year from the date of original installation, or eighteen [18] months from original invoice date, whichever occurs first. Defects that occur as a result of normal use, within the time period and limitations defined in this warranty, will at APW's discretion have the parts replaced or repaired by APW or a APW's-authorized service agency.

THIS WARRANTY IS SUBJECT TO ALL LISTED CONDITIONS

Repairs performed under this warranty are to be performed by an APW authorized service agency. APW will not be responsible for charges incurred or service performed by non-authorized repair agencies. In all cases, the nearest APW-authorized service agency must be used. APW will be responsible for normal labor charges incurred in the repair or replacement of a warrantied product within 50 miles (80.5 km) of an authorized service agency. Time and expense charges for anything beyond that distance will be the responsibility of the owner. All labor will need to be performed during regular service hours. Any overtime premium will be charged to the owner. For all shipments outside the U.S.A. and Canada, please see the International Warranty for specific details. It is the responsibility of the owner to inspect and report any shipping damage claims, hidden or otherwise, promptly following delivery. No mileage or travel charges will be honored on any equipment that is deemed portable. In general, equipment with a cord and plug weighing less than 50 lb. (22.7 kg) is considered portable and should be taken or shipped to the closest authorized service agency, transportation prepaid.

CONTACT

Should you require any assistance regarding the operation or maintenance of any APW Manufacturing; phone or email our service department. In all correspondence provide the model number and serial number of the unit needing service; include the voltage or gas type.

Normal Business Hours: 8:00 a.m. to 4:30 p.m. Central

Telephone: 800-264-7827 Tech Service Option 2

Email: TechService@partstown.com

www.apwwyott.com

WARRANTY EXCLUSIONS

THE FOLLOWING WILL NOT BE COVERED UNDER WARRANTY.

APW's sole obligation under this warranty is limited to either repair or replacement parts, subject to the additional limitations detailed below. This warranty neither assumes nor authorizes any person to assume obligations other than those expressly covered by this warranty.

- Any product which has not been used, maintained, or installed in accordance with the directions published in the appropriate installation sheet and/or owner's manual, including incorrect gas or electrical connection. APW is not liable for any unit which has been mishandled, abused, misapplied, subjected to harsh chemicals, modified by unauthorized personnel, damaged by flood, fire, or other acts of nature [or God], or which have an altered or missing serial number.
- Installation, labor, and job checkouts, calibration of heat controls, air and gas burner/bypass/pilot adjustments, gas or electrical system checks, voltage and phase conversions, cleaning of equipment, or seasoning of griddle surface.
- Replacement of fuses or resetting of circuit breakers, safety controls, or reset buttons.
- Replacement of broken or damaged glass components, quartz heating elements, and light bulbs.
- Labor charges for all removable and consumable parts in gas charbroilers and hotplates, including but not limited to burners, grates, and radiants.
- Any labor charges incurred by delays, waiting time, or operating restrictions that hinder a service technician's ability to perform service.
- Replacement of parts that fail or are damaged due to normal wear or labor for replacement of parts that can be replaced during a daily cleaning routine, such as but not limited to silicone belts, PTFE non-stick sheets, control labels, knobs, bulbs, fuses, quartz heating elements, baskets, racks, and grease drawers.
- Any economic loss of business or profits.
- Non-OEM parts. Use of non-OEM parts without APW's approval will void the warranty.
- Units exceeding one [1] year from original installation date, or more than eighteen [18] months from original invoice date, whichever comes first.

ADDITIONAL WARRANTIES

- Specific/chain-specific equipment may have additional and/or extended warranties.

The foregoing warranty is in lieu of any and all other warranties expressed or implied and constitutes the entire warranty.

TABLE OF CONTENTS

| | |
|-----------------------------------|----|
| WARRANTY | xi |
| FEATURES & OPERATING CONTROLS | 4 |
| PRECAUTIONS & GENERAL INFORMATION | 5 |
| AGENCY LISTING INFORMATION | 6 |
| INSTALLATION | 7 |
| OPERATION | 8 |
| MAINTENANCE INSTRUCTIONS | 9 |
| CLEANING INSTRUCTIONS | 10 |
| TROUBLESHOOTING SUGGESTIONS | 12 |
| EXPLODED VIEW & PARTS LIST | 13 |
| WIRING DIAGRAM | 15 |
| PARTS & SERVICE | 16 |
| CUSTOMER SERVICE DATA | 17 |

INTRODUCTION

Thank You for purchasing this APW Wyott Manufacturing appliance.

Proper installation, professional operation and consistent maintenance of this appliance will ensure that it gives you the very best performance and a long, economical service life.

This manual contains the information needed to properly install this appliance, and to use and care for the appliance in a manner which will ensure its optimum performance.

SPECIFICATIONS

| MODEL | VOLTS | AMPS | WATTS | POWER SUPPLY CORD |
|---------|--------------|----------|-------|-------------------|
| BM-30S | 120 VAC 1 PH | 10.0 Amp | 1200W | NOT SUPPLIED |
| BM-30DS | 240 VAC 1 PH | 5.0 Amp | 1200W | NOT SUPPLIED |

FEATURES & OPERATING CONTROLS

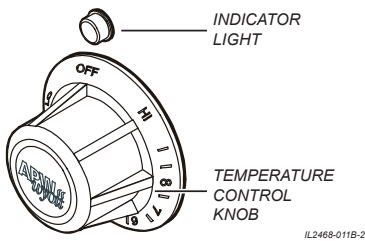

IMPORTANT:
DO NOT LEAVE ON "PRE-HEAT"

Unit may cycle on hi-limit control, leading to premature failure of the hi-limit control device.

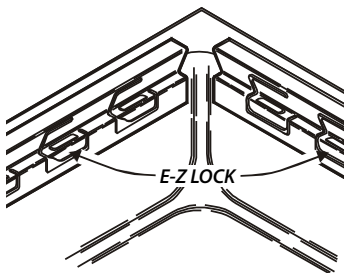

A. INFINITE SWITCH

1. On INFINITE SWITCH CONTROLLED warmers, power is applied to the heating element based on the control knob position, which varies the duty cycle of the heating element.
2. The desired temperature is controlled by rotating the TEMPERATURE CONTROL KNOB. The knob may have a numeric scale, where higher numbers correspond to higher temperature. LO is the lowest temperature setting; PREHEAT is a "continuous on" setting. Infinite switch controlled warmers are equipped with a hi-limit device to prevent overheating. The hi-limit will self-reset after the warmer has cooled.
3. On warmers equipped with an INDICATOR LIGHT, the light will glow when the infinite switch is in any position other than OFF.
4. The TEMPERATURE CONTROL KNOB will rotate without stopping, with PREHEAT and OFF having obvious detents. The OFF position is a "positive" OFF (i.e. the switch is positively held in the open position).

NOTE: An infinite switch controls temperature by varying the ratio of "on" time to "off" time. Thus, no temperature sensing device is required.

B. MOUNTING

1. Top-mounted built-in warmers are equipped with E-Z LOCK, uniquely designed turnout tabs which help secure the warmer top flange to the countertop.
2. Bottom-mounted warmers require that the cutout be flanged to provide a mounting means.
3. See the Installation Instructions, supplied with the particular appliance, for details.

C. DRAINS

1. "D" units have drains for each pan, with each pan having an individual drain valve.

PRECAUTIONS AND GENERAL INFORMATION

This appliance is intended for use in commercial establishments only.

This appliance is intended to hold pre-heated food for human consumption. No other use is recommended or authorized by the manufacturer or its agents.

Operators of this appliance must be familiar with the appliance use, limitations and associated restrictions. Operating instructions must be read and understood by all persons using or installing this appliance.

Cleanliness of this appliance is essential to good sanitation. Read and follow all included cleaning instructions and schedules to ensure the safety of the food product.

Disconnect this appliance from electrical power before performing any maintenance or servicing.

This appliance is not jet stream approved. Do not direct water jet or steam jet at this appliance, or at any control panel or wiring. Do not splash or pour water on, in or over any controls, control panel or wiring.

Exposed surfaces of this appliance can be hot to the touch and may cause burns.

Do not operate this appliance if the control panel is damaged. Call your Authorized APW Wyott Service Agent for service.

The technical content of this manual, including any wiring diagrams, schematics, parts breakdown illustrations and/or adjustment procedures, is intended for use by qualified technical personnel.

Any procedure which requires the use of tools must be performed by a qualified technician.

This manual is considered to be a permanent part of the appliance. This manual and all supplied instructions, diagrams, schematics, parts breakdown illustrations, notices and labels must remain with the appliance if it is sold or moved to another location.

This appliance is made in the USA. Unless otherwise noted, this appliance has American sizes on all hardware.



WARNING: SHOCK HAZARD

All servicing requiring access to non-insulated electrical components must be performed by a factory authorized technician. DO NOT open any access panel which requires the use of tools. Failure to follow this warning can result in severe electrical shock.



CAUTION: RISK OF DAMAGE

DO NOT connect or energize this appliance until all installation instructions are read and followed. Damage to the appliance may result if these instructions are not followed.



CAUTION: HOT SURFACE

Exposed surfaces can be hot to the touch and may cause burns.

AGENCY LISTING INFORMATION

Refer to the *product nameplate* for the specific appliance for agency listings. In general:

This appliance conforms to NSF Standard 4 for sanitation only if installed in accordance with the supplied *Installation Instructions*.

Underwriters Laboratory recognized (UL) warmers (UL File E6070) - Since the warmer is only a single component of a complete installation, the finished installation of an UL unit requires additional evaluations to Underwriters Laboratory standards.



STD 4



E6070

UL Recognized Warmers

INSTALLATION

NOTE: DO NOT discard the carton or other packing materials until you have inspected the appliance for hidden damage and tested it for proper operation. Refer to *SHIPPING DAMAGE CLAIM PROCEDURE* on the inside front cover of this manual.



WARNING: RISK OF INJURY

Installation procedures must be performed by a qualified technician with full knowledge of all applicable electrical and plumbing codes. Failure can result in personal injury and property damage.



CAUTION FIRE HAZARD

Avoid storing flammable or combustible materials in, on or near the appliance.

IMPORTANT: For warmers installed in plastic counter tops, the counter material must be protected from the heat of the warmer in order to prevent discoloration and/or deterioration. E-Z Lock are not suitable for this purpose. The installer should contact the manufacturer or distributor of the countertop material for specific instructions.

UNPACKING & INSPECTION

Carefully remove the appliance from the carton. Remove all protective plastic film, packing materials and accessories from the Appliance before connecting electrical power or otherwise performing any installation procedure.

Carefully read all instructions in this manual and the *Installation Instruction Sheet* packed with the appliance before starting any installation.

Read and understand all labels and diagrams attached to the appliance.

Carefully account for all components and accessories before discarding packing materials. Store all accessories in a convenient place for later use.

INSTALLATION NOTES

1. Installation and start up of built-in warmers **MUST** be performed by an authorized installation company.
2. It is the **RESPONSIBILITY OF THE INSTALLER** to verify that this warmer installation is in compliance with the specifications listed in this manual and on the specification sheet provided.
3. It is the **RESPONSIBILITY OF THE INSTALLER** to check with the **AUTHORITY HAVING JURISDICTION**, in order to verify that this warmer installation is in compliance with local code requirements.
4. Water supply and drain installation must meet all applicable local, state and federal plumbing codes and ordinances.
5. Refer to Installation Instructions included with the warmer for Underwriters Laboratories conditions of acceptability, electrical requirements and other installation concerns.

BUILT-IN WARMERS

1. This is a **GENERAL GUIDE**. For specific cutout dimensions and other installation details, refer to the Installation Instructions supplied with the warmer.
2. Cutout dimensions for warmer units and control panels are listed on the Installation Instructions provided with the warmer.
3. BM-30S units mount the infinite switch directly to the cabinet face. Verify style of control mounting before making cutout.

NOTE: Cutout dimensions are different for oval control panels and direct mounting, and for wood and metal counters. Verify the dimensions are correct for the installation before making the cutout.

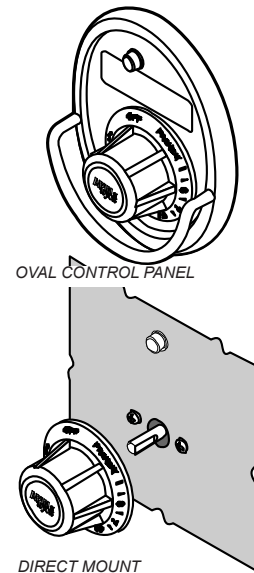

INSTALLATION

4. For “bottom-mounted” warmers (i.e. warmers mounted to a formed flange from underneath the counter top), apply a bead of food-grade silicone sealant to the top inside lip of the pan prior to attaching to the counter flange.
4. For “top-mounted” warmers (i.e. warmers mounted from above the counter top):
 - a. Verify that provided sealants are applied to the underside of the warmer top flange prior to setting the unit into the cutout.
 - b. After installation, verify that the tabs on the E-Z Lock are turned out to lock the warmer into the counter
 - c. Apply a thin bead of food-grade silicone sealant around the flange to seal it to the counter.

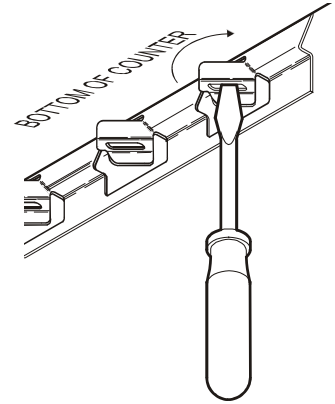

NOTE: Damage caused by leaks due to improper installation is NOT covered by warranty.



CAUTION: SHOCK HAZARD

The ground lug of this appliance must be connected to a suitable building ground.

IMPORTANT:

Contact a licensed electrician to install and connect electrical power to the appliance.

IMPORTANT:

Damage due to being connected to the wrong voltage or phase is NOT covered by warranty.

IMPORTANT: Electrical installation other than as specified on the specification sheet will void the UL listing, and may void the warranty.

NOTE: Plumb connections must be made in compliance with all Federal, State and Local Plumbing Codes and Ordinances.

ELECTRICAL INSTALLATION

1. Refer to the product nameplate. Verify the electrical service power. Voltage and phase must match the nameplate specifications. Wiring the warmer to the wrong voltage can severely damage the unit or cause noticeably decreased performance.
2. Available electrical service amperage must meet or exceed the specifications listed on the specification sheet provided with the warmer.
3. Warmer and control unit must be connected to an appropriate building ground. Ground connection will be marked “GND” or “ $\frac{1}{2}$ ”.

NOTE: Wire gauge, insulation type and temperature rating, as well as type, size and construction of conduit, must meet or exceed applicable specifications of local codes and of the National Electrical Code.

PLUMBING INSTALLATION

For use in the State of Massachusetts, this appliance must be installed in compliance with **Massachusetts Fuel Gas and Plumbing Code CMR 248**.

1. **IMPORTANT:** All plumbing installations must be performed by a qualified plumber.
2. For units equipped with a DRAIN LINE: Some jurisdictions may require an approved air gap or other back-flow prevention device in the drain. It is the responsibility of the plumber to determine such requirement, to provide and properly install the required device.

OPERATION



CAUTION: HOT SURFACE

Exposed surfaces can be hot to the touch and may cause burns.



CAUTION: SHOCK HAZARD

DO NOT splash or pour water onto control panel or wiring.

Always use an inset.

DO NOT place food directly into the warmer.

Always pour hot water into the warmer before it is preheated. DO NOT pour water into a dry, heated warmer. This may damage the unit.

DO NOT put ice into a warmer pan. This will cause condensation on the inside of the warmer. Damage caused by condensation is NOT covered by warranty.

Stir thick food items frequently to keep food heated uniformly.

Keep insets covered to maintain food quality and temperature.

WET OR DRY OPERATION for WARMERS

1. Carefully read the description of the warmer operation on the specification sheet.
2.
 - a. Most warmers are designed for WET OR DRY operation.
 - b. Warmers may be used wet, or may be used dry. However warmers may NOT be used wet-to-dry or dry-to-wet unless they have been allowed to cool to room temperature between the change in wet or dry operation.
 - c. APW Wyott Manufacturing recommends operating WET for consistent food heating.
 - d. If your wet-operation warmer is allowed to run dry, turn it OFF and allow to cool to room temperature before adding water.
3. If the warmer is to be used for WET operation, add approximately 1" of hot tap water before turning the warmer ON. Use of hot water will allow a faster preheat.
 - a. Check the water level frequently and add hot water as necessary to prevent the warmer from running dry. Do not add water to the warmer if it has run dry.
 - b. If your wet-operation warmer is allowed to run dry, turn it OFF and allow to cool to room temperature before adding water.
4. Damage caused by allowing a wet-operation warmer to run dry, is NOT covered by warranty. Damage caused by adding water to a dry warmer when hot is NOT covered by warranty.

PRE-HEATING THE WARMER

1. Place desired pan(s) or inset(s) with appropriate adapter top on warmer.
 - a. Insets are available as accessories in 2½ qt., 4qt., 7 qt., and 11 qt. sizes with lids and adapter tops.
 - b. For dry operation, a 6" deep pan or inset is recommended.
2. Infinite Switch Controlled Warmers: Turn temperature control to PREHEAT.
3. Allow warmer to PREHEAT for approximately 15 minutes, then set the control for the desired temperature. Be sure to keep the warmer covered during preheat and operation.

OPERATION

1. Always use an inset. DO NOT place food directly into the warmer.
2. Check water level in wet-operation warmer frequently during use. Running warmers dry will lower the temperature of the food in the insert pan, and may damage the warmer.
3. Alternating between wet and dry operation in any individual warmer is NOT recommended.
4. **DO NOT** use metal tools, steel wool, or caustic or abrasive cleanser to clean warmer pan.

MAINTENANCE INSTRUCTIONS

CARE OF STAINLESS STEEL

Stainless steel is a marvelous material: strong, lustrous and low maintenance. With a minimum of care, it will normally retain its beauty and durability for the life of the equipment. In some applications, however, special care is required in order to maintain stainless steel's special properties.

External components, such as cabinets and control panels, are finished with a grain pattern. This pleasing finish is best maintained by cleaning with a non-abrasive cleanser applied with a soft cloth. Rub only in the direction of the grain. In the absence of visible grain, rub only along the longest axis of the appliance.

Restore stainless steel's luster by applying a polish specifically made for stainless steel. Spray on, wipe off with a soft cloth, rubbing in the direction of the grain.

Never use metal implements, wire brushes, abrasive scratch pads or steel wool to clean stainless steel.

Warmer pans, insets and other vessels are subject to a harsher environment. APW Wyott Manufacturing uses an very high quality stainless steel (#304DDQ) for our food warmer pans. Even the highest quality stainless steel, however, is mostly iron, and will rust, pit and corrode under the following conditions:

- **Poor Water Quality:** Hard water (water with a high content of dissolved minerals) will leave mineral deposits when allowed to dry. Calcium (lime) can buildup on heated surfaces, even under water. If left unattended, hard water spots and lime buildup can lead to rusting, corrosion and pitting.
- **Contact with Chlorides:** Chlorides (specific compounds of chlorine) are found in food, table salt and many cleansers. Chlorides can attack the surface of stainless steel, resulting in corrosion and pitting.

Keep your stainless steel warmers clean and free from calcium buildup.

Use alkaline, alkaline chlorinated or non-chloride cleanser.

Use citric acid-based cleaners to remove calcium deposits.

For additional information, please read the NAFEM Stainless Steel Equipment and Cleaning Guide. Contact NAFEM at :

North American Association of Food Equipment Manufacturers

401 N. Michigan Avenue

Chicago, Illinois 60611-4267

(312) 644-6610

CLEANING INSTRUCTIONS



CAUTION: SHOCK HAZARD

Do NOT splash or pour water into or over any control panel or wiring.



CAUTION: SHOCK HAZARD

Disconnect warmer from electric power before cleaning



CAUTION: BURN HAZARD

Allow warmer to cool completely before cleaning.

DAILY CLEANING INSTRUCTIONS

PREPARATIONS: Turn control knob(s) to OFF. Allow warmer to cool before proceeding. Remove any insets, pans and/or adapter tops (if used). Drain or remove water from well if used for wet operation.

FREQUENCY: Minimum - daily.

TOOLS: Mild Detergent
Solution: 10 Parts Warm Water to 4 Parts Vinegar
Plastic Scouring Pad
Clean Cloth or Sponge
Food-Grade Silicone Sealant

1. Wipe entire unit down using a clean cloth or sponge and mild detergent.
2. Use a plastic scouring pad to remove any hardened food particles or mineral deposits. **IMPORTANT: DO NOT** use steel wool for cleaning.
3. Rinse warmer thoroughly with a vinegar and water solution to neutralize all detergent/cleanser residue.
4. Inspect warmer flange-to-counter seal. Reseal with food-grade silicone sealant if necessary. Failure to do so may allow grease and water to leak into insulation and heating element, causing a potential fire and/or electric shock hazard.
5. Inspect warmer tank for damage. Damage to the outer body may allow grease and water to leak into insulation and heating element, causing a potential fire and/or electric shock hazard. Contact your Authorized APW Wyott Service Agency to inspect warmer if water or grease contamination is suspected.
6. Close drain valve. Add proper amount of warm water. Turn control knob(s) *ON* and check for proper operation.

CLEANING INSTRUCTIONS

WEEKLY CLEANING INSTRUCTIONS

PREPARATIONS: Remove any insets, pans and/or adapter tops. Drain or remove water from well if used for wet operation.

FREQUENCY: Weekly, or whenever lime or scale is seen accumulating on the sides of the warmer pans.

TOOLS: Commercial Delime Cleaner
Plastic Scouring Pad
Clean Cloth or Sponge



CAUTION: CHEMICAL BURN HAZARD

Deilimng chemicals may be caustic. Wear appropriate personal protective equipment. Follow cleaner manufacturer's instructions for safest use.

1. Add water to pans until water is at normal operating level (1" - 1 1/2" deep) or covers accumulated scale.
2. Heat water to maximum temperature (190°F or higher).
3. Pour contents of one package of commercial delime cleaner into each warmer pan. Stir to dissolve cleaner. Turn heat control OFF. Cover pans.
4. Allow solution to soak at least one hour, or overnight for heavy scale buildup.
5. Drain hot water from pans. Scrub with a plastic scouring pad. Rinse thoroughly with hot water, then dry.
6. Refill pans with hot tap water and resume operation.
7. Heavy scale buildup may require additional treatments.

TROUBLESHOOTING SUGGESTIONS

| SYMPTOM | POSSIBLE CAUSE | SUGGESTED REMEDY |
|---|---|--|
| No power to warmer | Circuit breaker off or tripped | Reset circuit breaker |
| Warmer will not heat | Temperature control not set | Set control to desired temperature |
| Warmer trips circuit breaker | Wet insulation | Verify flange-to counter seal is sound, or reseal with food-grade silicone sealant |
| | Pan leaking or other internal damage | Contact your Authorized APW Wyott Service Agency for repairs |
| | Internal damage | Contact your Authorized APW Wyott Service Agency for repairs |
| Warmer slow to heat | Mineral deposits on pan acting as a insulator | Clean pan(s) with delime cleaner |
| | Wired to wrong voltage | Verify supply voltage - must match voltage on warmer nameplate |
| Drain-equipped unit will not hold water | Drain valve not fully closed | Check drain valve for debris and close fully |
| | Drain valve damaged or pan(s) leaking | Contact your Authorized APW Wyott Service Agency for repairs |

There are no user-serviceable components in this appliance. In all instances of damage or malfunction, contact your Authorized APW Wyott Service Agency for repairs.

EXPLODED VIEW: BM-30S, BM-30DS

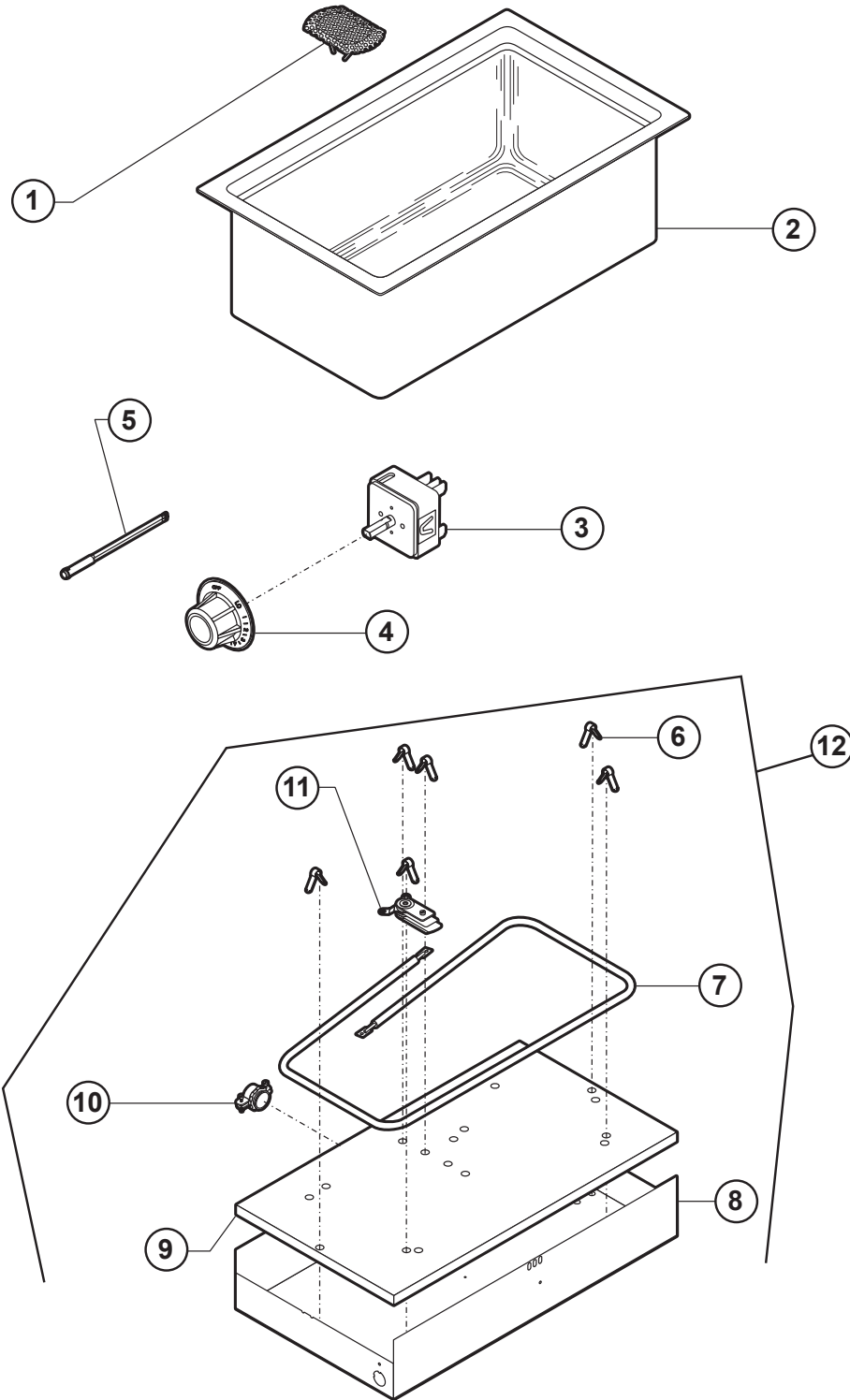

2M-Z24237 Owners Manual for BM-30S, BM-30DS Built-In Inf Sw. Warmers

Model: BM-30S, BM-30DS
PL012B

IL1862 Rev. B 2/12/15

PARTS LIST: BM-30S, BM-30DS

| BM-30S, BM-30DS | | | |
|-----------------|-----------|-----------------------------|-------------|
| Fig No | Part No | Description | Application |
| 1 | 5P-21709 | SCREEN DRAIN WARMERS | ALL |
| 2 | P2-38522 | PAN W/O DRAIN BM-30S | BM-30S |
| | P2-38523 | PAN W/DRAIN BM-30DS | BM-30DS |
| 3 | 2E-Z21557 | SWITCH INFINITE 120V | 120V |
| | 2E-Z21561 | SW INF 240V B CAM 12/16S | 240V |
| 4 | 2R-Z24182 | KNOB CONTROL ASSY WARMERS | ALL |
| 5 | WS-50385 | LIGHT SIGNAL RED PUSH ON | ALL |
| 6 | 2C-30467 | CLAMP ELEM (A) | ALL |
| 7 | WS-50396 | WARM ELEM 120V 1200W | 120V |
| | WS-50398 | WARM ELEM 240V 1200W | 208/240V |
| 8 | N1-307797 | PAN ELEM BM-30 ET | ALL |
| 9 | 2H-31882 | INSUL FG PAD MP | ALL |
| 10 | 2K-37748X | FTG CONDUIT STRAIGHT 3/8 | ALL |
| 11 | WS-50374 | THERMO HI-LIMIT SAFETY | ALL |
| 12 | P2-WL0086 | PAN ELEM ASSY BM-30 INF SWT | 120V |
| | P2-WL0085 | PAN ELEM ASSY BM-30 INF SWT | 208/240V |

WIRING DIAGRAM

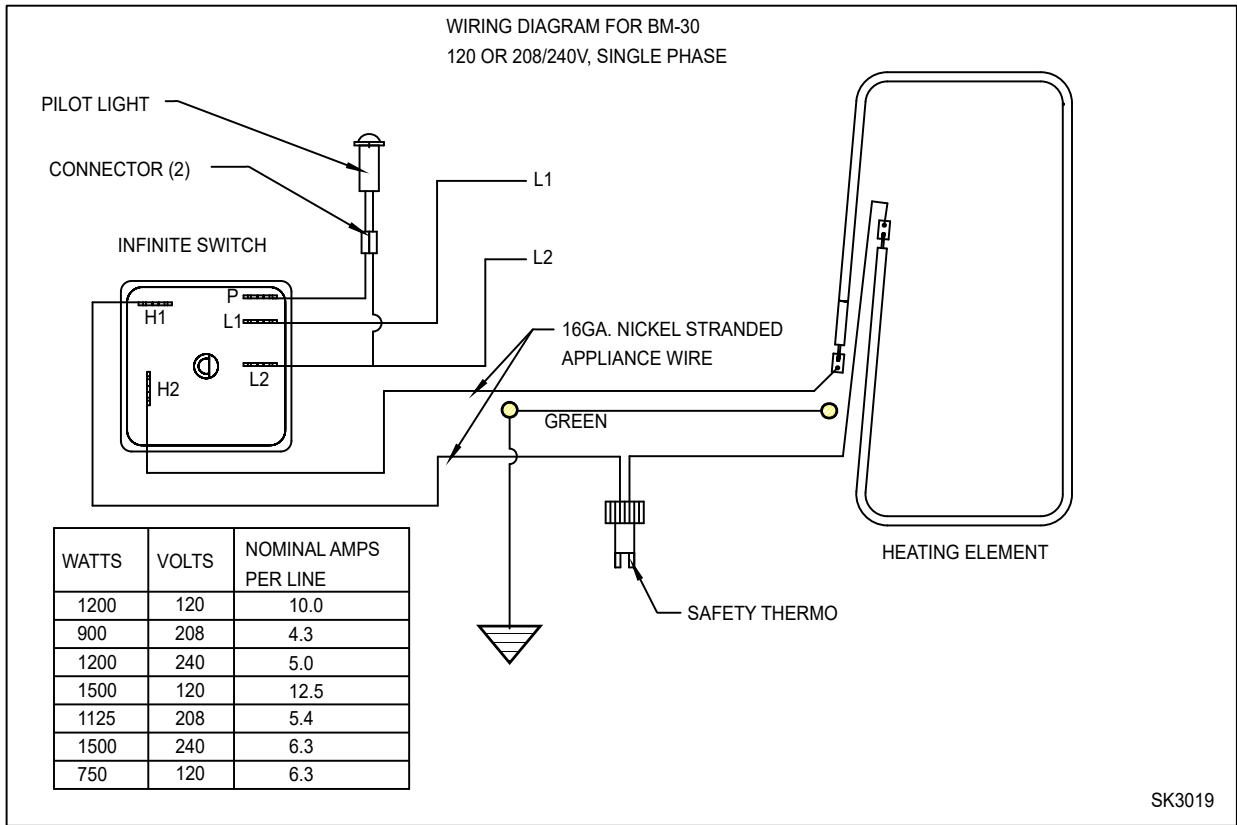

PARTS & SERVICE

Always use an inset.
DO NOT place food directly
into the warmer pan.

DESCRIPTION

PART NO.

ADAPTERS & INSETS

ADAPTER TOP, convert BM-30 to hold
two 7 qt. insets

3P-20176

ADAPTER TOP, convert BM-30 to hold
two 4 qt. insets and two 2½ qt. insets

3P-20434

PARTS & SERVICE

DESCRIPTION

ACCESSORIES

6 oz. SOUP LADLE

DRAIN VALVE EXTENSION KIT, extension from drain to counter front with remote handle, for use with "D" models only, excluding "DM" models

PART NO.

2L-47567

3P-20385

IMPORTANT: Use only factory authorized service parts and replacement filters.

For factory authorized service, or to order factory authorized replacement parts, contact your APW Wyott authorized service agency, or call:

APW Wyott
265 Hobson St.
Smithville, TN 37166
Service Dept.
Phone: (800) 527-2100

Service Parts Department can supply you with the name and telephone number of the APW Wyott AUTHORIZED SERVICE AGENCY nearest you.

2M-Z24237 Owners Manual for BM-30S, BM-30DS Built-In Inf Sw. Warmers

CUSTOMER SERVICE DATA

Please have this information available if calling for service

RESTAURANT _____ LOCATION _____

INSTALLATION DATE _____ TECHNICIAN _____

SERVICE COMPANY _____

ADDRESS _____ STATE _____ ZIP _____

TELEPHONE NUMBER (____) _____ - _____

EQUIPMENT MODEL NO. _____

EQUIPMENT SERIAL NO. _____

VOLTAGE: (check one) 120 208 240



APW Wyatt • www.apwwyott.com/
265 Hobson St. • Smithville, TN 37166
Telephone: (800) 527-2100

Printed in the U.S.A. • 2M-Z24237 • Rev - (05/21)
Specifications are subject to change without notice.

APW *wyott* is a registered trademark of APW Wyatt®, A Middleby Company. All rights reserved.