

OWNER'S MANUAL

BTL100 & BTL140

HIGH VOLUME PLANETARY MIXER WITH PROGRAMMABLE DIGITAL CONTROL, ELECTRIC BOWL LIFT, STAINLESS STEEL ATTACHMENTS, AND CAPACITY FROM 100 QUARTS (BTL100) TO 140 QUARTS (BTL140).



The technical content of this manual, including any wiring diagrams, schematics, parts breakdown illustrations and/or adjustment procedures, is intended for use by qualified technical personnel and is subject to change without notice.

This appliance is intended to be used for commercial applications, for example, in kitchens of restaurants, canteens, hospitals and in commercial enterprises such as bakeries, butcheries, etc.

INDEX

CHAPTER 2	3
TRANSPORTATION, STORAGE, MOUNTING, INSTALLATION AND CONNECTING	3
2.- TRANSPORTATION	3
2.2.- STORAGE	4
2.3.- ASSEMBLING AND INSTALLATION.....	4
2.4.- CONNECTING AND ELECTRICAL SUPPLY	4
CHAPTER 3	5
MACHINE USAGE	5
3.3.- FUNCTIONING – CONVENTIONAL DIGITAL CONTROL.....	6
3.3.1 – Checking rotation	6
3.3.2 – Bowl lift and descend	7
3.3.3 – Choosing working mode	7
3.3.4 – Working on manual mode	7
3.3.5 – Working on automatic mode.....	7
3.3.5.1 – Changing or setting programmes	7
3.3.5.2 – Running a program	7
3.3.6 – Hub attachment (optional).....	7
3.3.7 – Messages.....	7
3.4.- FUNCTIONING – TOUCH-SCREEN DIGITAL CONTROL.....	8
3.4.1 – Checking rotation	8
3.4.2 – Bowl lift or descend	8
3.4.3 – Choosing work mode	8-10
3.4.4 – Working on manual mode	10
3.4.5 – Working on automatic mode.....	10
3.4.5.1 – Altering or setting program	10
3.4.5.2 – Running a program	11
3.4.6 –Language selection screen	12
3.4.7 – Screen on how to use the machine.....	12
3.4.8 –Sold products screen.....	12
3.4.9 – Maintenance screen	12
3.4.10 – Hub attachment (optional).....	13
3.4.11 – Messages.....	13
3.5.- FAILURE DETECTION AND SOLVING	14
3.6.- PROTECTION MEASURES	14
3.7.- ACCESSORIES AND TOOLS	14
3.8.- MACHINE STABILITY	14
CHAPTER 4	15
PROPERTIES OF THE MACHINE	15
4.1.- MECHANICAL PROPERTIES	15
4.2.- ELECTRICAL PROPERTIES	15
4.3.- MACHINE CAPACITY	15
4.4.- SECURITY SYSTEM	15
4.5.- PRECAUTION WITH TOOLS.....	15
4.6.- PRECAUTION WITH BELTS	15
4.7.- NOISE EMISSION.....	15
4.8.- RADIATION EMISSION.....	15
4.9.- LIFE CYCLE OF THE PRODUCT	15
CHAPTER 5	16
MAINTENANCE	16
5.- WHEN THE MACHINE IS NEW	16
5.2.- EVERYDAY	16
5.2.1.- Machine cleaning	16
5.2.2.- SECURITY SYSTEM CHECK	16
5.3.- EVERY SIX MONTHS.....	17
5.3.1.- Belts check.....	17
5.3.2.- Tools check	17
5.3.3- General tuning and lubrication check	17
5.3.4.- Machine fixation check.....	17
WARRANTY.....	19

**CHAPTER 2
TRANSPORTATION, STORAGE, MOUNTING, INSTALLATION AND
CONNECTING**

The incorrect transportation, storage, mounting, installation or connection of this machine by the client or representative may cause material, people, property or animal damage, the manufacturer not being held responsible for this.

2.1.- TRANSPORTATION

Always use an adequate transportation device regarding the weight on the nameplate.

Always act in compliance with the current laws in your country. The ignorance of such laws does not justify non-compliance.

The machine must be transported according to the following images, with a freight elevator, adequate cables, ropes, chains or hooks. In case of manual handling the risk of the machine over-sliding or sliding in an unexpected direction, must be taken into account.

Regularly check the package for damage subsequent to transportation. In case of damage suspicion, please contact the supplier for examination or record the event so as to later describe the situation.

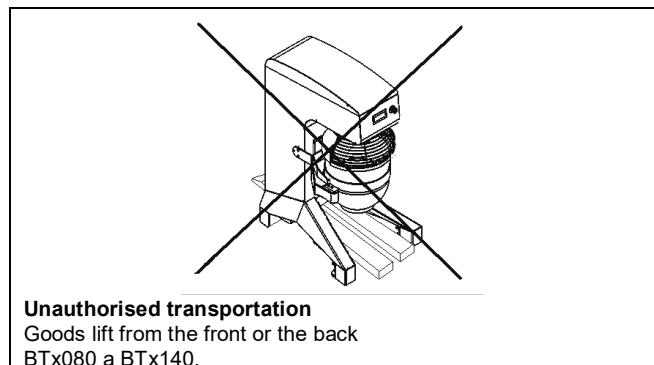
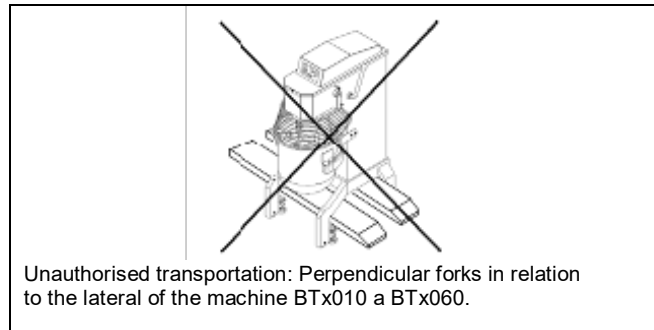
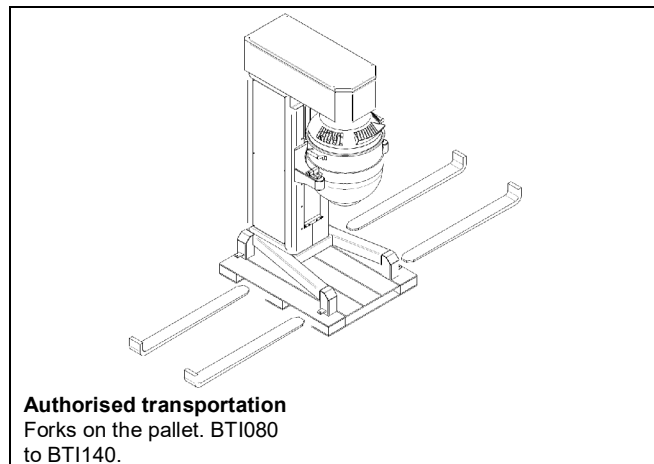
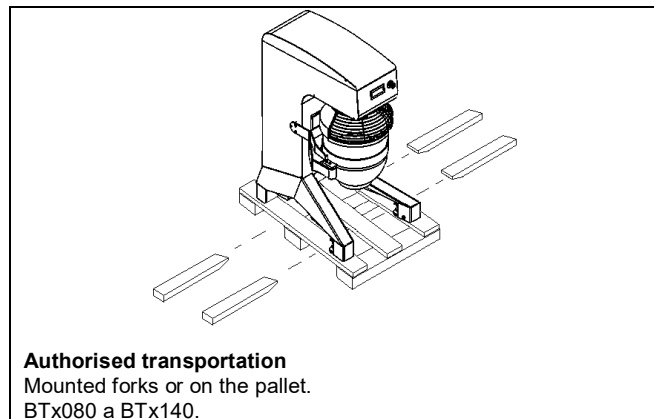
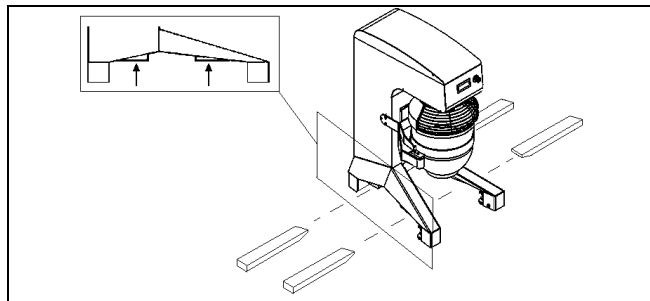
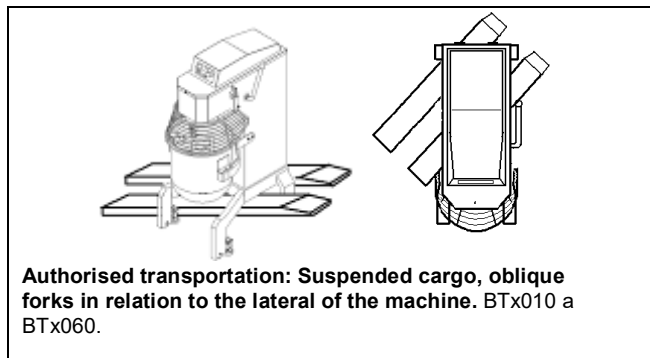
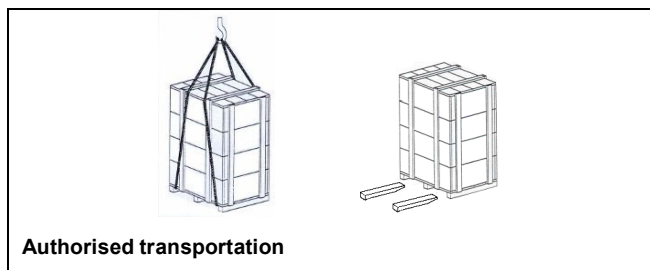

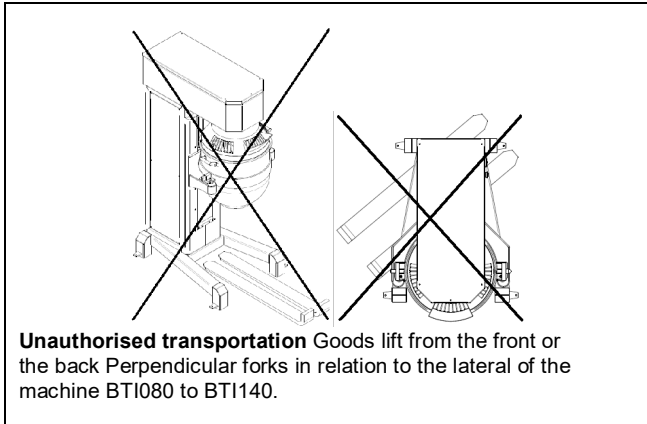

2.2.- STORAGE

Always use transportation equipment for storage that is adequate to the weight on the nameplate of this machine. The storage site has to hold the same weight, thus ground storage is recommendable, avoiding shelves or elevated storage reduces the risk of machine fall. There is no need for it to be fixed to the ground, however, the pavement must be flat and must not be slippery. The pavement should be free of humidity so as to avoid oxidation on painted chassis machines.

During storage, it is mandatory that the machine is disconnected from electrical power supply, but under not circumstances should it be stored subject to bad weather conditions, it must be kept in conditions similar to the work place.

2.3.- ASSEMBLING AND INSTALLATION

<p>CAUTION</p>	<p>During assembling and installation at the work place, make sure the power supply cable is disconnected from the socket. This should be performed by duly accredited personnel by the manufacturer.</p>
-----------------------	--

By the operating place of the machine, remove all packaging, such as cardboard, plastic, pallets, protection wood, film and others. At the exact work place, the machine must be levelled by mounting the anti-vibration pads as in the following picture.

All the supports of this machine must be adjusted to the floor.

<p>CAUTION</p>	<p>Model BTF010</p>
<p>Anti-vibration pads</p>	

	<p>Never run the machine without its complete installation.</p>
--	--

The pavement must be made of concrete, able to endure the weight of the machine and the load for which it is set, in compliance with the properties

on the nameplate of the machine. The pavement must be of a single flat ballast, not containing amendments between the supports of the machine and having a maximum inclination of 0,5%. Anti-vibratory supports must be readjusted, whenever necessary. Make sure no sand or other residue remain between the supports of the machine and the pavement so as to avoid false grips, oscillation or inconvenient noises.

The trolley, optional equipment, is built to facilitate its placing and removal on the machine.

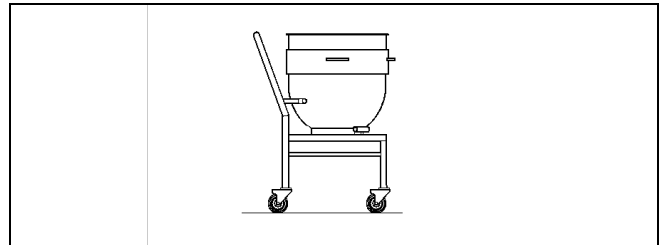

2.4.- CONNECTING AND ELECTRICAL SUPPLY

<p>CAUTION</p>	<p>Any intervention to the equipment must be made after the electrical supply cable has been disconnected, however, when working without power is not possible for technical reasons, duly precautions to reduce the risk of electrical shocks and short-circuits must be taken.</p>
-----------------------	---

This intervention must be performed by a duly accredited technician. Electrical connection must be made by means of a plug or junction box connectors, from a "neutral TT" line, with a 300mA differential protection.

The electrical power available must comply with the specifications of the properties on the nameplate of the machine. Mending supply cables is not allowed.

Power strips for phase reversal, 3D power sockets or other adaptation systems are not allowed.

More than one machine connected to the same power source (socket or derivation) is not allowed.

It is necessary to perform an equipotential bonding between machines that share a ferruled ground wire supplementary connection, of a section of at least 6 mm², connected to the exterior screw of this machine identified by the symbol ⊕

CHAPTER 3

MACHINE USAGE

3.1.- MACHINE CONTROL PANEL

This machine is equipped with a technologically developed control system which controls engines and other electrical equipments. For the machine to run, the following conditions must be respected: Closed grid; emergency button unlocked and main switch on.

	<p>ATTENTION: Control must be performed with a finger. The use of hard or sharp objects may cause unreparable damage.</p>
---	--

There are 3 control options. Check which applies to your machine.

3.1.1 – Conventional digital control

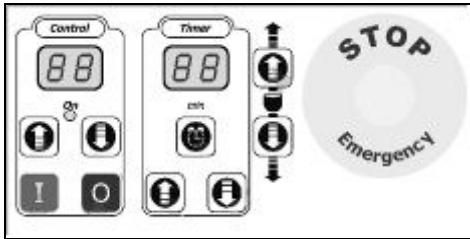

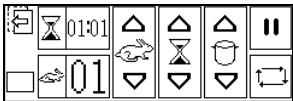

Models BTx010 to BTx060; BTL100 to BTL140.

3.1.2 – Touch-screen digital touch-screen (OPTIONAL)



3.1.3 – Emergency stop

	<p>In case of emergency press the emergency button.</p>	
---	--	---

The emergency button must be pressed only when there is the need to stop the machine abruptly, in case of suspicion of damage to the machine, hazard to people's, property's or animals' safety. Do not use this button to stop work under regular conditions, use the stop button, so all information regarding counting and figures can be screened and accessed.

3.1.4 - Ingredient feeding

Open the security grid (if applicable);
Proceed with the cleaning operation in accordance with the chapter on daily maintenance in this manual;
Loading ingredients into the bowl may be performed while it is on work position or while the trolley is detached from the machine (*):
Make sure the wheels of the trolley (*) are blocked (*) during the placing of ingredients.

	<p>Attention: the trolley (*) offers a mechanical residual risk. While loading ingredients lock (*) the wheels; While manoeuvring, make sure people's, property's or animal's safety is assured.</p>
---	---

(*) If the machine is equipped with this option.

Load the ingredients into the bowl:
The feeding of ingredients and the use of adequate hydrant percentages are two very important factors in the fabrication process, as the performance of the machine may depend on these. Good practices must be followed so as not to overwork this machine.

	<p>Attention: closing the grid (if applicable) and upper the bowl offers a residual risk of jamming upper body members. Make sure nothing interferes with the closing of the grid and the upper of the bowl.</p>
---	---

Place the bowl in the machine: Place a tool as in the following picture:

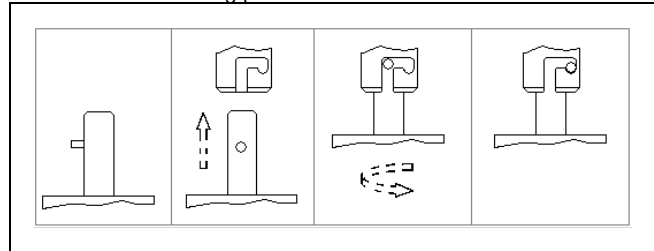

When applicable, mount the scrapper tool as in the following pictures:

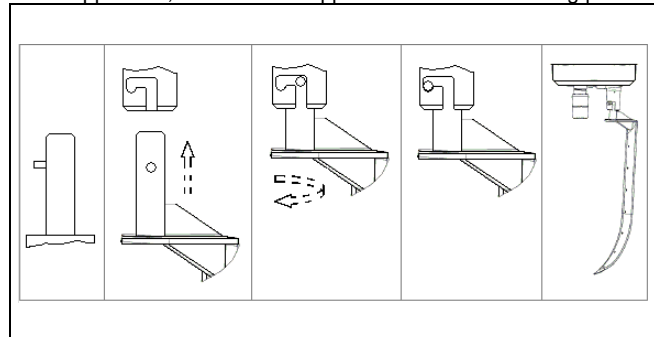

Place the ingredients: Lift the bowl as described further ahead.

	<p>Tools must not be operated before the bowl has been set on the machine. If such happens, it is to be considered inappropriate, wrong or irrational usage of the machine.</p>
---	--

Having the safety grid closed;

Select the intended function on the control.

3.3.- FUNCTIONING – CONVENTIONAL DIGITAL CONTROL

3.3.1 – Checking rotation

This is only applicable to machines which are equipped with the option of bowl electrical lifting and three-phase power supply. Power the machine according to the specifications on the nameplate; Make sure the grid is closed (If applicable), the bowl is in the upper position, the tool at work position and the emergency button is unlocked;

Turn the main switch of the machine on;

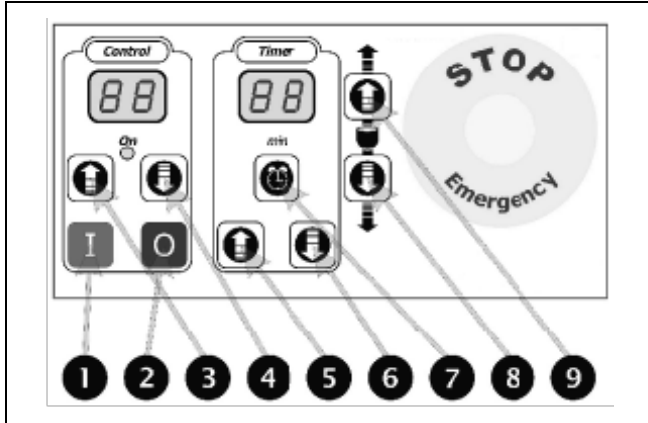

- Button to start the machine
- Button to stop the machine
- Button to increase speed
- Button to decrease speed
- Button to increase work time
- Button to decrease work time
- Programming button
- Bowl electrical descending button (optional button)
- Bowl electrical lifting button (optional button)

Display "On" Operating indication

Display "Control" 1 to 20 speed indication

Display "Timer" 0 to 99 minutes working time indication.

Whatever the position of the power supply phases, the tool always works in the correct rotation direction. However, the bowl electrical lifting may not work properly.

To detect phase sequence there is a protection electronic device to its internal components that prevents possible phase failure or possible phase sequence failure from affecting power supply that may cause damage, sometimes irreparable

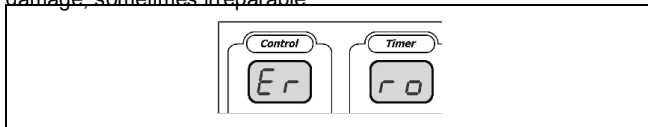

If this message is screened the machine will not continue operating. Thus there is no risk of failure. Switch off power and check all phases are reaching the machine. Re-establish continuity in case of failure. If necessary, switch the position of two phases.

3.3.2 – Bowl lift and descend

To lift or descend the bowl the machine must not be operating. To lift the bowl the tool must be mounted on the machine.

To descend the bowl, the tool may already be in position to exit the head of the machine.

CAUTION

	<p>Attention: there is the residual risk of jamming or crushing on the bowl area at the end of the lifting.</p>
--	--

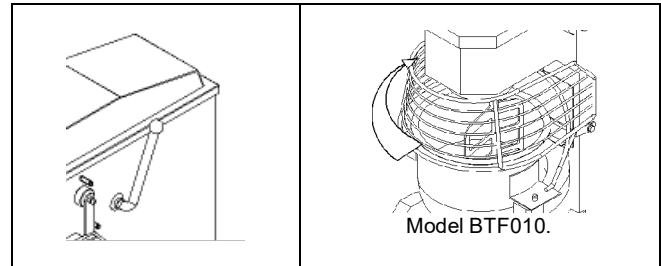

All BTL Mixers are equipped with the electrical lift and descend, hold button "8" or "9" pressed, as needed.

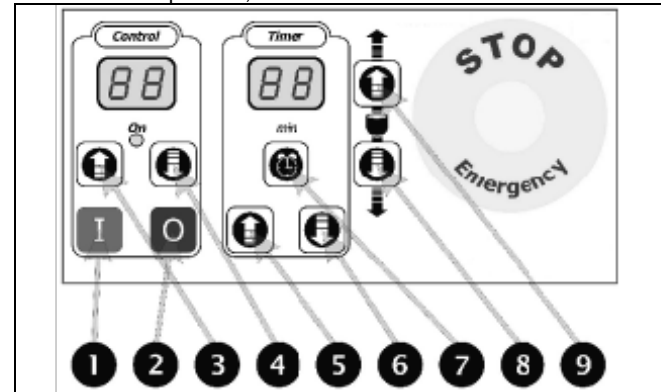

3.3.3 – Choosing working mode

Whatever your option, select the adequate speed for the product so as to prevent the risk of excessive dust production;

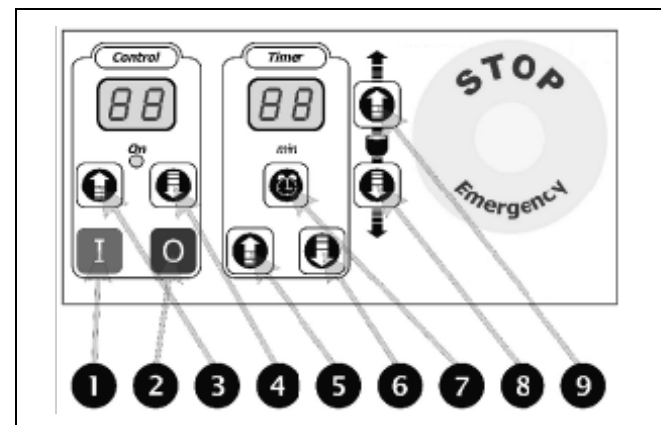

From manual to automatic mode

After switching the machine on, press button "7".

To enter programming mode

Hold button "7" pressed.

From automatic to manual mode

Press button "7"

From programming to manual mode

Hold button "7" pressed.

Selecting language

Not applicable to this control. **3.3.4**

– Working on manual mode

This working mode implies time control must be made by the user. It is necessary for the safety grid to be closed (If applicable), the emergency button unlocked and the bowl and tool in work position; "Timer" display must screen " _ _ ". Otherwise, press button "7" repeatedly until it screens " _ _ ".

Screening time

Time on display "Timer" goes up to 99 minutes.

Speed adjusting

While the machine is operating press "3" or "4" to adjust speed. There are 20 available speeds.

Suspending machine work

Press button "2"

Resuming work

Press button "1"

Stopping work

Press button "2" once again.

3.3.5 – Working on automatic mode

This mode implies time control may be set by the user.

It is necessary for the safety grid to be closed (If applicable), the bowl is in the upper position, the tool at work position, and the emergency button unlocked;

3.3.5.1 – Changing or setting programmes

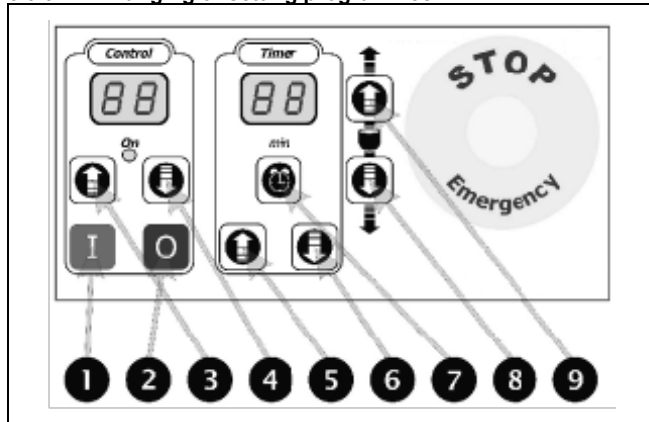

Press button "7" repeatedly to check the existent programmes. The saved programmes are screened on display "Control" and on display "Timer".

8 pairs of «speed-time» figures are stored on the memory, 7 of which are available for changing.

Each speed and time pair can be changed by pressing keys 3, 4, 5 e 6. In the end hold button "7" pressed for 3 seconds to save and exit.

3.3.5.2 – Running a program

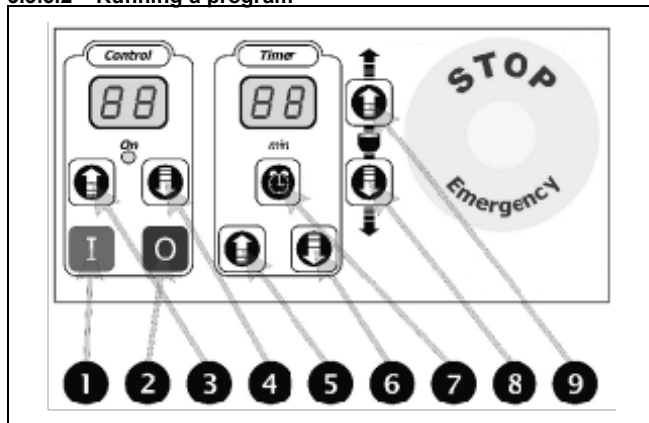

Press button "7" to select the programme.

Activate the start on button "1".

Screening time

Time on display "Timer" decreases to zero.

Pausing work of the machine

Open safety grid (If applicable).

Resuming work

Press button "1"

Stopping work

Press button "2"

3.3.6 – Hub attachment (optional)

CAUTION



Attention: There is a residual risk of jamming upper body members. Make sure nothing interferes with the hub attachment work.

Turn the main switch of the machine ON;
Press button "6" or "7".

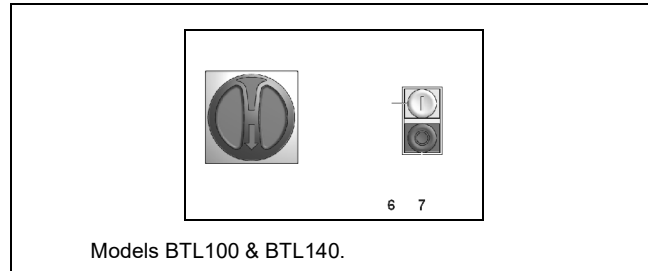

Models BTL100 & BTL140.

Hub attachment start control button.
Hub attachment stop control button.

3.3.7 – Messages

There are messages to support the user, which do not stand for a failure. They come on display Control and Timer as such:

CAUTION



In case of emergency press the emergency button.



Message on Screen	Cause
-------------------	-------

<p>OPEn</p>	<p>On Manual Mode (MM) or Automatic Mode (AM): Safety grid open (If applicable). Bowl down.</p>
--------------------	---

At machine failure situations, an error message may come up on the control screen. Whether the message is screened or not, before contacting accredited by the manufacturer Technical Support, replacing any component or proceeding with operation, switch off the machine on the main switch and unplug the cable from the electrical supply. Hold for about 5 minutes and switch it on again. If the problem has been due to an ephemeral cause, it will go away. Next are some possible failures and eventual solution.

<p>Erro</p>	<p>Thermal relay protection activated. Effort of the machine, by activation of engine thermal protection, caused either by effort of kneading harder dough or by friction. Turn the machine off on the main switch. Reduce the load in the machine. Switch on the machine and resume work. Checking rotation (3.3.1)</p>
--------------------	--

3.4.- USING THE TOUCH-SCREEN DIGITAL CONTROL (OPTIONAL)

3.4.1 – Checking rotation

This is applicable only to machines which are equipped with bowl electrical lift and three-phase powering.

Power the machine according to the specifications on the nameplate. Make sure the grid is closed (if applicable), the bowl is in the upper position, the tool at work position and the emergency button unlocked; Turn the main switch of the machine on; Whatever the position of the powering phases, the tool always works in the correct rotation direction.

However, if the machine is equipped with electrical elevation of the bowl (optional function) it may not work correctly. To detect phase sequence there is a protection electronic device to its internal components that prevents possible phase failure or possible phase sequence failure from affecting power supply that may cause damage, sometimes irreparable.

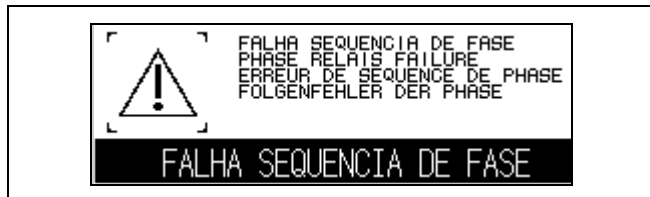

If this message is screened the machine will not continue operating. Thus there is no risk of failure. Switch off power and check all phases are reaching the machine. Re-establish continuity in case of failure. If necessary, switch the position of two phases. Reconnect everything, as described above, for thus the machine shall have the correct phases and the message will go away. The logotype should be screened, as generically presented below:

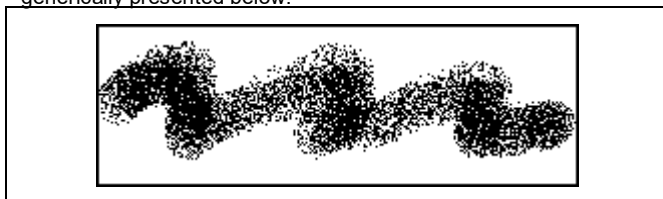

Immediately and automatically, the next screen will come up as it is a manual mode screen. This sequence means the machine has had a correct start and is ready to initiate work.

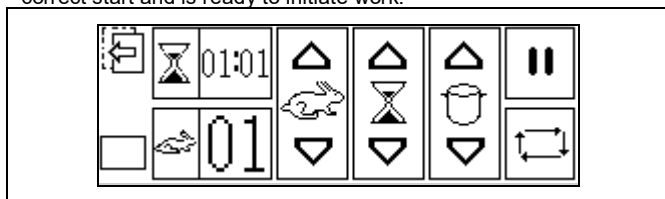

3.4.2 – Bowl lift or descend

To lift or descend the bowl the machine must not be operating.

To lift the bowl the tool must be mounted on the machine.

To descend the bowl the tool may already be in position to exit the head of the machine.

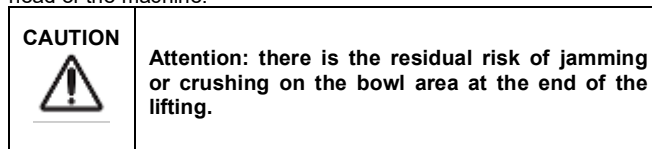

To utilize the electrical lift and descend, hold button "8" or "9" pressed, as needed, otherwise activate the lever on the right side of the machine.

Working on manual mode

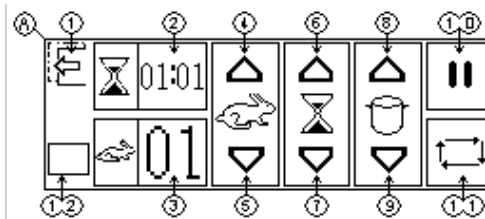

Or working on automatic mode

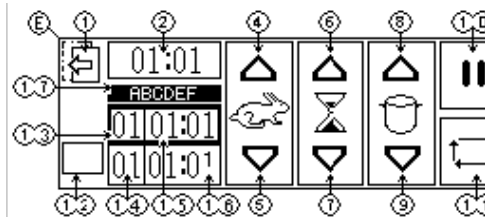

Should you intend to remove the bowl from the machine to transport it on the trolley (*), place the trolley underneath and hold "9" pressed. When the bowl reaches the lower position it will automatically stop. Should you try to operate activating button "11" while the bowl is lowered, the following will be screened.

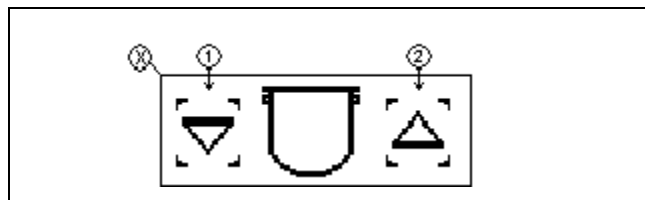

If the machine is equipped with electrical lift or descend, hold button "2" pressed to lift, otherwise activate the lever on the right side of the machine. At the end of the lift it will automatically stop.

This screen will automatically change to work screen when the bowl reaches top position.

(*) If the machine is equipped with this option.

3.4.3 – Choosing work mode

Whatever your option, select the adequate speed for the product so as to prevent the risk of excessive dust production;

From manual to automatic mode

On manual mode, while the machine is stopped, press button "1" on the following screen.

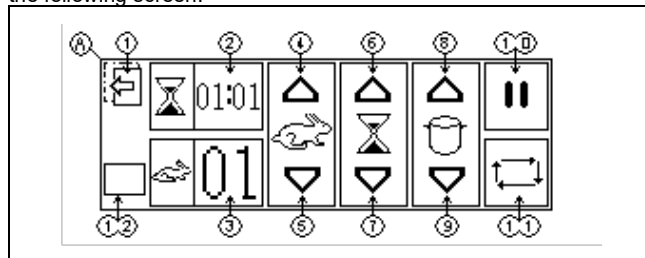

On the programme selection screen, press the programme to be ran on zone "4", to change to automatic mode.

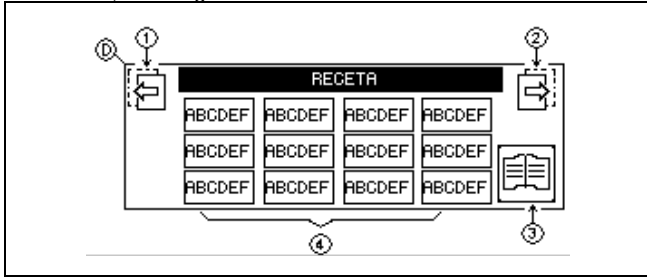

On the following screen, automatic mode, "ABCDEF" is the chosen name on the programme screen.

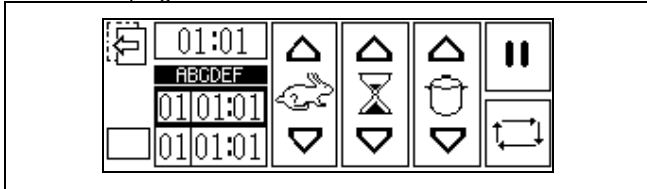

Enter programming mode

On manual mode, while the machine is stopped, press button "1"

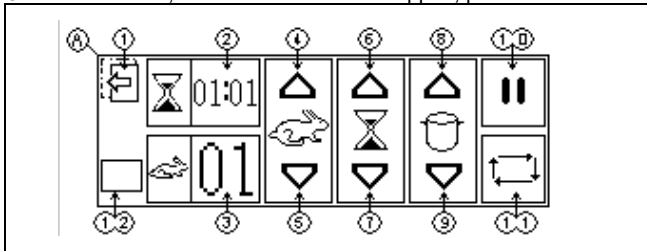

On the following screen to select a programme choose button "3".

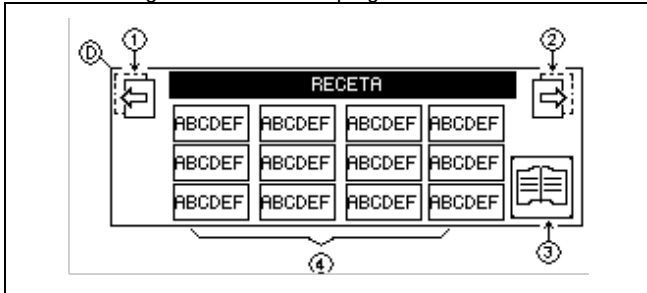

This next programme is for recipe editing on programming mode. There are 4 screens such as this recipe editing. To access press Button "8" forward and button "1" backwards.

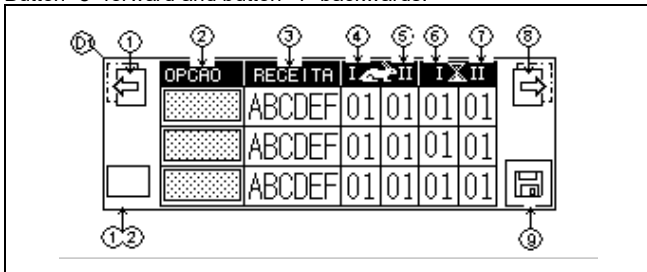

From automatic to manual mode

Having the machine stopped, press button "1"

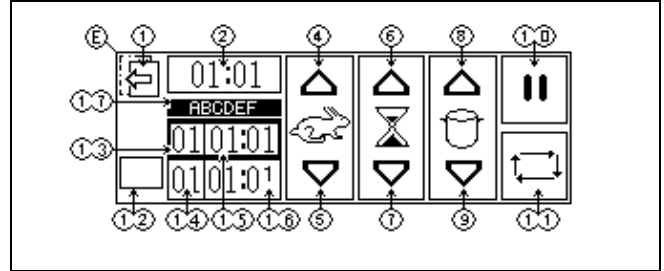

Press the next button "1" on the programme selection screen.

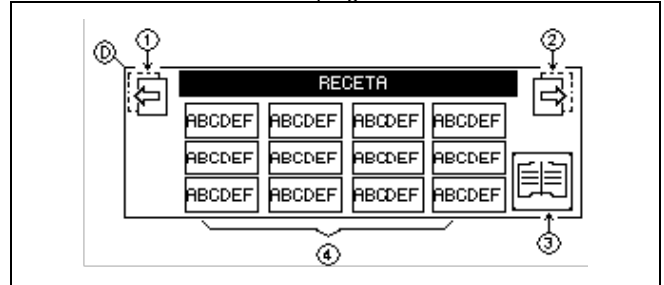

Manual mode screen:

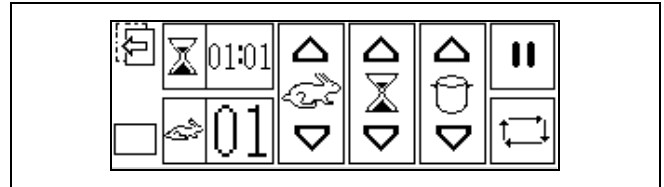

From programming to manual mode

Press button "1" until programme selection is screened.

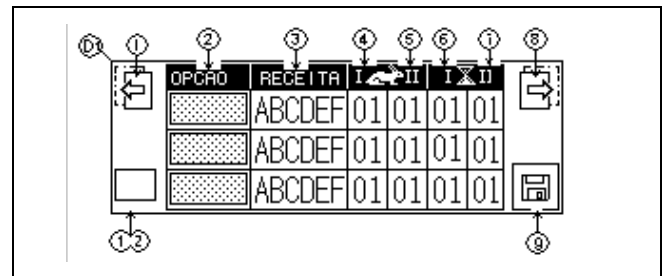

Press the next button "1" on the programme selection screen.

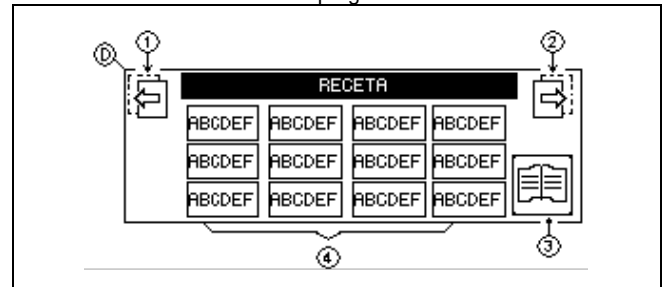

Manual mode screen:

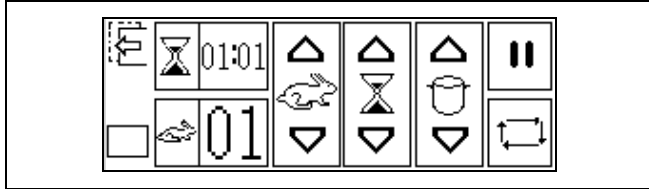

Switching off the machine
While the machine is stopped;
Turn off the main switch.

3.4.4 – Working on manual mode

This working mode means time control must be made by the user. It is necessary for the safety grid to be closed (if applicable), the emergency button unlocked and the bowl and tool in work position;

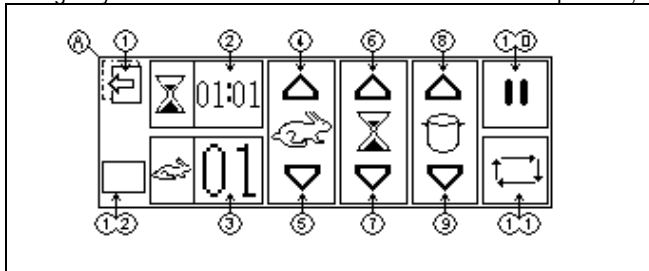

- Automatic screen access button.
- Time screening display, “minutes:seconds” format, increase in seconds, adjust every 30.
- Speed scale display, 1 unit increase, adjust from “01” to “20”.
- Speed increase button shown in .
- Speed decrease button shown in .
- Time increase button shown in .
- Time decrease button shown in .
- Bowl support lift control button (optional function).
- Bowl support descend control button (optional function).
- Work “pause” control button.

Work start control button according to time set in and speed set in .
Identification logotype area.

Adjust “2” for the intended figure; Adjust “3” for the intended figure;
Press “11”;
This procedure runs the machine on manual mode.

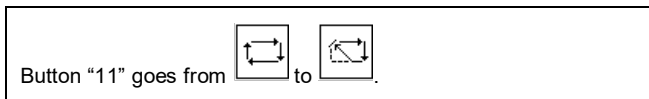

If “3” has been adjusted to “00” the record in “2” is ascendant;
In this case the machine will stop when button “10” or “11” is activated or 99 minutes later.
If “3” has been adjusted to another figure, the record in “2” decreases;
In this case, the machine will stop after the set time.

Suspending the work of the machine
At any moment, at any speed, press “10”, or;
Lift the safety grid (if applicable).

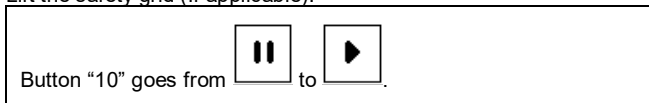

Resuming work
The grid must be closed (if applicable);
Press “10”;



Stopping work

If “3” has been adjusted to “00” the machine will stop when button “10” or “11” is activated or 99 minutes later. If “3” has been adjusted to another figure, the machine will stop at the end of the set time.

At any moment, while the machine is operating, press “11”.



Figures in “2” and “3” go back to start, as before the machine started operating.

3.4.5 – Working on automatic mode

This work mode means time may be programmed by the user. It is necessary for the safety grid to be closed (if applicable), the bowl is in the upper position, the tool at work position and the emergency button unlocked;

3.4.5.1 – Altering or setting programmes

Entering programming mode

The following is programme selection screen.

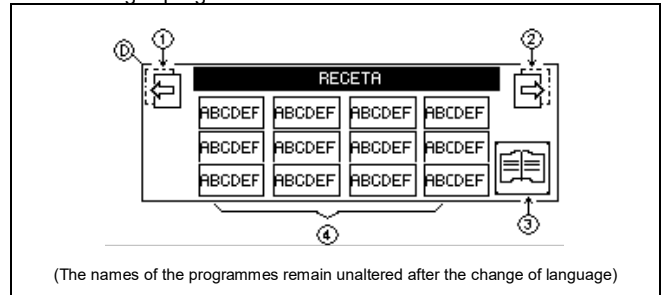

(The names of the programmes remain unaltered after the change of language)

- Manual screen access button.
- Language selection access button.
- Programme editing, screen D1, access button.
- Existent programmes list. To select a programme to run simply press the name of the intended programme to change to automatic mode.

Altering or setting programmes screen:

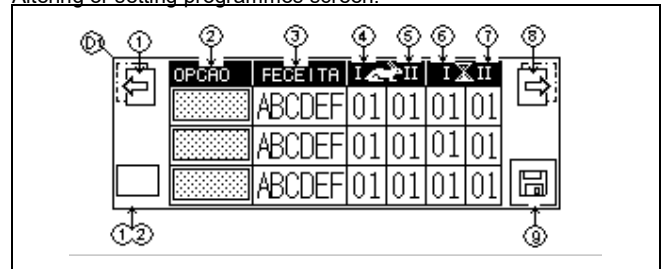

- Programme screen access button.
- List to choose the programme to run.
By pressing a line, the programme automatically changes to automatic mode.
- Programmes list. To edit each name press the intended to change to the following screen:
The blank area screens the written text.
“A” to “Z” available buttons.
Button “CLR” exits the screen without saving and automatically resumes the programming screen.
Button “ENT” saves, exits this screen and automatically returns to the programming screen.
- First speed to be run list.
To edit each speed, press on the intended to change to the following screen:

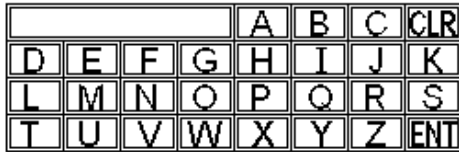

Programme screen access button.
 List to choose the programme to run.
 By pressing a line, the programme automatically changes to automatic mode.
 Programmes list. To edit each name press the intended to change to the following screen:

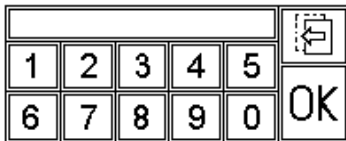

The blank area screens the written numbers. "0" to "9" available numbers.

Button " " exits the screen without saving and automatically resumes the programming screen.
 Button "OK" saves, exits the screen and automatically resumes the programming screen.

Second speed to run list. To edit each speed, press on the intended to change to the following screen: The blank area screens the written numbers. "0" to "9" available numbers. Button " " exits the screen without saving and automatically resumes the programming screen. Button "OK" saves, exits the screen and automatically resumes the programming screen.

First speed to be run list. To edit each time, press on the intended to change to the following screen: The blank area screens the written numbers. "0" to "9" available numbers. Button " " exits the screen without saving and automatically resumes the programming screen. Button "OK" saves, exits the screen and automatically resumes the programming screen.

Second speed to run list. To edit each speed, press on the intended to change to the following screen: The blank area screens the written numbers. "0" to "9" available numbers. Button " " exits the screen without saving and automatically resumes the programming screen. Button "OK" saves, exits the screen and automatically resumes the programming screen.

Control Button to access the last programme editing screen. There are 4 programme editing screens.
 Button to save made changes.
 Identification logotype area.

3.4.5.2 – Running a programme

Saved programme

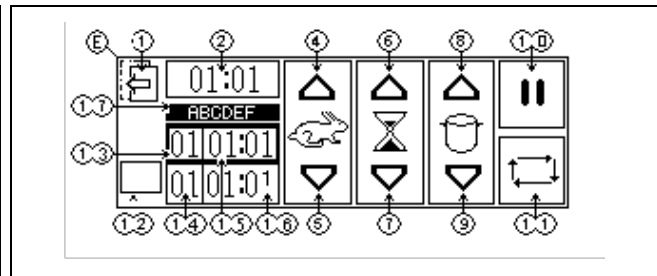
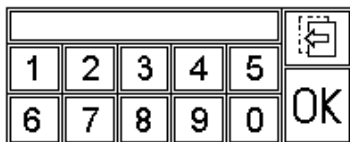

Programme selection screen access button.
 Work time display. The sum of and .
 Increase speed screened in or control button.
 Decrease speed screened in or control button.
 Increase time screened in or control button.
 Decrease time screened in or control button.
 Bowl lift control button.
 Bowl descend control.
 Work "pause" function control button.
 Work "start" function on time set in and speed set in control button.
 Identification logotype area.
 First speed to run display. "01" to "20" speed scale increase by 1 unit.
 Second speed to run display. "01" to "20" speed scale increase by 1 unit.
 First speed time screening display, "minutes:seconds" format, increase in seconds, adjust every 30.
 Second speed time screening display, "minutes:seconds" format, increase in seconds, adjust every 30.
 Saved programme to be ran.

It is necessary for the safety grid to be closed (If applicable), the bowl is in the upper position, the tool at work position and the emergency button unlocked;

Press "11";
 This procedure starts the machine in automatic mode.

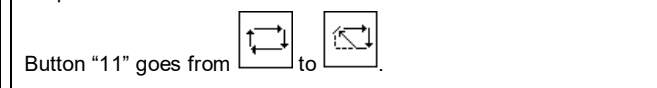

The machine starts work on speed "13".
 At the end of time "15" the machine changes to speed set in "14" and will work for the time set in "16".
 The record in "2" decreases;
 The machine will stop at the end of the time set in
 At any moment during work speed and time may be adjusted by activating buttons "4", "5", "6" or "7".
 If the programme to be ran is "00" on "15";
 The machine will start operating at speed "14" and time "16".
 At the end of this time the machine automatically stops.
 If the programme to be ran is "00" on "16";
 After working at speed 13 and time 15 the machine will automatically stop.

Pausing the work of the machine

At any moment, at any speed, press "10", or;
 Lift the safety grid (If applicable);

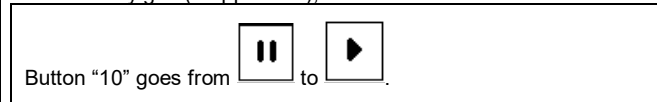

Resuming work

The grid must be closed (If applicable), the bowl is in the upper position, the tool at work position;
 Press "10";

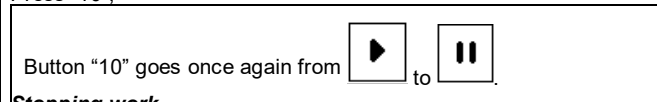

Stopping work

At any moment, while the machine is operating, press "11".



Figures in "13", "14", "15" and "16" go back to start, as before the machine started. Changes during programme running will not be saved.

3.4.6 –Language selection screen

On the language selection screen, button "2" accesses the language selection screen.

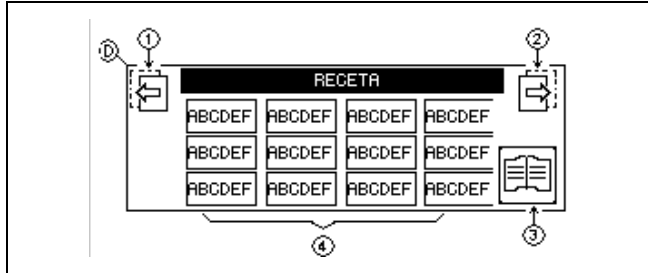

The following is the language selection screen:

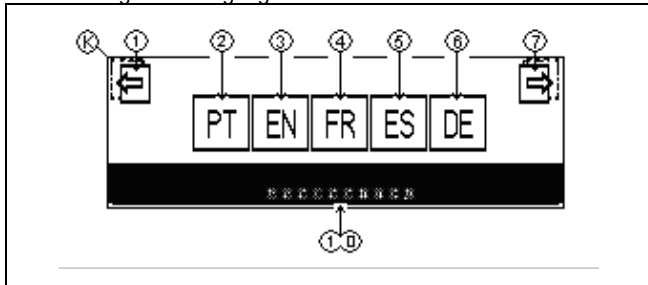

When keys , , , or are activated the selected language is screened shaded. The software version or the screen on how to use the machine can be accessed.

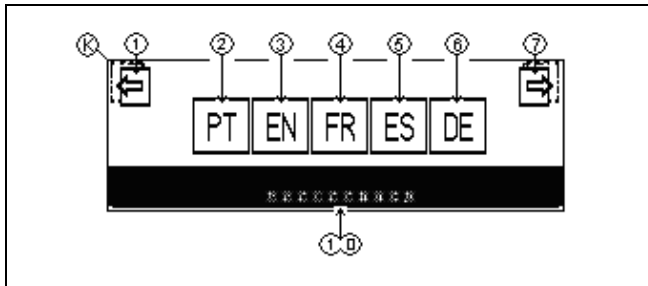

- Automatic mode access button.
- Portuguese selection button.
- English selection button. □ French selection button. □
- Spanish selection button. □ German selection button.
- Screen on how to use the machine access button.
- Software version of the machine display.

3.4.7 – Screen on how to use the machine

On the language selection screen press button "7".

- Resume to language screen.
- Product disclosure screen access.
- Short explanation text on how to start the machine.

3.4.8 –Sold products screen

On the how to use the equipment screen, press button "2" to change to the screen on available products.

How to use screen is the following:

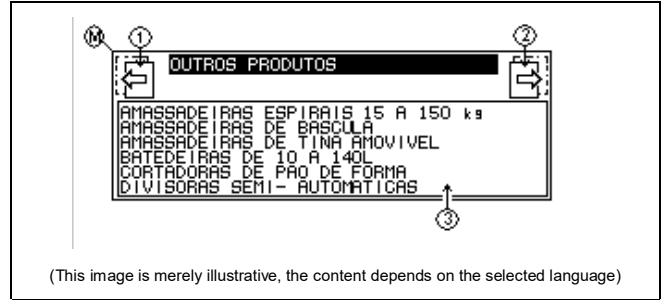
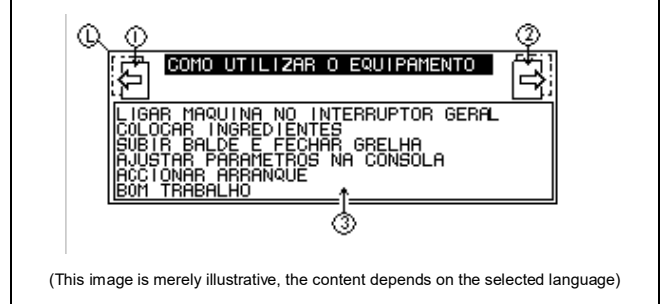

Button "2" provides access to the second screen on available products.

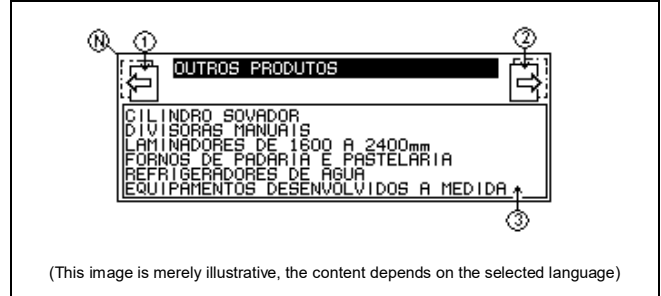

Button "2" from the previous screen offers access to the maintenance screen (subject to password: "****").

3.4.9 – Maintenance screen

The second screen on available products offers access to the maintenance screen by pressing button "2". Entrance and exit screen.

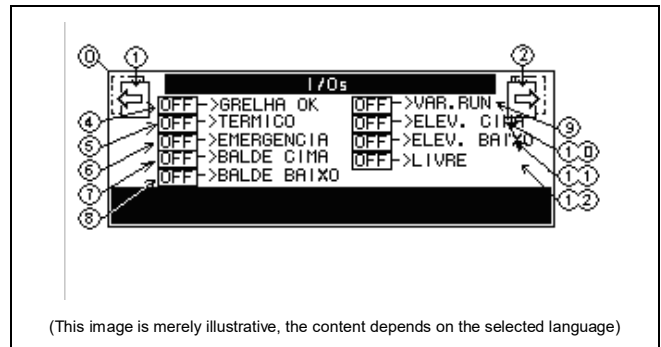

This screen offers access to information concerning entrance and exit to the automaton of the machine. "ON" stands for an active function

"OFF" stands for an inactive function.

Access the screen on which work related information may be obtained as well as information concerning the thermal protection of the machine.

	Access to entrance and exit screen button.
	Button to access screen on products.
	Button to access the second screen on maintenance.
	Display of the state of the safety grid (If applicable).
	Display of the state of the thermal of the variator.
	Display of the state of the emergency button.
	Display of the state of the bowl support above.
	Display of the state of the bowl support below.
	Display of the state on "RUN" of the variator.

Button "2" offers access to the following Counters screen

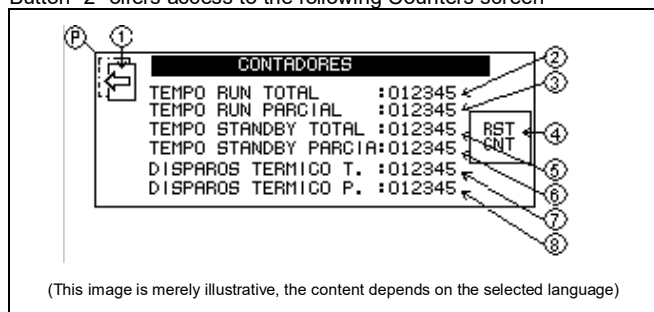

	Display of the total amount of time on "RUN" of the variator.
	Display of a partial amount of time on "RUN" of the variator.
	Access to counters reset screen button (subject to password: "*****").
	Display of the total amount of time on "STANDBY" of the variator.
	Display of a partial amount of time on "STANDBY" of the variator.

3.4.10 – Hub attachment (optional)

CAUTION 	Attention: There is a residual risk of jamming upper body members. Make sure nothing interferes with the hub attachment work.
--------------------	--

CAUTION 	In case of emergency press the emergency button.	
--------------------	---	--

3.4.11 – Messages

During the operating of the machine there are messages to the

Message	Description	What to do
(This image is merely illustrative, the content will depend on the selected language)	Safety grid open (If applicable)	Regular use, close grid if necessary
	Safety grid closed (If applicable)	Tune or replace the end of course
 (This image is merely illustrative, the content will depend on the selected language)	Emergency button pressed	Unlock emergency button if necessary
	Emergency button unlocked	Check connections or replace button
(This image is merely illustrative, the content will depend on the selected language)	Trigger of the engine thermal protection, caused by effort of working with harder dough; or by friction.	Reduce the load of the machine. Try to repeat the work. Should it repeat, contact accredited by the manufacturer
 (This image is merely illustrative, the content will depend on the selected language)	Without bowl; Bowl out of the work position; Lowered Bowl	Put the bowl at work position or/and Lift bowl
	Bowl lifted	Tune or replace the end of course
		Technical Support.

At machine failure situations, before contacting accredited by the manufacturer Technical Support, replacing any component or proceeding with operation, switch off the machine on the main witch and unplug the cable from the electrical supply. Hold for about 5 minutes and switch it on again. If the problem has been due to an ephemeral cause, it will go away.

3.5.- FAILURE DETECTION AND SOLVING

Possible failure – detection	Probable cause	Possible solution
The electronic plaque does not switch on	Non-powered machine	Reconnect to energy supply source
	Main switch off	Turn on main switch
	Jammed emergency button	Turn to unjam button
	Damaged electronic plaque	Replace electronic plaque
	Other electric failure	Request technical support that is accredited by the manufacturer.
A function of the electronic plaque does not work	Damaged electronic plaque	Replace electronic plaque
	Other electric failure	Request technical support that is accredited by the manufacturer.
The machine works, lacks power and makes a strange noise	Mechanical part jam	Request technical support that is accredited by the manufacturer.
	Three-phase engines working in two phases.	Reestablish electrical connection
	The belts slide	Stretch belts
All functions are operating, however, the tool does not rotate	At least one of the engines is damaged or the belts have broken	Request technical support that is accredited by the manufacturer.
Loose tool in the bowl or touching the bowl	Bent tool; fractured; bent bowl or damaged stabilising system of the bowl. Damaged planetary or head of the machine.	
The bowl wiggles too much while simply kneading	Excessive load on the machine.	Relieve machine from load.
The bowl wiggles too much (even when it is empty)	Damaged stabilising system of the bowl.	Request technical support that is accredited by the manufacturer.
Squeak sounding noise	Damaged roller or equipment lacking lubrication	
noise is loud	tool has broken.	manufacturer.
Does not perform electrical lift (optional function)	Electrical system damaged	Request technical support that is accredited by the manufacturer.
The front of the electronic plaque is torn or punctured	Use of pointy or cutting objects	Replace the electronic plaque

3.6.- PROTECTION MEASURES

The user must comply with all the necessary protection measures that apply. Thus, possible dust must be prevented by using a work overall and avoid dough contamination by protecting all capillary body parts. Staring at the dough during work for over thirty seconds is inadvisable, as it may eventually lead to stress, fatigue or temporary loss of balance.

3.7.- ACCESSORIES AND TOOLS

This machine is equipped with the tools and accessories presented below, for usage on the machine. Hub attachment (optional)

Models BTL100 to BTL140.

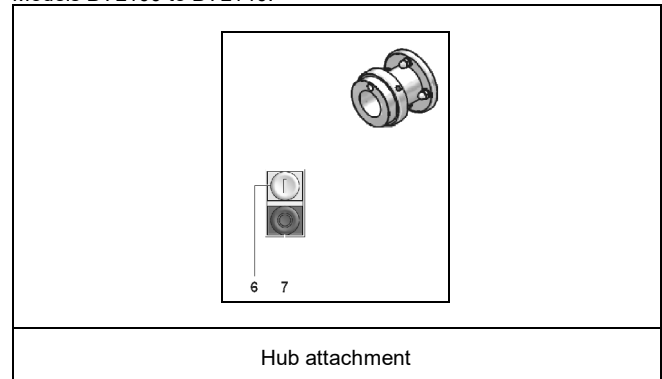

Models BTL100 - BTL140:

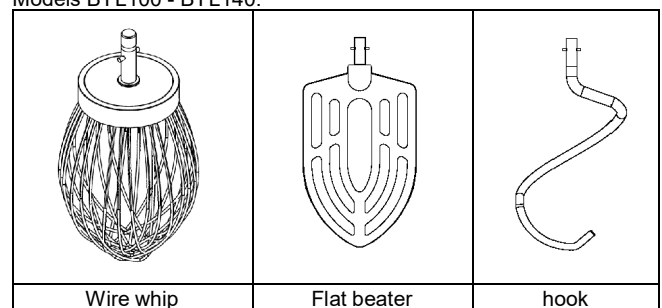

Accessories Models

BTL100 & BTL140:

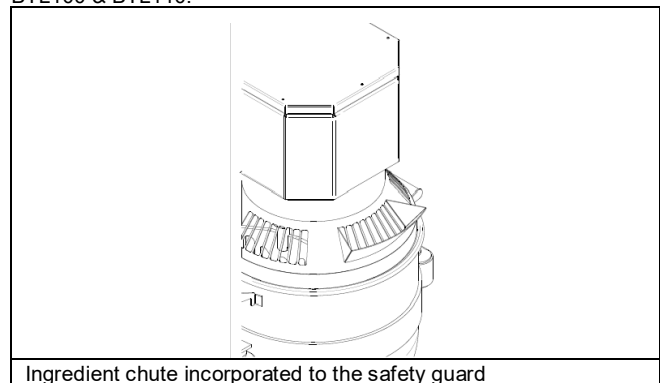

To discharge the product or cut the dough after having been kneaded, prevent scratches to the bowl. The use of metal scrapers or metal accessories is not allowed.

3.8.- MACHINE STABILITY

Conditions under which the machine complies with the stability requisite:

Phases	Conditions
Transportation and mounting	According to the specific information in the chapter on transportation, mounting, installation and connection within this manual.
Usage	According to specific information on assembling in this manual According to specific information in the chapter on maintenance.
Dismounting	On dismounting operations it is mandatory that the machine is on work position.
Out of service	When out of service, the machine must be in working position. The pavement must not be sloping or slippery. The machine does not need to be screwed to the floor.
During testing	When testing load the above described is applicable.

CHAPTER 4

PROPERTIES OF THE MACHINE

4.1.- MECHANICAL PROPERTIES

The structure has standard or special order measures, to match its purpose.

Made of steel, standard physical-chemical or special order characteristics.

The materials that are in straight contact with the dough do not offer any hazard of contamination or change of its properties.

Mechanical transmissions are performed by speed variation belts and analogical or digital control.

4.2.- ELECTRICAL PROPERTIES

This machine has been manufactured according to characteristics on the nameplate.

Check annex to this manual for the electrical scheme. The electrical system has been tested according to the applicable legislation and the test record is part of this manual.

Only Technical Support that is accredited by the manufacturer is qualified to work the electrical part. All necessary precautions must always be taken so as to reduce fire, electrical shocks and personal damage hazard, always in compliance with the following norms:

1. Stopping the machine.
2. Turning off main switch.
3. Disconnecting power cable.
4. Performing the necessary maintenance or repairing operations and only then,
5. Re-switching the machine to the power supply.

4.3.- MACHINE CAPACITY

The maximum capacity of mixers is measured by the maximum capacity of the bowl in terms of litres, that is, a model labelled with the example information of "xxx020" has a 20 litres maximum bowl capacity, this rule being applicable to any model.

4.4.- SECURITY SYSTEM

One of the potentially most dangerous parts of the machine is the tool area.

The user does not need to directly access this area considering it is protected by the grid when operating under regular circumstances.

4.5.- PRECAUTION WITH TOOLS

One of the potentially dangerous areas of the machine is the hook while operating within the bowl. The user does not need to have straight access to this area so it is protected by the grid when standard operating.

4.6.- PRECAUTION WITH BELTS

The user does not need to have straight access to the belts area, as it is not part of the user's regular work. This area is protected by rigid screwed lids.

4.7.- NOISE EMISSION

The use of specific manufacturing techniques sustains an average sound pressure, considered in A, lower than 70dB, in compliance with ISO directive 3744: "Acoustic. Determination of sound power levels of noise sources using sound pressure. Engineering method in an essentially free field over a reflecting plane."

4.8.- RADIATION EMISSION

The machine does not produce any sort of radiation, including ionizing and non-ionizing radiations that may hazard the user's or exposed people's health, including cases involving active or non-active implanted medical devices.

4.9.- LIFE CYCLE OF THE PRODUCT

<p>CAUTION</p> 	<p>Do not place debris of the components of the machine together with domestic waste.</p>
--	--

During the life cycle of the product, whether it is an inspection operation, maintenance or disposal of this machine, the manufacturer is responsible for the treatment of any piece, component or material at any phase. The life cycle management must always be made by the manufacturer, the only to be held responsible for this management if duly informed for it.

This management firstly considers the possible repair and later reuse of any piece, component or material, however, should that not be possible, redirection to duly accredited residue management must be done, always keeping recycling as a priority. Taking this into consideration, the manufacturer shall deliver into the market highly recyclable equipment.

Directives of different countries must always be taken into consideration, each case having to be regarded separately.

This equipment has the recycling symbol. This means all residues must be separated per type and deposited in an adequate place for residue collection, never included in domestic waste. This attitude is environmentally friendly and beneficial to all in present and coming generations.

**CHAPTER 5
MAINTENANCE**

 <p>CAUTION</p>	<p>Turn off the main switch and power cable before each cleaning or maintenance operation.</p>
---	---

Whenever potentially dangerous operations are performed, such as mechanic tunings, maintenance, dismounting, electrical components replacement, mechanical or other type, the user must assure the electrical power cable is correctly unplugged.

The internal mechanical components of the machine may eventually offer some mechanical residual hazard. To handle these components wear adequate protection gloves.

 <p>CAUTION</p>	<p>Do not run the machine until all lids, security devices and protection have been set.</p>
---	---

In case of a request to the manufacturer, please offer the information on the nameplate of the machine. Check the annex for the repairing pieces or maintenance applicable to this machine.

5.1.- WHEN THE MACHINE IS NEW

Proceed to a cleaning operation, as described in the daily cleaning topic of this manual.

Even after the cleaning, it is convenient to test the functioning before starting manufacturing, using ingredients that are not to be consumed by people. Thus, packaging, transportation and installation residues can be removed.

5.2.- EVERYDAY

5.2.1.- Machine cleaning

The machine cleaning frequency must be adjusted according to the work hours and the severity of the product. Following is a suggested cleaning frequency table according to the work load:

Number of 8 hour shifts	Cleaning frequency within 24 hours
1	One cleaning procedure every 24 hours

The machine must be clean after the operation, on the grid, the inside of the bowl and the tools. On models BTx020 to BTx060 the wire whip may be dismantled as in the following pictures, to facilitate the cleaning. Dismounting is simple, before removing the wire whip from the machine manually loose the lid. After the cleaning it must be properly mounted. For the final tightening of the wire whip mount it on the machine and tighten it manually.

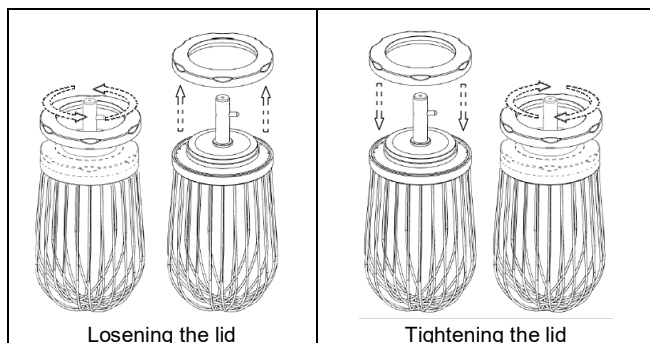

For non-dismounting wire whips cleaning must also be daily.

On these areas, a diluted disinfectant recommended by the manufacturer must be used, followed by abundant rinsing and drying with an absorbent paper or dry cloth.

The water temperature must range between 55°C and 60°C. In the other outer parts of the machine a vacuum cleaner, a slightly wetted cloth or soft sponge may be used, taking care not to cause leakage. In the end proceed to the drying by using dry absorbent paper or cloths.

On the inside of the machine, a vacuum for solid and dusty residues can be used.

 <p>CAUTION</p>	<p>Do not use knives, sandpaper, metallic objects, abrasive, toxic or solvent products, or any other sort that may damage the surface or leave residue that may result in product contamination.</p> <p>Do not use jets of water to clean the machine.</p>
---	--

The materials in contact with the dough are entirely innocuous, they do not affect the product. Following are some merely informative examples of possible hygiene failures after visual inspection or microbiologic analysis, its causes, detection means and its effect and control:

Effect	Cause	Control
Dirt by protein coagulation	The water is too hot, Temperature higher than 60°C	Use water ranging from 55°C to 60°C.
Dirt by grease development	Not too hot water, not so effective in grease elimination Temperature less than 55°C	Use water ranging from 55°C to 60°C.
Dirt with limestone deposit	Too much hard water (>10°FH)	<u>Use less hard water</u>
<u>Dirt accumulation, harder removal</u>	<u>Long intervals between cleanings</u>	<u>Shorter intervals between cleanings or more intense cleaning</u>
<u>Residual dirt</u>	<u>Incorrect rinsing</u>	<u>Rinse well</u>
<u>Initial dirt still visible</u>	<u>The disinfectant did not act for enough time which affected its outcome</u>	<u>Check cleaning procedure</u>
	<u>Too diluted disinfectant</u>	<u>Check disinfectant preparation procedure</u>
	<u>Inappropriate disinfectant</u>	<u>Select correct disinfectant</u>

5.2.2.- SECURITY SYSTEM CHECK

The security systems of the machine assure people, property and animals security under any circumstance. To check the operability of these systems, before the start of each shift, proceed in the following way:

Check if the protection lids are operational. If not, re-establish functionality.

Set the machine to manual mode;

Open the grid entirely (If applicable);

The machine must switch itself off when the grid begins to be open. Should that not happen, turn it off on the main switch and call the technical support of the manufacturer.

If the grid is operational (If applicable), close it and get the machine working again;

Press the emergency button;

The machine must switch itself off and remain as such keeping the emergency button locked. Should this not happen, turn the machine off on the main switch and call the technical support of the manufacturer.

5.3.- EVERY SIX MONTHS

Check frequency according to work load:

Number of 8 hour shifts	Check frequency every 6 months
1	One check on the 6th month

5.3.1.- Belts check

The belts stretching must be performed by a technician who is duly accredited by the manufacturer.

In case of need, depending on the elevation or machine installation, to access the upper-lid area a ladder or other elevation equipment must be used, assuring directives and other current legislation regarding elevation of people is respected.

Should belts need stretching, proceed as follows:

Turn off the main switch of the machine;

Disconnect the power supply cable;

Unfasten the screws on the lid;

Unfasten the engine support screws just slightly.

Stretch the belts until they comply with the following

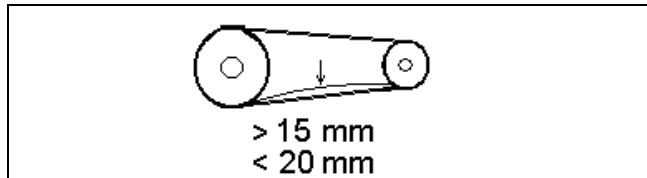

Should a belt be broken, all must be replaced, not simply the one that has been broken. When replacing all belts, use complete sets of the same manufactured series.

Fasten the engine support screws once again.

Re-check the belts and repeat the procedure once again.

Fasten the screws of the lid.

Depending on the usage frequency and effort put upon the machine, this period must be adjusted to what is considered convenient. The higher the usage frequency or effort, the lesser the interval between these checks must be.

5.3.2.- Tools check

Mount a tool on the machine in work position and check if the fitting is loose. Repeat this procedure for all tools. If necessary, request technical assistance accredited by the manufacturer.

5.3.3- General tuning and lubrication check

The bowl rollers adjustment must be performed by a technician who is duly accredited by the manufacturer.

5.3.4.- Machine fixation check

Check the fastening of all the machine fixation screws to the antivibration supports. Adjust if necessary.

CHAPTER 6**ANNEX****6.1.- ELECTRICAL SCHEMES**

(Check the end of this manual)

6.2.- SPARE PARTS

(Check the end of this manual)



LIMITED COMMERCIAL WARRANTY

Two year parts and one year labor limited warranty for USA and Canada only One year limited parts only warranty for All International Markets

This warranty applies to all equipment that has been unaltered, properly installed in a commercial facility, and maintained in accordance with the installation section of the operators manual. Our products are warranted to the original purchaser to be free from defects in material and workmanship for a period of two years from the date of original installation, not to exceed 30 months from the product manufactured date. This warranty does not apply to equipment damaged, abused or altered accidentally or intentionally or modified by unqualified service personnel or with missing or altered serial nameplates. In order to be warranted, the equipment

Doyon/NU-VU agrees to repair or replace defective parts due to flaws in material or workmanship during the warranty period. Labor to repair or replace defective parts shall be warranted when performed by an authorized service agency. Travel over 50 miles, holiday or overtime labor charges are not covered. Proper installation, initial inspection, or normal maintenance such as lubrication, adjustment or calibration is the responsibility of the dealer, owner-user or installing contractor and is not covered by this warranty. This warranty does not cover wear & tear items (lights bulbs, gaskets, nozzles), temperature calibration or defects resulting from handling, abuse, misuse, nor shall it extend to any unit from which the serial number has been removed or altered or the unit is modified in any way, shape, or form by an unauthorized service personnel.

As well our warranty does not covered damaged by flood, fire, or other acts of god. Nor will this warranty apply as regards to the immersion element damage by hard water. Doyon/NU-VU does hereby exclude and shall not be liable to purchaser for any consequential or incidental damages including but not limited to: damages of property, damages for loss of use, loss of time, loss of profits or income that are in direct result of a breach or warranty. Doyon/NU-VU warranty does not apply to residential installation unless agreed to in writing prior to purchase and installation.



NOTE :

Warranty excludes racks, equipment stands and bread cabinets.

These items carry a (1) year limited parts warranty.

Accessories such as mixer tools, etc. are subject to the standard (90) day defective parts warranty.

The above warranty statement is for commercial applications only. Doyon does not warranty items installed in residential spaces without written authorization prior to purchase.

PROUD MEMBER OF





DOYON BAKING
5600 13TH STREET
MENOMINEE, MI 49858
Tel.: 1 (906) 863-4401
US: 1 (800) 338-9886
FAX: 1 (906) 863-6322
<http://www.doyonbaking.com>
SERVICE@DOYONBAKING.COM