

BLODGETT® **BLODGETT**® **BLODGETT**® **BLODGETT**®

BLODGETT® **BLODGETT**® **BLODGETT**®

BLODGETT® **BLODGETT**® **BLODGETT**® **BLODGETT**®

BLODGETT®

900 SERIES
ROASTING, BAKING AND PIZZA OVEN
INSTALLATION - OPERATION - MAINTENANCE



BLODGETT OVEN COMPANY

www.blodgett.com

42 Allen Martin Drive, Essex Junction, VT 05452 USA Telephone: (802) 658-6600 Fax: (802)864-0183

PN 11356 Rev L (11/17)

© 2017 - G.S. Blodgett Corporation

Your Service Agency's Address:

Model

Serial number

Oven installed by

Installation checked by

IMPORTANT

WARNING: Improper installation, adjustment, alternation, service or maintenance can cause property damage, injury or death. Read the installation, operation and maintenance instructions thoroughly before installing or servicing this equipment.

INSTRUCTIONS TO BE FOLLOWED IN THE EVENT THE USER SMELLS GAS MUST BE POSTED IN A PROMINENT LOCATION. This information may be obtained by contacting your local gas supplier.

FOR YOUR SAFETY

Do not store or use gasoline or other flammable vapors or liquids in the vicinity of this or any other appliance.

The information contained in this manual is important for the proper installation, use, and maintenance of this oven. Adherence to these procedures and instructions will result in satisfactory baking results and long, trouble free service. Please read this manual carefully and retain it for future reference.

ERRORS: Descriptive, typographic or pictorial errors are subject to correction. Specifications are subject to change without notice.

TABLE OF CONTENTS

INSTALLATION

Oven Description and Specifications	2
Delivery and Location	4
Oven Assembly	5
Packaging	5
Leg Attachment	5
Caster Attachment	5
Double Section Assembly	6
Ultra Rokite Deck	6
Steam Injection	7
Ventilation	8
Utility Connections - Standards and Codes	10
Gas Connection	11
Gas Piping	11
Pressure Regulation and Testing	12
Gas Hose Restraint	13
Initial Startup	14

OPERATION

Safety Information	15
Oven Control	16
Suggested Times and Temperatures	17

MAINTENANCE

Cleaning and Preventative Maintenance	19
Troubleshooting Guide	20



Installation

Oven Description and Specifications

The 900 Series enjoys the distinction of having the longest continuous production run of any oven manufactured by the G. S. Blodgett Company since its founding in 1848. The first 900 oven was marketed in 1940 and while advancements in metallurgy and more convenient and reliable controls have been incorporated over the years, the basic design of this unit has remained unchanged since its inception.

In establishing this record, the 900 Series has set industry wide standards for excellence in baking characteristics, performance, and reliability. In its primary applications, it remains unsurpassed for product quality. Simplicity of design and quality construction throughout assure years of trouble-free service if equipment is installed properly and given minimal periodic maintenance.

GAS RATINGS				
	Natural Gas		Propane	
	US Units	SI Units	US Units	SI Units
Heating Value	1000 BTU/hr	37.3 MJ/m ³	2550 BTU/hr	95.0 MJ/m ³
Specific Gravity (air=1.0)	0.63	0.63	1.53	1.53
Gas Manifold Pressure	5.0" W.C.	1.25 kPa	10.0" W.C.	2.49 kPa
Oven Input				
901	22,000 BTU	6.4 KW	22,000 BTU	6.4 KW
911	20,000 BTU	5.9 KW	20,000 BTU	5.9 KW
911P	27,000 BTU	7.9 KW	27,000 BTU	7.9 KW
951	38,000 BTU	11.1 KW	38,000 BTU	11.1 KW
961	37,000 BTU	10.8 KW	37,000 BTU	10.8 KW
961P, 966, 981	50,000 BTU	14.6 KW	50,000 BTU	14.6 KW
Main Burner Orifice Size				
901	45 MTD*	2.08 mm	54 MTD*	1.39 mm
911	46 MTD*	2.05 mm	55 MTD*	1.3 mm
911P	42 MTD*	2.35 mm	53 MTD*	1.5 mm
951	34 MTD*	2.8 mm	49 MTD*	1.85 mm
961	34 MTD*	2.8 mm	49 MTD*	1.85 mm
961P, 966, 981	30 MTD*	3.25 mm	45 MTD*	2.1 mm
Pilot Burner Orifice Size	0.18"	.45 mm	.010"	.25 mm
<i>NOTE: * - Multiple Twist Drill</i>				
<i>NOTE: Orifice sizes given are at sea level.</i>				

Oven Description and Specifications

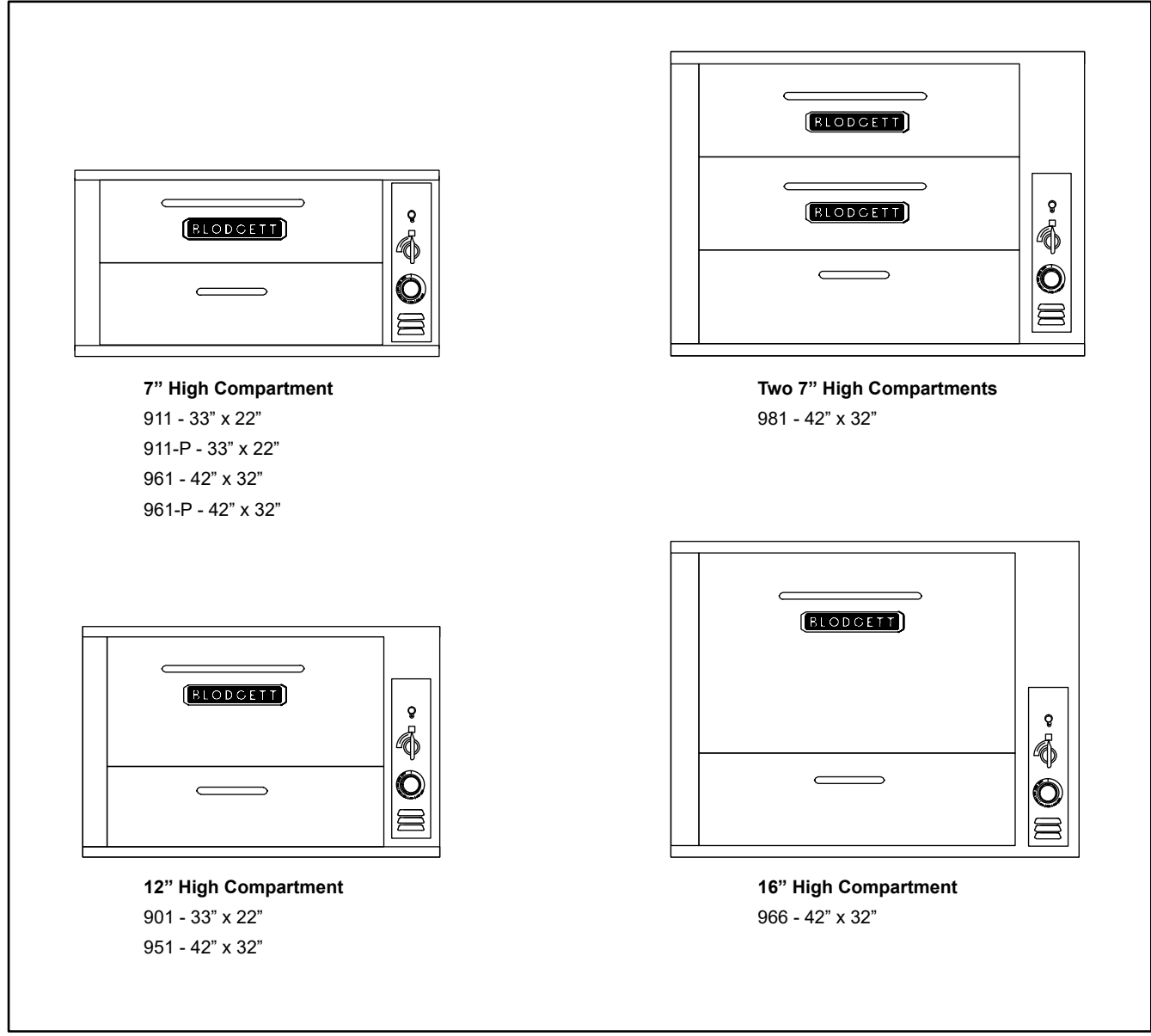

Figure 1



Installation

Delivery and Location

DELIVERY AND INSPECTION

All Blodgett ovens are shipped in containers to prevent damage. Upon delivery of your new oven:

- Inspect the shipping container for external damage. Any evidence of damage should be noted on the delivery receipt which must be signed by the driver.
- Uncrate the oven and check for internal damage. Carriers will accept claims for concealed damage if notified within fifteen days of delivery and the shipping container is retained for inspection.

The Blodgett Oven Company cannot assume responsibility for loss or damage suffered in transit. The carrier assumed full responsibility for delivery in good order when the shipment was accepted. We are, however, prepared to assist you if filing a claim is necessary.

OVEN LOCATION

The well planned and proper placement of your oven will result in long term operator convenience and satisfactory performance.

The following clearances must be maintained between the oven and any combustible or non-combustible construction.

- Oven body right side - 6" (15cm)
- Oven body left side - 6" (15cm)
- Oven body back - 6" (15cm)
- Single and stacked oven bottom - 6" (15cm)

Area must be accessible for proper servicing.

NOTE: On gas models, routine servicing can usually be accomplished within the limited movement provided by the gas hose restraint. If the oven needs to be moved further from the wall, the gas must first be turned off and disconnected from the oven before removing the restraint. Reconnect the restraint after the oven has been returned to its normal position.

It is essential that an adequate air supply to the oven be maintained to provide a sufficient flow of combustion and ventilation air.

- Place the oven in an area that is free of drafts.
- Keep the oven area free and clear of all combustibles such as paper, cardboard, and flammable liquids and solvents.
- Do not place the oven on a curb base or seal to a wall. Either condition will restrict the proper flow of combustion and ventilation air resulting in damage to the oven.



Oven Assembly

PACKAGING

Before beginning assembly of the oven, check for all necessary components. In addition to the oven itself, legs, a proper vent, and/or other accessories may be required.

900 Series ovens are packaged as follows:

Single Section Ovens

The following are packed in the oven:

- A set of 27-1/2" (70 cm) legs with attaching hardware.
- Either a canopy or direct vent as specified
- Either a natural gas or propane gas pressure regulator as required.

Multiple Section Ovens

The following are packed inside the bottom section:

- A set of legs of the appropriate length
- Either a canopy or direct vent as specified
- A back pipe of appropriate length with either a natural gas or propane gas regulator attached

Additional Packaging

- Ultra Rokite decks for all 900 Series are packed in a separate crate.
- The top section of multiple section ovens will always have the crown angle in position.

LEG ATTACHMENT

1. Put the oven onto a lift with the bottom of the oven down.
2. Each leg is attached by two bolts to the underside of the oven base frame.

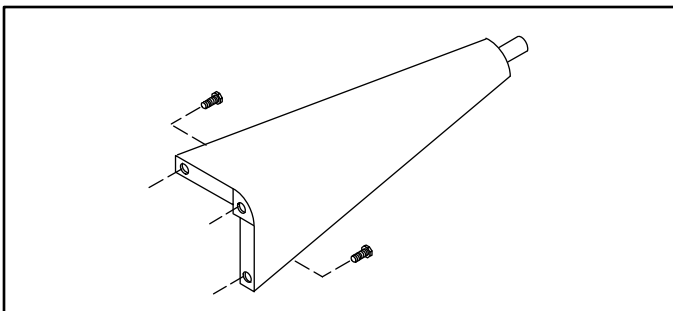

Figure 2

CASTER ATTACHMENT

1. Bolt supports to oven with 1/2-13 hex head bolts (casters with brakes should be facing front of oven.)
2. Carefully place oven onto the casters. (It will be necessary to have several persons lift oven off the pallet and set it onto the casters). Engage brakes on front casters.

NOTE: A fixed restraint must be provided if casters are used in conjunction with a flexible connector for movable appliances. This restraint must secure the oven to a non-movable surface to eliminate stress on the connector. If the oven is moved, the restraint must be re-connected after the oven is returned to its normal position.

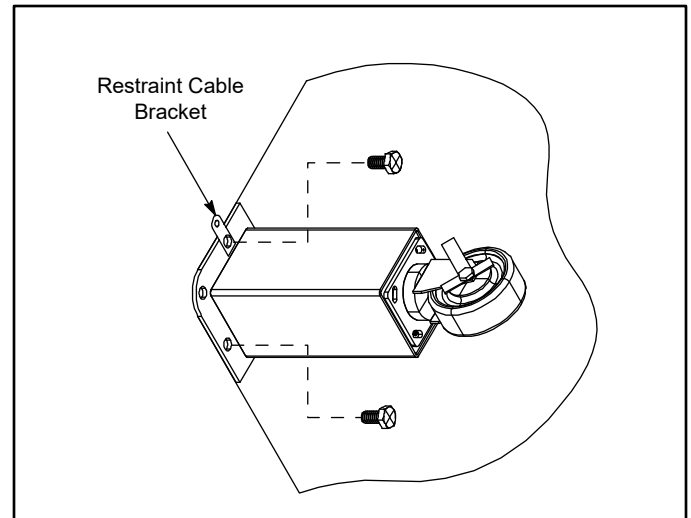

Figure 3



Installation

Oven Assembly

DOUBLE SECTION ASSEMBLY

1. Place lower section in predetermined place of installation.
2. Attach the legs (and casters if applicable) as previously described.
3. Using two 1" boards, place one near the edge of the oven and the other at the far side of the flue collar.
4. Lift the upper section and place on the boards. Push the top section across until the sections are even.
5. Remove the board from one side by placing a 2" x 4" approximately four feet long under the angle frame. Lift to remove the board.
6. Remove the other board in the same manner as above, allowing the upper section to come gently to rest in the proper position.
7. Install gas back-pipes and pressure regulator.
8. Install the canopy or direct type vent as appropriate.
9. Remove all tags.
10. Level the ovens side to side and front to back by placing a spirit level on the base frame of the lower section and screwing the adjustable leg feet in or out as appropriate.

ULTRA ROKITE DECK

1. Slide the Ultra Rokite shelf through the door opening. Rest the shelf on the deflector and slide to the rear of the oven until it drops into the shelf support.
2. Refer to pre-heating instructions supplied with Ultra Rokite.

NOTE: Because of the weight of the Ultra Rokite shelves, take care to avoid injury to yourself or damage to the shelves when sliding sections into the oven.

NOTE: For model 981, Ultra Rokite is only available as a bottom deck. DO NOT install the Ultra Rokite in the top baking compartment of a 981.

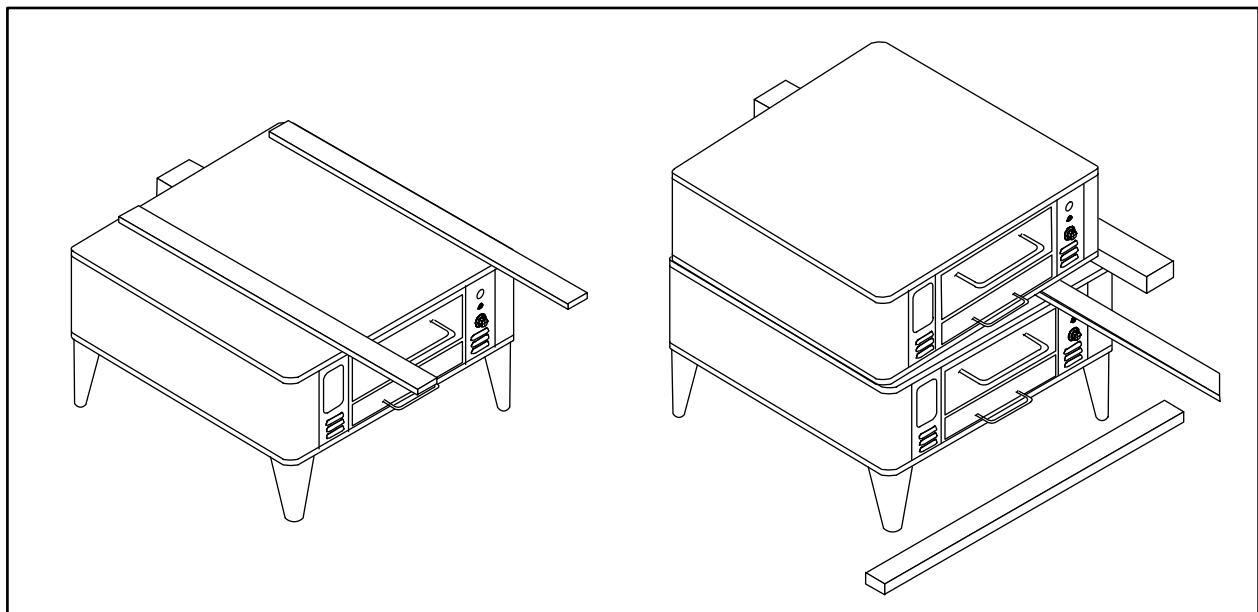

Figure 4

Oven Assembly

STEAM INJECTION

As an optional feature, all 900 Series ovens may be supplied with steam jets for baking hard rolls, and vienna, french or other hard crusted breads. This item is also available as a kit which may be installed in the field. To a baker, steam actually means an atmosphere of water vapor. Therefore, it is very important that the steam be low pressure (2-1/2 to 3 PSI), that condensate be taken from the steam line before it enters the oven, and that the steam be sufficiently saturated to give the vapor cloud effect required.

At least one quarter boiler horsepower for all large 900 Series compartment (42" x 32") or two small 900 Series compartments (33" x 22") is recommended. Several firms manufacture electric and gas fired steam generators ranging in size from 1/2 boiler horsepower upward. If the steam generator is mounted adjacent to the oven, line transmission losses will be insignificant. If the steam source is located a considerable distance from the oven, line transmission losses must be considered in determining the proper size of the steam. Please refer to the accompanying diagram for the recommended installation of the steam injection system.

WARNING!!

Gas Flame in oven must be turned off when steam is in use.

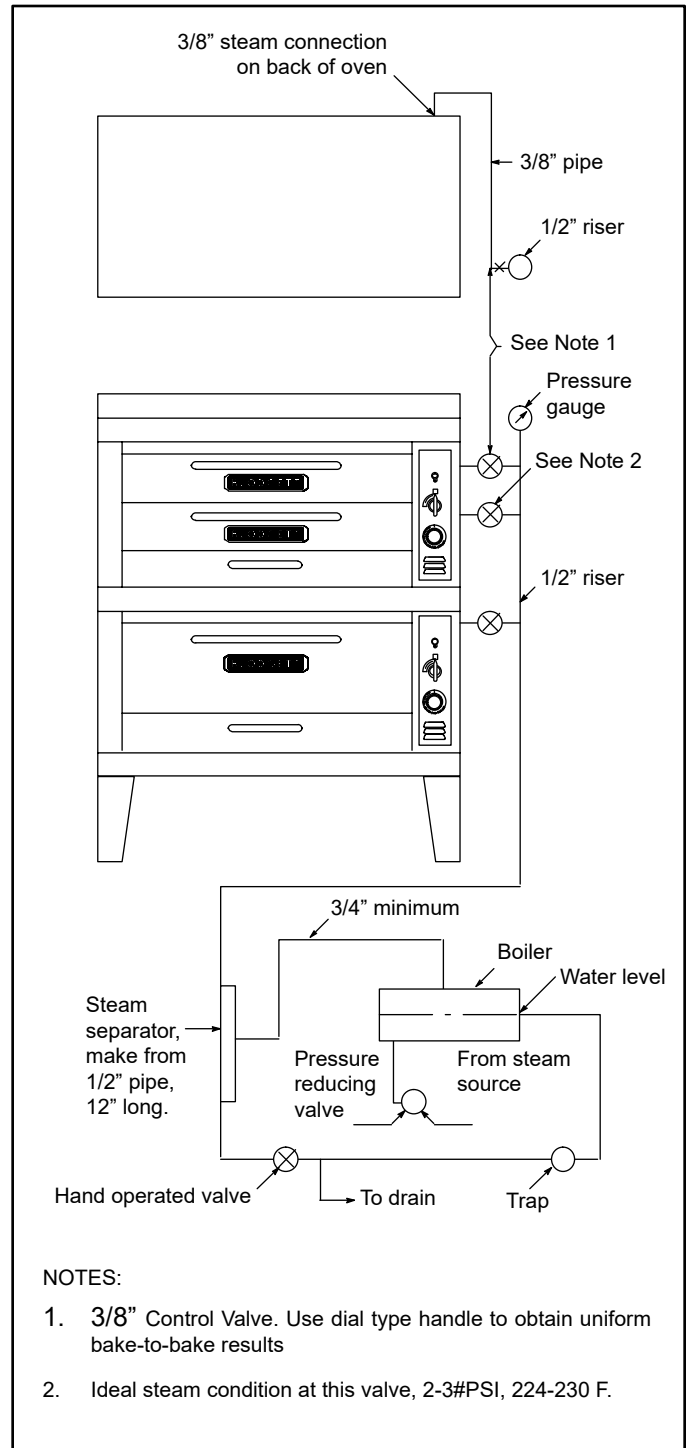

Figure 5



Installation

Ventilation

Blodgett gas deck ovens are direct fired. Heat and flue products from the burners are introduced directly into the baking compartment. As a result, improper venting can have a detrimental effect on the baking characteristics of the oven. A properly designed ventilation system will allow the oven to function properly, while removing unwanted vapors and products of combustion from the operating area.

This oven may be vented using either:

- A mechanically driven, canopy type, exhaust hood, or
- A direct flue arrangement.

U.S. and Canadian installations

Refer to your local ventilation codes. In the absence of local codes, refer to the National ventilation code titled, "Standard for the Installation of Equipment for the Removal of Smoke and Grease Laden Vapors from Commercial Cooking Equipment", NFPA-96-Latest Edition.

General export installations

Installation must conform with Local and National installation standards. Local installation codes and/or requirements may vary. If you have any questions regarding the proper installation and/or operation of your Blodgett oven, please contact your local distributor. If you do not have a local distributor, please call the Blodgett Oven Company at 0011-802-658-6600.

The Blodgett Oven Company cannot assume responsibility for loss or damage suffered as a result of improper installation..



WARNING:

Failure to properly vent the oven can be hazardous to the health of the operator and may result in operational problems, unsatisfactory baking and possible damage to the equipment.

Damage sustained as a direct result of improper ventilation will not be covered by the Manufacturer's warranty.

CANOPY TYPE EXHAUST HOOD

A mechanically driven, canopy type exhaust hood is the preferred method of ventilation.

The hood should be sized to completely cover the equipment plus an overhang of at least 6" (15 cm) on all sides not adjacent to a wall. The distance from the floor to the lower edge of the hood should not exceed 7' (2.1m).

The capacity of the hood should be sized appropriately with provisions for an adequate supply of make up air. Capacity is generally expressed in ft³/min (CFM). 1 CFM of natural gas burned with just enough air for complete combustion produces 11 CFM of combustion products. In virtually all appliances some excess air is used. This volume of excess air is added to the flue products flowing from the appliance.

NOTE: Consult your local exhaust hood contractor for your specific installation.

Installing the canopy hood draft diverter

Ovens ordered for hood venting are supplied with a draft diverter. Install the draft diverter as follows:

1. Place the diverter over the flue connector with the open area facing the front of the oven.
2. Secure both ends with the sheet metal screws provided.

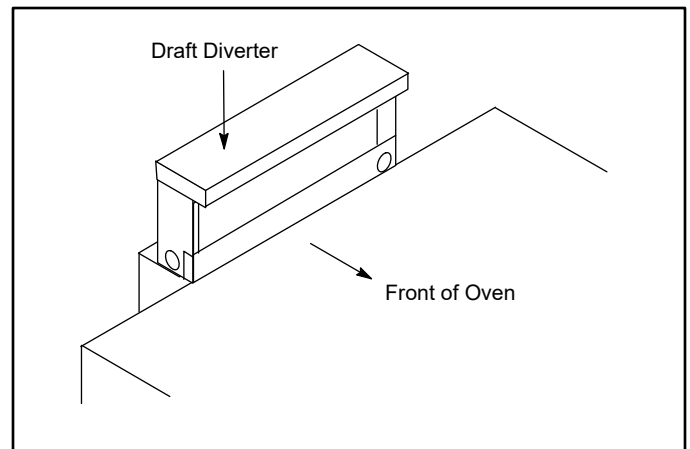

Figure 6

DIRECT FLUE ARRANGEMENT

When the installation of a mechanically driven exhaust hood is impractical the oven may be vented by a direct flue arrangement.

WARNING!!

It is essential that the direct flue be installed as follows. Incorrect installation will result in unsatisfactory baking and oven damage.

The flue must be class B or better with a diameter of 6" (15 cm). The height of the flue should rise 6-8 ft (2-2.5 m) above the roof of the building or any proximate structure. Never direct vent the oven into a hood. The flue should be capped with a UL Listed type vent cap to isolate the unit from external environmental conditions.

The direct vent cannot replace air consumed and vented by the oven. Provisions must be made to supply the room with sufficient make-up air. To increase the supply air entering the room, a ventilation expert should be consulted.

Installing the draft hood

Ovens ordered for direct venting are supplied with a draft hood. Install the draft hood as follows:

1. Place the draft hood over the flue connector.
2. Secure both ends with the sheet metal screws provided.

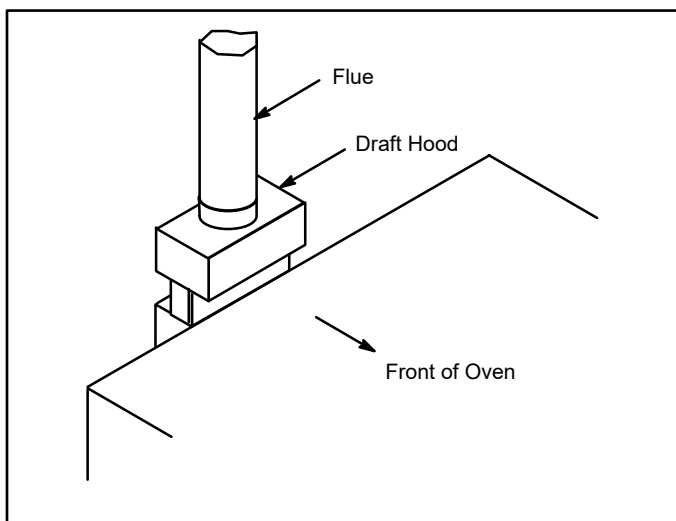

Figure 7

VENTING PROBLEMS

Blodgett gas deck ovens use the natural principal of heat rising as the basic method of ventilation. If the venting of any deck oven is either restricted or forced in any way the baking characteristics of the oven will be adversely affected.

Examples of forced venting include:

- installation of a fan in a direct vent pipe
- use of a canopy type hood without the draft diverter

Examples of restricted venting include:

- use of tees and elbows
- long horizontal runs



Installation

Utility Connections - Standards and Codes

THE INSTALLATION INSTRUCTIONS CONTAINED HEREIN ARE FOR THE USE OF QUALIFIED INSTALLATION AND SERVICE PERSONNEL ONLY. INSTALLATION OR SERVICE BY OTHER THAN QUALIFIED PERSONNEL MAY RESULT IN DAMAGE TO THE OVEN AND/OR INJURY TO THE OPERATOR.

Qualified installation personnel are individuals, a firm, a corporation, or a company which either in person or through a representative are engaged in, and responsible for:

- the installation or replacement of gas piping and the connection, installation, repair or servicing of equipment.
- the installation of electrical wiring from the electric meter, main control box or service outlet to the electric appliance.

Qualified installation personnel must be experienced in such work, familiar with all precautions required, and have complied with all requirements of state or local authorities having jurisdiction.

U.S. and Canadian installations

The installation must conform with local codes, or in the absence of local codes, with the National Fuel Gas Code, ANSI Z223.1/NFPA 54, or the Natural Gas and Propane Installation Code, CSA B149.1, as applicable.

Installation must conform with local codes, or in the absence of local codes, with the National Electrical Code, ANSI/NFPA 70-Latest Edition and/or Canadian National Electric Code C22.1 as applicable.

Appliance is to be installed with backflow prevention in accordance with applicable federal, province and local codes.

Australia and general export installations

Installation must conform with Local and National installation standards. Local installation codes and/or requirements may vary. If you have any questions regarding the proper installation and/or operation of your Blodgett oven, please contact your local distributor. If you do not have a local distributor, please call the Blodgett Oven Company at 0011-802-658-6600.



Gas Connection

GAS PIPING

A properly sized gas supply system is essential for maximum oven performance. Piping should be sized to provide a supply of gas sufficient to meet the maximum demand of all appliances on the line without loss of pressure at the equipment.

Example:

NOTE: BTU values in the following example are for natural gas.

You purchase a Model 911 deck oven to add to your existing cook line.

1. Add the BTU rating of your current appliances.

Pitco Fryer	120,000 BTU
6 Burner Range	60,000 BTU
Deck Oven	50,000 BTU
Total	230,000 BTU

2. Add the BTU rating of the new oven to the total.

Previous Total	230,000 BTU
911	20,000 BTU
New Total	250,000 BTU

3. Measure the distance from the gas meter to the cook line. This is the pipe length. Let's say the pipe length is 40' (12.2 m) and the pipe size is 1" (2.54 cm).

4. Use the appropriate table to determine the total capacity of your current gas piping.

The total capacity for this example is 320,000 BTU. Since the total required gas pressure, 250,000 BTU is less than 320,000 BTU, the current gas piping will not have to be increased.

NOTE: The BTU capacities given in the tables are for straight pipe lengths only. Any elbows or other fittings will decrease pipe capacities. Contact your local gas supplier if you have any questions.

Maximum Capacity of Iron Pipe in Cubic Feet of Natural Gas Per Hour

(Pressure drop of 0.5 Inch W.C.)

PIPE LENGTH (FT)	NOMINAL SIZE, INCHES				
	3/4"	1"	1-1/4"	1-1/2"	2"
10	360	680	1400	2100	3950
20	250	465	950	1460	2750
30	200	375	770	1180	2200
40	170	320	660	990	1900
50	151	285	580	900	1680
60	138	260	530	810	1520
70	125	240	490	750	1400
80	118	220	460	690	1300
90	110	205	430	650	1220
100	103	195	400	620	1150

From the National Fuel Gas Code Part 10 Table 10-2

Maximum Capacity of Pipe in Thousands of BTU/hr of Undiluted L.P. Gas at 11" W.C.

(Pressure drop of 0.5 Inch W.C.)

PIPE LENGTH (FT)	OUTSIDE DIAMETER, INCHES		
	3/4"	1"	1-1/2"
10	608	1146	3525
20	418	788	2423
30	336	632	1946
40	287	541	1665
50	255	480	1476
60	231	435	1337
70	215	404	1241
80	198	372	1144
90	187	351	1079
100	175	330	1014

From the National Fuel Gas Code Part 10 Table 10-15



Installation

Gas Connection

PRESSURE REGULATION AND TESTING

900 Series ovens are rated from 20,000 to 50,000 BTU/Hr. (6.4 to 14.6 kW/Hr.) per section. Each oven has been adjusted at the factory to operate with the type of gas specified on the rating plate.

1. Pull out control panel. The rating plate is attached to the inside of the control compartment.

INLET PRESSURE				
	Natural		Propane	
	Min	Max	Min	Max
W.C.	7.0	10.5	11.0	13.0
kPa	1.43	2.61	2.74	3.23
MANIFOLD PRESSURE				
	Natural		Propane	
W.C.	5.0		10.0	
kPa	1.24		2.49	

- Inlet Pressure - the pressure of the gas before it reaches the oven.
- Manifold Pressure - the pressure of the gas as it enters the main burner(s).
- Min - the minimum pressure recommended to operate the oven.
- Max - the maximum pressure at which the manufacturer warrants the oven's operation.

Each oven is supplied with a regulator to maintain the proper gas pressure. The regulator is essential to the proper operation of the oven and must be installed. It is preset to provide the oven with 3.5" W.C. (0.87 kPa) for natural gas and 10.5" W.C. (2.50 kPa) for Propane at the manifold.

DO NOT INSTALL AN ADDITIONAL REGULATOR WHERE THE OVEN CONNECTS TO THE GAS SUPPLY.

Prior to connecting the oven, gas lines should be thoroughly purged of all metal filings, shavings, pipe dope, and other debris. After connection, the oven should be checked for correct gas pressure.

Installation must conform with local codes, or in the absence of local codes, with the National Fuel Gas Code, NFPA54/ANSI Z223.1-Latest Edition, the Natural Gas Installation Code CAN/CGA-B149.1 or the Propane Installation Code, CAN/CGA-B149.2 as applicable.

The oven and its individual shutoff valve must be disconnected from the gas supply piping system during any pressure testing of that system at test pressures in excess of 1/2 psig (3.45kPa).

The oven must be isolated from the gas supply piping system by closing its individual manual shutoff valve during any pressure testing of the gas piping system at test pressures equal or less than 1/2 psig (3.45kPa).

GAS HOSE RESTRAINT

If the oven is mounted on casters, a commercial flexible connector with a minimum of 3/4" (1.9 cm) inside diameter must be used along with a quick connect device.

The restraint, supplied with the oven, must be used to limit the movement of the unit so that no strain is placed upon the flexible connector. With the restraint fully stretched the connector should be easy to install and quick connect.

The restraint (ie: heavy gauge cable) should be 1,000 lb. (453 kg) test load and should be attached without damaging the building. **DO NOT** use the gas piping or electrical conduit for the attachment of the permanent end of the restraint! Use anchor bolts in concrete or cement block. On wooden walls, drive hi test wood lag screws into the studs of the wall.

1. Mount the supplied bracket to the leg bolt just below the gas inlet.
2. The clip on restraining cable can be attached to the mounting bracket.

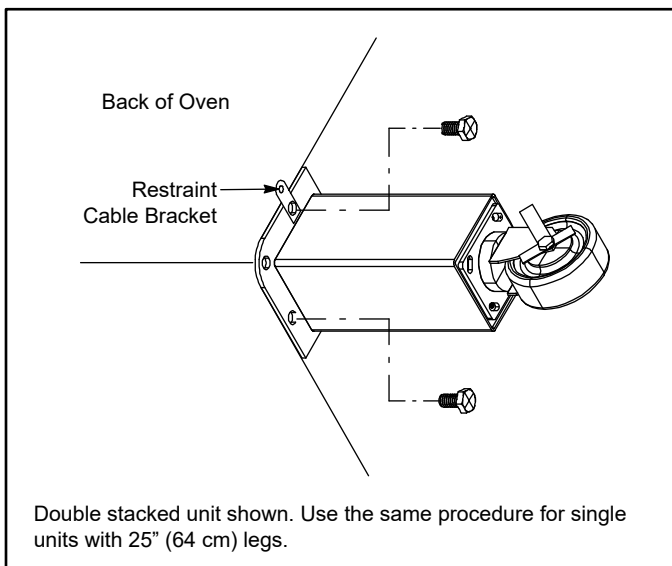

Figure 8

WARNING!!

If the restraint is disconnected for any reason it must be reconnected when the oven is returned to its original position.

U.S. and Canadian installations

The connector must comply with the Standard for Connectors for Movable Gas Appliances, ANSI Z21.69 or Connectors For Moveable Gas Appliances CAN/CGA-6.16 and a quick disconnect device that complies with the Standard for Quick-Disconnect Devices for Use With Gas Fuel, ANSI Z21.41 or Quick Disconnect For Use With Gas Fuel CAN 1-6.9. Adequate means must be provided to limit the movement of the appliance without depending on the connection and the quick disconnect device or its associated piping. Adequate means must be provided to limit the movement of the appliance without depending on the connection and the quick disconnect device or its associated piping.

General export installations

The restraint and quick connect must conform with Local and National installation standards. Local installation codes and/or requirements may vary. If you have any questions regarding the proper installation and/or operation of your Blodgett oven, please contact your local distributor. If you do not have a local distributor, please call the Blodgett Oven Company at 0011-802-658-6600.



Installation

Initial Startup

ADJUSTMENTS ASSOCIATED WITH INITIAL INSTALLATION

Each oven, and its component parts, have been thoroughly tested and inspected prior to shipment. However, it is often necessary to further test or adjust the oven as part of a normal and proper installation. These adjustments are the responsibility of the installer, or dealer. Since these adjustments are not considered defects in material or workmanship, they are not covered by the Original Equipment Warranty. They include, but are not limited to:

- calibration of the thermostat
- adjustment of the doors
- burner adjustments
- leveling
- testing of gas pressure
- tightening of fasteners

No installation should be considered complete without proper inspection, and if necessary, adjustment by qualified installation or service personnel.

The information contained in this section is provided for the use of qualified operating personnel. Qualified operating personnel are those who have carefully read the information contained in this manual, are familiar with the functions of the oven and/or have had previous experience with the operation of the equipment described. Adherence to the procedures recommended herein will assure the achievement of optimum performance and long, trouble-free service.

Please take the time to read the following safety and operating instructions. They are the key to the successful operation of your Blodgett oven.

SAFETY TIPS

For your safety read before operating

What to do if you smell gas:

- DO NOT try to light any appliance.
- DO NOT touch any electrical switches.
- Use an exterior phone to call your gas supplier immediately.
- If you cannot reach your gas supplier, call the fire department.

General safety tips:

- DO NOT use tools to turn off the gas control. If the gas cannot be turned off manually do not try to repair it. Call a qualified service technician.
- If the oven needs to be moved for any reason, the gas must be turned off and disconnected from the unit before removing the restraint cable. Reconnect the restraint after the oven has been returned to its original location.

Please take the time to read the following operating instructions. They are the key to the successful operation of your Blodgett deck oven.

WARNING!!

In the event of a loss of pilot, allow a five (5) minute shut off period before attempting to relight the oven.



Operation

Oven Control

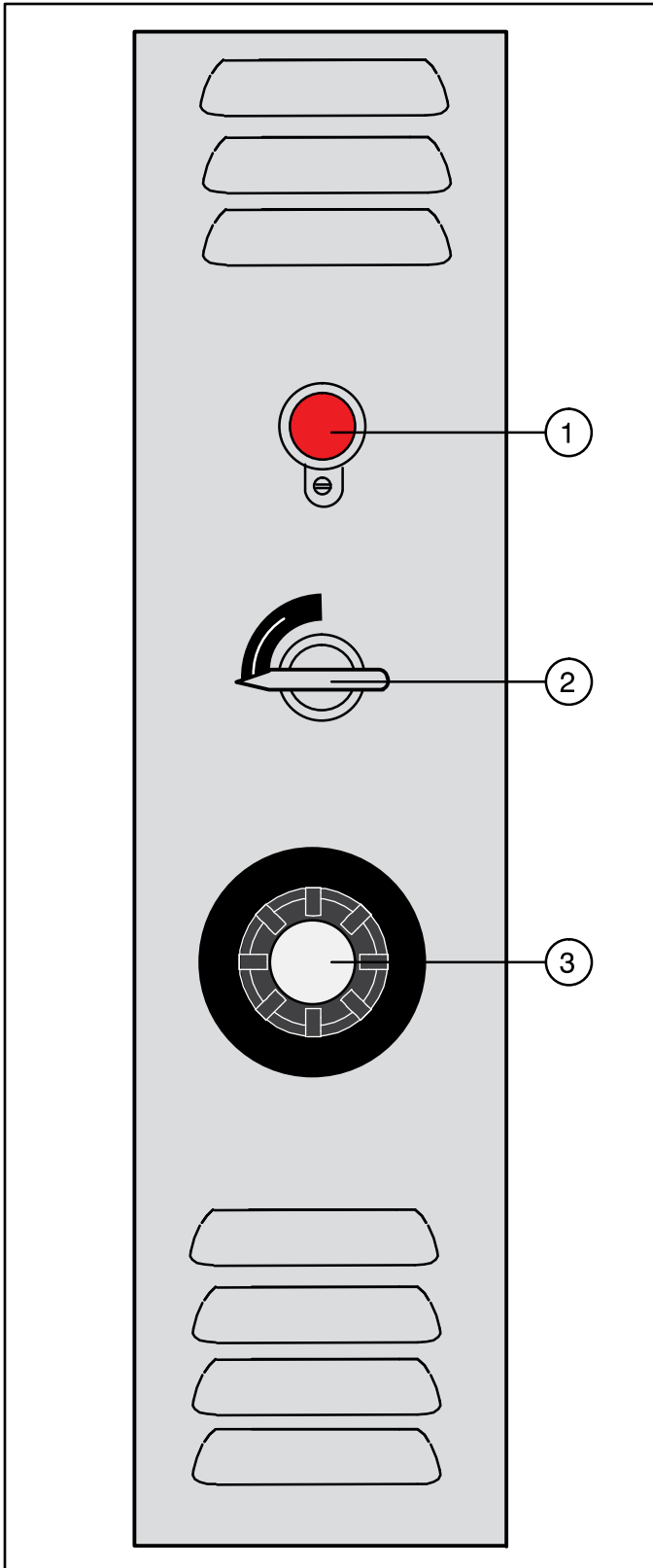

Figure 9

CONTROL DESCRIPTION

1. AUTOMATIC SAFETY PILOT VALVE - provides complete gas shut-off in the event of pilot failure.
2. MANUAL CONTROL VALVE - provides manual control of gas flow to the main burner through the thermostat.
3. THERMOSTAT - Provides regulation of oven temperature at setting selected by the oven operator.

OPERATION

Lighting

1. Turn the manual control valve (2) to OFF.
2. Push the red button on the automatic safety pilot valve (1).
3. Apply a lighted match or taper to pilot burner.
4. After pilot burner lights, continue to depress red button for about 30 seconds and release.
5. Turn the manual control valve (2) to ON.
6. Set THERMOSTAT (3) to desired temperature.

Preheating

1. On initial startup, preheat the oven to 500°F (260°C) two hours prior to loading and check oven periodically. This will allow paint to set properly.

Loading

- The deck is intended for cooking pizza and bread products, other types of food may be cooked in pans or containers.
- Load each baking shelf evenly.
- Do not allow pans to touch each other or sides of oven.
- Do not load additional products after goods have begun to bake.
- Open doors as seldom as possible.
- In two shelf ovens, load lower compartment first.

To turn the oven off

1. Turn the manual control valve (2)

Suggested Times and Temperatures

PRODUCT	TEMPERATURE	COOK TIME
Meats		
Beef		
Ribs	325°F (165°C)	rare - 16 mins/lb med - 20 mins/lb well - 25 mins/lb
Rolled, boneless	325°F (165°C)	add 10 mins/lb to above times
Hip or rump, boneless	325°F (165°C)	30 mins/lb
Veal		
Bone-in cuts	325°F (165°C)	25 mins/lb
Boned cuts	325°F (165°C)	30 mins/lb
Lamb		
Leg or shoulder	325°F (165°C)	35 mins/lb
Shoulder, boned	325°F (165°C)	40 mins/lb
Pork		
Fresh bone-in cuts	350°F (175°C)	30-40 mins/lb
Fresh boned cuts	350°F (175°C)	40-50 mins/lb
Hams	325°F (165°C)	25-30 mins/lb
Bacon	350°F (175°C)	depends on degree of doneness
Sausages, links, patties	350°F (175°C)	30 mins/lb
Meat pies, deep dish	450°F (230°C)	12-15 mins/lb
Poultry (<i>Weights are for unstuffed birds, for stuffed, add 15 mins/lb</i>)		
Chickens, 2-3 lbs	350°F (175°C)	35 mins/lb
Chickens, over 5 lbs	325°F (165°C)	20-25 mins/lb
Chicken pies	450°F (230°C)	15-25 mins/lb
Turkeys, 10-16 lbs	325°F (165°C)	18-20 mins/lb
Turkeys, 25 lbs	325°F (165°C)	15-18 mins/lb
Ducks	Same as chickens	Same as chickens
Geese	Same as turkeys	Same as turkeys
Fish		
Fish, whole	350°F (175°C)	15 mins/lb
Fish fillets	350°F (175°C)	15-20 mins/lb
Lobster	400°F (200°C)	Approximately 20 mins/lb
Oysters, casino	350°F (175°C)	15 mins
Oysters, devilled	350°F (175°C)	15 mins
Oysters, Rockefeller	450°F (230°C)	10 mins
<i>NOTE: Actual times and temperatures may vary considerably from those shown above. They are affected by weight of load, temperature of the product, recipe, type of pan and calibration of thermostat. Should your recipe vary, write in your proven time and temperature for ready reference.</i>		



Operation

Suggested Times and Temperatures

PRODUCT	TEMPERATURE	COOK TIME
Baked Vegetables		
Bananas	350°F (175°C)	15-20 mins/lb
Boston Beans	250°F (120°C)	8 hrs
Carrots	400°F (200°C)	Until tender
Egg plant	350°F (175°C)	Until tender
Macaroni	350°F (175°C)	15-25 mins/lb
Stuffed peppers	350°F (175°C)	25 mins/lb
Potatoes	400°F (200°C)	45 - 1 1/2 hrs
Tomatoes	350°F (175°C)	15-20 mins/lb
Cheese		
Cheese fondue	350°F (175°C)	40 mins/lb
Cheese loaf	325°F (165°C)	40 mins/lb
Toasted cheese	350°F (175°C)	15 mins/lb
Cheese souffle	300°F (150°C)	20 mins/lb
Au gratin dishes	450°F (230°C)	Until browned
Breads		
Bread, white, yeast	375-425°F (230°C)	30-45 mins
Raisin	400°F (200°C)	40 mins
Breads, rye	375°F (190°C)	49-90 mins
Rolls, standard white	375-400°F (200°C)	20-45 mins
Rolls, Parker House	400-425°F (200°C)	15-20 mins
Biscuits	375-400°F (220°C)	15-25 mins
Danish pastry	375-400°F (200°C)	20-35 mins
Desserts		
Fresh fruit pie	375-400°F (200°C)	50-60 mins
Pies, precooked filling	475°F (245°C)	20-35 mins
Pie shells	400-450°F (230°C)	15 mins
Pies, custard	325-450°F (230°C)	Depending upon mix
Cookies	400-475°F (245°C)	8-15 mins
Cheesecake, standard	350°F (175°C)	40 mins
Devil's food	360-375°F (190°C)	20-25 mins
White layer cake	350-375°F (190°C)	20-35 mins
Baked apples	400°F (200°C)	Approximately 1 hr
Fruit pudding	375°F (190°C)	1 hr
Indian pudding	325°F (165°C)	3 hrs
Rice pudding	350°F (175°C)	variable

NOTE: Actual times and temperatures may vary considerably from those shown above. They are affected by weight of load, temperature of the product, recipe, type of pan and calibration of thermostat. Should your recipe vary, write in your proven time and temperature for ready reference.



Cleaning and Preventative Maintenance

CLEANING THE OVEN

Painted and stainless steel ovens may be kept clean and in good condition with a light oil.

1. Saturate a cloth, and wipe the oven when it is cold.
2. Dry the oven with a clean cloth.

On the stainless front or interiors, deposits of baked on splatter may be removed with any non-toxic industrial stainless steel cleaner. Heat tint and heavy discoloration may be removed with any non-toxic commercial oven cleaner.

1. Apply cleaners when the oven is cold, and always rub with the grain of the metal.

Clean Ultra Rokite decks with a triangular scraper used for cleaning broiler grids. **IMPORTANT - DO NOT use water or any other liquids to clean the deck!**

Clean the aluminized interior portion of the oven with a mild detergent. DO NOT use caustic solutions such as ammonia, lye or soda ash. DO NOT use domestic oven cleaners. Any of these products will damage the aluminum coating.

Daily Cleaning

- Remove residue from beneath the doors with a small broom or brush.

Weekly Cleaning

- Brush out the combustion compartment and control area.
- In addition to the daily cleaning it is necessary to clean the air intakes on a weekly basis. Air intakes provide necessary cooling air to the internal components. They are generally located on the rear and sides of the equipment.

6 Month Cleaning

- Clean secondary air ducts and air entry ports.

NOTE: If the oven is moved the restraint must be reconnected after the unit is returned to its regular position.

PREVENTATIVE MAINTENANCE

The best preventative maintenance measures are, the proper installation of the equipment and a program for routinely cleaning the ovens.

This oven requires no lubrication, however, the venting system should be checked annually for possible deterioration resulting from moisture and corrosive flue products.

If maintenance or repairs are required, contact the factory, the factory representative or a local Blodgett service company.



Maintenance

Troubleshooting Guide

POSSIBLE CAUSE(S)	SUGGESTED REMEDY
SYMPTOM: Strong bottoms on the bakes	
<ul style="list-style-type: none"> • Too much bottom heat • High gas pressure • Faulty flue (strong direct vent) • Product left in the oven too long 	<ul style="list-style-type: none"> • Reduce cook temperature and increase time • * • * • Shorten cook time
SYMPTOM: Uneven bakes	
<ul style="list-style-type: none"> • Poor ventilation • Oven doors left open too long • Improper scaling of dough • Fluctuating gas pressure • Warped pans 	<ul style="list-style-type: none"> • * • Do not open door unnecessarily • Scale dough consistently • * • Change pans
SYMPTOM: Product burning	
<ul style="list-style-type: none"> • Thermostat set too high • Product left in the oven too long • By-pass flame too high • High gas pressure • Thermostat out of calibration • Heat deflectors worn out 	<ul style="list-style-type: none"> • Reduce cook temperature • Shorten cook time • * • * • * • *
SYMPTOM: Product dried out	
<ul style="list-style-type: none"> • Oven temperature too low • Not using enough water in the mix • Thermostat out of calibration • Faulty flue (strong direct vent) 	<ul style="list-style-type: none"> • Increase cook temperature • Increase water in product mix • * • *
SYMPTOM: Extended baking times	
<ul style="list-style-type: none"> • Temperature setting too low • Low gas pressure • Strong ventilation • Excessive door openings 	<ul style="list-style-type: none"> • Increase cook time • * • * • Do not open door unnecessarily

**Denotes remedy is a difficult operation and should be performed by qualified personnel only. It is recommended, however, that All repairs and/or adjustments be done by your local Blodgett service agency and not by the owner/operator. Blodgett cannot assume responsibility for damage as a result of servicing done by unqualified personnel.*