



**BAKERS  
PRIDE®**



OPERATION MANUAL

**IL FORNO & SUPERDECK SERIES GAS DECK OVENS**

**SERIES: FC**



**BUILT BY CRAFTSMEN. TESTED BY TIME.®**



## IL FORNO CLASSICO OVEN OPERATION MANUAL

### IL FORNO CLASSICO OVENS

**Series:**

**FC-516, FC-616 and FC-816**

All gas operated Bakers Pride® deck ovens are intended for use with the type of gas specified on the rating plate and for installation will be in accordance with National Fuel Gas Code ANSI Z223.1 (latest edition).

Please retain this manual for future references.

#### **⚠ WARNING**

**FOR YOUR SAFETY:** Do not store or use gasoline or other flammable vapors or liquids in the vicinity of this or any other appliance.

#### **⚠ WARNING**

**IMPORTANT INSTRUCTIONS:** After the gas supply has been connected to your unit, it is extremely important to check piping for possible leaks. To do this, use soap and water solution or solutions that are expressly made for this purpose.

**DO NOT USE** matches, candles, flames, or other sources of ignition since these methods are extremely dangerous. Post in a prominent location instructions to be followed in the event you smell gas. Obtain these instructions from your local gas supplier.

#### **NOTICE**

Only Pizza or Bread can have direct contact with Fibrament decks. All other food products must be placed in a pan or container to avoid direct contact with ceramic decks.

#### **⚠ CAUTION**

Improper installation, adjustment, alteration, service or maintenance can cause property damage, injury or death. Read the installation, operating and maintenance instructions thoroughly before installing or servicing this equipment.

#### **NOTICE**

Instructions to be followed in the event the user smells gas must be posted in a prominent location in the kitchen area. This information shall be obtained from the local gas supplier.

#### **⚠ WARNING**

California Residents Only

**WARNING:** This product can expose you to chemicals including chromium which is known to the State of California to cause cancer and birth defects or other reproductive harm. For more information go to [www.P65Warnings.ca.gov](http://www.P65Warnings.ca.gov).

This equipment is design engineered for commercial use only.

**BAKERS PRIDE OVEN COMPANY, LLC.**

265 Hobson St. • Smithville, TN 37166

Phone: 800.527.2100 | [www.bakerspride.com](http://www.bakerspride.com)



## IL FORNO CLASSICO OVEN OPERATION MANUAL

### TABLE OF CONTENTS

|  |          |  |           |
|--|----------|--|-----------|
| <b>INSTALLATION INSTRUCTIONS</b>         | <b>2</b> | <b>OPERATING INSTRUCTIONS</b>          | <b>10</b> |
| <b>RECEIVING</b>                         | <b>2</b> | <b>LIGHTING PROCEDURES</b>             | <b>10</b> |
| <b>CLEARANCES</b>                        | <b>2</b> | <b>BREAKING-IN</b>                     | <b>10</b> |
| <b>SET-UP</b>                            | <b>3</b> | <b>BAKING</b>                          | <b>10</b> |
| <b>MOUNTING LEGS WITH CASTERS</b>        | <b>4</b> | <b>RECOMMENDED OPERATING PROCEDURE</b> | <b>10</b> |
| <b>PIZZA DECKS</b>                       | <b>4</b> | <b>HELPFUL HINTS</b>                   | <b>11</b> |
| <b>THREE DECK INSTALLATION</b>           | <b>5</b> | <b>CLEANING AND MAINTENANCE</b>        | <b>11</b> |
| <b>FOUR DECK INSTALLATION</b>            | <b>5</b> | <b>STAINLESS STEEL SURFACES</b>        | <b>11</b> |
| <b>OPTIONAL CERAMIC TOP INSTALLATION</b> | <b>5</b> | <b>PAINTED SURFACES</b>                | <b>12</b> |
| <b>BOOSTER BURNER INSTALLATION</b>       | <b>7</b> | <b>DOOR MECHANISM</b>                  | <b>12</b> |
| <b>GAS AND ELECTRIC CONNECTIONS</b>      | <b>7</b> | <b>FLUE VENT</b>                       | <b>12</b> |
| <b>SAFETY PILOT OPERATION</b>            | <b>8</b> | <b>OVEN INTERIOR</b>                   | <b>12</b> |
| <b>PILOT BURNER LIGHTING PROCEDURE</b>   | <b>8</b> | <b>BAKING CHAMBER</b>                  | <b>12</b> |
| <b>PILOT BURNER FLAME ADJUSTMENT</b>     | <b>8</b> | <b>BAKE DECKS</b>                      | <b>12</b> |
| <b>BURNER OPERATION</b>                  | <b>9</b> | <b>BURNER COMPARTMENT</b>              | <b>12</b> |
| <b>MAIN BURNER</b>                       | <b>9</b> | <b>TROUBLESHOOTING CHART</b>           | <b>13</b> |
| <b>BOOSTER BURNER</b>                    | <b>9</b> | <b>WIRING DIAGRAM</b>                  | <b>14</b> |
| <b>AERATION &amp; BY-PASS FLAME ADJ.</b> | <b>9</b> | <b>WARRANTY</b>                        | <b>15</b> |
| <b>THERMOSTAT CALIBRATION</b>            | <b>9</b> |  |           |
| <b>FLAME DIVERTERS</b>                   | <b>9</b> |  |           |

| EN 437<br>Gas Cat. | Gas and Supply<br>Pressures | Designated European Market = ◆ |        |        |        |        |        |        |        |        |        |        |        |        |        |        |  |
|--------------------|-----------------------------|--------------------------------|--------|--------|--------|--------|--------|--------|--------|--------|--------|--------|--------|--------|--------|--------|--|
|                    |                             | A<br>T                         | B<br>E | D<br>K | F<br>I | F<br>R | G<br>R | D<br>E | I<br>E | I<br>T | L<br>U | N<br>L | P<br>T | E<br>S | S<br>E | G<br>B |  |
| I2H                | G20 @ 20mbar                | ◆                              |        | ◆      | ◆      |        |        |        | ◆      | ◆      |        |        | ◆      | ◆      | ◆      | ◆      |  |
| I2L                | G25 @ 25mbar                |                                |        |        |        |        |        |        |        |        |        | ◆      |        |        |        |        |  |
| I2E                | G20 @ 20mbar                |                                |        |        |        |        |        | ◆      |        |        | ◆      |        |        |        |        |        |  |
| I2E+               | G20/25 @<br>20/25mbar       |                                | ◆      |        |        | ◆      |        |        |        |        |        |        |        |        |        |        |  |

For North America: 120 or 208/240 Volts, 1 Phaze, 60 Hz.

| TYPE OF GAS | MANIFOLD PRESSURE |
|-------------|-------------------|
| Natural     | 3.5" Water Column |
| LP          | 10" Water Column  |

| Models Covered: |         |    |       |        |    |
|-----------------|---------|----|-------|--------|----|
| MODEL           | BTU/HR  | KW | MODEL | BTU/HR | KW |
| FC-516          | 140,000 | 41 |       |        |    |
| FC-616          | 140,000 | 41 |       |        |    |
| FC-816          | 140,000 | 41 |       |        |    |

## INSTALLATION INSTRUCTIONS

### Receiving:

Read the notice on the outside carton regarding damage in transit. Damage discovered after opening the crate(s) / carton(s) is "CONCEALED DAMAGE" and the carrier must be notified immediately to send an inspector and also furnish the forms for the consignee's claim against the carrier.

When oven arrives, it should consist of: A crate or carton containing your new oven, a carton containing 4 legs with mounting hardware, and a strapped skid containing baking decks.

### ⚠ WARNING

In MASSACHUSETTS: All gas products must be installed by a "Massachusetts" licensed plumber or gas fitter. Ventilation hoods must be installed in accordance with NFPA-96, current edition, with interlocks as described in that standard.

### ⚠ WARNING

Installation must conform with local codes and/or with the latest edition of the ANS Z-223.1 National Fuel Gas Code in USA (CAN/CGA-B 149.1 or 2 Installation Code in Canada).

### ⚠ WARNING

This appliance must be installed by a competent person in accordance with the rules in force. In the U.K. Corgi registered installers (including the regions of British Gas) undertake to work to safe and satisfactory standards. This appliance must be installed in accordance with the current Gas Safety (Installation and Use) Regulations and the relevant Building Regulations/IEE Regulations. Detailed recommendations are contained in the British Standard Codes Of Practice BS 6172, BS 5440:Part 2 and BS 6891.

### Clearances:

|                                    | Combustible Construction | Non-Combustible Construction |
|------------------------------------|--------------------------|------------------------------|
| Minimum Clearance from: Left Side  | 3" (75mm)                | 0"                           |
| Minimum Clearance from: Right Side | 1" (25mm)                | 0"                           |
| Minimum Clearance from: Rear       | 3" (75mm)                | 2" (51mm)                    |

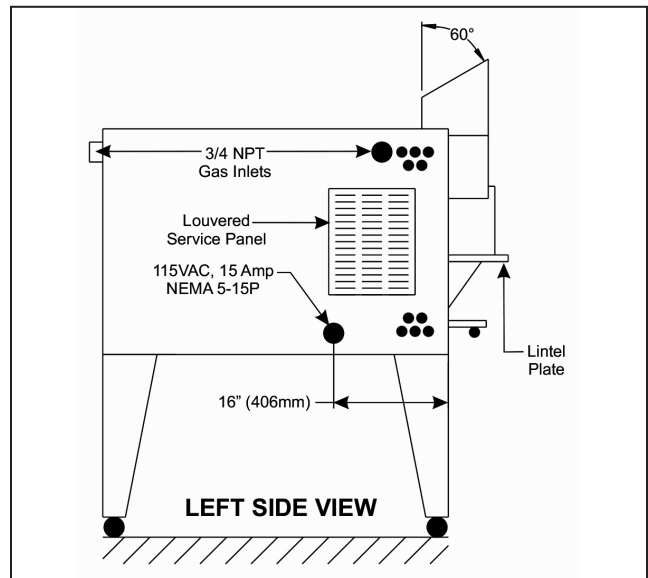

Sketch A

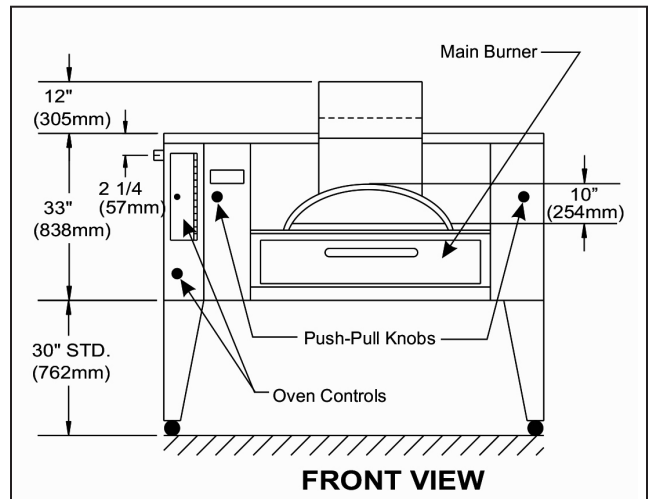

Sketch B

## INSTALLATION INSTRUCTIONS

- A. Provisions must be made for easy access to the louvered service panel on the left side of the unit. A removable panel at least 16" x 31" (406 x 787 mm) in line with the service panel to facilitate a service man to work will be satisfactory. See installation sketch "A".
- B. Reference to back panels deleted. No longer necessary.
- C. Easy accessibility through the front of the oven to the main burner, oven controls and flue slide push/pull knobs must be provided. See installation sketch "B".

Front and Flue Area - Enclose only with non-combustible materials.

### Set Up:

The oven must be installed in a well-ventilated area.

Your oven is packed standing on its back. Leave in on it's back while unpacking. The skid may be left under the oven for convenience in further handling. Unpack carefully to avoid damage to the oven. If concealed damage is found, follow the instructions detailed in Receiving Section.

Keep the area around the oven free and clear of combustible materials. Do not store any materials on top of or under any oven. Provisions for adequate air supply to your oven for ventilation and proper gas combustion is essential. As a minimum, observe the clearances detailed in Clearances Section.

Provide adequate ventilation and make up air in accordance with local codes.

The oven must be installed under a ventilation hood. Fit the flue diverter (see Sketch "C") into the hole in the top front of the oven and secure with the screws supplied. Local inspectors and ventilation specialists should be consulted to make sure that the installation of the hood conforms to the local codes and requirements (see Sketch "D").

In the U.K., ventilation requirements detailed in BS 5440 should be followed.

Access to the bottom front door and left side control panel is required for day to day operation of the oven and for servicing. Make sure that these areas are kept unobstructed for easy access.

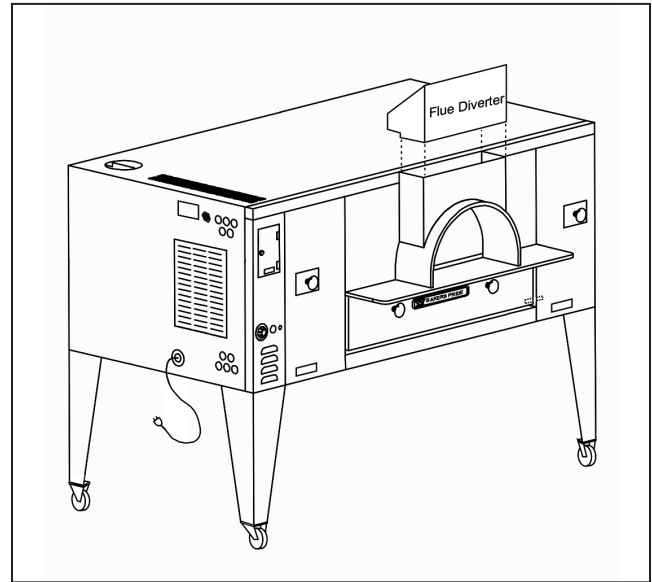

Sketch C

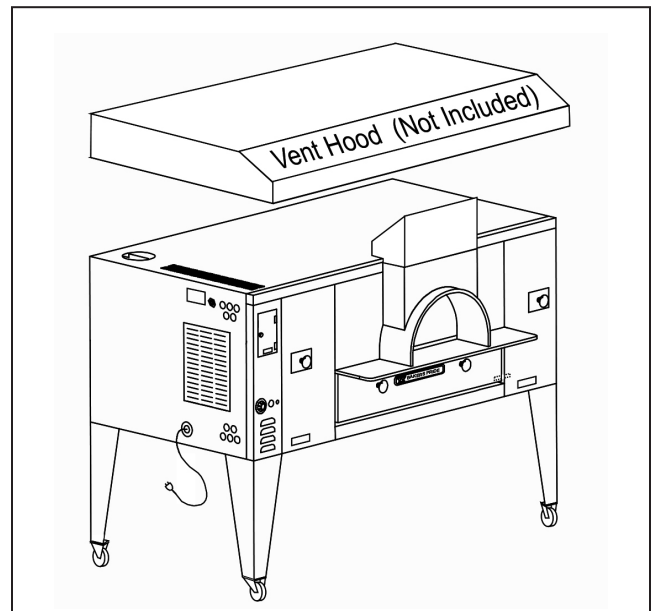

Sketch D

## INSTALLATION INSTRUCTIONS

### Mounting Legs With Casters:

Legs are shipped in a separate carton complete with mounting hardware and casters, (two of them with wheel brakes).

#### NOTICE

Installation should be made with a connector that complies with the latest edition of the Standard for Connectors for Movable Gas Appliances ANSI Z21.69 in the USA (CAN CGA-6.16 in Canada) and a quick disconnect device that complies with the latest edition of the Standard for Quick Disconnect Devices for use with gas fuel ANSI Z21.41 in the USA (CAN CGA 1-6.9 in Canada) and adequate means must be provided to limit the movement of the appliance without depending on the connector and any quick disconnect device or its associated piping.

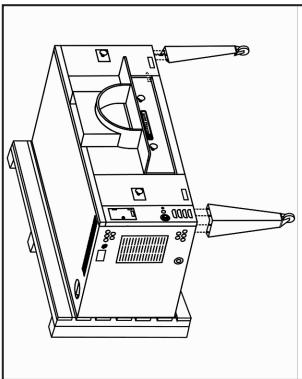

Sketch E

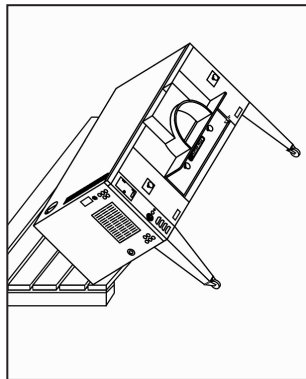

Sketch F

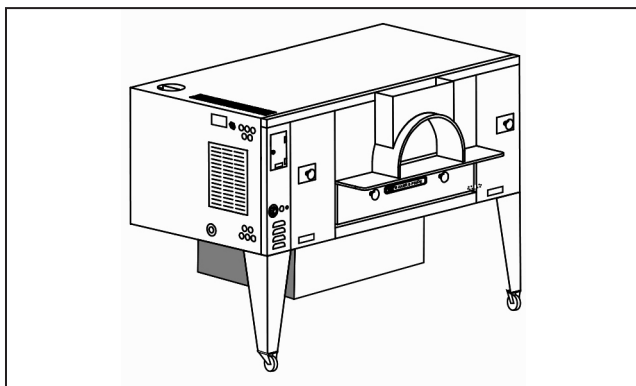

Sketch G

The restraint should be attached to the rear legs of the oven on which casters are mounted. If disconnection of the restraint is necessary to move the oven for servicing needs, the restraint should be reconnected after the appliance has been returned to its originally installed position.

- a) Bolt two (2) legs with casters and wheel brakes firmly to the two (2) upper (front) corners of the oven as it stands on the skid (see Sketch "E").
- b) Using proper lifting equipment, lower the oven down so that the two bolted legs rest on the floor (see Sketch "F").
- c) Using proper lifting equipment, raise the back side of the oven to a height slightly higher than the height of the legs, remove the skid and place a sturdy support under the back side (see Sketch "G"). Mount remaining two (2) legs and tighten bolts. Lift the oven and remove the supports.
- d) Move the oven to its final location, keeping the minimum clearances from the back of the oven to the wall. This clearance is necessary for safe operation and to provide proper air flow to the burner chamber.

### Pizza Deck:

- (a) Remove all packing material, samples, shims, etc. from the baking chamber leaving the two metal hearth liner sheets on the baking chamber floor. Make sure that the two metal hearth liner sheets cover the entire bottom of the chamber.
- (b) Three (model FC-616) and four (models FC-516 and FC-816) slabs of the Pizza Deck are provided with the oven. This material is heavy and fragile and should be handled carefully.

#### A. Three Deck Installation:

#### NOTICE

When sliding in the slabs, be very careful not to hit the booster burner components at the rear of the bake chamber.

#### NOTICE

If the side wedges are pushed in too tight, the heat controls, operated by the black knobs, located on the front of the oven, will not slide freely.

## INSTALLATION INSTRUCTIONS

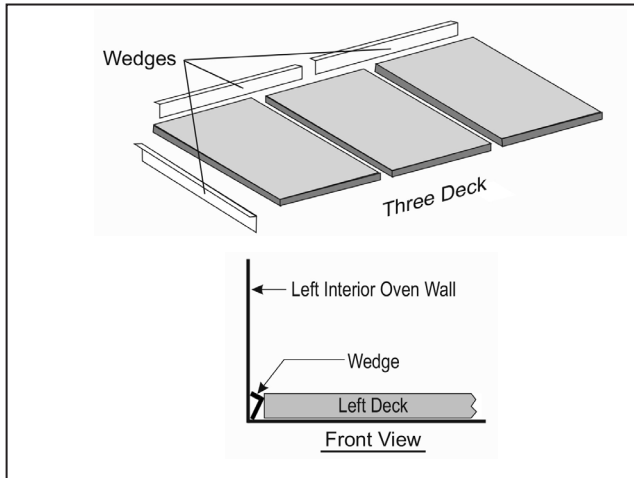

Sketch H

- Slide one slab into the bake chamber and push it as far as possible to one side.
- Slide the second slab into the bake chamber on the side opposite to the first slab.
- Slide the third slab into the center section.
- Use metal shims as needed to level the slabs.
- Use two wedges in the back and another on one side of the decks. The three slabs should be tight against each other with no gap in between them (See Sketch "H").

### B. Four Deck Installation:

- Slide the second slab into the bake chamber and push it next to the first slab in the rear.
- Slide the third and fourth slabs in front of the slabs already in place.
- Use metal shims as needed to level the slabs.
- Use one (FC-516) or two (FC-816) wedges in the back and another on one side of the decks. The four slabs should be tight against each other with no gap in between them (See Sketch "I").

### C. Optional Ceramic Top Installation

(Refer to Top Brick Lining Illustration, Page 6):

If the oven was ordered with the ceramic top option, the two top supports are already installed. Simply slide in the ceramic tops as per instructions below. If this option is an add-on, you must follow the instructions provided

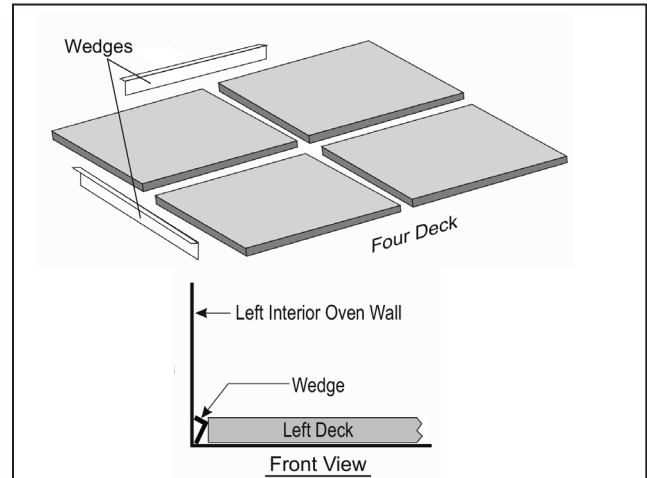

Sketch I

with the Ceramic Top Installation kit.

- Through the arched front opening, insert one of the center slabs (20 13/16 x 20 13/16 for FC616 and FC816)(17 1/2 x 17 3/4 (left to right) for the FC516) into the bake chamber, raise one side until the other side comes to rest onto the center support, then lower the first side to lock it in between the two center supports. Push it to the rear as far as possible to make room for the second center slab.
- Install the second center slab (20 13/16 x 20 13/16 for FC816)(14 3/16 x 20 13/16 (left to right) for FC616)(17 1/2 x 17 3/4 (left to right) for FC516) into the bake chamber and push it tightly against the first slab.
- Install the side slabs (20 13/16 x 20 13/16 for FC816)(17 1/2 x 17 3/4 (left to right) for FC616) (17 1/2 x 13 3/4 (left to right) for FC516) in a similar fashion, raising the slab in the center until the lower side edge rests on the side support, then lowering the upper edge onto the center support. First the ones in the rear, then the ones in the front, pushing them tightly against the first slabs.

### Booster Burner Installation:

- Once the Pizza Deck Slabs are installed as per

**INSTALLATION INSTRUCTIONS**

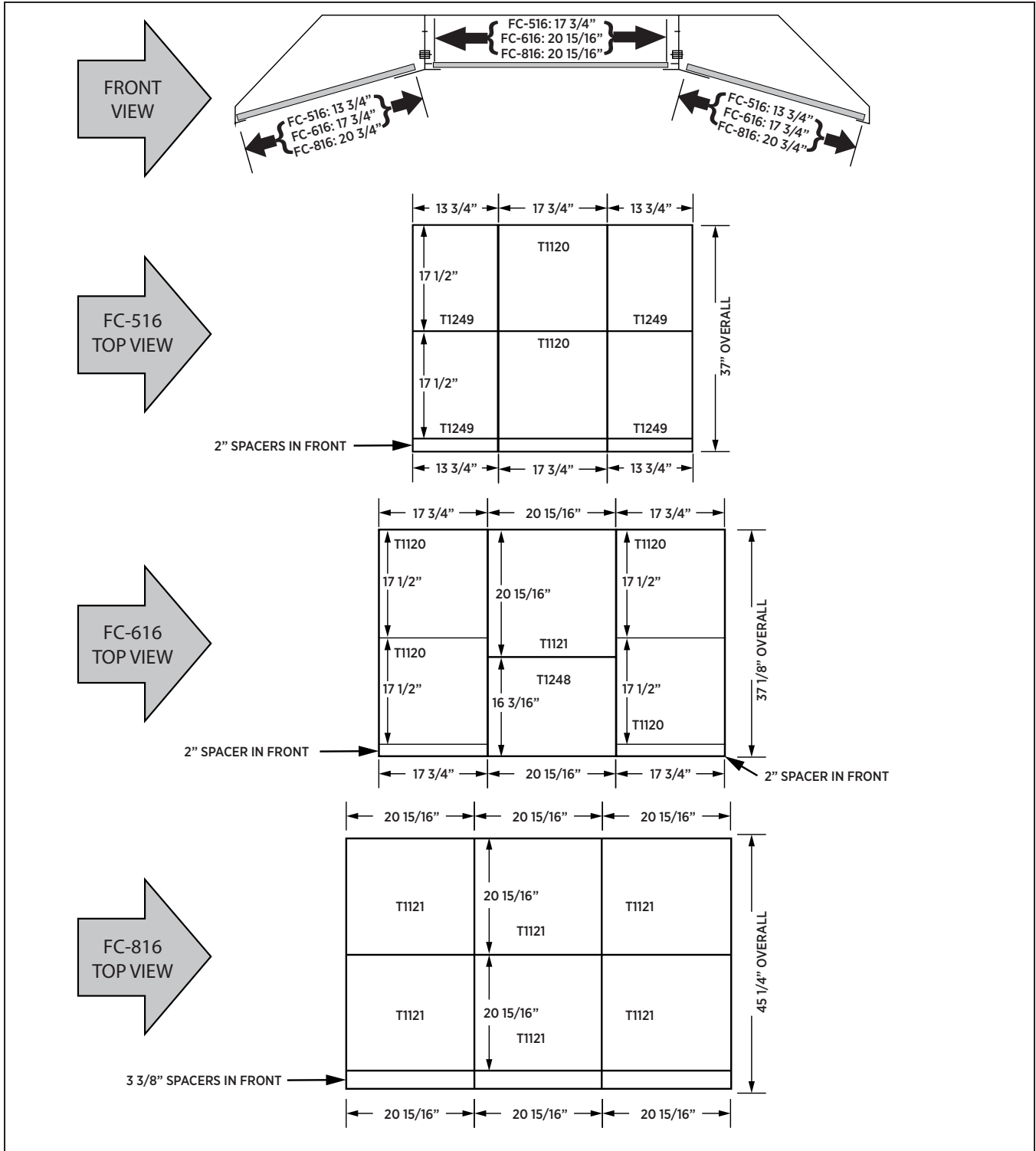

Top Brick Lining Layout



## INSTALLATION INSTRUCTIONS

instructions above, place the booster burner and guard inside the bake chamber, as far back as

### NOTICE

The Booster Burner and the Booster Burner Guard are shipped inside the burner compartment and have to be installed before the booster burner can be used for the first time.

possible, then follow with your upper torso and do the following:

- (b) Center the guard in front of the booster burner brackets, flange down, wings back, then push it all the way back and under the booster burner brackets.
- (c) Reach over the guard, slip the throat of the booster burner over the gas nozzle, then lower it and insert the two burner ends into the locating slots of the booster burner brackets and push them all the way down.

### Gas And Electric Connections:

- (a) Normal factory connections are made for 120 Volts AC, 60 Hz operation in USA and Canada. For use in Europe, the connections are made for 230 Volts AC, 50 Hz operation.

### NOTICE

Propane Gas Units are not available in the European Community.

- (b) The appliance, when installed, must be electrically grounded in accordance with local codes and/or the latest edition of the National Electric Code ANSL/NFPA 70 in USA (Canadian Electric Code CSA C22.2 in Canada).
- (c) In Europe, the appliance must be connected by an earthing cable to all other units in the complete installation and thence to an independent earth connection in compliance with EN 60335-1 and/or local codes.
- (d) The hot surface ignition system, all related switches, indicator light and fuse, are all connected through the 6 ft (1830 mm) power supply cord. The power supply cord must be plugged into a properly grounded three-

prong receptacle.

- e) A wiring diagram may be found behind the service panel on the left side of the unit and also in this manual.
- f) The ovens should not be installed on the same line

### ⚠ WARNING

Do not cut or remove the ground prong from the plug.

- with space heaters, boilers or other gas equipment with high intermittent demand.
- g) Use a pipe joint compound that is resistant to the action of liquefied petroleum gases when making gas connections.
- h) For Propane gas, use a least 1/2" pipe or tubing with a 5/8" inside diameter. For Natural gas, use 3/4" pipe.
- i) The appliance must be isolated from the gas supply piping system by closing its manual shut-off valve during any pressure testing of the gas supply piping system at test pressures equal to or less than 1/2" psig (3.45 kpa).
- j) The appliance and its shut-off valve must be disconnected from the gas supply piping system during any pressure testing of that system at test pressures in excess of 1/2" psig (3.45 kpa).
- k) The gas pressure regulators are part of the combination valves and are adjusted to yield a pressure of 3.5" water column (9 mbar) for Natural Gas. If the oven has been ordered for use on Propane Gas, the pressure regulators in the combination valves are preset at the factor to yield a pressure of 10" water column (25 mbar).
- l) A separate shut-off valve for each oven must be provided. It should be as close as possible to the place where the gas line enters the oven. It must be located where it is easily and quickly accessible.
- m) When stacking with another type of oven, two (2)

## INSTALLATION INSTRUCTIONS

shut-off valves, one for each of the two ovens, must be provided.

After the gas supply has been connected, it is extremely important to check all the piping for leaks. Use a soap and water solution or a product made expressly for this purpose. Do not use matches, candles or a flame etc. to check leaks since these methods are extremely dangerous.

### Safety Pilot Operation:

The purpose of the safety pilot system is to lock the gas supply to the burner at the combination valve, if for any reason the pilot burner is not lit. The pilot should be re-lighted by following the steps given below. However, in normal service, the pilot flame stays lit indefinitely, day and night, including weekends. This prolongs the life of the safety valve.

The safety pilot valve is in effect a two-stage control. After initial lighting, the pilot burner stays on without the gas cock dial being held pressed in. After 1-2 minutes, the valve opens fully to let the gas flow past the safety pilot valve and into the burner system.

### A. Pilot Burner Lighting Procedure:

- Partially depress and turn the gas cock dial to the "OFF" position.
- Wait for five minutes to allow gas, which may

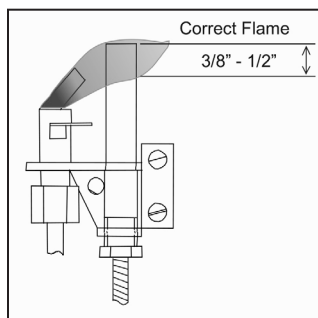

Sketch J

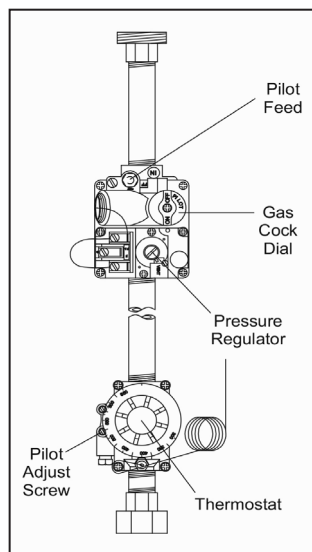

Sketch K

have accumulated in the burner compartment, to escape.

- Turn gas cock dial to "PILOT" position.
- Depress gas cock dial.
- For Main Burner: With a match or igniter light pilot burner. Hold gas cock dial in pressed position for about 1/2" minute and then release it. The Pilot Burner flame should now remain lit. If Pilot Burner fails to ignite or does not remain lit, repeat steps (a) thru (e).
- For Booster Burner: Flip toggle switch to the "ON" (I) position. The amber indicator lamp will light up and the igniter will be energized and start to glow. Hold gas cock dial in pressed position for about 2-3 minutes and then release it. The Pilot Burner flame should now remain lit. If Pilot Burner fails to ignite or does not remain lit, repeat steps (a) thru (d) and (f).

### B. Pilot Burner Flame Adjustment:

It is important to have the correct Pilot Burner Flame size as shown in (Sketch "J"). If necessary, adjust the Pilot Burner Flame by turning the Pilot Adjustment Screw (see Sketch "K") clockwise to reduce or counter-clockwise to

## NOTICE

The built-in igniter is for convenience of lighting only and not necessary for the booster burner operation. In case of power failure, or if the igniter will not light the pilot flame, the pilot flame can also be lit with a long hand-held igniter or with a long, lit taper.

increase.

### Burner Operation:

#### A. Main Burner:

After the pilot burner is ignited, when heat is desired, turn gas cock dial to the "ON" position and set the thermostat dial to the desired temperature. The oven burner flame



---

## INSTALLATION INSTRUCTIONS

should always have a blue appearance. That indicates a good mixture of gas and air. When using LP gas, the flame will have a blue-yellow appearance.

### **B. Booster Burner:**

Do not turn on the booster burner until the oven is well pre-heated and the pre-set temperature has been reached. The oven has to be hot in order to draw fresh air in to the booster burner.

After the pilot burner is ignited, when the booster burner flame is desired, turn gas cock dial to the "ON" position. The booster burner is set to have a yellow flickering flame, but should not soot.

Should the Burners fail to light, check to see if there is a problem with the gas supply. If there are other appliances on the same line, shut them off temporarily and see if the burners come back on, or they fluctuate as other gas appliances are turned on and off. That would indicate an overload of the gas supply lines or a faulty gas pressure regulator. Contact an authorized Service Agency or your local Gas Supply Company.

### **C. Aeration and By-Pass Flame Adjustment:**

Flame and air mixer adjustments for the Main Burner and the Booster Burner, and the By-Pass Flame adjustment for the Main Burner are all done at the factory. These adjustments are sealed before the oven leaves the factory. Contact an authorized Service Agency if you need help.

### **Thermostat Calibration:**

No attempt should be made to calibrate the thermostat because it is accurately calibrated and sealed by the manufacturer. Contact an authorized Service Agency if you need help.

### **Flame Diverters:**

Flame diverters distribute the heat evenly below the baking deck. They must be in good condition and properly placed above the burners in the burner chamber in order to be effective. Damaged or improperly installed flame diverters adversely affect the oven performance. Make sure that the "V- shaped" diverters are pushed all the way to the back of the oven as far as they will go. Check them periodically and replace them as necessary.



## OPERATING INSTRUCTIONS

### ⚠ WARNING

If gas odor is detected at any time, immediately shut-off the gas supply valve for the oven. Do not permit any open flames in the area of the oven. Immediately contact an authorized Service Agency or your local Gas Supply Company.

### ⚠ CAUTION

Initial heating of the oven must be done in a well ventilated area as it may generate smoke or fumes. Over exposure to smoke or fumes may cause nausea or dizziness.

#### Lighting Procedure:

- (a) Light the Main Burner following the instructions in Lighting Section of the Installation Instructions.
- (b) Keep the Push/Pull Slides fully open.

#### Breaking In:

A break-in period, after installing a new oven, is important to allow the deck and the insulation to dry out. Baking in the oven before a break-in period will result in poor performance. For breaking in:

- (a) Allow the oven to warm to 300°F (150°C) for 5 hours or at least until all the smoke and fumes have disappeared. The smoke and fumes are from the moisture in the deck and insulation and a light coat of oil on all of the sheet metal.
- (b) Set the thermostat at least 50°F (30°C) lower than your baking temperature.
- (c) Pre-heat the oven for 1 to 1 ½” hours before use.
- (d) After this pre-heating, raise the temperature to your baking temperature.
- (e) Light the Booster Burner following the instructions in Pilot Burner Flame Adjustment Section of the Installation Instructions.
- (f) Experiment baking until you get the feel of the oven and the speed of the bake.

#### Baking:

Pizza can be baked on the deck, on a screen or in a pan. When you determine the combination of method, ingredients and temperature that gives the right bake for your crust, sauce and cheese combination and your customer's taste, mark it down and keep it. Consistency is the key to repeat business.

Deck baking refers to placing the pizza directly on the deck to bake. Generally, it is a thin product that requires a high baking temperature of at least 550°F (290°C).

Screen baking refers to placing the pizza on a screen to bake. The screen keeps the pizza off the deck. The screen may be removed near the end of the bake time to give the bottom of the pizza crust a darker color. Bake temperatures range from 500°F (260°C) to 550°F (290°C).

Pan baking refers to pizza when baked in pans. Crust can be thick or thin and toppings range from light to heavy. Bake temperatures for pan baking range from 450°F (235°C) to 500°F (260°C).

#### Recommended Operating Procedure:

It is very important that at the end of day's operation, the gas cock dial of the Main Burner is turned to the pilot position, leaving only the pilot burner 'ON' overnight. Keep the Pizza Push/Pull slides fully open.

#### Pre-heating:

- (a) Turn the gas cock dial of the main burner to the 'ON' position.
- (b) Preheat the oven for 1 to 3 hours at 50°F (10°C) lower than your baking temperature, with Push/Pull Slides fully open.

#### Baking:

- (a) After pre-heating, raise the thermostat setting to your baking temperature.
- (b) Light the Booster Burner and start baking.
- (c) Check the bottom color of the Pie and close the Push/Pull slides partially (halfway) after the 4th or 5th bake to maintain the desired color.

#### Helpful Hints:



## OPERATING INSTRUCTIONS

### NOTICE

When slow or idling, open the Push/Pull slides fully and set the thermostat at least 50°F (30°C) lower than your baking temperature in order to prevent the bake deck from getting too hot.

- (a) An instructions plate is attached behind the damper knobs indicating how to set the oven for more top or more bottom heat. Opening the slides allows more heat to enter the baking chamber from the combustion / burner compartment. Closing the slides keeps more heat in the combustion / burner compartment, thereby making the bake deck hotter.
- (b) If the oven is up to bake temperature but has not been used for a while, there is a tendency for the decks to get very hot. In this condition, when you put in one pizza, TURN THE THERMOSTAT UP so that the main burner flame is at its fullest, providing the extra heat needed to balance the high bottom heat. The thermostat should be turned down back to the normal setting, as soon as that pizza is baked.
- (c) Frequently scrape and brush off decks to remove burnt residue which can cause an “off- flavor” and an

increase in the bake time.

- (d) Heavily topped pizza or pan pizza requires lower bake temperatures and longer bake times as compared to regular thin pizza with light toppings.
- (e) Bubbles in fresh dough indicate an under-proofed or cold product. Allow the dough balls to proof to double in size and warm to room temperature before baking.
- (f) Any type of pan or screen may be used in this oven. When choosing pans, be sure to pick a pan which is closest in height to that of your product.

Bakers Pride® ovens are designed to be as maintenance-free as possible. Regular and thorough cleaning

### NOTICE

Dark color Pans and Screens transfer heat better than light colored aluminum Pans or Screens. All Pans and Screens must be seasoned before use.

## CLEANING AND MAINTENANCE

### NOTICE

This appliance must be serviced only by an authorized service agent

#### Stainless Steel Surfaces:

- (a) Deposits of baked-on splatter and grease, or discoloration, may be removed with the stainless

### ⚠ CAUTION

Disconnect the power supply before cleaning or servicing the oven.

cleaner sample supplied or by using any commercial cleaner recommended for stainless steel. Bakers Pride offers a stainless steel cleaner expressly made for this purpose. RINSE WELL.

- (b) Apply a thin coat of oil to protect and enhance the finish.

#### Painted Surfaces:

- (a) Washing with mild soap and water solution is

### NOTICE

Apply stainless steel cleaner only when the oven is cold. Always rub with the grains while applying light pressure.



## CLEANING AND MAINTENANCE

adequate to keep the painted surfaces clean.

- (b) Apply a thin coat of oil to protect and enhance the finish.

### Door Mechanism:

Every six months (more frequently if the oven is used heavily) the bottom door spring mechanism and all moving parts must be inspected for wear.

### Flue Vent:

#### NOTICE

Do not apply grease to spring lever shoulder bolt, spring roller or the door rod and the door pin. They have self-lubricating inserts that will be damaged when lubricated.

and maintained clean and free of obstructions.

### Oven Interior:

Clean the oven interior only when the oven is cold. Use only the detergent solutions and cleaners that meet the national and / or local codes.

#### A. Baking Chamber:

Clean the ceiling and the walls of the baking chamber with a mild soap and water solution. Do not use oven cleaners, caustic solutions or mechanical means as they will damage the interior aluminized surface.

#### B. Baking Decks:

The baking decks are heavy and fragile. They should be handled carefully. The baking decks should be cleaned by using a long-handled scraper and stiff wire brush. At the end of each day, turn the thermostat up to its maximum setting and let the oven sit at that temperature for at least 1/2 hour. This will burn off the food spilled onto the baking decks during day's production and turn it into ash. This ash can be brushed off the next day before turning the oven on. The baking decks should be scraped and brushed during the day also to help keep them clean. To remove excessive crumbs or carbon, the baking decks and the oven cavity may be vacuumed when the oven is cold. Do not use water or other liquids on the baking decks as that may cause them

to crack. After long use, heavily soiled baking decks may be cleaned by turning over after scraping down and brushing off. This will burn off the heavily soiled side of the baking decks. This procedure may be repeated as needed.

#### (C) Burner Compartment:

Vacuum out any carbon or residue in the burner compartment and all around the bottom door. The holes and louvers on the outer surfaces of the oven must be kept free of obstructions to allow free movement of air for proper combustion and cooling of the controls.



## CLEANING AND MAINTENANCE

### Troubleshooting Chart

| PROBLEM  | PROBABLE CAUSE  | REMEDY  |
|--|---|---|
| No Pilot Light   | Gas valve feeding oven may be in the closed position  | Turn gas valve on. Relight pilot.   |
| Main Burner(s) do not light  | Gas valve feeding oven may be in the closed position  | Turn gas valve on. Relight pilot.   |
|  | Thermopile may not be positioned in pilot flame.  | Ensure that the tip of thermopile is in pilot flame.  |
|  | Thermopile may be defective   | Call local authorized Bakers Pride Service Agent.   |
| Oven too Hot   | Thermostat set too high.  | Lower the thermostat setting and see if flame reduces in size. Allow several hours for heat to regulate.  |
|  | Thermostat may be defective   | Call local authorized Bakers Pride Service Agent.   |
| Bottom of pies are undercooked   | If the same area of the deck is used repeatedly, the deck temperature in that area will be reduced. | Rotate pies to unused areas of the bake deck that are hotter and will cook the bottoms faster.  |
|  | Micro slides are open too much.   | Close micro-slides (pull out) until desired combination is reached. This will help decrease top heat  |
| Bottom of pies burn before toppings are cooked                                   | Deck temperature too hot - especially during slow periods.  | Reduce thermostat setting by 50° - 75° below normal bake temperature. When decks cool begin cooking and immediately increase the thermostat setting by 50° - 75°. |
|  | Micro slides are closed too much  | Open micro slides (push-in) to increase top heat.   |
|  | Oven was left "ON" overnight  | Oven must be turned to "Pilot" position overnight. It should not be left on a high temperature setting.   |
|  | Exhaust fan too powerful.   | Reduce fan speed.   |
| Pies cook Unevenly   | Area's adjacent to oven walls are generally hotter.   | Rotate pies (180°), once during each bake or keep to the center of oven.  |
| Oven does not turn On or Off on time. (Ovens equipped w/ auto oven starter only) | Power cord not plugged in.  | Plug unit in.   |
|  | Electrical outlet fuse/circuit breaker is tripped.  | Replace fuse or reset circuit breaker.  |
|  | Timer incorrectly set.  | Reset Timer.  |
| Rear (Booster) burner fails to light   | Electrical power has failed.  | Ensure that the power cord is still connected to a live outlet.   |
|  |   | Call local authorized Bakers Pride Service Agent.   |
| Unit takes too long to reach temp.   | Gas volume or gas pressure may be inadequate.   | Contact gas supplier.   |
|  |   | Call local authorized Bakers Pride Service Agent.   |

**WIRING DIAGRAM**

**Wiring Diagram 24V – FC SERIES – 120V, 208V or 230V, 1PH**

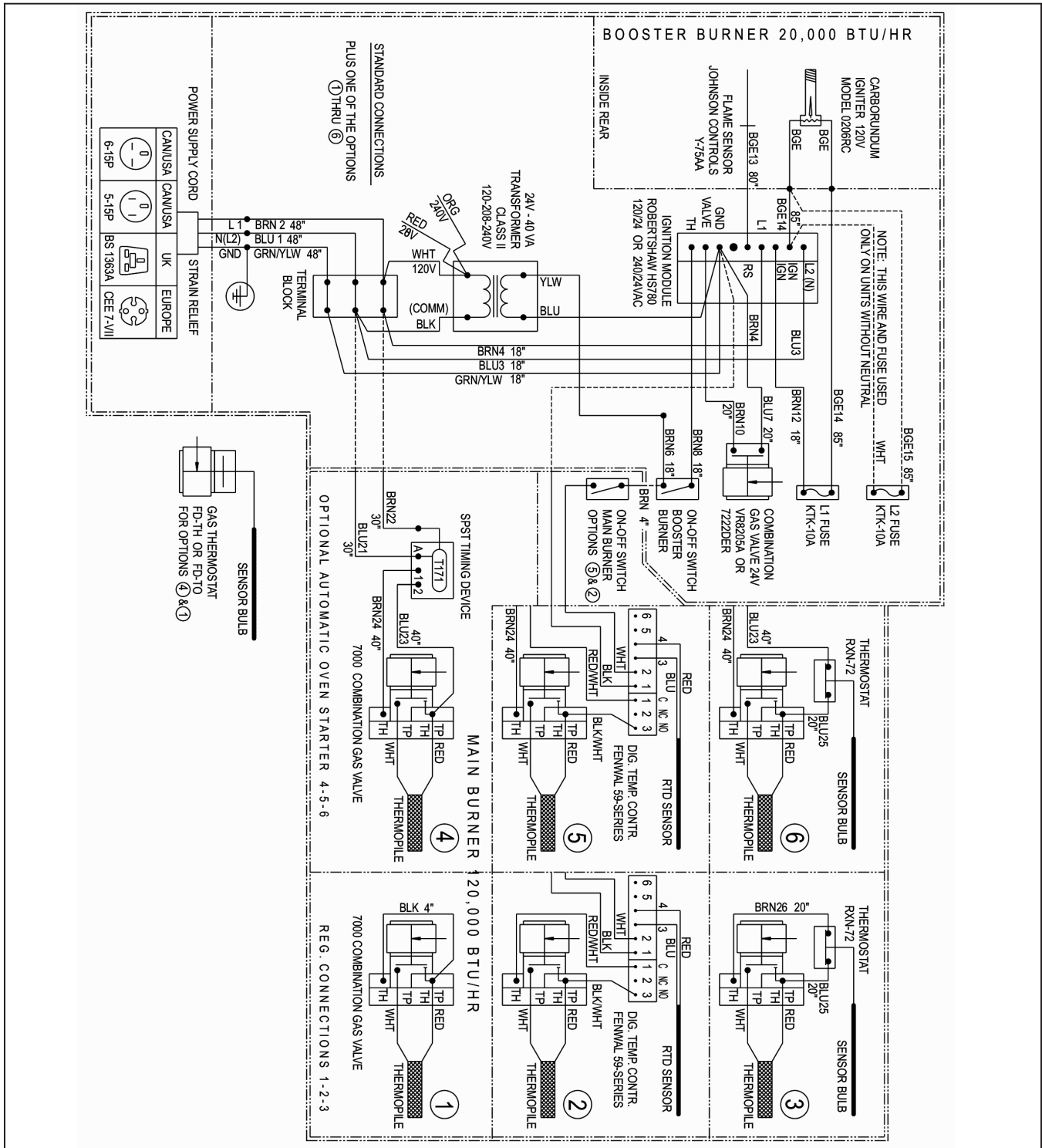



---

# BAKERS PRIDE LIMITED WARRANTY

### LIMITED EQUIPMENT WARRANTY

Baker's Pride (as well as its subsidiaries) warrants to the original purchaser of new Baker's Pride products to be free from defects in material or workmanship, under normal and proper use and maintenance service as specified by Baker's Pride and upon proper installation and start-up in accordance with the instructions supplied with each Baker's Pride unit. Baker's Pride obligation under this warranty is limited to a period of one [1] year beginning from the date of original installation. The warranty period begins upon the earlier of the date of original installation or up to six [6] months after the original shipment, from the factory, of the covered product. Defects that occur as a result of normal use, within the time period and limitations defined in this warranty, will at Baker's Pride discretion have the parts replaced or repaired by Baker's Pride or a Baker's Pride authorized service agency.

### THIS WARRANTY IS SUBJECT TO ALL LISTED CONDITIONS

Repairs performed under this warranty are to be performed by an Baker's Pride authorized service agency. Baker's Pride will not be responsible for charges incurred or service performed by non-authorized repair agencies. In all cases, the nearest Baker's Pride-authorized service agency must be used. Baker's Pride will be responsible for normal labor charges incurred in the repair or replacement of a warrantied product within 50 miles (80.5 km) of an authorized service agency. Time and expense charges for anything beyond that distance will be the responsibility of the owner. All labor will need to be performed during regular service hours. Any overtime premium will be charged to the owner. For all shipments outside the U.S.A. and Canada, please see the International Warranty for specific details. It is the responsibility of the owner to inspect and report any shipping damage claims, hidden or otherwise, promptly following delivery. No mileage or travel charges will be honored on any equipment that is deemed portable. In general, equipment with a cord and plug weighing less than 50 lb. (22.7 kg) is considered portable and should be taken or shipped to the closest authorized service agency, transportation prepaid.

### CONTACT

Should you require any assistance regarding the operation or maintenance of any Baker's Pride Manufacturing; phone or email our service department. In all correspondence provide the model number and serial number of the unit needing service; include the voltage or gas type. Normal Business Hours: 8:00 a.m. to 5:00 p.m. Central  
Telephone: 800-773-2203 Tech Service Option 2  
Email: [TechService@partstown.com](mailto:TechService@partstown.com)  
[www.bakerspride.com](http://www.bakerspride.com)

### WARRANTY EXCLUSIONS

#### THE FOLLOWING WILL NOT BE COVERED UNDER WARRANTY.

Baker's Pride sole obligation under this warranty is limited to either repair or replacement parts, subject to the additional limitations detailed below. This warranty neither assumes nor authorizes any person to assume obligations other than those expressly covered by this warranty.

- Any product which has not been used, maintained, or installed in accordance with the directions published in the appropriate installation sheet and/or owner's manual, including incorrect gas or electrical connection. Baker's Pride is not liable for any unit which has been mishandled, abused, misapplied, subjected to harsh chemicals, modified by unauthorized personnel, damaged by flood, fire, or other acts of nature [or God], or which have an altered or missing serial number.
- Installation, labor, and job checkouts, calibration of heat controls, air and gas burner/bypass/pilot adjustments, gas or electrical system checks, voltage and phase conversions, cleaning of equipment, or seasoning of griddle surface.
- Replacement of fuses or resetting of circuit breakers, safety controls, or reset buttons.
- Replacement of broken or damaged glass components, quartz heating elements, and light bulbs.
- Labor charges for all removable and consumable parts in gas charbroilers and hotplates, including but not limited to burners, grates, and radiants.
- Any labor charges incurred by delays, waiting time, or operating restrictions that hinder a service technician's ability to perform service.
- Replacement of parts that fail or are damaged due to normal wear or labor for replacement of parts that can be replaced during a daily cleaning routine, such as but not limited to silicone belts, PTFE non-stick sheets, control labels, knobs, bulbs, fuses, quartz heating elements, baskets, racks, and grease drawers.
- Any economic loss of business or profits.
- Non-OEM parts. Use of non-OEM parts without Baker's Pride approval will void the warranty.
- Units exceeding one [1] year from original installation date.

### ADDITIONAL WARRANTIES

- Specific/chain-specific equipment may have additional and/or extended warranties.

The foregoing warranty is in lieu of any and all other warranties expressed or implied and constitutes the entire warranty.



265 Hobson St. • Smithville, TN 37166  
Phone 800.527.2100 | [bakerspride.com](http://bakerspride.com)

Be sure to keep up with new product  
announcements and events on social media!

