

**TURBOCHEF**™

**OWNER'S MANUAL**

**FIRE ARTISAN PIZZA OVEN**



TABLE OF CONTENTS

- 1. REVISION HISTORY ..... 5
- 2. IMPORTANT SAFETY INSTRUCTIONS ..... 6
  - 2.1 General Safety Information ..... 6
  - 2.2 Reducing Fire Risk ..... 7
  - 2.3 Grounding Instructions ..... 8
  - 2.4 Power Cord Replacement ..... 8
  - 2.5 Protective Earth (Ground) Symbol ..... 8
  - 2.6 Equipotential Bonding Symbol ..... 8
- 3. SPECIFICATIONS ..... 9
  - 3.1 Performance ..... 9
  - 3.2 Dimensions ..... 9
  - 3.3 Certifications ..... 10
  - 3.4 Oven Construction ..... 10
  - 3.5 Electrical Specifications ..... 10
- 4. INSTALLATION ..... 11
  - 4.1 Unpacking Instructions ..... 11
  - 4.2 Lifting and Placing Oven ..... 11
  - 4.3 Oven Handle Installation ..... 11
  - 4.4 Installation Near Open Heat Source ..... 12
  - 4.5 Voltage Selection ..... 13
  - 4.6 Ventilation ..... 13
- 5. CLEANING ..... 14
  - 5.1 Daily Maintenance ..... 14
  - 5.2 Supplies and Equipment ..... 14
- 6. OVEN CONTROLS ..... 16
  - 6.1 Cooking ..... 17
  - 6.2 Setting Temperature ..... 17

- 6.3 Setting Timers ..... 17
- 6.4 Setting Parameters ..... 18
- 7. TROUBLESHOOTING ..... 20
- 8. INTERNATIONAL LIMITED WARRANTY ..... 21
  - 8.1 Limited Warranty ..... 21
  - 8.2 Disclaimer ..... 21
  - 8.3 TurboChef Global Warranty System ..... 21
  - 8.4 Warranty Service ..... 22

For further information, call  
800.90TURBO  
*or*  
+1 214.379.6000

## 1. REVISION HISTORY

Revision	Revision Date	By	Revision Description
A	30-Feb-26	BA	<ul style="list-style-type: none"> <li>• Updated Disclaimer section</li> <li>• New template, updated version FRE-1001 Rev J</li> <li>• Clarified full-height partition requirement and installation</li> <li>• Updated fire oven dimensions to include side dimensions between feet</li> <li>• Updated graphics</li> </ul>

## 2. IMPORTANT SAFETY INSTRUCTIONS

This manual provides essential information for installing, operating, maintaining, and servicing this oven. Information and specifications are subject to change without notice. Retain for future reference.

### ⚠️ WARNINGS:

- **When operating this oven, strictly adhere to the following safety precautions to reduce the risk of burns, electric shock, fire, injury, or damage to the oven or property near the oven.**
- **This appliance has hot surfaces! During use, the accessible parts of the oven can become very hot. When opening the oven door during or after cooking, be careful of the airflow and any steam released from the cooking chamber. Step to the side or back.**

### 2.1 General Safety Information

- ✓ To ensure proper use of the appliance, read all parts of this manual carefully and store it safely. Before using the appliance, clean all surfaces that will come into contact with food.
- ✓ Read all instructions before using this appliance.
- ✓ This appliance must be grounded. Connect only to a properly grounded outlet. Refer to the [Grounding Instructions](#) section.
- ✓ Install or locate this appliance only in accordance with the provided installation instructions.
- ✓ This appliance should be serviced by qualified service personnel only. Contact the nearest authorized service facility for examination, repair, or adjustment.
- ✓ Keep the cord away from heated surfaces.
- ✓ Use this appliance only for its intended uses as described in this manual.
- ✓ This appliance is designed for professional use. Only allow qualified or duly instructed personnel to use.
- ✓ Always monitor the appliance during operation.
- ✓ In the event of a failure, breakage, or irregular function, switch the appliance off and disconnect the oven from the power supply.
- ✓ Always ensure the oven is disconnected from the power supply before servicing, repairing, or adjusting any components or parts.
- ✓ This appliance is not to be used by children or persons with reduced physical, sensory, or mental capabilities, or a lack of experience and knowledge, unless a responsible person has given them supervision or instruction.

⚠️ **WARNING: Due to the nature of the appliance, the floors around it may be slippery.**

DO NOT perform the following:

- ✘ Use corrosive chemicals or vapors in this appliance; it is not designed for industrial/laboratory use.
  - ⚠ **WARNING: Do not heat liquids or other foods in sealed containers (e.g., jars, whole eggs, etc.) because they can explode.**
- ✘ Allow children to use this appliance.
- ✘ Operate this appliance if it has a damaged cord or plug, is not working properly, has been damaged, or dropped. Refer to the [Power Cord Replacement](#) section.
- ✘ Cover or block any openings on this appliance.
- ✘ Store this appliance outdoors.
- ✘ Use this appliance near water (e.g., a kitchen sink, a wet basement, or a swimming pool).
- ✘ Immerse the cord or plug in water.
- ✘ Let the cord hang over the edge of a table or counter.
- ✘ Place the cord near heated surfaces.
- ✘ Store or use flammable vapors or liquids (e.g., gasoline) in the vicinity of this appliance.
- ✘ Use a water jet for cleaning. See page 5 in this manual for proper cleaning procedures.

## 2.2 Reducing Fire Risk

- ✓ If materials inside the oven ignite, keep the oven door closed, turn the oven off, and disconnect the power cord or shut off power at the fuse or circuit breaker panel.
- ✓ If smoke is observed, switch off or unplug the oven. Keep the door closed to stifle any flames.

DO NOT perform the following

- ✘ Put plastic or paper bags in the oven.
- ✘ Use the cook cavity for storage purposes.
- ✘ Overcook food. Carefully attend to the oven if paper, plastic, or other combustible materials are placed inside to facilitate cooking.
- ✘ Leave paper products, cooking utensils, or food in the cavity when the oven is not in use.

### 2.3 Grounding Instructions

This appliance must be grounded. In the event of an electrical short circuit, grounding reduces the risk of electric shock by providing an escape wire for the electric current. This oven is equipped with a cord with a grounding wire and a grounding plug, which must be plugged into an outlet that is properly installed and grounded. Consult a qualified electrician or serviceman if uncertain about the ability to follow grounding instructions or if doubt exists as to whether the appliance is properly grounded.

**⚠ WARNING: Improper grounding can result in risk of electric shock.**

- ✖ Do not use an extension cord. If the power cord is too short, have a qualified electrician or serviceman install an outlet near the appliance.

### 2.4 Power Cord Replacement

If the power cord is damaged, it must be replaced by the manufacturer, its service agent, or a similarly qualified person.

**⚠ WARNING: If the oven is unplugged during service or maintenance, the user must always be able to access and see the plug to ensure that the oven remains unplugged. The plug must remain near the oven and cannot be placed behind another appliance or in another room.**

### 2.5 Protective Earth (Ground) Symbol



This symbol identifies the terminal intended for connecting an external conductor to protect against electric shock in case of a fault, or the terminal of a protective earth (ground) electrode.

### 2.6 Equipotential Bonding Symbol



This symbol identifies terminals that, when connected, bring the various parts of an equipment or system to the same potential, not necessarily the earth (ground) potential, e.g., for local bonding.

### 3. SPECIFICATIONS

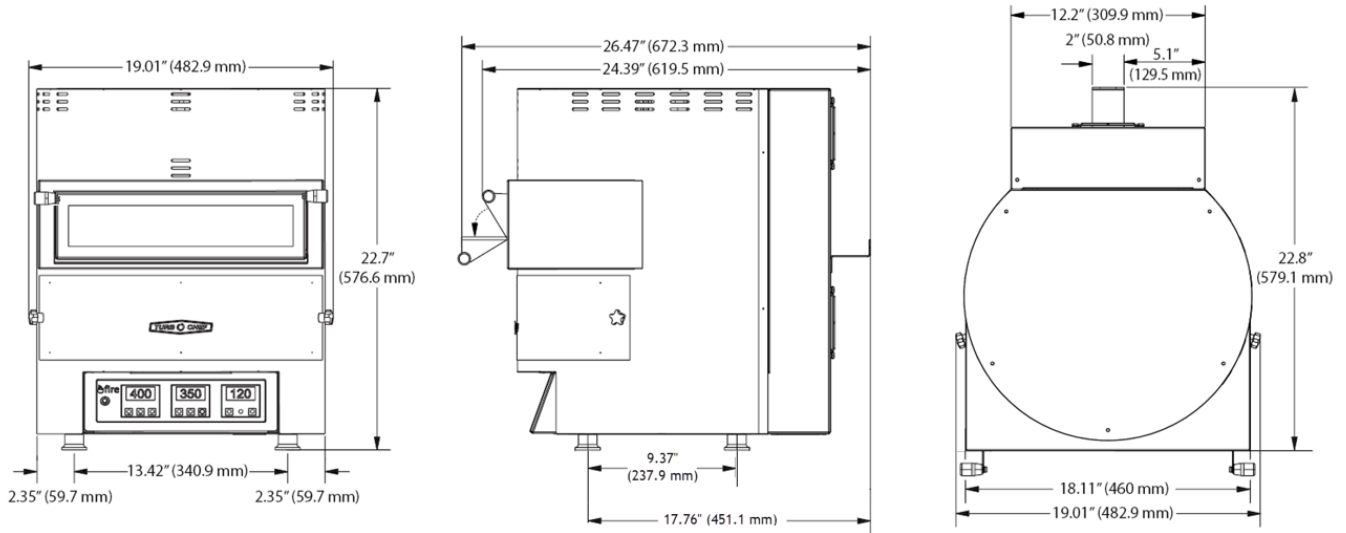

Figure 3-1: Fire Oven Dimensions

#### 3.1 Performance

The TurboChef Fire provides the artisan hearth-style pizza experience anywhere. Cooking at 842 °F/450 °C, the Fire can cook 14-inch fresh dough pizzas in as little as 90 seconds. The oven is small and ventless, so it can be placed virtually anywhere without requiring Type I or Type II ventilation. This manual includes instructions for installing, cleaning, and operating the Fire oven. If you have questions that are not addressed in this manual, contact Customer Support at 800.90TURBO (+1 214.379.6000) or your authorized distributor.

#### 3.2 Dimensions

Oven Dimensions	
Height	22.7" (576.6 mm)
Width	19.01" (482.9 mm)
Depth	
Footprint	18.55" (471.2 mm)
Door closed	24.39" (619.5 mm)
Door open	26.47" (672.3 mm)
Weight	75 lb (34 kg)
Cook Cavity Dimensions	
Width	14.75" (374.7 mm)
Depth	14.75" (374.7 mm)
Clearances	
Top	2" (51 mm)
Sides	2" (51 mm)

### 3.3 Certifications

cULus, UL EPH, TÜV, CE



### 3.4 Oven Construction

- Exterior
  - Powder-coated, corrosion-resistant steel outer wrap
  - 430 stainless steel construction
- Interior
  - 430 stainless steel interior

### 3.5 Electrical Specifications

TurboChef recommends a Type D circuit breaker for all installations outside the United States.

#### Single Phase

North America: 208/240 VAC, 50/60 Hz, 3700/4800 W,  
18/20 A, 30 A Plug

Europe/Asia/South America: 230 VAC, 50/60 Hz, 4500 W,  
19.6 A, 32 A Plug

Europe/Australia: 230 VAC, 50/60 Hz, 4500 W,  
11.5/1.4/9.2 A, 20 A Plug

## 4. INSTALLATION

Install or locate this appliance only in accordance with the instructions below.

### ⚠️ WARNINGS:

- The Fire weighs approximately 75 lb (34 kg). Never lift with fewer than two people.
- The oven must be appropriately placed on a food station at all times. TurboChef will not recognize a fallen oven as a warrantable claim and is not liable for any injuries that may result.
- This oven is not intended for built-in installation (i.e., installing the oven in any structure that surrounds the oven by five or more sides). Be sure to provide a minimum of 2" (51 mm) clearance on all sides and 2" (51 mm) at the top.
- This oven is not intended to be stacked.

### 4.1 Unpacking Instructions

1. Remove the oven from its packaging.
2. Before discarding, check the packaging thoroughly for accessories and literature.  
*Note: Keeping the packaging is recommended in case the oven may be shipped to another location.*
3. Check the cook cavity thoroughly for packaging, accessories, and literature.
4. Discard any packaging in the cook cavity.

### 4.2 Lifting and Placing Oven

1. Prepare a surface at least 18.55" (471.2 mm) deep and capable of supporting 80 lb (36.3 kg).  
*Note: Do not remove the oven legs.*
2. Position one or more persons at the left and right sides of the oven.
3. Place your hands under the oven and lift.
4. Place the oven on the prepared surface, ensuring no edges are hanging off the sides.
5. Ensure the lower access panel is installed correctly (thumbscrews are tight).
6. Plug in the oven after installation is finished.

### 4.3 Oven Handle Installation

1. While the oven is off and cool, open the oven door.
2. Using a Phillips head screwdriver, remove the two screws on the right side of the oven door.

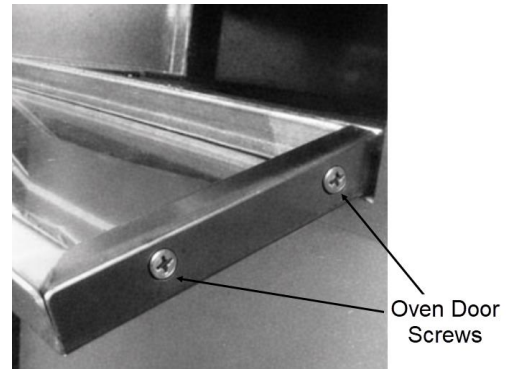

3. Install the handle bracket using the screws removed in step 2.



4. Close the oven door.
5. Attach the handle to the bracket using the provided screw and washer.

**CAUTION: Avoid over-tightening the handle, as this could cause it to break.**

6. Repeat this process for the left side.

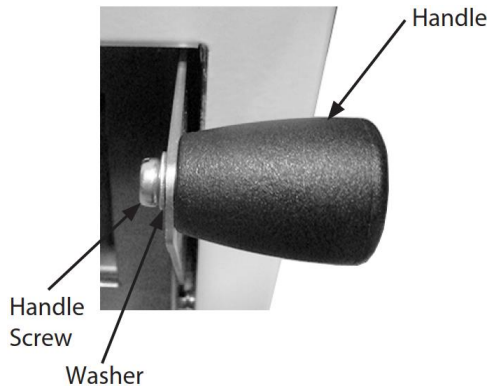

#### 4.4 Installation Near Open Heat Source

When placing a TurboChef oven near an open heat source (see [Figure 4-1](#)), strictly adhere to the following:

Verify that the oven location has a minimum of 2" (51 mm) of clearance above and a minimum of 2" (51 mm) on each side.

*Note: The height of the divider must be greater than or equal to the height of the oven (22.7" or 576.6 mm).*

If	Then
The oven is being placed near a grill or stove	A divider must exist between the oven and the open heat source, with a minimum of 6" (152 mm) between the oven and the divider.
The oven is being placed near a fryer	A divider must exist between the oven and fryer, with a minimum of 12" (305 mm) between the oven and the divider.

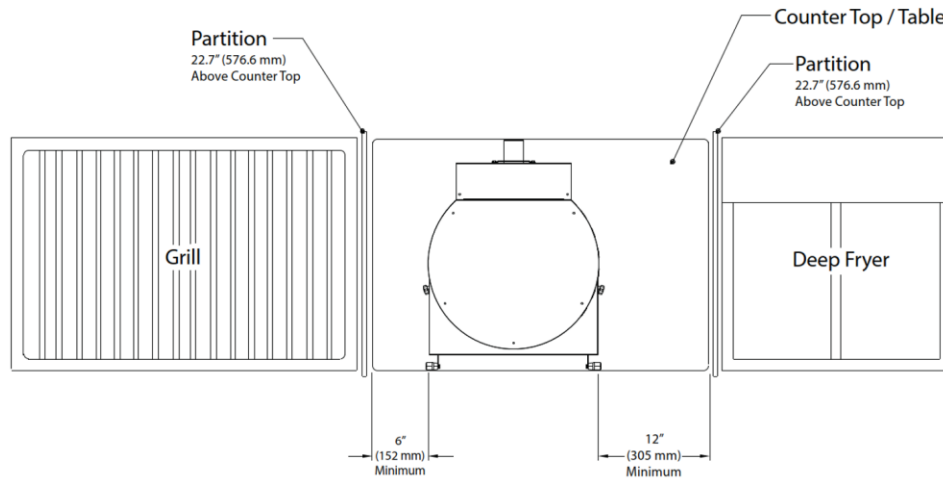

Figure 4-1: Installation Near Open Heat Source

*Note: Partition shall extend the full height of the oven. The dimension shown (22.7 in / 576.6 mm) indicates the minimum required vertical clearance above the countertop. Installation assumes adjacent appliances are installed on the same countertop elevation.*

## 4.5 Voltage Selection

For North American oven models, the oven will detect 208 or 240 V.

## 4.6 Ventilation

Underwriter's Laboratory LLC has approved the TurboChef Fire oven for ventless operation (UL® KNLZ listing) for all food items except for foods classified as "fatty raw proteins." Such foods include bone-in, skin-on chicken, raw hamburger meat, raw bacon, raw sausage, steaks, etc. If cooking these types of foods, consult local HVAC codes and authorities to ensure compliance with ventilation requirements

To ensure continued compliance with all health, building, and fire codes, you must maintain clean, sanitary conditions around your oven at all times.

*Note: The manufacturer is not responsible for damages or injuries caused by installations that do not follow the listed instructions and codes. Failing to follow these instructions may result in a temporary cease-and-desist order from the local health department until environmental concerns are resolved.*

## 5. CLEANING

### 5.1 Daily Maintenance

Follow the steps below when cleaning your Fire oven. Use only TurboChef®-approved cleaning chemicals. Using any other cleaning products may damage critical oven components, resulting in a non-warranty service call.

### 5.2 Supplies and Equipment

TurboChef®-approved oven cleaner; nylon scrub pad, cleaning towel, disposable gloves, protective eyewear, dust mask (optional).

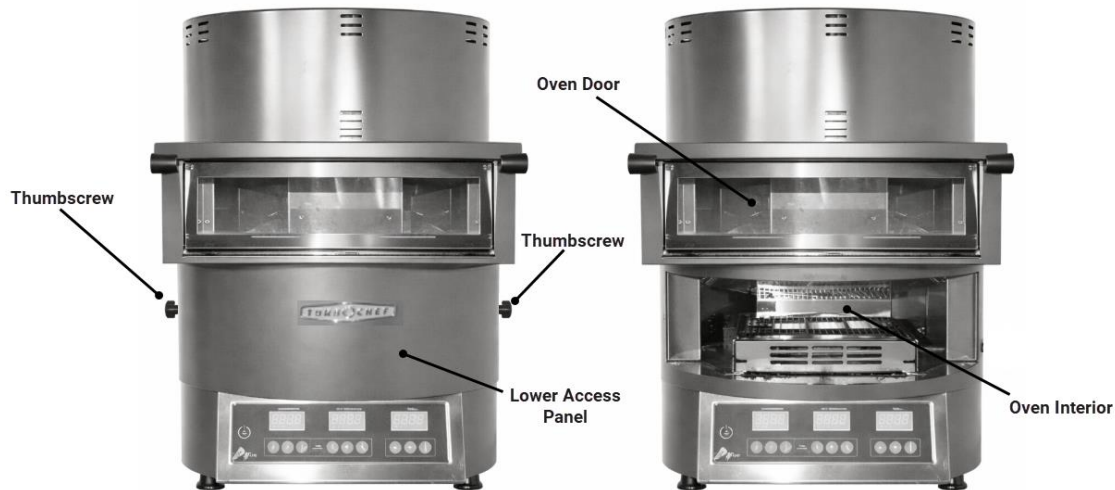

Figure 5-1: Maintenance

1. Cool the oven

**⚠ WARNING: The oven operates at approximately 842 °F (450 °C) and may cause injury if not allowed to cool properly.**

- a. Turn off the oven by pressing the **ON/OFF** button.
- b. Cooling takes approximately two hours (or longer). **DO NOT** clean the oven until it is cool.

2. Wipe the oven interior

- a. Remove the lower access panel by removing the two thumbscrews.
- b. Use a food vacuum or a damp towel to remove large particles from the oven interior.

3. Clean the oven interior

- a. Spray TurboChef®-approved oven cleaner onto a clean towel or nylon scrub pad.

**CAUTION: Do not spray oven cleaner into cavity openings. Spraying oven cleaner into cavity openings causes damage to critical oven components, resulting in a non-warranty service call.**

- b. Open the oven door and gently wipe down the inside of the door.
- c. For stubborn stains, lightly spray oven cleaner on the stain and allow the cleaner to penetrate for five minutes, then wipe clean.

4. Rinse or wipe the oven interior
  - CAUTION: Do not use a hose or water jet for cleaning. Doing so can damage critical oven components, resulting in a non-warranty service call.**
  - a. Wipe down the oven cavity with a damp towel.
  - b. Dry the oven cavity with a dry towel.
5. Clean the oven exterior
  - a. Reinstall the lower access panel and secure it with the two thumbscrews.
  - b. Wipe the oven exterior with a damp towel.
    - CAUTION: Do not spray oven cleaner into cavity openings. Spraying oven cleaner into cavity openings causes damage to critical oven components, resulting in a non-warranty service call.**
  - c. The oven is ready for operation.

## 6. OVEN CONTROLS

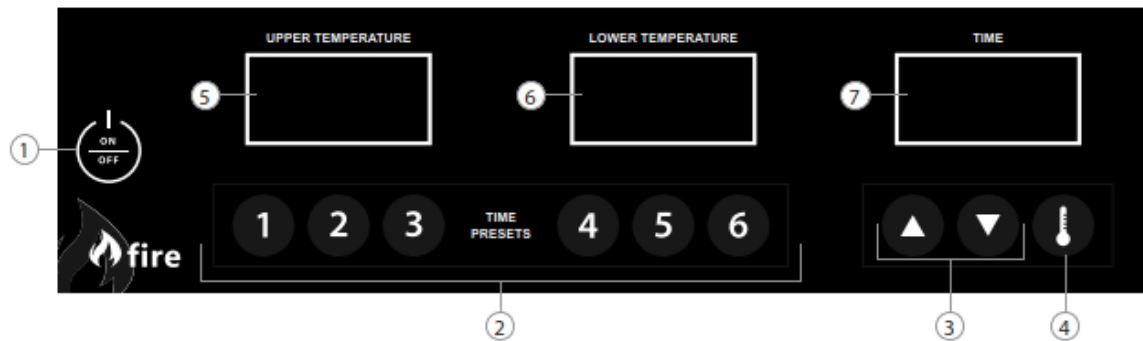

1. **ON/OFF button.**  
Press to turn the oven on or off.
2. **Time Preset Keys**  
Press presets 1 through 6 to activate a timer.
3. **Up and Down Keys**  
Press the up and down keys to change the [oven temperature](#), the [time presets](#), or the [parameters](#).
4. **Temperature Key**  
Press the Temperature Key to toggle between the upper and lower temperature settings.
5. **Upper Temperature Display**  
Displays the current Upper Temperature. A green light in the lower-left corner of this display will blink during warm-up and turn solid once it reaches the set temperature.
6. **Lower Temperature Display**  
Displays the current Lower Temperature. A green light in the lower-left corner of this display will blink during warm-up and turn solid once it reaches the set temperature.
7. **Time Display**  
Shows the remaining time for the selected preset. The time is displayed in seconds, up to 1,999 (33 minutes and 19 seconds).

## 6.1 Cooking

1. Press the **ON/OFF** button to turn the oven on.
2. Allow the oven to warm up.  
*Note: The green light in the bottom-left corner of the **Upper Temperature** and **Lower Temperature** display will blink during warm-up. Once the oven has finished warm-up, the lights will stop flashing and stay solid.*
3. Open the oven door.
4. Using the provided paddle and cooking screen, slide the product into the oven and close the oven door.
5. Press the desired timer (1 through 6).  
*Note: Once the timer reaches 0, the oven will start beeping. To stop the beeping, press any **Time Preset** key.*
6. Open the oven door, remove the product from the oven, and close the oven door.  
**CAUTION: Dish and inside of oven/oven door are hot!**
7. Once finished cooking for the day, press the **ON/OFF** button to turn off the oven and start cooling down.

## 6.2 Setting Temperature

Two different temperatures can be set: one for the upper heating zone and one for the lower heating zone. These temperatures range from off to 842 °F (450 °C).

*Note: When a temperature is set to off, the display will read 32 °F (0 °C).*

1. While the oven is on, press the Temperature key to access the upper temperature (the upper temperature will begin flashing).
2. Use the up and down keys to set the upper temperature.

3. Press the Temperature key again to save the upper temperature and to access the lower temperature.
4. Use the up and down keys to set the lower temperature.
5. Press the Temperature key again to save the lower temperature.  
*Note: If changing only one temperature, press the Temperature key to bypass the upper or lower temperature without changing it.*

## 6.3 Setting Timers

Six timers can be configured to support different items.

1. Set a timer:
  - a. Make sure no timers are running.
  - b. While the oven is on, press and hold the desired timer button (1 through 6) for two seconds. The value indicated on the **Time** display will begin flashing.
  - c. Use the up and down keys to set the time.
  - d. Press and hold the same timer button for two seconds to save the time.  
*Note: If you wait five seconds without pressing any buttons, the timer will save automatically.*
2. Pause a timer:
  - a. Press any of the Time Preset keys. The Time Display will flash to indicate that the timer is paused.
  - b. To resume the timer, press any of the Time Preset keys again.

- c. To reset the timer to 0, press and hold any of the Time Preset keys for two seconds. The oven will begin beeping to indicate the timer has reached zero.
- d. To stop the beeping, press any of the Time Preset keys.

- 2. Press the Down key until the **Time** display reads **-19**.
- 3. Simultaneously press and hold the Time Preset 2 and 3 keys for two seconds. The **Upper Temperature** display will now read **P0**.
- 4. Refer to the table below and use the Time Preset 2 and 3 keys (increase and decrease parameter numbers) to navigate through the parameters.
- 5. Use the Up and Down keys to change values.
- 6. When finished, press the **ON/OFF** button.

### 6.4 Setting Parameters

Access the parameter settings to change oven options.

- 1. While the oven is off, simultaneously press and hold the **Time Preset 2** and **3** keys for two seconds. The **Upper Temperature** display will read **PA**.

Parameter	Description	Unit of Measure	Minimum Value	Maximum Value	Values for US Configurations	Values for AK, AU, EW, and UK Configurations
P0	Temperatures shown in °C or °F (0 = °C, 1 = °F)	n/a	0	1	1	0
P1	Temperature Displays (0 = Actual, 1 = Setpoint)	n/a	0	1	0	0
P2	Hysteresis Setting for Thermostat	°F/°C	36 °F/2°C	48 °F/9 °C	4 °F/2 °C	4 °F/2 °C
P3	Offset of Top RTD °	°F/°C	-22 °F/-30°C	86 °F/30 °C	0 °F/0 °C	0 °F/0 °C
P4	Set Point Regulator (Top)	°F/°C	P5	P6	212 °F/100 °C	212 °F/100 °C
P5	Minimum Setting of Heater 1 °	°F/°C	32 °F/0 °C	P6	122 °F/50 °C	122 °F/50 °C
P6	Maximum Setting of Heater 1	°F/°C	P5	842 °F/450 °C	842 °F/450 °C	842 °F/450 °C
P7	Offset of Bottom RTD °	°F/°C	-22 °F/-30 °C	86 °F/30 °C	0 °F/0 °C	0 °F/0 °C
P8	Set Point Regulator (Bottom)	°F/°C	P9	P10	212°F/100 °C	212 °F/100 °C
P9	Minimum Setting of Heater 2	°F/°C	32 °F/0 °C	P10	122 °F/50 °C	122 °F/50 °C
P10	Maximum Setting of Heater 2	°F/°C	P9	842 °F/450 °C	842 °F/450 °C	842 °F/450 °C
P11	Cooling Fans Off Delay (K5 Relay)	Minutes	0	60	30	30
P12	Fan 1 and 2 Off Delay (K6 Relay)	Minutes	0	60	30	30
P13	Keyboard Cooling Fan Off Delay (K7 Relay)	Minutes	0	60	30	30
P14	Preset Timer 1	Seconds	P20	P21	80	80
P15	Preset Timer 2	Seconds	P20	P21	90	90

Parameter	Description	Unit of Measure	Minimum Value	Maximum Value	Values for US Configurations	Values for AK, AU, EW, and UK Configurations
P16	Preset Timer 3	Seconds	P20	P21	100	100
P17	Preset Timer 4	Seconds	P20	P21	110	110
P18	Preset Timer 5	Seconds	P20	P21	120	120
P19	Preset Timer 6	Seconds	P20	P21	130	130
P20	Minimum Settable Time	Seconds	0	P21	0	0
P21	Maximum Settable Time	Seconds	P20	1,999	240	240
P22	Duration of Buzzer Sound	Seconds	0	60	15	15
P23	Enable Over Temperature Alarm (0 = Disable, 1 Enable)	n/a	0	1	0	0
P24	Over Temperature Alarm Threshold	°F/°C	131 °F/ 55 °C	158 °F/70 °C	140 °F/60 °C	140 °F/60 °C
P25	Heater Modulation (0 = None, 1 = Voltage Module determines)	n/a	0	1	1	0
P26	Heat Cycle Time	Seconds	1	999	60	60
P27	Top Heater On Percentage	%	0	100	100	100
P28	Bottom Heater On Percentage	%	0	100	100	100
P29	Time between selection and timer start	Seconds	2	20	2	2

OVEN CONTROLS

## 7. TROUBLESHOOTING

The following is a list of issues, along with the possible cause(s), that the oven may be experiencing. Please attempt the recommended resolution before calling Customer Support (800.90TURBO, +1 214.379.6000) or your Authorized Distributor. If any issue occurs that is not listed below, contact Customer Support (800.90TURBO, +1 214.379.6000).

**CAUTION: Food, oven door, and oven cavity are hot!**

Issue	Possible Cause(s)	Resolution
No power to oven	<ul style="list-style-type: none"> <li>Oven is not plugged in.</li> <li>Main circuit breaker is tripped.</li> </ul>	<ul style="list-style-type: none"> <li>Plug oven in.</li> <li>Verify the wall circuit breaker is on.</li> <li>Reset the breaker and then power the oven back on.</li> </ul>
Oven is not warming up properly	<ul style="list-style-type: none"> <li>Oven is in the off state</li> <li>Oven has been switched off at the main circuit breaker</li> <li>High-limit thermostat tripped.</li> </ul>	<ul style="list-style-type: none"> <li>Press the <b>ON/OFF</b> button.</li> <li>Unplug the oven:                             <ul style="list-style-type: none"> <li>Leave for two minutes.</li> <li>Re-plug in the oven</li> <li>Switch on the isolator/main power supply.</li> <li>Press the <b>ON/OFF</b> button.</li> </ul> </li> <li>Press the button in the back-left corner of the oven's base to reset the high-limit thermostat.</li> </ul>
Oven is not cooking properly	<ul style="list-style-type: none"> <li>Oven is not clean.</li> <li>Incorrect Time Preset was selected for the product.</li> <li>The temperature is not correct.</li> <li>Product was not cooked from the correct starting state (for example, chilled or frozen).</li> </ul>	<ul style="list-style-type: none"> <li>Clean the oven, refer to the <a href="#">Cleaning</a> section.</li> <li>Check to make sure the correct Time Preset was selected for the product.</li> <li>Check to make sure the temperature is set correctly.</li> <li>Ensure product was in the correct state before being placed in the oven</li> </ul>
Er1, Er2, or Ht Error Codes	Defective component	Contact TurboChef for service.

TROUBLESHOOTING

## 8. INTERNATIONAL LIMITED WARRANTY

This Limited Warranty shall apply to the sales of all TurboChef Fire ovens (the "Equipment") to purchasers outside of the United States, Canada, Puerto Rico, Central and South America by an Authorized Distributor of TurboChef International (the "Authorized Distributor").

### 8.1 Limited Warranty

You, the purchaser ("You"), have entered into a sales contract with the Authorized Distributor for the purchase of the Equipment. This Limited Warranty is provided to you by the Authorized Distributor from whom you purchased the Equipment, with support from TurboChef Technologies, Inc. ("TurboChef"). Subject to the limitations below, the Authorized Distributor guarantees that the quantity and specifications of the Equipment delivered to you will match those outlined in the Authorized Distributor's acceptance of your order, and that the Equipment will be free from material defects in both product and workmanship for twelve months from the installation date (the "Warranty Period"), subject to the terms and conditions specified herein.

### 8.2 Disclaimer

You acknowledge that You are solely responsible for the selection of the Equipment and determining the suitability of the Equipment for Your needs. All other warranties, conditions, or terms related to the fitness for purpose, quality, or condition of the Equipment, whether expressed or implied by statute or common law or otherwise, are excluded to the fullest extent permitted by law.

Paint and surface finishes are excluded from coverage under the standard limited warranty.

### 8.3 TurboChef Global Warranty System

This Limited Warranty begins when the Equipment is delivered to Your location. The Authorized Distributor will inspect and install the Equipment at Your site following TurboChef's instructions and will record the Equipment's serial number, Your contact information, the date and location of installation, and the results of the Authorized Distributor's inspection. This information will be entered into the TurboChef global warranty system and used by TurboChef, the Authorized Distributor, and authorized service agents for warranty services.

## 8.4 Warranty Service

During the Warranty Period, TurboChef will repair or replace any significantly defective Equipment free of charge, at its discretion, as long as you notify the Authorized Distributor who sold you the Equipment and/or TurboChef promptly after discovering the defect and follow the warranty claims process described below:

- You provide the Authorized Distributor from whom You purchased the Equipment and/or TurboChef with all data and information reasonably requested by TurboChef, the Authorized Distributor, or its authorized service agents in connection with your warranty claim;
- You make the Equipment available to TurboChef, the Authorized Distributor, or its authorized service agents;
- An Authorized Distributor has installed the Equipment, and You have provided all necessary information for the Authorized Distributor to register the Equipment in the TurboChef global warranty system;
- The Equipment has been operated and maintained by You in accordance with TurboChef's "Owner's Manual" provided with the Equipment (and as updated by TurboChef);
- You have not used any non-approved devices, accessories, consumables, or parts in conjunction with the Equipment; and
- Repairs, modifications, or alterations have only been performed by TurboChef, an Authorized Distributor, or its authorized service agent.

Neither TurboChef nor the Authorized Distributor assumes any liability for damage caused by Your failure to provide a proper installation and operating environment (including power and HVAC) or facilities as outlined in the Manual, as well as damage resulting from misuse, abuse, accident, neglect, power failure, or power surges (over or under voltage), regardless of how it occurs.

At its sole discretion, TurboChef may replace defective equipment or components with new, recovered, or rebuilt Equipment of equal or greater capacity, and the Authorized Distributor will warrant such replacements for the remaining warranty period. Replaced defective Equipment or components will become the property of TurboChef.

**Warranty Claims:** Any warranty claim must be made directly in writing either to the Authorized Distributor from whom You purchased the Equipment or to TurboChef at the following address:

TurboChef Technologies, Inc.  
2801 Trade Center Drive  
Carrollton, Texas 75007  
Phone: +1 214.379.6000  
Fax: +1 214.379.6073

The claim must include the Equipment's serial number and be received by TurboChef on or before the last day of the Warranty Period. Upon receipt of Your claim, TurboChef will promptly notify an Authorized Distributor or an authorized service agent to contact You, to verify Your claim and, if necessary, to arrange for an on-site repair visit during normal working hours.

**Consumables and Parts Used with the Equipment:** Neither TurboChef nor the Authorized Distributor assumes any liability for consumables and parts used during normal Equipment operation or for damage or failure caused by non-approved cleaning chemicals, devices, or processes. **Charges for Service Not Covered by Limited Warranty:** If You request and receive repairs, replacements, or services not covered by this Limited Warranty, You will be invoiced and must pay the Authorized Distributor or authorized service agent directly, according to their standard charges and business terms.

**Product Liability:** Neither TurboChef nor the Authorized Distributor assumes any liability for any incidental, special or consequential damages, including but not limited to loss of use, lost revenue or profits, or substitute use suffered by You or any third party, whether arising in contract, tort (including negligence), or otherwise resulting from any breach by TurboChef or the Authorized Distributor of the Limited Warranty provided herein.

**Exclusive Remedy:** This Limited Warranty states the Authorized Distributors and TurboChef's sole and exclusive obligation and liability and your sole and exclusive remedy under this Limited Warranty.

**Third-Party Rights:** The UK Contract (Rights of Third Parties) Act 1999 is excluded from applying to this Limited Warranty and nothing herein confers or purports to confer on any third party any benefit or any right to enforce any term of this Limited Warranty.

**Severability:** If any item or provision contained in this Limited Warranty or any part of them ("an offending provision") is declared to be or becomes unenforceable, invalid or illegal for any reason whatsoever in any jurisdiction, the other terms and provisions of this Limited Warranty shall remain in full force and effect in that jurisdiction as if it had been executed without the offending provision appearing in it and the entire Limited Warranty shall remain in full force and effect in all other jurisdictions.

**Governing Law, Entire Agreement:** This Limited Warranty shall be governed by and construed according to English law. The application of the United Nations Convention on International Sale of Goods to this Limited Warranty is expressly excluded. This Limited Warranty may not be altered, amended, or modified by the Authorized Distributor or its service agent, and no representation, alteration, amendment, or modification by TurboChef shall be valid unless in a signed form from TurboChef.

*For service or information:*  
WITHIN NORTH AMERICA CALL  
Customer Support at 800.90TURBO  
OUTSIDE NORTH AMERICA CALL  
+1 214.379.6000 or Your Authorized Distributor



Country Code: NA/EU

---

<i>Global Operations</i>	<i>TurboChef International</i>	<i>Customer Support</i>
2801 Trade Center Drive	Business & Technology	800.90TURBO
Carrollton, Texas 75007 USA	Centre	+1 214.379.6000
+1 214.379.6000 phone	Bessemer Drive	turbochef.com
+1 214.379.6073 fax	Stevenage	
	Herts SG1 2DX	
	United Kingdom	
	+44 8456021544 phone	
	+44 8456021636 fax	