



Model SG213A



Model #: \_\_\_\_\_

Serial #: \_\_\_\_\_



Intertek



Intertek



MADE IN THE U.S.A.

**Instruction Manual for the Globe Slicer  
Models: S213, SG213, S213A & SG213A**

**For all after sales support, visit [www.globefoodequip.com](http://www.globefoodequip.com)**

- Complete the Warranty Registration
- Find an Authorized Servicer
- View Parts Catalogs

**For additional Technical Support call Globe at 1-866-260-0522.**

**- IMPORTANT SAFETY NOTICE -**

This manual contains important safety instructions that must be strictly followed when using this equipment.

**Maintain and use this manual as a reference for training.**



# Index

ATTENTION OWNERS AND OPERATORS.....	4
KEY COMPONENTS OF THE SLICER .....	5
ADDITIONAL FEATURES .....	6
GLOBE SLICER SAFETY TIPS .....	7
INSTALLATION .....	8-9
OPERATING INSTRUCTIONS.....	10-13
CLEANING & SANITIZING.....	14-17
KNIFE SHARPENING .....	18-19
INSPECTIONS, SIMPLE MAINTENANCE AND REPAIR .....	21-23
SETTINGS MODE.....	25-27
TROUBLESHOOTING GUIDE.....	28



**GLOBE FOOD EQUIPMENT CO.**  
**2153 DRYDEN RD.**  
**DAYTON, OH 45439**  
**Toll Free: 800-347-5423**  
**PHONE: 937-299-5493**  
**E-MAIL: [info@globefoodequip.com](mailto:info@globefoodequip.com)**  
**WEBSITE: [www.globefoodequip.com](http://www.globefoodequip.com)**

# Attention Owners and Operators

Globe's equipment is designed to provide years of safe and productive processing of food products as long as the equipment is used in accordance with the instructions in this manual and is properly maintained. Importantly, unless the operator is adequately trained and supervised, there is a possibility of serious injury. Owners of this equipment bear the responsibility to make certain this equipment is used properly and safely. Strictly follow all of the instructions contained in this manual and the requirements of local, state and federal law.

Owners should not permit anyone to touch this equipment unless they are over 18 years of age, are adequately trained and supervised, and have read and understand this manual. Owners should also ensure that no customers, visitors or other unauthorized personnel come in contact with this equipment. Please remember that Globe cannot anticipate every circumstance or environment in which its equipment will be operated. It is the responsibility of the owner and the operator to remain alert to any hazards posed by the function of this equipment, particularly the sharp knife blade and all moving parts. If you are ever uncertain about a particular task or the proper method of operating this equipment, ask your supervisor.

To prevent illness caused by the spread of food-borne pathogens, it is important to properly clean and sanitize the entire slicer as any surface of the slicer can become contaminated. It is the responsibility of the slicer owner/operator to follow all guidelines, instructions and laws as established by your local and state health departments and the manufacturers of chemical sanitizers.

When cleaning your slicer, pay particular attention to cracks, broken seams and any area that may collect food debris. If your slicer, or any of its parts, is damaged or broken, it may become more difficult to properly clean and sanitize the unit. If your slicer is damaged or needs repair, contact an experienced service individual immediately to ensure the slicer can be properly sanitized. If you have any questions, please contact Globe at 937-299-5493.

This manual offers information to supplement your procedures to improve the sanitization of your machine and contains a Safety Tips section listing a number of precautions to follow to help promote safe use of this equipment. Throughout the manual you will see additional warnings to help alert you to potential hazards.

**Warnings affecting your personal safety are indicated by:**



or



**Warnings related to possible damage to the equipment are indicated by:**



A wall chart with safety instructions is included with this equipment. This wall chart should be posted near the slicer within easy view of the operator. You should make certain that this manual is available for easy reference by any operator. Globe has put several warning labels in the English language on the slicer. French and Spanish labels are also available and can replace the English labels at the owner's discretion. If the warning labels, the wall chart, or this manual are misplaced, damaged or illegible, or if you require additional copies, please contact your nearest representative or Globe directly for these items at no charge.

Please remember this manual, the wall chart and the warning labels do not replace the need to be alert, to properly train and supervise operators, and to use common sense when using this equipment.

# Key Components of the Slicer

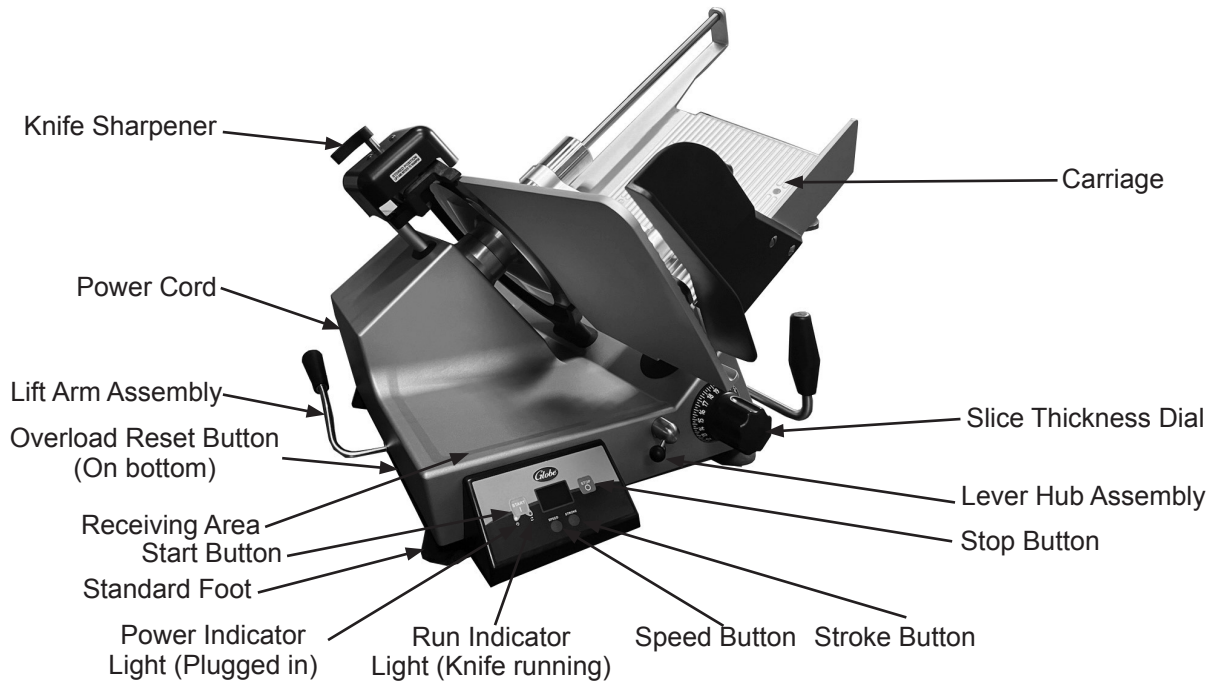

**Model SG213A**

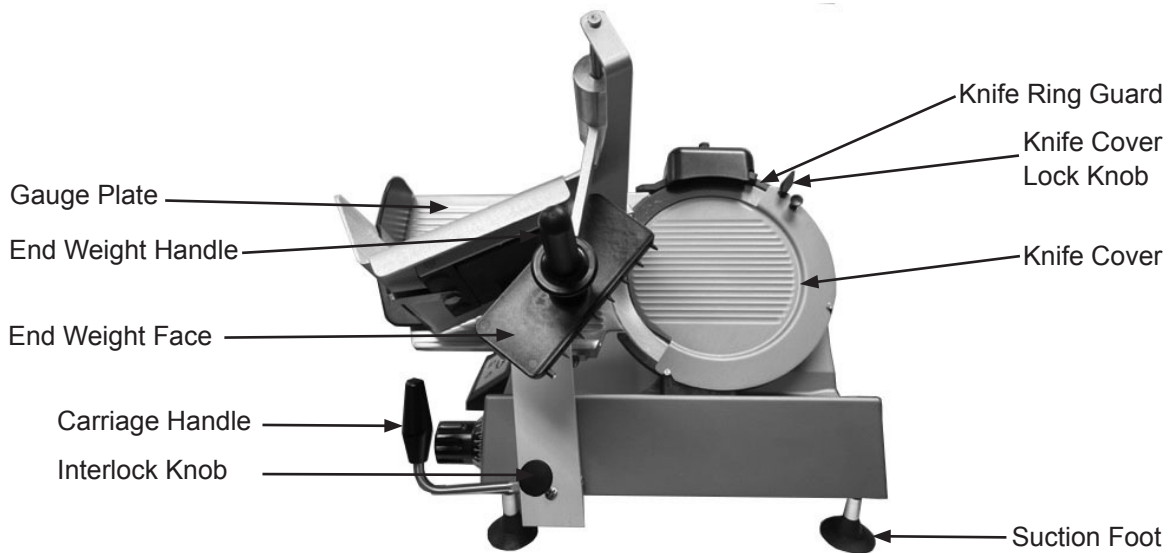

## **Additional Features (Models SG213 & SG213A only)**

1. Four-hour cleaning timer. This timer compliments any HAACP procedures your business has in place, by alerting the users when they are getting near to four hours since making their first slice and stopping the slicer for cleaning when four hours is reached.
2. Motion Timer turns off the slicer after 30 seconds of non-usage. This is adjustable in 5 second increments from 5 to 60 seconds.
3. Home-to-Start feature only allows the slicer to be started when the carriage is in its most forward position, the farthest position from the knife.
4. Close-to-Stop feature, turns the slicer off when the slice thickness dial is closed from an open position.
5. Carriage Removed feature does not allow the slicer to be turned on when the carriage is removed for cleaning. The only way to remove the carriage is to have it in the home position, the slice thickness dial completely closed and the carriage knob is locked. When the carriage is removed, the slice thickness dial cannot be rotated.
6. The carriage will return to the home position when the stop button is depressed (SG213A only).

## Globe Slicer Safety Tips

 **WARNING**



## SHARP KNIFE BLADE

### TO AVOID SERIOUS PERSONAL INJURY:

- **NEVER** touch slicer before reading and completely understanding everything in this instruction manual. You must be at least 18 years old and have had proper training and authorization from your supervisor.
- **ONLY** install the slicer on a level nonflammable nonskid surface located in a clean, well-lit work area away from children and visitors.
- **ALWAYS** ground slicer utilizing proper power source.
- **NEVER TOUCH KNIFE.** Keep hands and arms away from all moving parts, hold only the carriage handle.
- **NEVER OPERATE** slicer without knife cover and knife sharpener securely installed.
- **NEVER HOLD THE FOOD PRODUCT WHILE SLICING.** Hold only the carriage handle to slice.
- **DO NOT CATCH SLICES WITH YOUR HAND.** Let slices drop onto the receiving area.
- **ALWAYS** turn knife motor OFF and turn the slice thickness dial clockwise until it stops after each use.
- **BEFORE CLEANING, SERVICING, OR REMOVING ANY PARTS** always turn knife motor OFF, turn the slice thickness dial clockwise until it stops and unplug power cord.
- **ALWAYS** properly clean and sanitize your slicer. To prevent illness or death caused by the spread of food-borne pathogens, it is important to properly clean and sanitize the entire slicer as any surface of the slicer can become contaminated. It is the responsibility of the slicer owner/operator to follow all guidelines, instructions and laws as established by your local and state health departments and the manufacturers of chemical sanitizers.
- **USE ONLY PROPERLY INSTALLED GLOBE SLICER ACCESSORIES.**

# Installation

## UNPACKING

1. Inspect the package carefully before unpacking. Note any damage on the delivery paperwork and take pictures.
2. Unpack the slicer immediately after receipt. If the machine is found to be damaged, immediately contact us at [help@globefoodequip.com](mailto:help@globefoodequip.com) or call 1-800-347-5423 ext. 253. Please include your name, serial #, item that is damaged, explanation of the damage and photographs if possible. The damage must be reported to Globe within 7 days from the time of shipment. Refer to Globe's Freight Damage policy for more information. <https://globefoodequip.com/support/order-return-policy.html>
3. With the slicer you should receive wall chart, lubricating oil, stiff bristled brush and an instruction manual. Contact Globe or your local supplier if you did not receive all of these items.



## **TO AVOID SERIOUS PERSONAL INJURY PROPERLY INSTALL SLICER IN ADEQUATE WORK AREA**

- **ALWAYS** install equipment in a work area with adequate light and space.
- **ONLY** operate on a solid, level, nonskid surface that is nonflammable.
- **NEVER** operate slicer with a damaged power cord or power plug.
- **NEVER** operate slicer with an extension cord.
- **NEVER** bypass, alter, or modify this equipment in any way from its original condition. Doing so can create hazards and will void warranty.
- **NEVER** operate slicer without the knife cover and knife sharpener securely installed.
- **NEVER** operate slicer without the warning labels attached to slicer (see Key Components, Simple Maintenance and Repair section) and the Globe wall chart posted within view of operator.

## INSTALLATION:

1. Read this manual thoroughly before installation and operation. **DO NOT** proceed with installation and operation if you have any questions or if you do not understand everything in the manual. Contact your local representative or Globe first. ***Make sure to clean and sanitize your entire slicer before use. Refer to this manual for cleaning and sanitizing guidelines.***
2. Select a location for the slicer that has a level, solid, nonskid surface that is nonflammable and is in a well-lit work area that is away from children and visitors.



**USE AT LEAST TWO PEOPLE TO LIFT SLICER BY THE SLICER BASE UP TO OPERATING LOCATION. NEVER ATTEMPT TO LIFT SLICER ALONE.**

3. Remove slicer from the corrugated box.



**NEVER USE SLICER WITHOUT FOUR RUBBER FEET SECURELY INSTALLED ON UNIT.**

4. Make sure rubber feet are firmly tightened.

# Installation



**THIS MACHINE IS PROVIDED WITH A THREE-PRONG GROUNDING PLUG. THE OUTLET TO WHICH THIS PLUG IS CONNECTED MUST BE PROPERLY GROUNDED. IF THE RECEPTACLE IS NOT THE PROPER GROUNDING TYPE, CONTACT AN ELECTRICIAN. DO NOT, UNDER ANY CIRCUMSTANCES, CUT OR REMOVE THE THIRD GROUND PRONG FROM THE POWER CORD OR USE ANY ADAPTER PLUG (Fig. 9-1 and Fig. 9-2).**

5. Inspect slicer to make sure all parts have been provided.
6. Make sure knife cover and knife sharpener are in place.
7. Make sure warning labels are properly positioned and legible and the instruction manual is available near slicer.
8. Complete warranty registration online at [www.globefoodequip.com/support/warranty-registration-form](http://www.globefoodequip.com/support/warranty-registration-form).
9. Post the provided wall chart in a visible area near slicer. Refer to the wall chart and the Owner's Manual for proper cleaning, sanitizing and inspection of the slicer.
10. Refer to the procedures outlined in Cleaning & Sanitizing section to clean the slicer before use.
11. Contact your local representative, or Globe directly, if you have questions or problems with the installation or operation of the slicer.



Figure 9-1 Correct



Figure 9-2 Incorrect

# Operating Instructions

## **⚠️ WARNING**



## **SHARP KNIFE BLADE**

### **TO AVOID SERIOUS PERSONAL INJURY:**

- **NEVER** touch slicer before reading and completely understanding everything in this instruction manual. You must be at least 18 years old and have had proper training and authorization from your supervisor.
- **ONLY** install slicer on a level nonskid, nonflammable surface located in a clean, well-lit work area away from children and visitors.
- **ALWAYS** ground slicer utilizing proper power source.
- **NEVER TOUCH KNIFE.** Keep hands and arms away from all moving parts, hold only the carriage handle.
- **NEVER OPERATE** slicer without knife cover and knife sharpener securely installed.
- **NEVER HOLD FOOD PRODUCT WHILE SLICING.** Hold only the carriage handle to slice.
- **DO NOT CATCH SLICES WITH YOUR HAND.** Let slices drop onto the receiving area.
- **ALWAYS** turn knife motor OFF and turn slice thickness dial clockwise until it stops after each use.
- **BEFORE CLEANING, SERVICING, OR REMOVING ANY PARTS** always turn knife motor OFF, turn slice thickness dial clockwise until it stops and unplug power cord.

### **MANUAL SLICER OPERATION (S213, SG213, S213A & SG213A)**

**Note:** The slicer is equipped with a four hour cleaning timer. After the four hour cleaning timer expires, all slicer functions will stop and the operator must follow the cleaning steps provided in order to reset the four hour cleaning timer. To disable this feature, refer to the Settings Mode Section of this manual (Models SG213 & SG213A only).

1. Plug in power cord (Models S213, SG213, S213A and SG213A).

**Note:** When the slicer is plugged in the white POWER indicator light will illuminate.

**Note:** When carriage is not returned to operating position (to the left), the knife motor will not start and display will show "ATTENTION Carriage Removed Install Carriage to Resume" (Models S213A, SG213 & SG213A only).

**Note:** If carriage lock lever is not secure, slicing performance will be poor and excessive noise could occur.

2. Make sure all knobs are tightened before using slicer.

**Note:** Slice only boneless, unfrozen product with the slicer.

3. With knife motor turned OFF, pull carriage completely towards you to unload and load food product. Use end weight to hold food product in place.
4. Rotate slice thickness dial counterclockwise to the desired setting.
5. Push START button to turn on knife motor.

**Note:** The green RUN indicator light will illuminate.

**Note:** Circle on display will spin (Models S213A, SG213 & SG213A only).

**Note:** If Home-to-Start is enabled and the carriage is not in the home position, the display will show "ATTENTION Return Carriage to Operator to Start" (Models SG213 & SG213A only).

# Operating Instructions



**DO NOT hold the food product with your hand. Never put your hand on or around carriage when slicer is under power. The carriage handle is the only part of the slicer you should touch while slicing.**

6. Use carriage handle to manually push carriage back and forth. The carriage handle is the only part of slicer you should touch while slicing. Do not catch slices with your hand. Let slices drop onto receiving area.

**Note: The slicer is equipped with a programmable auto-off timer. After 30 seconds (factory default) of no carriage movement, the knife motor will shut off (Models SG213 & SG213A only).**



**If a product needs to be adjusted during slicing, ALWAYS pull the carriage all the way towards you. Turn off knife motor, and close gauge plate prior to adjusting the product and the end weight.**

7. After the last slice stroke, pull carriage all the way towards you. Push the STOP button to turn knife motor OFF.

**Note: The green RUN indicator light will go out.**

**Note: Circle on display will stop spinning (Models S213A, SG213 & SG213A only).**

8. Turn slice thickness dial clockwise until it stops to close gauge plate. Unload and load food product.

**Note: The slicer is also equipped with a Close to Stop feature. When the slice thickness dial is closed, the knife motor will stop (Models SG213 & SG213A only).**

9. Unplug slicer after each days use or before cleaning and servicing.

## **FOUR HOUR CLEANING TIMER (Models SG213 and SG213A only)**

**Note: This feature is enabled at the factory. The four hour cleaning timer will start when the slicer detects the first slice. To disable this feature, refer to the Settings Mode Section of this manual.**

**Note: When 30 minutes are remaining on the four hour cleaning timer, the display will show "ATTENTION: 30 minutes to clean slicer." Slicer will operate as normal when the alert is displayed.**

1. To clear alert on display, press and hold the STOP button for three seconds.

**Note: When 15 minutes are remaining on the four hour cleaning timer, the display will show "ATTENTION: 15 minutes to clean slicer." Slicer will operate as normal when the alert is displayed.**

2. To clear alert on display, press and hold the STOP button for three seconds.

**Note: After the four hour cleaning timer expires, the slicer will no longer operate and display will show "ATTENTION: Unplug and clean slicer to resume."**

3. Refer to Cleaning and Sanitizing.

# Operating Instructions

## AUTOMATIC SLICER OPERATION (Models S213A and SG213A)

**Note:** Model SG213A. The slicer is equipped with a four hour cleaning timer. After the four hour cleaning timer expires, all slicer functions will stop and the operator must follow the cleaning steps provided in order to reset the four hour cleaning timer. To disable this feature, refer to the Settings Mode Section of this manual.

1. Make sure all knobs are tightened before using slicer.
2. With knife motor turned OFF, pull carriage completely towards you and place food product onto carriage. Slice only boneless, unfrozen product with the slicer. Use end weight to hold food product in place.
3. To make carriage move automatically, move the auto engage lever into "AUTOMATIC" position (Fig. 12-1).

**Note:** During slicing, if the STOP button is pushed and the auto engage lever is in the "AUTOMATIC" position, the carriage will return to the home position and the slicer will remain in "AUTOMATIC" mode. To continue slicing in "Automatic" mode, push the START button. To return to "MANUAL" mode, press STOP button and move auto engage lever to "MANUAL" position (Model SG213A only).

4. Rotate slice thickness dial counterclockwise to the desired setting.



Figure 12-1



**BE ALERT.** The next step will cause carriage to move automatically on start up.

5. Push START button to turn on knife motor.

**Note:** The green RUN indicator light will illuminate.

**Note:** The circle on display will spin (Models S213A& SG213A only).

**Note:** If Home-to-Start is enabled and the carriage is not in the home position, the display will show "ATTENTION Return Carriage to Operator to Start" (Model SG213A only).



SPEED STROKE

Figure 12-2

6. To adjust the speed of the carriage, select the SPEED button (Fig. 12-2).

**Note:** When the auto engage lever is in the AUTOMATIC position, up to four speed settings are available with the SPEED button (Model SG213A only).

**Note:** When the auto engage lever is in the AUTOMATIC position, up to two speed settings are available with the SPEED button (Model S213A only).

7. To adjust the stroke of the carriage, select the STROKE button.

**Note:** When the auto engage lever is in the AUTOMATIC position, up to three stroke lengths are available with the STROKE button (Model SG213A only).

**Note:** When the auto engage lever is in the AUTOMATIC position, up to two stroke lengths are available with the STROKE button (Model S213A).

8. To stop the automatic movement of the carriage, press STOP button and move the auto engage lever to the "Manual" position (Fig. 12-3).

9. To stop knife motor, press STOP button. Pressing the STOP button while the auto engage lever is in the automatic position will return the carriage to the home position and shut the knife motor off (Model SG213A only).

**Note:** The green RUN indicator light will go out.

**Note:** The circle on display will stop spinning (Models S213A & SG213A).

**Note:** The slicer is also equipped with a Close to Stop feature. When the slice thickness dial is closed, the knife motor will stop (Model SG213A).

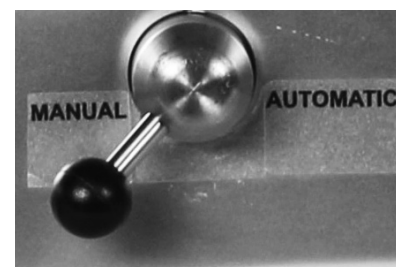

Figure 12-3

# Operating Instructions

## FOUR HOUR CLEANING TIMER (Model SG213A only)

**Note:** This feature is enabled at the factory. The four hour cleaning timer will start when the slicer detects the first slice. To disable this feature, refer to the Settings Mode Section of this manual.

**Note:** When 30 minutes are remaining on the four hour cleaning timer, the display will show "ATTENTION: 30 minutes to clean slicer." Slicer will operate as normal when the alert is displayed.

1. To clear alert on display, press and hold the STOP button for three seconds.

**Note:** When 15 minutes are remaining on the four hour cleaning timer, the display will show "ATTENTION: 15 minutes to clean slicer." Slicer will operate as normal when the alert is displayed.

2. To clear alert on display, press and hold the STOP button for three seconds.

**Note:** After the four hour cleaning timer expires, the slicer will no longer operate and display will show "ATTENTION: Unplug and clean slicer to resume."

3. Refer to Cleaning and Sanitizing.

4. Plug in power cord (Models S213A and SG213A).

**Note:** When the slicer is plugged in the white POWER indicator light will illuminate.

**Note:** When carriage is not returned to operating position (to the left), the knife motor will not start and display will show "ATTENTION Carriage Removed Install Carriage to Resume" (Models S213A & SG213A only).

**Note:** If carriage lock lever is not secure, slicing performance will be poor and excessive noise could occur.

# Cleaning & Sanitizing

## ⚠ WARNING



## SHARP KNIFE BLADE

TO AVOID SERIOUS PERSONAL INJURY TO THE SLICER OPERATOR AND CUSTOMERS:

- **NEVER** touch slicer before reading and completely understanding everything in this instruction manual. You must be at least 18 years old and have had proper training and authorization from your supervisor.
- **BEFORE CLEANING, SERVICING OR REMOVING ANY PARTS** always turn knife motor OFF, turn slice thickness dial clockwise until it stops and unplug power cord.
- **NEVER** attempt to clean slicer with knife running.
- **NEVER** attempt to remove knife ring guard from slicer. The knife ring guard must remain on slicer for proper operation, sharpening and cleaning.

## ⚠ WARNING

To prevent illness or death caused by the spread of food-borne pathogens, it is important to properly clean and sanitize the entire slicer as any surface of the slicer can become contaminated. It is the responsibility of the slicer owner/operator to follow all guidelines, instructions and laws as established by your local and state health departments and the manufacturers of chemical sanitizers.



Once your slicer makes contact with food product, the entire slicer, including removable parts, must be thoroughly **cleaned and sanitized**. This process is to be repeated at least every 4 hours using these procedures and information; and must comply with additional laws from your state and local health departments.



As with all food contact surfaces, it is extremely important to properly **sanitize** the entire slicer and to **closely follow the instructions on your quaternary sanitizer container to make sure proper sanitation is achieved to kill potentially harmful bacteria.**

**Note:** It may be desirable to wear cut proof safety gloves during the cleaning operation.

**IMPORTANT:** If a chemical sanitizer other than chlorine, iodine or quaternary ammonium is used, it must be applied in accordance with the EPA-registered label use instructions. Excessive amounts of sanitizer and use of products not formulated for stainless steel or aluminum may VOID your warranty.

Sanitizer concentration must comply with section 4-501.114, Manual and Mechanical Warewashing Equipment, Chemical Sanitization - Temperature, pH, Concentration, and Hardness of the FDA Food Code.

For more information on proper kitchen and equipment sanitation, visit [www.servsafe.com](http://www.servsafe.com) provided by the National Restaurant Association (NRA).

## ⚠ CAUTION

- **DO NOT** hose down, pressure wash or pour water on slicer.
- **NEVER** use a scrubber pad, steel wool or abrasive material to clean slicer.
- **ALWAYS** turn slicer OFF and unplug power cord BEFORE cleaning.
- It is extremely important to follow the instructions on the sanitizer container to make sure proper sanitation is achieved. **Allow the parts to air dry before placing them back on slicer!**

**DO NOT** use bleach, products containing sodium hypochlorite or other caustic/strong detergents on slicer base or removable parts. These products will discolor and destroy the parts.

Slicer components are easily disassembled without the use of special tools. It is recommended to wear cut proof safety gloves during the cleaning operation.

# Cleaning & Sanitizing

## DISASSEMBLY & CLEANING

**Note:** The slicer is equipped with a four hour cleaning timer. After the four hour cleaning timer expires, all slicer functions will stop and the operator must follow the cleaning steps provided in order to reset the four hour cleaning timer. To disable this feature, refer to the Settings Mode Section of this manual (Models SG213 and SG213A).

1. Push STOP button to turn off knife motor.
2. Turn slice thickness dial clockwise past zero (0) until it stops so gauge plate covers knife edge.
3. Unplug power cord.

**Note:** When slicer is unplugged the white POWER indicator light will go out.

4. Pull carriage toward you (home position).
5. Unlock the carriage lock lever that fastens the carriage to the carriage arm (Fig. 15-1).
6. Push in and turn the interlock knob counterclockwise (1/4 turn) (Models SG213 & SG213A) to unlock the carriage tray from the carriage arm (Fig. 15-2).
7. Remove the carriage tray from carriage arm (Fig. 15-3).
8. Turn the removable end weight face counterclockwise to remove the end weight face from the camlock shaft and handle (Fig. 15-4).

 **BE ALERT. The next step will expose knife.**

9. Remove knife cover. Turn knife cover lock knob counterclockwise. Hold the knife cover lock knob and pull knife cover forward to remove knife cover from top pin (Fig. 15-5).
10. Hold the knife cover lock knob. Carefully tilt knife cover and pull knife cover up and to the right to remove the knife cover from bottom pins.
11. Remove knife sharpener. Pull knife sharpener up and away to remove from slicer (Fig. 15-6).

 **BE ALERT.** Slicer knife edge is exposed. Always be aware of the placement of your hands/fingers in relation to knife.

Place all removable parts in a three compartment sink with warm water and a mild detergent solution; soak, clean, and thoroughly scrub all surfaces using a solution of mild detergent and warm water. Removable parts include: removable end weight face, carriage tray, knife cover and knife sharpener.



Figure 15-1



Figure 15-2

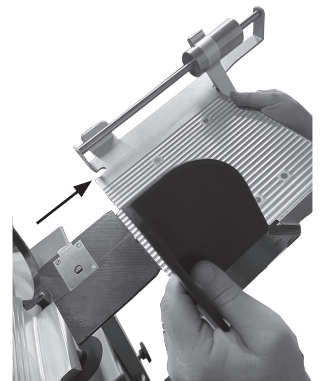

Figure 15-3



Figure 15-4



Figure 15-5



Figure 15-6

# Cleaning & Sanitizing

Rinse removable parts with fresh, clean water. Following the instructions on your quaternary sanitizer label, soak the removable end weight face, carriage tray, knife cover and knife sharpener in a proper solution of quaternary sanitizer for a minimum of two minutes. Allow these parts to air dry.

**An important step to kill bacteria is to allow the parts to air dry before reassembly!**

**BE ALERT.** The slicer knife is fully exposed. Always be aware of the placement of your hands/fingers in relationship to the knife.

12. Next, clean knife ring guard. Soak a clean cloth in a mild detergent and warm water solution. Ring out excess water from cloth. **Carefully** insert the cloth between knife and knife ring guard (Fig. 16-1). While holding the cloth between knife and knife ring guard, work it along the entire inside surface of ring guard. Repeat this procedure as necessary. Spray sanitizer on all surfaces and let air dry.

13. The knife must also be cleaned and sanitized. **Carefully** wash and rinse the top and bottom of knife by wiping from the **center of knife outward** (Fig. 16-2). Spray both sides of knife with a non-bleach, non-chlorine sanitizer following the instructions on your quaternary sanitizer container to make sure proper sanitation is achieved. **Allow slicer parts to air dry.**

**An important step to kill bacteria is to allow the parts to air dry before reassembly!**

**CAUTION** After cleaning and sanitizing the knife, the rest of the entire slicer must be fully cleaned, sanitized and left to air dry before reattaching slicer parts and using the slicer.

14. Soak a clean cloth in a mild detergent and warm water solution. Wring out excess water from cloth. With the gauge plate completely closed, wipe gauge plate off by starting at knife and pulling towards you. Never wipe gauge plate towards knife. Spray or wipe a sanitizer on the gauge plate and allow it to air dry.

15. With a clean cloth soaked in mild detergent, wipe down all remaining surfaces of slicer to remove food, debris and grease/oil. Use a nylon brush to scrub difficult areas. Use a clean, wet cloth to rinse the entire slicer. Finish by spraying sanitizer on all surfaces and then let air dry.

## **REINSTALL REMOVABLE PARTS**

After cleaning, sanitizing, and allowing the parts to air dry, they must be reinstalled.

**BE ALERT.** Slicer knife is exposed. Always be aware of the placement of your hands/fingers in relationship to knife.

1. Reinstall the knife cover. Align the knife cover with the pins located at the bottom and the top of the knife guard. The locator pin at the top of the knife ring guard must be set through the knife cover and pressed into place. Once the knife cover hole is seated over the pin, turn the knife cover lock knob clockwise to secure knife cover (Fig. 16-3).
2. Reinstall knife sharpener. Put knife sharpener at the top of slicer with knife sharpener handle pointing down (Fig. 16-4).

**NEVER** operate slicer without knife sharpener installed. Make sure it is in place and fully seated on top of slicer before operating.



Figure 16-1



Figure 16-2

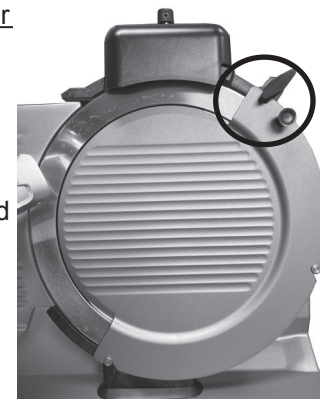

Figure 16-3



Figure 16-4

# Cleaning & Sanitizing

3. Install the cleaned and sanitized carriage tray on the carriage arm (Fig. 17-1).
4. Lock the carriage lock lever to secure carriage tray to the carriage arm (Fig. 17-2).
5. Push in and turn the interlock knob clockwise (1/4 turn) (Models SG213 & SG213A) to lock the carriage tray on the carriage arm (Fig. 17-3).
6. Reinstall removable end weight face on the camlock shaft and handle.
7. Turn removable end weight face clockwise to secure to camlock shaft and handle (Fig 17-4). Refer to Inspection, Simple Maintenance, and Repair section for instructions on how to lubricate the end weight slide rod.
8. Plug in power cord.

**Note:** When slicer is plugged in, the white **POWER** indicator light will illuminate.

**Note:** When carriage is not returned to operating position (to the left), the knife motor will not start and display will show "ATTENTION Carriage Removed Install Carriage to Resume" (Models SG213, S213A and SG213A).

**Note:** If carriage lock lever is not secure, slicing performance will be poor and excessive noise could occur.

## **FOUR HOUR CLEANING TIMER (Models SG213 & SG213A only)**

**Note:** This feature is enabled at the factory. The four hour cleaning timer will start when the slicer detects the first slice. To disable this feature, refer to the Settings Mode Section of this manual.

**Note:** When 30 minutes are remaining on the four hour cleaning timer, the display will show "ATTENTION: 30 minutes to clean slicer." Slicer will operate as normal when the alert is displayed.

1. To clear alert on display, press and hold the STOP button for three seconds.

**Note:** When 15 minutes are remaining on the four hour cleaning timer, the display will show "ATTENTION: 15 minutes to clean slicer." Slicer will operate as normal when the alert is displayed.

2. To clear alert on display, press and hold the STOP button for three seconds.

**Note:** After the four hour cleaning timer expires, the slicer will no longer operate and display will show "ATTENTION: Unplug and clean slicer to resume."

3. Refer to Cleaning and Sanitizing.

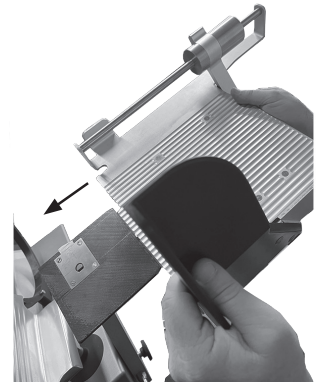

Figure 17-1

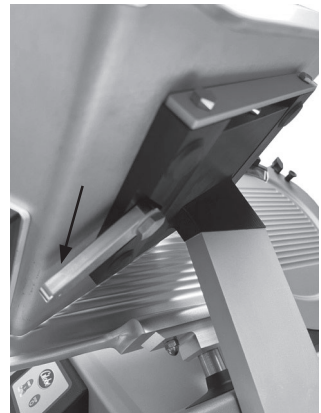

Figure 17-2



Figure 17-3



Figure 17-4

# Knife Sharpening

**WARNING**



## SHARP KNIFE BLADE

### TO AVOID SERIOUS PERSONAL INJURY:

- **NEVER** touch slicer before reading and completely understanding everything in this instruction manual. You must be at least 18 years old and have had proper training and authorization from your supervisor.
- **NEVER** touch rotating knife.
- **ALWAYS** keep hands clear of all moving parts.
- **ALWAYS** turn slicer off, turn slice thickness dial clockwise until it stops and pull carriage completely towards you before sharpening.
- **NEVER** sharpen knife unless knife cover is installed.

### WHEN AND HOW OFTEN TO SHARPEN KNIFE

1. Symptoms of a dull knife are excess waste (or "tail") on the unsliced portion remaining in carriage.
2. The knife needs to be sharpened periodically to provide consistent slices and maximum food product yield. Sharpening knife lightly every few days is more effective than heavy sharpening at less frequent intervals.

### PREPARING TO SHARPEN

1. Unplug the slicer and turn slice thickness dial clockwise until it stops so gauge plate covers knife's edge.
2. Clean and dry both sides of knife before sharpening. Refer to Cleaning & Sanitizing section.



**BE ALERT. The next step will expose knife.**

3. Slide knife sharpener up its mounting post and rotate it 180 degrees (Fig. 18-1).
4. Lower knife sharpener with handle pointing up (Fig. 18-2).
5. Push down knife sharpener until knife sharpener clicks into position.



Figure 18-1  
Stored Position



Figure 18-2  
Sharpening Position

# Knife Sharpening

## SHARPENING THE KNIFE

**Note:** Sharpening and honing stones will perform correctly **ONLY** when free from dirt, grease and built-up food residue. Use the wire brush included with your slicer to periodically clean the stones **BEFORE** sharpening the knife blade.

1. Plug in power cord.

**Note:** The white **POWER** indicator light will illuminate.

2. Push the **START** button to turn on knife motor.

**Note:** The green **RUN** indicator light will illuminate.

3. Pull knife sharpener handle toward the front so sharpening stone and honing plate make contact with knife (Fig. 19-1). Maintain pressure on the knife sharpener handle for 3-5 seconds.

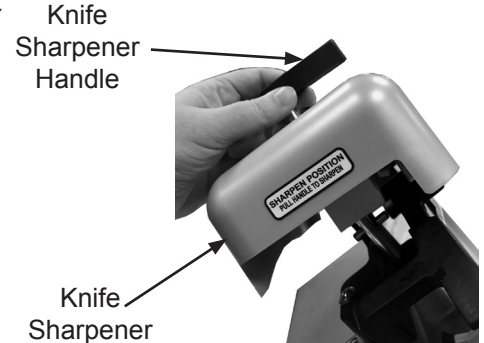

Figure 19-1  
Sharpening Position



**TURN KNIFE MOTOR OFF** before inspecting.

## AFTER SHARPENING

1. Push the **STOP** button to turn knife motor off.

**Note:** The green **RUN** indicator light will go out.

2. Unplug power cord.

**Note:** The white **POWER** indicator light will go out.

3. Lift knife sharpener up and away to remove for cleaning.
4. Clean and sanitize the entire slicer. Refer to Cleaning & Sanitizing section of this manual.
5. Plug in power cord.

**Note:** When slicer is plugged in, the white **POWER** indicator light will illuminate.



Figure 19-2  
Stored Position



**NEVER** operate slicer without knife sharpener installed. Make sure it is in place and secure to top of slicer before operating.

1. Install knife sharpener on slicer in its stored position (Fig. 19-2).

**Note:** When knife sharpener is in stored position, label should display **“STORED POSITION LIFT AND ROTATE TO SHARPEN.”**



# Inspections, Simple Maintenance, and Repair

**WARNING**



## SHARP KNIFE BLADE TO AVOID SERIOUS PERSONAL INJURY:

- **NEVER** touch slicer before reading and completely understanding everything in this instruction manual. You must be at least 18 years old and have had proper training and authorization from your supervisor.
- **BEFORE CLEANING, SERVICING, OR REMOVING ANY PARTS** always turn OFF and unplug slicer and turn slice thickness dial clockwise past zero (0) until it stops.
- **NEVER TOUCH KNIFE.** Keep hands and arms away from all moving parts.
- **DO NOT** tamper with, bypass or remove any safety devices, guards, START/STOP button or touch pad controls.
- **AFTER EACH USE, ALWAYS** turn slicer OFF and turn the slice thickness dial clockwise past zero (0) until it stops.
- **USE ONLY PROPERLY INSTALLED GLOBE PARTS AND ACCESSORIES.**

### INSPECTING THE SLICER

INSPECT THE SLICER FOR DAMAGED OR BROKEN PARTS INCLUDING GASKETS & SEALS. A thorough visual inspection should be made of the entire slicer and its parts. Globe urges the owner/operator to inspect all components daily and for an authorized service agent to inspect the entire slicer at least every 6 months, including all parts that are detachable for cleaning and sanitizing. This inspection should include looking for damaged parts, broken seals or gaskets, and areas that may be more difficult to clean and sanitize.

**WARNING**

IF A SEAL OR GASKET IS FOUND TO NOT PROPERLY SEAL, IS DAMAGED OR IS MISSING, THE SLICER MUST BE REMOVED FROM SERVICE UNTIL IT IS REPAIRED BY AN AUTHORIZED SERVICER.

### SLICER INSPECTION

Slicer Seals and Gaskets Identified

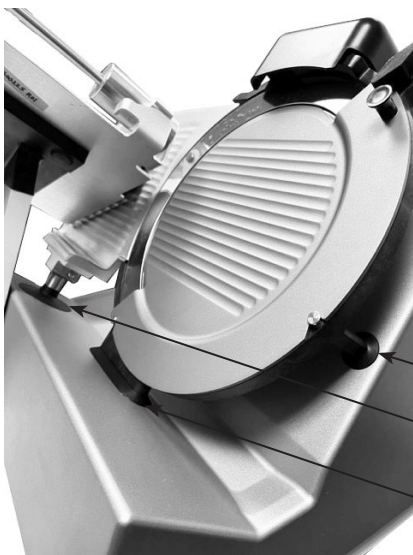

I  
N  
S  
P  
E  
C  
T

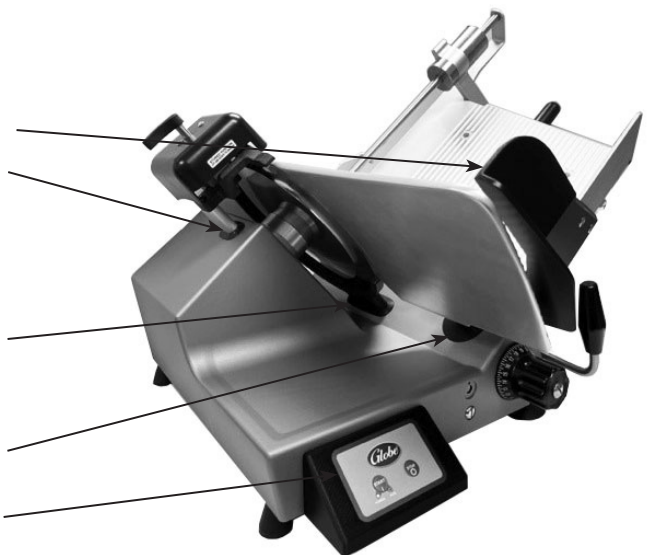

# Inspections, Simple Maintenance, and Repair

## LUBRICATION

Various slicer parts need to be lubricated periodically using Globe oil (Fig. 22-1). Globe oil is a light, tasteless, odorless mineral oil that will not contaminate or impart odors or taste to sliced food products.

**CAUTION** DO NOT USE VEGETABLE OIL TO LUBRICATE SLICER. VEGETABLE OIL WILL DAMAGE THE SLICER!

### Sharpener and Shafts

In addition to cleaning the sharpener stones, it is suggested that the sharpener shafts be lubricated with Globe oil on a regular basis.

**BE ALERT.** The next step will expose knife.

1. Pull knife sharpener up by its handle to remove it from slicer (Fig. 22-2).
2. Apply several drops of Globe oil to the exposed shaft of both stones (Fig. 22-3).
3. Push the sharpener handle several times to distribute the oil onto shafts.
4. Replace sharpener to its stored position on the slicer.
5. Wipe off any excess oil that drips onto slicer.

**Note:** The knife sharpener and stones can be cleaned with warm water and a brush. Allow to air dry. If the knife sharpener or stones are cleaned, it is very important that all sharpener shafts are lubricated with Globe oil afterwards!

### End Weight Shaft

The end weight shaft should be lubricated with a few drops of Globe oil, every week or when excessive drag is felt.

1. Apply a few drops of Globe oil to end weight shaft (Fig. 22-4).
2. Slide end weight up and down to distribute oil.
3. Wipe off any excess oil that drips onto slicer.



Figure 22-1

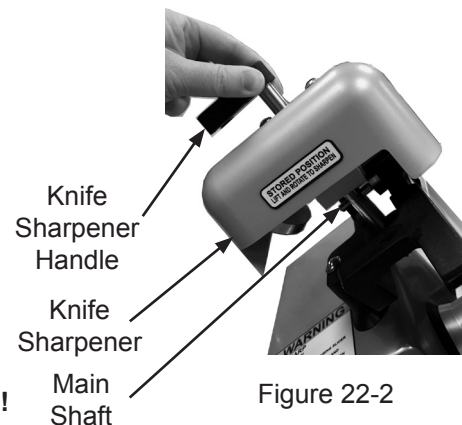

Figure 22-2

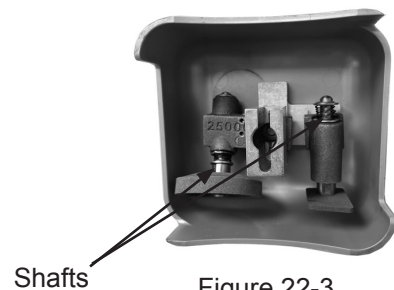

Figure 22-3

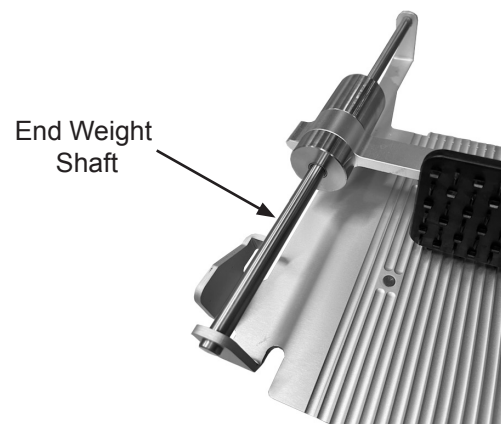

Figure 22-4

# Inspections, Simple Maintenance, and Repair

## Transport Shaft

The transport shaft reservoir should be lubricated with Globe oil, once a year or when excessive drag is felt.

1. Unplug slicer before servicing.

### **WARNING**

**KEEP HANDS AND FINGERS CLEAR OF THE TRANSPORT SHAFT AT ALL TIMES. THE TRANSPORT SHAFT WILL MOVE WHEN THE SLICER IS PLACED ON END.**

### **CAUTION**

**USE TWO PEOPLE TO TILT THE SLICER ON END IN ORDER TO GAIN ACCESS TO THE TRANSPORT RESERVOIR. DAMAGE TO SLICER CAN OCCUR.**

2. Use two people to place slicer on end in order to gain access to the transport shaft reservoir on the bottom of the slicer.
3. Remove the hex head screw from the transport shaft reservoir (Fig. 23-1).
4. Add Globe oil to a 12 ml (cc) syringe (Fig. 23-2).

**Note: Fill the transport shaft reservoir with Globe oil until the transport shaft reservoir starts to overflow with the Globe oil.**

5. Use the syringe to add Globe oil to the transport shaft reservoir (Fig. 23-3).
6. Install the hex head screw on the transport shaft reservoir.
7. Use two people to lower the slicer back to operating position.
8. Use the carriage handle to push the carriage tray back and forth several times to distribute the oil on the transport shaft.



Figure 23-1



Figure 23-2



Figure 23-3



# Settings Mode (Models SG213, S213A & SG213A only)

Settings Mode is made up of four sub menu displays: Options, Counters, Service and Information. Refer to the table below for the options and actions of each available menu display.

## Entering Settings Mode

Two options are available for entering the settings mode.

Option One:

1. Unplug the slicer.
2. While holding down the STOP button, plug in the slicer. During start up the display will show "Entering Settings Mode."

**Note: Once Settings Mode has been entered, use the STOP button to navigate through selections and the START button to select the option.**

MENUS	OPTIONS	ACTION
<b>Options</b>		
<b>Language Setup (Models S213A and SG213A only)</b>	"ATTENTION" screens will alternate between Language 1 and Language 2 displaying each for 5 seconds.	No action required.
Language 1	Displays primary language.	No action required.
English	Displays language options English, French and Spanish.	Select START button to select language. Press STOP button once language selection has been made. Select START button to Save and Exit.
French	Displays language options English, French and Spanish.	Select START button to select language. Press STOP button once language selection has been made. Select START button to Save and Exit.
Spanish	Displays language options English, French and Spanish.	Select START button to select language. Press STOP button once language selection has been made. Select START button to Save and Exit.
Language 2	Displays secondary language.	No action required.
English	Displays language options English, French and Spanish.	Select START button to select language. Press STOP button once language selection has been made. Select START button to Save and Exit.
French	Displays language options English, French and Spanish.	Select START button to select language. Press STOP button once language selection has been made. Select START button to Save and Exit.
Spanish	Displays language options English, French and Spanish.	Select START button to select language. Press STOP button once language selection has been made. Select START button to Save and Exit.

## Settings Mode (Models SG213, S213A & SG213A only)

MENUS	OPTIONS	ACTION
Cleaning Timer (Models SG213 and SG213A only)	Enable or Disable Factory Default is set to Enable	When enabled the 4 hour cleaning timer will begin with the first detected slice.
Home-to-Start (Models SG213 and SG213A only)	Enable or Disable Factory Default is set to Enable	When enabled and the carriage is not in the home position, the knife motor will not start. ATTENTION Return Carriage to Operator to start will display.
Close to Stop (Models SG213 and SG213A only)	Enable or Disable Factory Default is set to Enable	When enabled and the slice thickness dial is closed, the knife motor will stop.
Motion Timer (Models SG213 and SG213A only)	Enable or Disable OFF, 5-60 seconds in 5 second increments Factory Default is set to 30 seconds	When enabled and the carriage is not in use for 30 seconds, the knife motor will stop. Settings can be adjusted from 5 seconds up to 60 second increments.
Backlight Timer (Models SG213 and SG213A only)	Enable or Disable OFF, 10-60 seconds in 10 seconds increments Factory Default is set at 30 seconds	When enabled and the slicer is not in use for 30 seconds, the backlight display will go off. Settings can be adjusted from 10 seconds up to 60 second increments.
<b>Counters</b>		
Total Slices	Counts the number of strokes made with the knife running.	No action required.
Manual Slices	Displays the total number of slices in manual mode.	No action required.
<b>Speed 1</b>		
Stroke		
1 (Models S213A and SG213A only)	Displays the total number of slices in speed 1 stroke 1.	No action required.
2 (Model SG213A only)	Displays the total number of slices in speed 1 stroke 2.	No action required.
3 (Models S213A and SG213A only)	Displays the total number of slices in speed 1 stroke 3.	No action required.
<b>Speed 2 (Model SG213A only)</b>		
Stroke		
1	Displays the total number of slices in speed 2 stroke 1.	No action required.
2	Displays the total number of slices in speed 2 stroke 2.	No action required.
3	Displays the total number of slices in speed 2 stroke 3.	No action required.

## Settings Mode (Models SG213, S213A & SG213A only)

MENUS	OPTIONS	ACTION
<b>Speed 3 (Model SG213A only)</b>		
Stroke		
1	Displays the total number of slices in speed 3 stroke 1.	No action required.
2	Displays the total number of slices in speed 3 stroke 2.	No action required.
3	Displays the total number of slices in speed 3 stroke 3.	No action required.
<b>Speed 4</b>		
Stroke		
1 (Models S213A and SG213A only)	Displays the total number of slices in speed 4 stroke 1.	No action required.
2 (Model SG213A only)	Displays the total number of slices in speed 4 stroke 2.	No action required.
3 (Models S213A and SG213A only)	Displays the total number of slices in speed 4 stroke 3.	No action required.
<b>Service</b>		
System Inputs	Used to determine if the machine sensors are functioning properly. Select a button or sensor to test machine.	Example: When the START button is selected and the safety sensor is working properly, "Start" on the display will illuminate.
<b>Operations</b>		
In Service (HRS)	Displays the total amount of time the slicer has been plugged in.	No action required.
Knife Motor	Displays the total amount of time in hours that the knife motor has ran.	No action required.
Carriage Motor	Displays the total amount of time in hours that the slicer has been used in auto mode.	No action required.
Power Cycles	Displays the total amount of times the slicer has been connected to power.	No action required.
Carriage Stalls (Models S213A and SG213A)	Displays the total amount of times the carriage has stalled in auto mode	No action required.
<b>Reset</b>		
Knife Motor	Displays the Reset Knife Timer.	Press STOP to verify reset operation.
Carriage Motor (Model SG213A only)	Displays the Auto Timer Motor.	Press STOP to verify reset operation.
<b>Information</b>		
<b>Communication</b>	For Diagnostics and Debug	Qualified Service Technician Only
<b>About</b>	Displays the Model Number	No action required.
	Displays Rated Input Voltage	No action required.
	Displays Software version	No action required.

# Troubleshooting Guide

PROBLEM	CAUSE	SOLUTION
Knife motor will not start	Slicer not plugged in	Plug in slicer
	Overload reset button tripped	Press the reset button located underneath the slicer
	Carriage not in home position	Pull carriage to operator to start
	Carriage tray not installed	Install carriage tray
	Four hour cleaning timer is enabled	Refer to Cleaning section
Knife motor stopped running (Models SG213 & SG213A only)	Motion time-out is enabled and no carriage movement has been detected in the time specified in the maintenance mode menu	Adjust the amount of seconds until time-out in the maintenance mode menu
	Slice thickness dial closed	Adjust slice thickness dial and select START
Ragged cuts-poor yield	Dull knife	Sharpen knife. Make sure knife and stones are clean
	Chipped knife	Sharpen or have new knife installed
	Knife-gauge plate gap too wide	Call for service to adjust gauge plate
	Knife too small	Have new knife installed
Excessive drag is felt on end weight shaft	End weight shaft needs lubrication	Refer to Inspection, Simple Maintenance and Repair Section
Excessive drag is felt during slicing	Transport shaft needs lubrication	Refer to Inspection, Simple Maintenance and Repair Section
Part scraping knife	Knife cover	Lock knife cover lock knob
	Carriage	Adjust carriage tray.
	Gauge plate	Call for service to adjust gauge plate
Hard to sharpen	Stones dirty, wet or clogged with grease	Clean stones with warm water and a brush. Allow stones to air dry. Lubricate shafts with Globe oil afterwards
	Knife dirty	Clean top and bottom of knife
	Worn stones	Have stones replaced
	Stones not properly aligned	Have sharpener adjusted

If problems persist and the assigned solution does not remedy the issue, please call our Service Department at 866-260-0522.