



**ICETRO**

**America**

**IM-Series 48" Installation & Service Manual  
Air & Water Cooled Cubers**



## IM-Series Cuber



### Series Models

48" WIDE

REMOTE

IM-2000-RH/RC

IM-1700-RH/RC

AIR COOLED

IM-2000-AH/AC

IM-1700-AH/AC

WATER COOLED

IM-2000-WH/WC

IM-1700-WH/WC

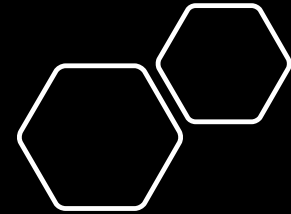

**ICE SHAPE:** Cube & Half Cube



**Cube**

$7/8" \times 7/8" \times 7/8"$



**Half Cube**

$1 1/8" \times 3/8" \times 7/8"$

IM-Series Models

# Reading The Model Number

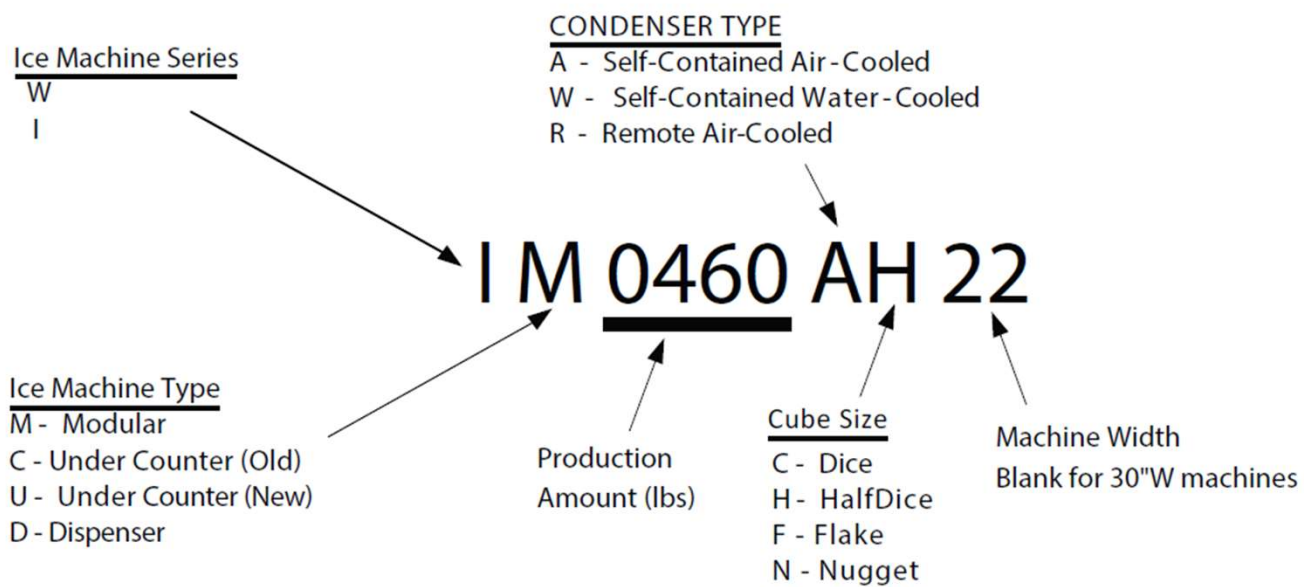
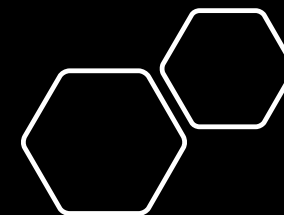

Model Number Breakdown

## Reading The Serial Number

First Letter	O	P	Q	R	S	T	U	V	W	X	Y	Z
Manufacture Year	2015	2016	2017	2018	2019	2020	2021	2022	2023	2024	2025	2026

Second Letter	A	B	C	D	E	F	G	H	I	J	K	L
Manufacture Month	JAN	FEB	MAR	APR	MAY	JUN	JUL	AUG	SEP	OCT	NOV	DEC

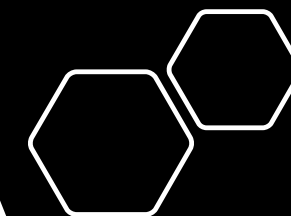
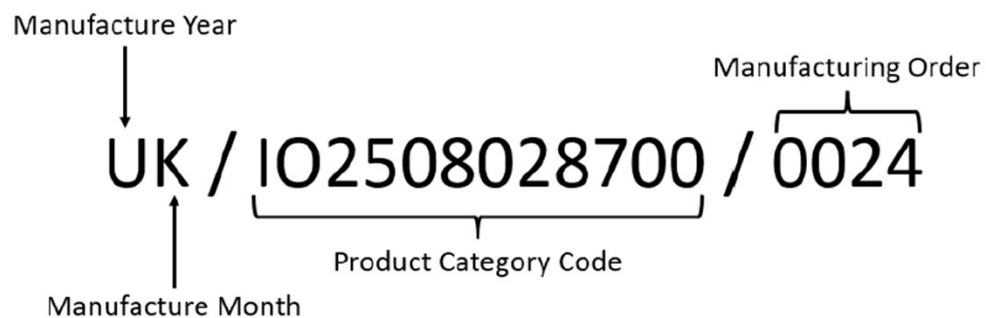

Serial Number Breakdown



**All equipment leaves our distribution points in new condition.**

When receiving new equipment, please pay close attention to the packaging for any damage to the crating. If there appears to be any exterior damage, please either note the damaged on the delivery bill of lading OR refuse it.

**Failure to note damage on BOL or refuse damaged equipment means that the receiver accepts all liability for damaged equipment.**

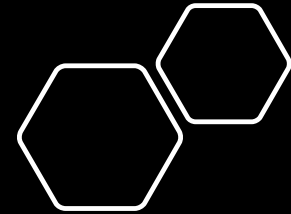

**Damage**

Receiving & Unpacking  
Equipment



### Installation, Start Up, and Check

Please double check these items before install & start-up before calling for service.

**(These items are not covered under your Labor Warranty)**

1. Has all tape and packing materials been removed from Machine?
2. Is the unit installed in a location that is away from heat generating equipment or direct sunlight?
3. Is the unit level front to back and side to side? Adjustable legs on bins and dispensers make this quick and easy.
4. Is the correct electrical power provided? Ensure the unit has the specified voltage and amperage and is on a dedicated circuit. Do not use a drop cord or power strip with any ice machine. This could cause a voltage drop and compensatory amperage spike or cause the circuit breaker to trip.
5. Check drain line pipe sizes. Insure they are ¾ inch and line drops ¼ inch per foot of run to insure both machine and bin drainage is effective.
6. Is water supplied to the unit? Water Line size, 3/8 inch, must be supplied to ensure sufficient water flow is always available. Required water pressure is 20 psi minimum and 80 psi maximum. This unit is designed to work with water temperatures of 50°F - 90°F.
7. Is the unit installed in an area with sufficient ventilation at the back for proper rejection of condenser heat? **The manufacturer requires 8" of clearance at the back & sides of the unit. Twelve (12") inches is required at the top of unit. Fresh air is taken in from the back and dispelled from the top and sides. Never block the top air vents!**
8. This unit is designed to work in ambient air temperatures of 50°F - 100°F. The remote condenser IRC-2000 operates at -5°F to 117°F.
9. Is the Unit located in an area which has air borne particulate (flour, yeast, etc) that can build mold and bacteria inside the machine or clog the filter and condenser? There are products that can be installed to help these problems.
10. Scale or Mold build-up can affect the sequence of operation, timing and production. Is a water filter installed? We recommend our exclusive Citryne Pro Ice Filtration for the best scale clean results. Scale will increase operating costs and reduce or shut down the machine's performance.
11. Do not install this unit outdoors.
12. **If you are installing an ice maker on top of an existing bin, check the bin to insure it has a baffle in the bin to keep ice from coming out of the bin door.**
13. **If you are installing the ice maker on top of a dispenser, the dispenser manufacturer must provide the top kit to prevent leaks and bin problems. Additionally, an Icetro thermostat kit is required (ITS-150-KIT).**

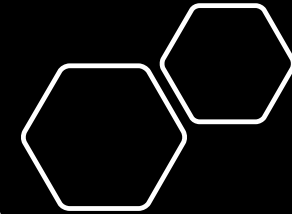

Proper Installation  
IM-Series

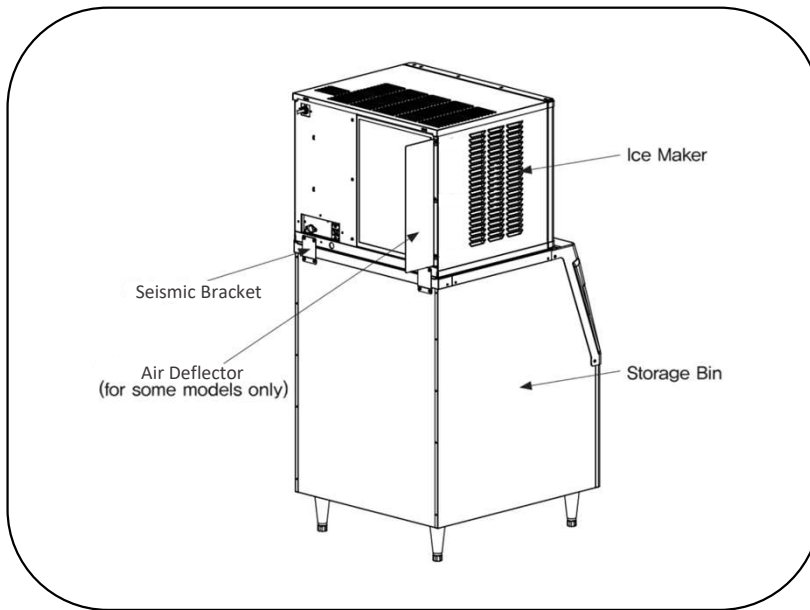

Install machine on an ice storage bin and ensure both are level to eliminate improper operation.

Additionally, it is recommended to use the supplied seismic brackets to secure the ice machine and bin together.

An air deflector is included with self-contained, air-cooled models to prevent exhausted air from returning back to the condenser.

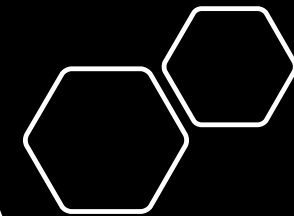

Proper Installation  
IM-Series

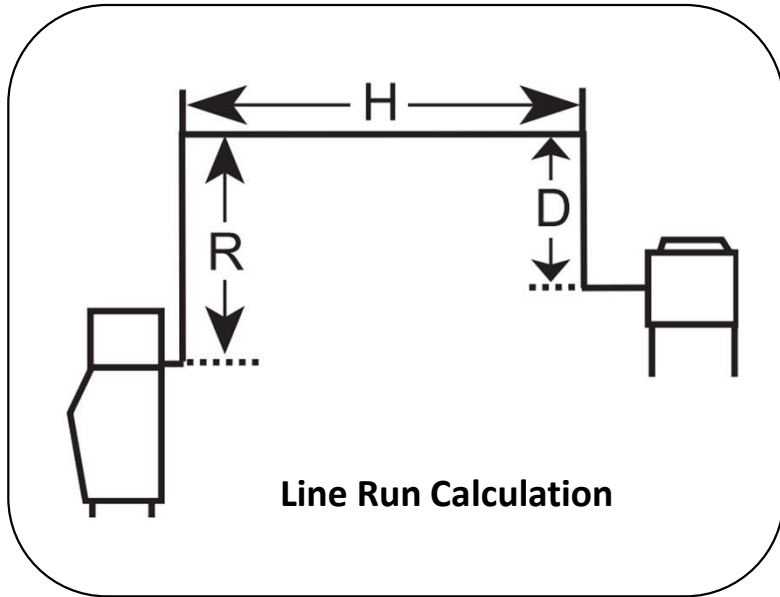

**If a line set has a rise followed by a drop, another rise cannot be made.  
Likewise, if a line set has a drop followed by a rise, another drop cannot be made.**

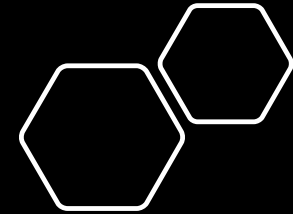

The maximum calculated line run is 150'.

- Step 1: Measured Rise (35' max) \_\_\_\_\_ x 1.7 = \_\_\_\_\_ Calculated Rise
- Step 2: Measured Drop (15' max) \_\_\_\_\_ x 6.6 = \_\_\_\_\_ Calculated Drop
- Step 3: Measured Run (100' max) \_\_\_\_\_ Calculated Run
- Step 4: Total Calculated Distance (150' max) \_\_\_\_\_ Total Distance

**It is recommended to add an s-trap for rises above 20 feet.**

Proper Installation  
Remote Machine



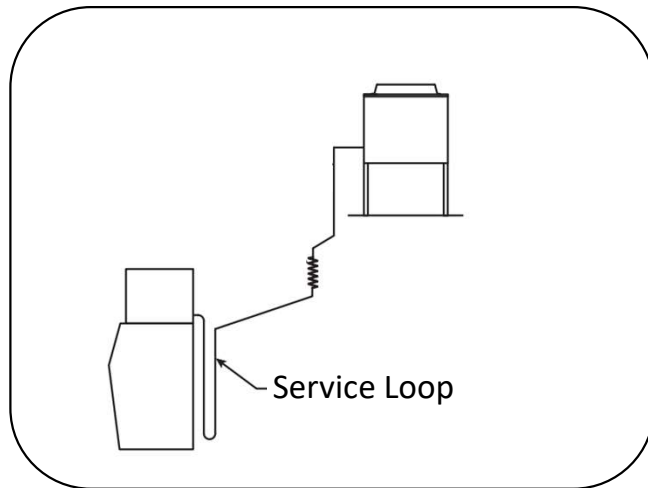

Be sure to make a service loop in the line set. This allows for easy access to the ice machine for cleaning & service.

**Do not use hard rigid copper at this location.**

Each remote ice machine ships from the factory with a refrigerant charge appropriate for installation with line sets of up to 50'. The data plate on the ice machine indicates the refrigerant charge.

Additional refrigerant may be required for installations using line sets between 50' and 100' in length. In such instances, please notify Icetero America to ensure the proper amount of refrigerant is added.

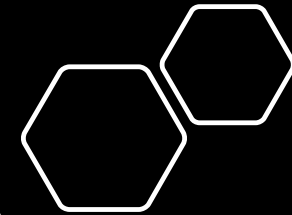

Proper Installation  
Remote Machine

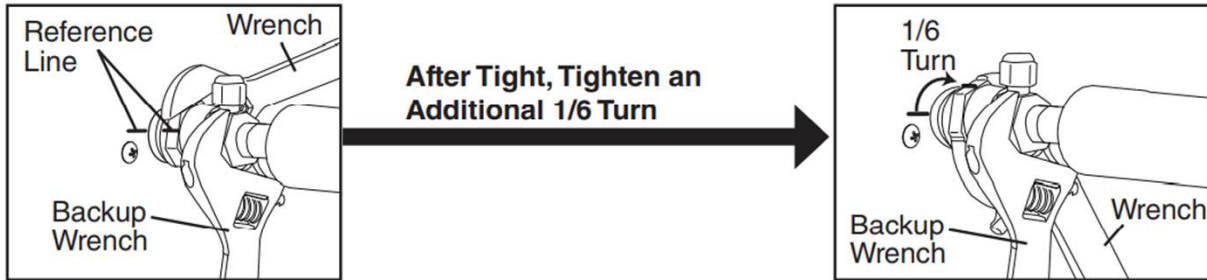

### When connecting the Quick Connect Fittings to the equipment:

- Remove the protective covers from the male & female couplings.
- Apply POE refrigerant oil to the entire male fitting, including the o-ring, diaphragm, and threads.
- Properly align the male and female fittings and then start the connections by hand to ensure the fittings are not cross threaded.
- Use a backup wrench on the back of the female coupling and tighten connection until tight.
- Mark a reference line on the female coupling and the remote condenser/ice machine. Using a backup wrench, tighten the fitting an additional 1/6" turn (pictured above).
- Using an electronic leak detector and/or soap bubbles check the connections for leaks.

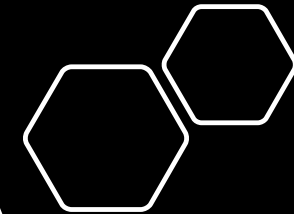
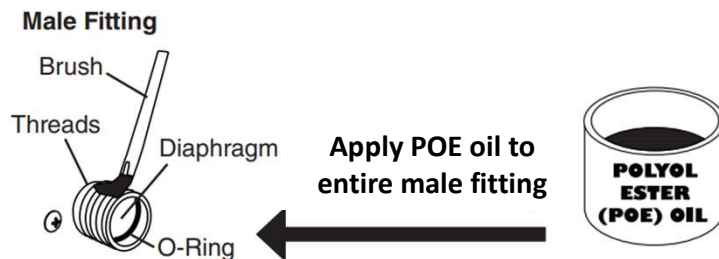

Proper Installation  
Remote Machine

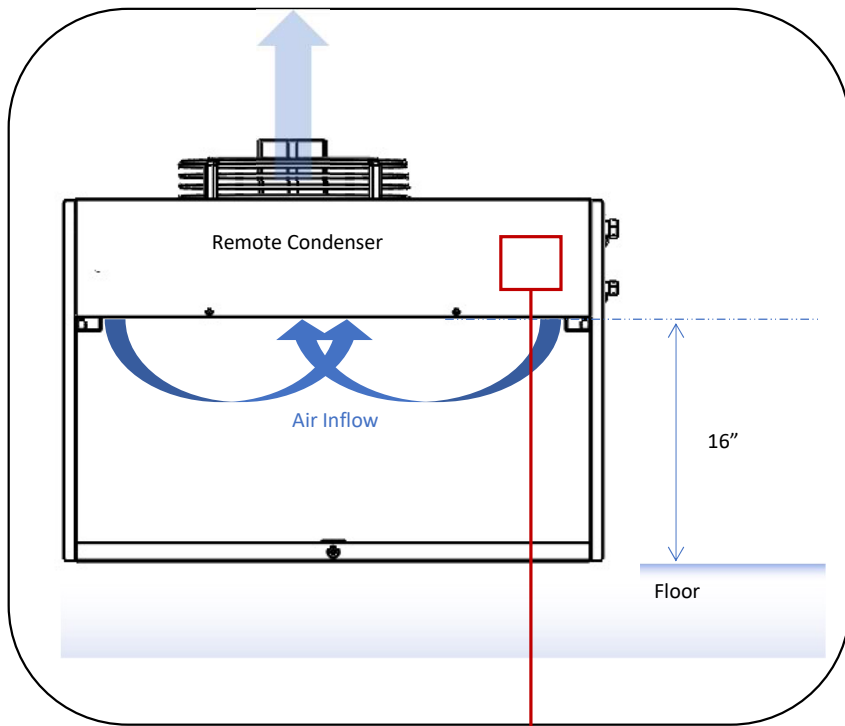

Remote condenser requires at least 16'' of clearance from the floor.

Air is taken in from the bottom and discharged from the top.

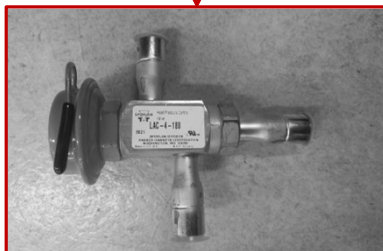

Head Master Valve for efficient head pressure regulation in colder ambient environments.

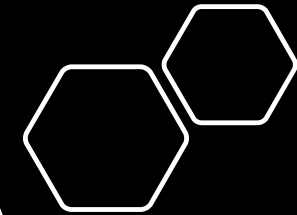

Proper Installation  
Remote Condenser

## Separate power for remote condenser not required on roof!

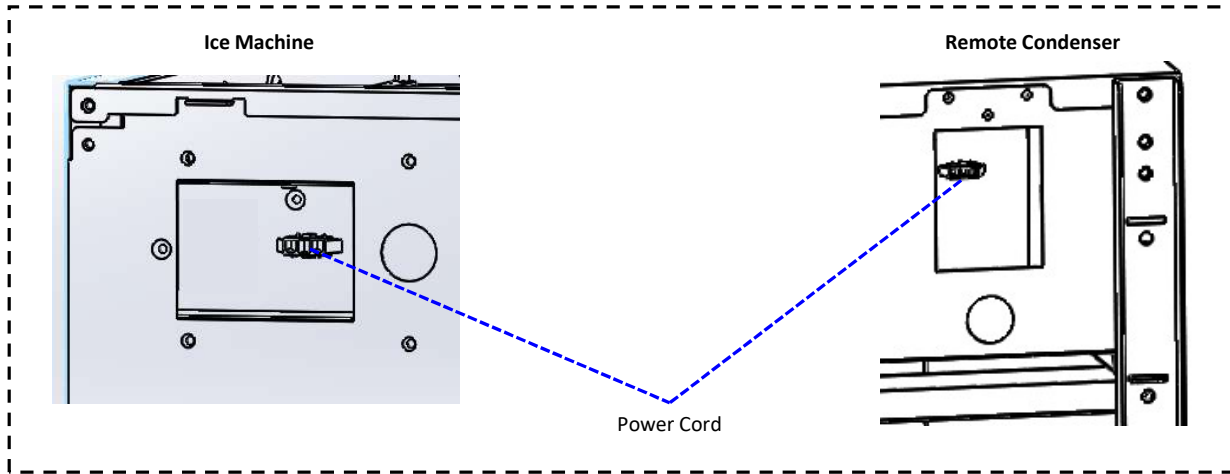

The remote condenser receives its power directly from the ice machine and is only powered when the ice machine is operating. Therefore, the condenser will not run when there is no demand for ice.

A 50' power cable is provided with each refrigeration line-set and must be run, with the refrigeration lines, between the ice machine and remote condenser.

**Please observe any & all electrical codes and splice the power cable in/out of a disconnect switch at the remote condenser should local code require it.**

Proper Installation  
Remote Condenser

## Locating the data plate.

When taking a call for service, the first thing you want to do is obtain the model and serial number to the machine. This is not only important for warranty purposes but, in some cases, in determining which part to supply to the customer.

**Doing so will help eliminate any mistakes or handwriting illegibility down the road.**



Model Name		IM-2000-AC
AC Supply Voltage		208V - 230V 60Hz, 1PH
Compressor(Freezer)	R.L.A :18.5A	L.R.A : 105A
Compressor(Refrigerator)		
Fan Motor	F.L.A : 1.15A	HP
Other Loads	A / W	
Geared Motor		
Maximum Fuse Size		30A
Max. HACR Breaker(USA Only)		A
Max. CIRC. Breaker(Canada Only)		A
Min. Circuit Ampacity		17.85A
Design Pressure(Freezer)	High	500 psig
	Low	300 psig
Refrigerant Charge(Freezer)	R410A	299.8oz
Design Pressure(Refrigerator)		
Refrigerant Charge(Refrigerator)		
Motor-Compressor Thermally Protected		
FCC IDENTIFIER		
Serial No.		WC/IO9008108700/M001

After loosening the screws on the top and bottom of the right front cover, the model/serial tag can be found.

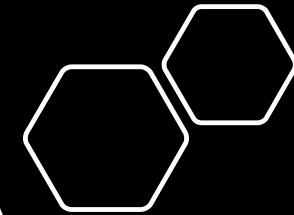

**Pre-Start Up Tips**

## Check for power.

Does the machine have power? Look at the front cover and observe if the GREEN power light is on steady (not flashing).

**If the power light is off, check to see if circuit breaker has tripped or if the machine has become unplugged.**

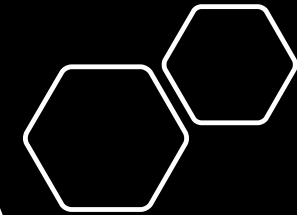

Pre-Start Up Tips

## Check for water.

Does the machine have water? Look at the front cover and observe if the YELLOW “no water” light is on steady (not flashing).



**If the “no water” light is on, check to see if the water supply valve is open, that water trough inside the machine is NOT out of place, and that the water trough is empty (no water).**



The handle on the water valve will be parallel with the water line when it's open.



The handle on the water valve will point away from the water line when it's closed.

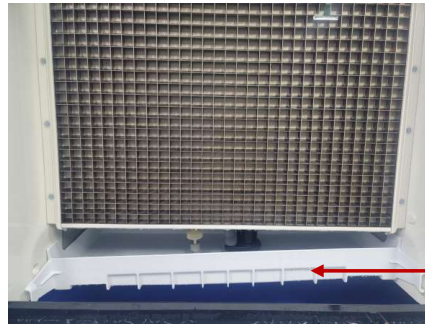

Water trough is out of alignment

**If the water supply is open, the water trough is securely in place, and there is no water in the water trough, ensure that the water level sensor is not out of place.**

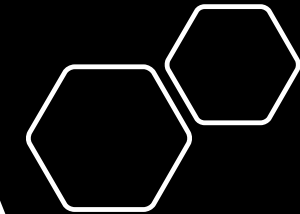

**Pre-Start Up Tips**

## Remove the water trough.

Sometimes the water level sensor and water pump can become dislodged during transportation or installation and go unnoticed.

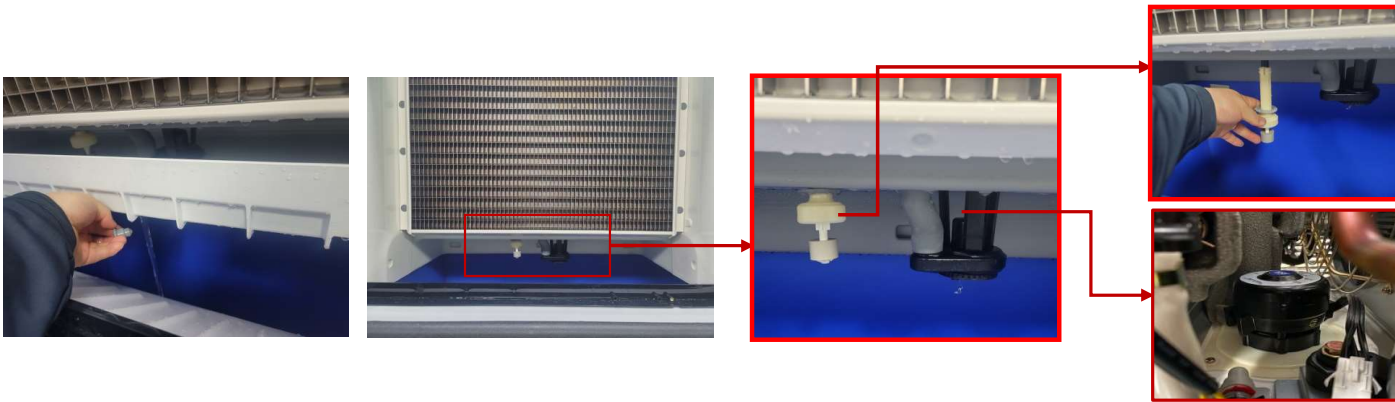

**Remove the water trough to expose the water level sensor and water pump. Pull the water level sensor down until the electrical connection is visible and make sure it's securely connected. Push the sensor back up until it "clicks" into place. Visually inspect the water pump to ensure it's level and not out of place.**

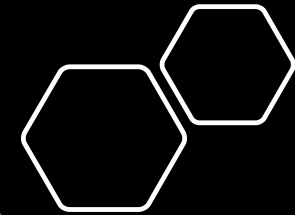

**Pre-Start Up Tips**



## Check the ice thickness sensor.

Part of the installation process is to check that the ice thickness sensor is properly adjusted. Too close to the evaporator and the customer will have hollow cubes (or worse) the machine won't make ice at all. Too far from the evaporator and you're freeze time will be too long and the customer will complain of "thick" or "chunky" ice.

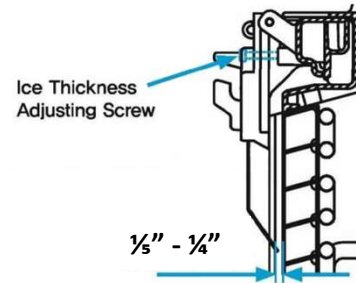
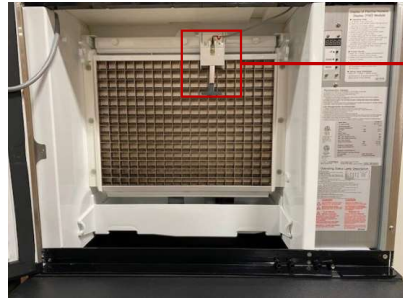

Lift the water curtain up and out of the curtain hangers to expose the ice thickness sensor. No need to bend the curtain to remove it.

**The ice thickness sensor should NOT be touching the evaporator plate. There should be approximately  $\frac{1}{5}$ " -  $\frac{1}{4}$ " of space between the sensor and the evaporator. Turn the adjustment screw on the sensor clockwise to put more space between the sensor and the evaporator. Turn the adjustment screw counter-clockwise to put less space between the sensor and evaporator.**

Pre-Start Up Tips

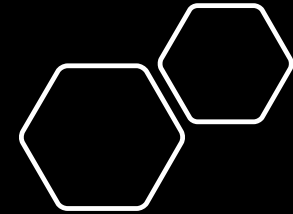

## Hinged door & access to diagnostic lamps.

The LED display is located on the right-side door. This door can be opened by loosening the screws on the top and bottom of the door. The LED assembly is located inside the door and can be disassembled and inspected. The left-side door can be opened by loosening the screws on the top and bottom of the door and releasing the latches on the top and bottom.



The door can rest on top of machine if needed. Simply press in the pin on the top/left hinge to remove front panel and place it on top of the ice machine.

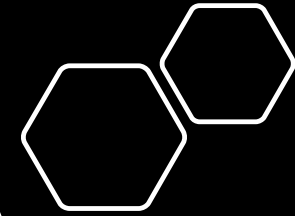

IM-Series  
Key Features

# ABS/anti-microbial interior & no tools required.

We've improved upon a classic design using studier parts that won't break the moment they're removed for cleaning and/or servicing!

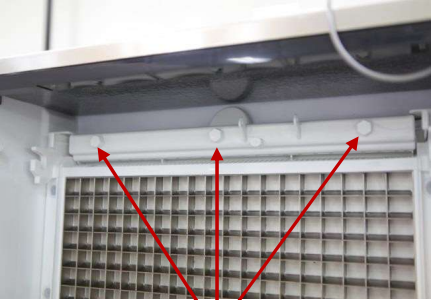

Remove 3 thumb screws.

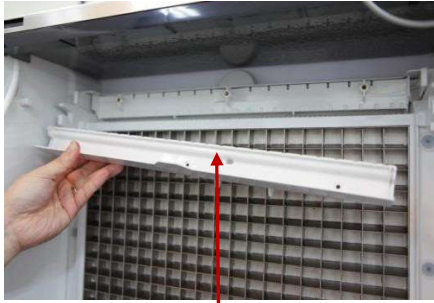

Remove distributor cover.



Hold left & right tabs in & pull distributor forward

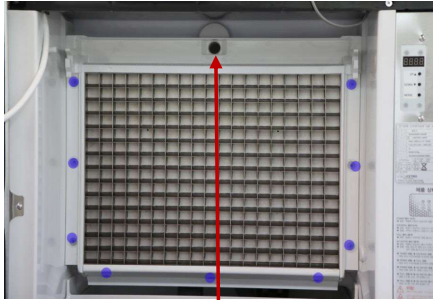

Water supply from pump, with the distributor tube removed.

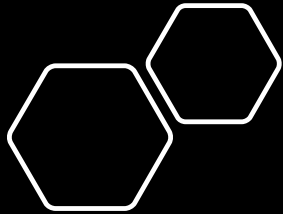

IM-Series  
Key Features

# ABS/anti-microbial interior & no tools required.

We've improved upon a classic design using studier parts that won't break the moment they're removed for cleaning and/or servicing!



Our water curtain design is considered the best in the industry! Study curtain hangers allow you to simply pull the curtain open about 30° then lift up & pull forward to remove!

**No need to bend the curtain and risk breaking it any longer!**

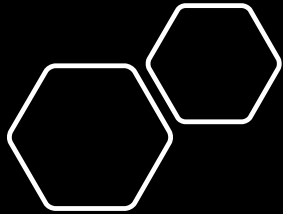

IM-Series  
Key Features

# Heavy-duty, non-corrosive platform.

Every ice machine needs a solid foundation. Ours comes with a vacuum formed, high-density foam injected base, which is resistant to rust and corrosion!

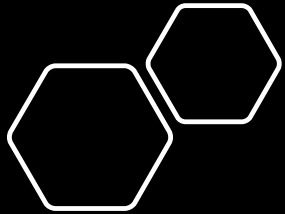
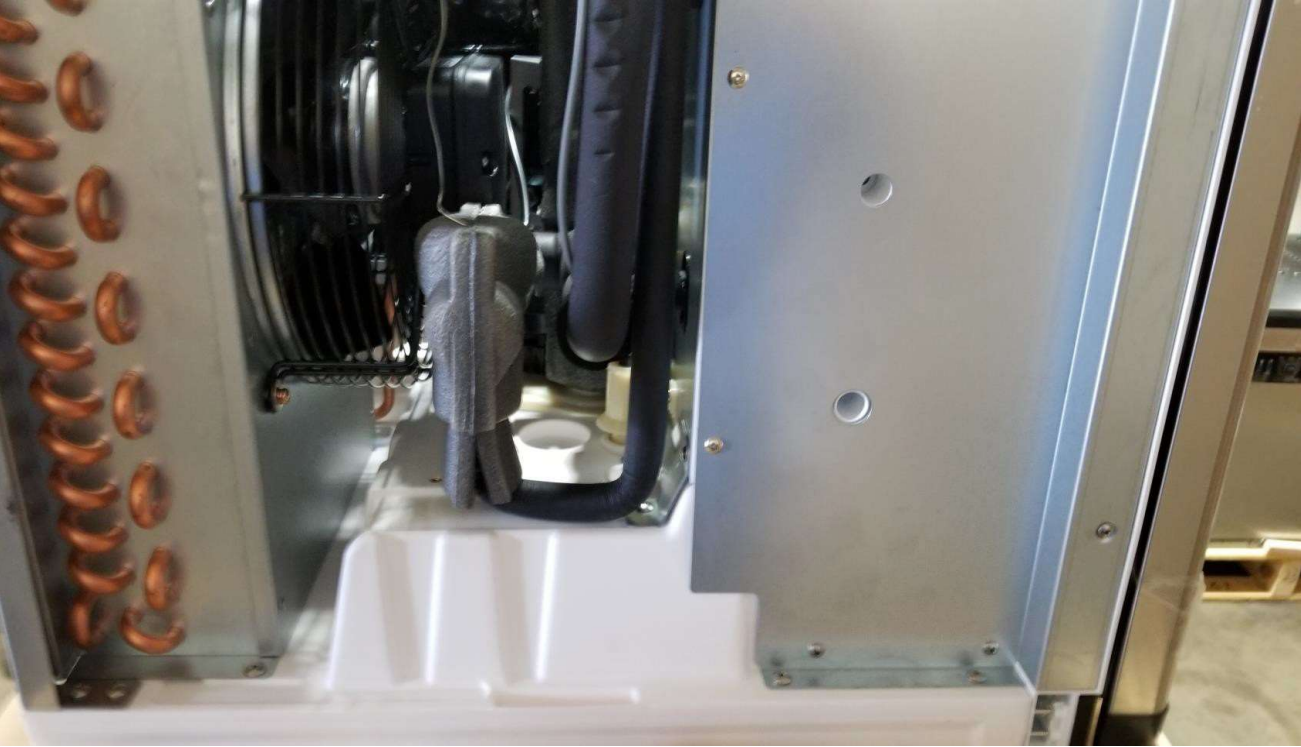

IM-Series  
Key Features



# Washable & magnetic air filter.

That's right... it's magnetic. No more plastic clips breaking and/or getting lost!

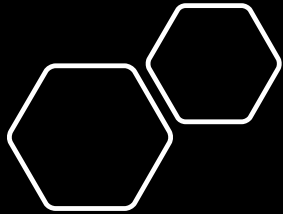
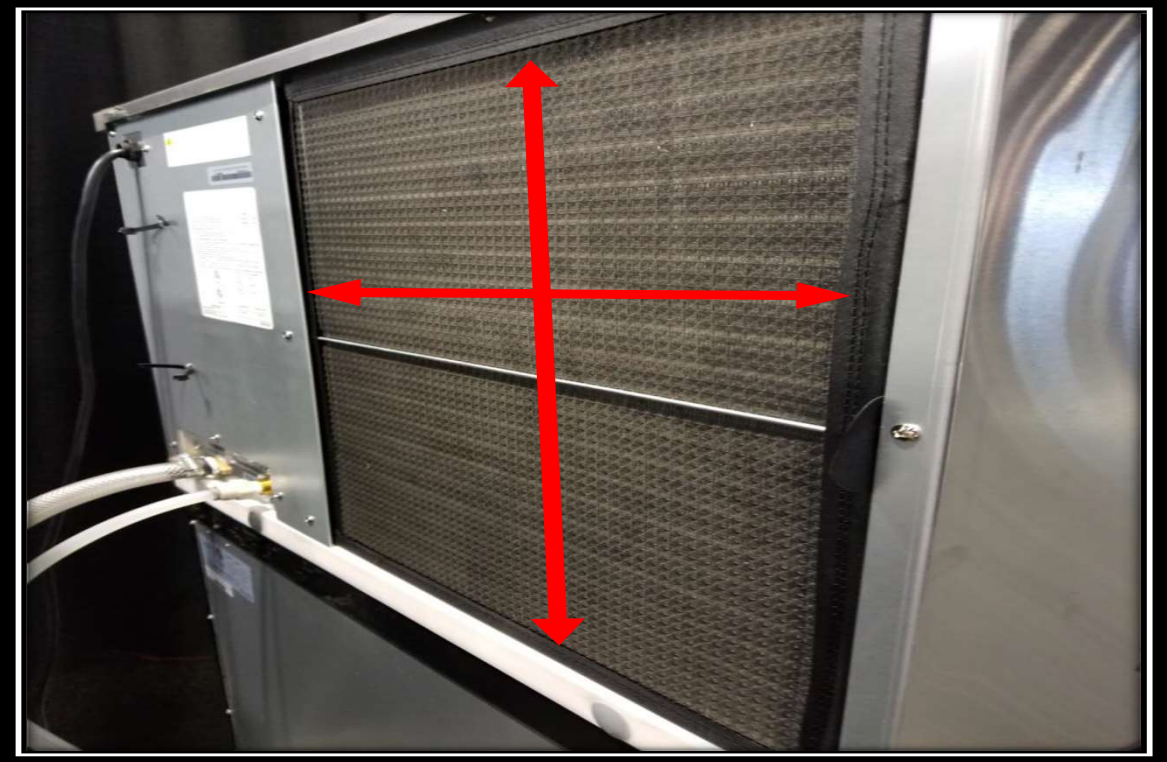

IM-Series  
Key Features

# Ice production managed by magnetic bin switch.



**BIN SWITCH:  
MAGNET ON WATER CURTAIN.  
SWITCH IN CONTROL BOX.**

### Magnets are inserted inside the water curtain

During the freeze cycle, the water curtain switch is closed. When the ice thickness control senses water, the machine goes into defrost. The ice will release within 1-1 ½ minutes and drops into the bin. The water curtain opens, then closes, putting the machine back into freeze. When the ice bin is full, ice will prevent the curtain from closing and the machine will shut down. When ice is drawn down, the curtain will close, and the machine will start.

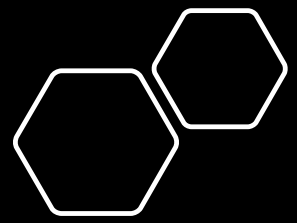

IM-Series  
Key Features

# Removal of the water pump.

The pump motor is secured in a dry environment. To remove, remove the water trough, pull down on the water pump, and disconnect the electrical.

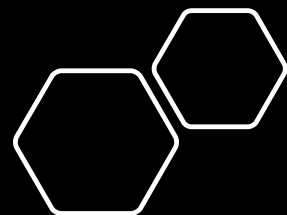

IM-Series  
Key Features



# IM-Series Drop Zone Chart.

1) IM-1700/2000 Series(48")

(A)48" (B) 24.9" (C) 17.3" (D) 13.2" (E) 2.3" (F) 1.9"

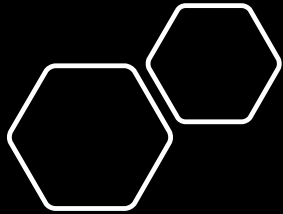
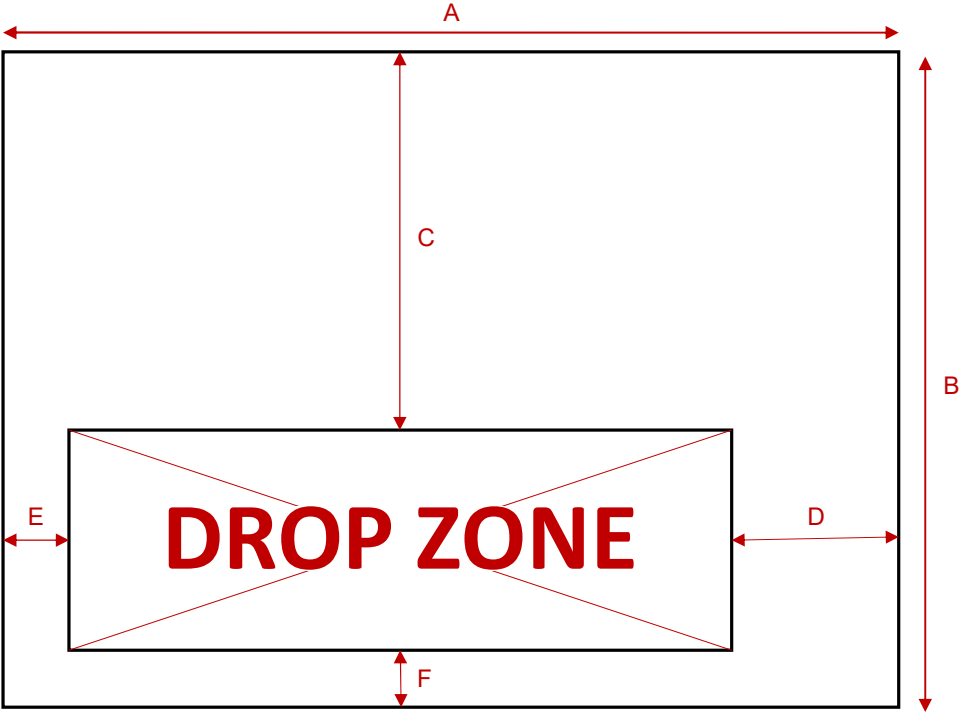

IM-Series  
Drop Zone

# IM MODULAR SEQUENCE OF OPERATION

## INITIAL START-UP IM SERIES

1. Move the ICE-OFF-CLEAN switch to the “ICE” position.
2. Water inlet solenoid energizes and allows water trough to fill until water reaches the low-level sensor on the water sensor probe.
3. Dump valve & water pump energize to discard the remaining water in the trough for 20 seconds.
4. Water valve energizes and allows water trough to fill until water reaches the high-level sensor on the water sensor probe.
5. Five seconds later, the hot gas valve energizes for 10-20 seconds to allow for pressure equalization and to reduce compressor starting torque.
6. The hot gas solenoid is de-energized once the compressor and condenser fan are energized for a 15 second evaporator pre-chill.
7. The water pump is energized after the 15 second pre-chill, circulating water over the evaporator.
8. The water inlet solenoid is energized and supplies additional water once water level sits below the low-level sensor.  
(Happen in 1<sup>st</sup> cycle only. *From the second cycle onward, even if the low water level is detected, no additional water supplied*)
9. Water circulates over evaporator for approximately 10 minutes.
10. When water contacts the ice thickness probe for 7 continuous seconds, the machine enters the defrost cycle (*Harvest*).
11. With compressor running, the hot gas valve is energized for approximately 1.5 minutes or until the ice is harvested.
12. The defrost cycle is terminated when ice drops from the evaporator and causes the bin switch to open and close.
13. If the ice bin level is sufficiently high enough that ice is trapped between curtain and evaporator, the machine stops operation and the “Full Lamp” on front of machine is lit.

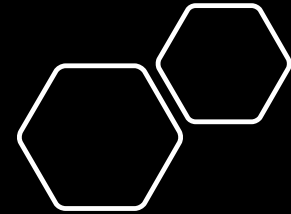

## NORMAL CONTINUOUS SEQUENCE OF OPERATION DURING ICE MAKING MODE IM SERIES

1. With water curtain closed, the dump valve and water valve are energized for 15 seconds. With brackish water emptied from the sump trough, the water pump and dump valve are de-energized.
2. After 15 seconds the dump valve is de-energized, but the water valve is energized until the water level reaches high level sensor, plus an additional 15 seconds (adjustable). The fan motor is energized after 5 seconds with the water curtain closed.
3. When water contacts the ice thickness sensor for 7 continuous seconds, the machine enters the defrost cycle (Harvest).
4. The hot gas valve is energized for approximately 50 seconds. At this time, the water pump and water supply valve are de-energized.
5. The compressor and hot gas valve continue to defrost evaporator until ice falls from evaporator plate.
6. Ice falling from evaporator causes the water curtain open & close signaling defrost termination.
7. With the Curtain closed, the machine begins another cycle.

**When the machine shuts down due to full bin level, with the 'Full Lamp' lit, removal of ice from the bin will cause the curtain to close, which closes the curtain switch and energizes the machine with the same steps outlined in the 'INITIAL START-UP'.**

**Normal continuous operation starts a new cycle with steps 1 through 7.**

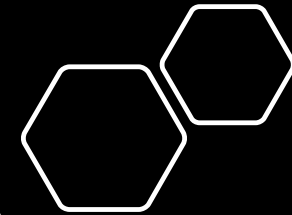

## WASH CYCLE FOR ALL IM-SERIES MACHINES

**NOTE:** If the machine is in the 'ICE' mode, first place the power switch in the 'OFF' position and wait for the machine to finish its current cycle and stop.



1. With the power switch in the 'OFF' position, add the appropriate amount of ice machine cleaner or sanitizer to the water trough.

**WARNING!** Do NOT mix ice machine cleaner and sanitizer together. Use one or the other separately. Mixing cleaner & sanitizer together can cause severe bodily injury.

2. Place the power switch on the front panel to the 'WASH' position to run the wash cycle.
3. Water inlet solenoid valve opens for a 30 seconds to fill.
4. Water pump then runs for 10 minutes, circulating the mix through the water trough, pump, connecting hose, water distributor, and evaporator.
5. Dump valve solenoid opens for a 40 second flush.
6. Water inlet solenoid valve opens for a 30 second fill.
7. Water pump then runs for 1.5 minutes to circulate fresh water.
8. Dump valve solenoid opens for a 40 second flush.
9. Steps 5-7 repeats five times.

**WARNING!** Use ONLY nickel safe ice machine cleaner.

Cleaning Agent (Nickel Safe Cleaner)	Water
150 ml (16 oz)	4 Liters
Disinfectant (Nickel Safe Cleaner)	Water
200 ml	5 Liters

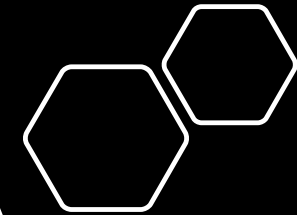

# CIRCUIT DIAGRAM

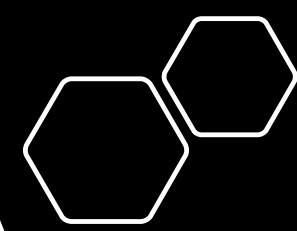
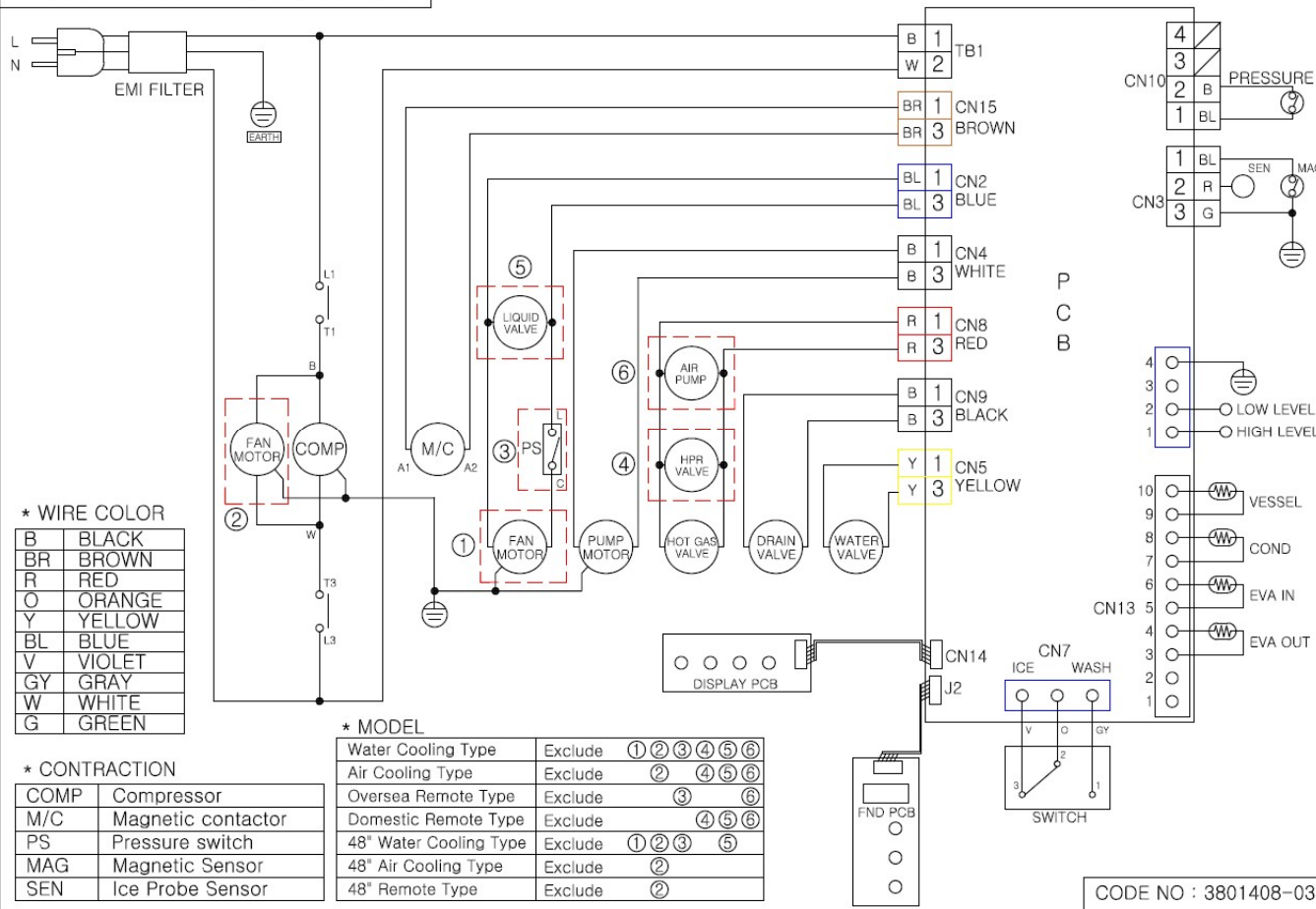

IM-Series  
Wiring Diagram

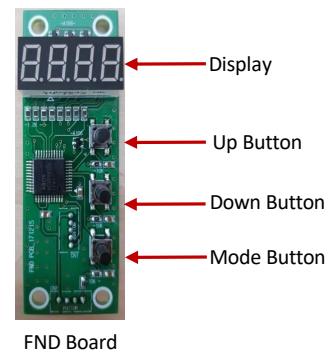
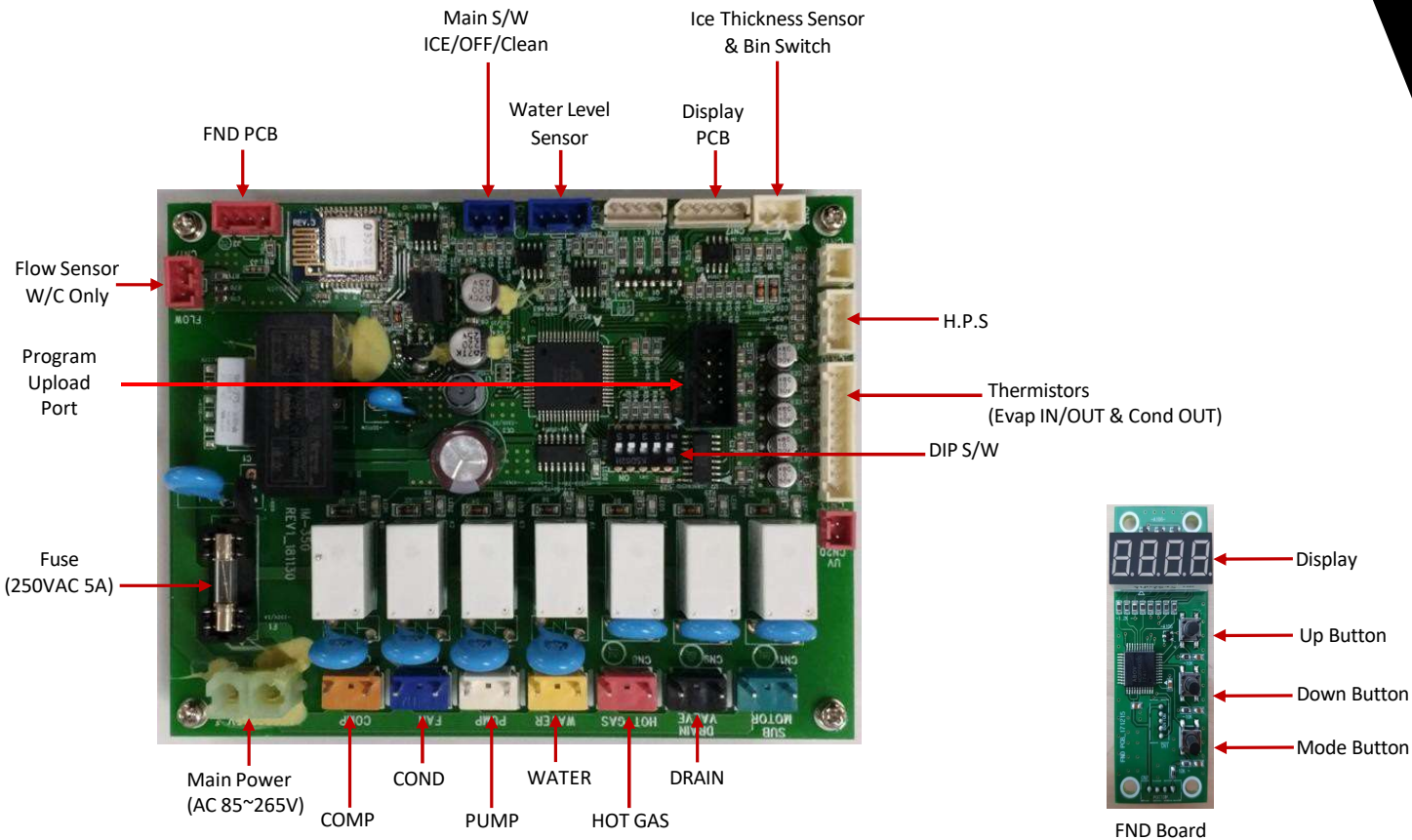

Relays light when energized with a GREEN light on the PCB for simple diagnostics.

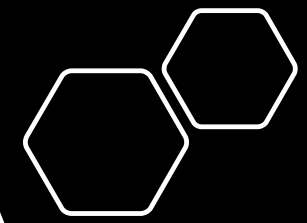

IM-Series  
PCB & FND

# Switches will be upside-down when facing the PCB

Turning dip switches down will put them in the "ON" position!

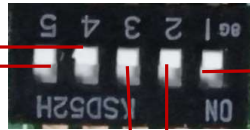

4	5	Descriptions
ON	ON	IM-0350/0460/0550-22 Series(22")
ON	OFF	IM-1100 Series
OFF	ON	IM-1100 Remote, IM-1700/2000(48")
OFF	OFF	IM-0350/0460 /0550/0680 Series(30")

3	Descriptions
ON	Air cooled
OFF	Water cooled

2	Descriptions
ON	Use drain function
OFF	Do not use drain function (All the drain time : OFF)

1	Descriptions
ON	Drain after harvest
OFF	Drain after ice making

## Initial Dump: Basic Process

- 1) It only works at the beginning of the first "ice making" cycle.
- 2) Check the water level sensor and operate the dump valve and water pump in case of high-water level.
- 3) When the low level is detected, the dump valve and the water pump are stopped.
- 4) The maximum drain time is 30 seconds.
- 5) After the initial drainage is completed, the water supply enters operation.

Model	Initial drain time	Drain after harvest	Drain after ice making	Water supply delay time	Pump stop time during ice making	Harvest Assist Temperature
22", 30", 48" Series	20s	10s	10s	0s	0s	0°C
IM-1100W	20s	30s	10s	0s	0s	0°C



IM-0460/0550  
Water Cooled

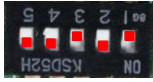

IM-0350/0460  
0550-22 (22")  
Water Cooled

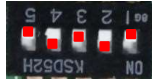

IM-1100  
Water Cooled

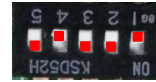

IM-1100 Remote  
IM-1700/2000 Air Cooled

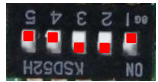

IM-0350/0460  
0550/0680  
Air Cooled

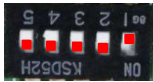

IM-0350/0460  
0550-22 (22")  
Air Cooled



IM-1100  
Air Cooled



IM-1700/2000  
Water Cooled

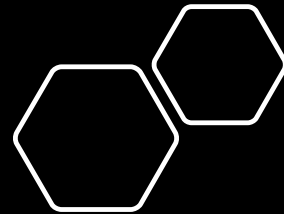

IM-Series  
PCB Dip Switch Settings

## Testing The Float Switch

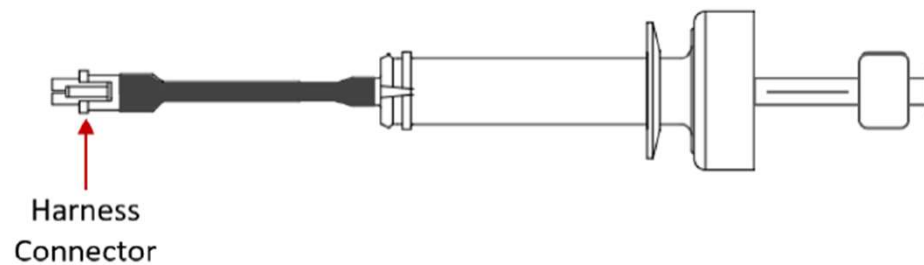

To test the float switch, simply check for continuity between the two wires found in the harness connector.

- When the float is in the down position, the switch is closed.
- When the float is in the up position, the switch is open.

If the float switch tests good, check the wiring harness for continuity.

If the float switch and the harness test good, the problem is with the control board.

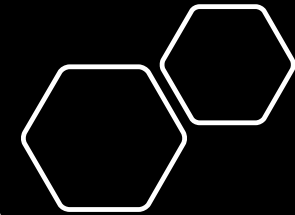



### Pinching Tubing

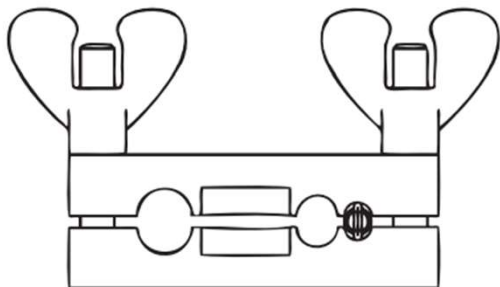
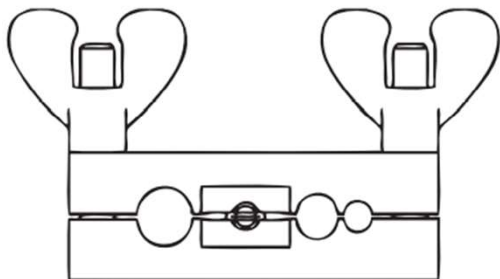

### Re-rounding Tubing

#### Important

This is a required in-warranty repair procedure.

1. Disconnect power to the ice machine.
2. Follow all manufacturer's instructions supplied with the pinch-off tool. Position the pinch-off tool around the tubing as far from the pressure control as feasible. (See the figure on next page.) Clamp down on the tubing until the pinch-off is complete.

#### ⚠ Warning

Do not unsolder a defective component. Cut it out of the system. Do not remove the pinch-off tool until the new component is securely in place.

3. Cut the tubing of the defective component with a small tubing cutter.
4. Solder the replacement component in place. Allow the solder joint to cool.
5. Remove the pinch-off tool.
6. Re-round the tubing. Position the flattened tubing in the proper hole in the pinch-off tool. Tighten the wing nuts until the block is tight and the tubing is rounded.



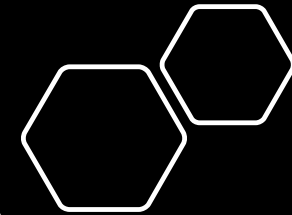
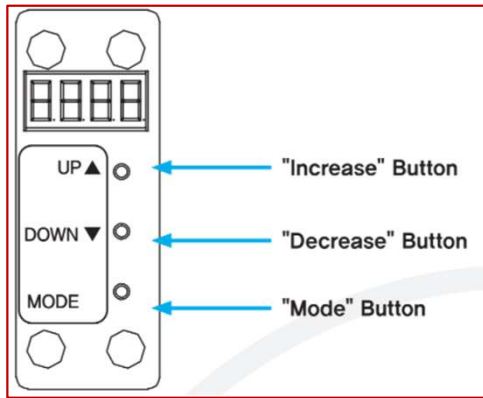

## • Operating Order

1. In standby mode the Flexible Numeric Display (FND) is off.
2. When you press the "MODE" button, the FND will turn on and either show the last error code ( if there is one) OR the first setting.
3. While the FND is on, press the "UP" or "DOWN" button to move through the available settings.
4. Pressing the "MODE" button again will display the default value for the current setting.
5. Use the "UP" or "DOWN" buttons to change the default value, followed by the "MODE" button to save the new value.
6. If there are two values for one setting, press the "MODE" button to move between the two value settings.
7. The FND will automatically turn off when it has no input for 30 seconds.

## • Forced Harvest

1. Press the "UP" + "DOWN" simultaneously for 3 seconds to force the harvest cycle on the ice machine.

## • Forced Drain

1. Press the "DOWN" + "MODE" buttons simultaneously for 3 seconds to force a 30 second drain function.

## • Reset to Default Values

1. Pressing the "UP" + "DOWN" + "MODE" buttons simultaneously for 3 seconds will reset the FND values to their default settings.
2. Please refer to the user manual when setting the "Drain Time After Harvest" value.

**Error codes are also listed in the owner's manual.**

IM-Series  
Service Tips

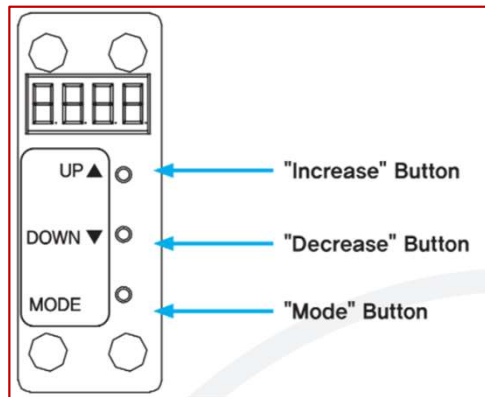

"Increase" Button

"Decrease" Button

"Mode" Button



The Flexible Numeric Display (FND) allows for the adjustment of the flush time, which can help reduce scale accumulation in the water trough, preventing it from clogging other vital parts, such as the water pump and water distribution tube.

Additionally, the FND allows for the adjustment of the water fill time, which will extend the fill time for a set amount once the high-level sensor is sensed.

The fill time can be adjusted between 0-5 seconds, in 1 second increments. The flush time can be adjusted between 0-90 seconds, in 1 second increments.

See next page for all FND functions.

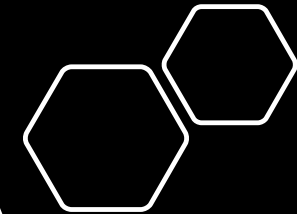

IM-Series  
Service Tips

## Flexible Numeric Display (FND) Functions

Item	Display	Description	Set range	Default
Initial Drain Time		Adjust initial drain time.	0 ~ 30 sec (by 1 second)	20 sec
Drain Time after Harvest		Adjust drain time after harvest.	0 ~ 90 sec (by 1 second)	10 sec
Drain Time after ICE Making		Adjust drain time after making ice.	0 ~ 30 sec (by 1 second)	10 sec
Water Supply Delay Time		Adjust the delay time after detecting high water level. (0.5 seconds) Maximum water supply time: 5 minutes If high water level has already been detected when the water is supplied, the delay is not applied.	0 ~ 30 sec (by 1 second)	15 sec (Different by model)
Harvest Assist Temperature (Optional)		With hot gas, run the sub-motor if the preset condenser temperature is exceeded.	-56° ~ 138°F (by 1°F)	0°F
Pump Standby Time during Ice Making (Optional)		Stops pump for the preset time when the water temperature in the water vessel turns to 0°C.	0 ~ 120 sec (by 1 second)	15 sec
Temperature Selection		Choose Celsius or Fahrenheit.	°C / °F	°C
Water Vessel Water Temp. (Optional)		Displays current water temperature in the water vessel.	-56° ~ 138°F (by 1°F)	N/A on IM
Condenser Outlet Temperature		Display current temperature at the condenser Outlet.	32° ~ 212°F (by 1°F)	
Evaporator Inlet Temperature		Display current temperature at the evaporator Inlet.	-56° ~ 138°F (by 1°F)	
Evaporator Outlet Temperature		Display current temperature at evaporator outlet	-56° ~ 138°F (by 1°F)	

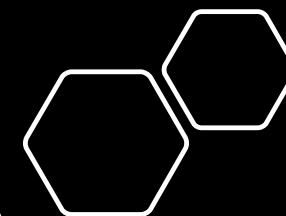



#### Operating Status Lamp Description

##### **POWER Lamp (Green)**

On: When the power is connected to the machine.

##### **ICE/WASH Lamp (Green)**

On: When in the ice making mode. (Switched to ICE)

Flickers: When in the cleaning mode. (Switched to WASH)

##### **FULL Lamp (Yellow)**

On: When the Ice Storage Bin is filled with ice. When the water curtain is open for 10 seconds or longer

##### **NO WATER Lamp (Yellow)**

On: When insufficient water supplied to the machine. (Error code 15).

Flickers: When entering the harvest mode after making ice, when the water level sensor (high/low level) detects water level (water). (Error code 16).

##### **POWER Lamp Flickers & ICE/WASH Lamp Flickers**

When the maximum ice making time (65 minutes) is exceeded. (Error code 11).

##### **POWER Lamp Flickers & FULL Lamp Flickers**

When the maximum harvest time (5 or 8 minutes) is exceeded. (Error code 12).

##### **POWER Lamp Flickers & NO WATER Lamp Flickers**

When the ice making cycle exceeds 30 minutes and evaporator temperature is higher than 32 deg. F. (Err. 01).

##### **FULL Lamp Flickers & NO WATER Lamp Flickers.**

High pressure cut-out occurred once. (Error code 13).

##### **FULL Lamp Flickers & NO WATER Lamp On.**

High pressure cut-out occurred three consecutive times. (Error code 14)

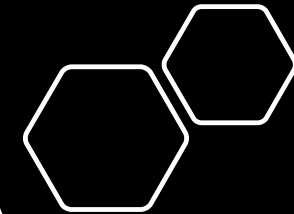

Lamp Indicators  
IM-Series

## Tip 1: Error Code 1 or 3 Potential Causes



**Evap temp 32°F or higher  
after 30 minutes in freeze.**

**OR**



**Evap temp exceeds 23°F  
after 30 minutes in freeze.**

### Refrigerant:

- Is the machine overcharged?
- Is hot gas leaking past hot gas solenoid valve?
- Is TXV flooding the evaporator with refrigerant?
- Headmaster stuck in bypass? (REMOTE ONLY)

### Electrical:

- Is suction line thermistor open or shorted?
- Defective fan cycling control?

### Water:

- Is water inlet solenoid valve leaking by?
- Water regulator restricting water flow?  
(WATER-COOLED ONLY)

### Air:

- Is the air filter or condenser clogged?
- Is the condenser discharge air being recycled back into the condenser?

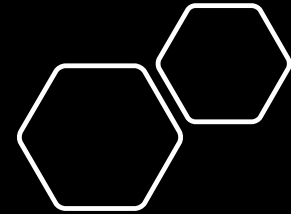

## Tip 1: Error Code 11 Potential Causes



**Ice thickness probe not sensing water contact after 65 minutes 3 consecutive times.**

### Water:

- Is there sufficient water supply?
- Is the water pressure below 20psi?
- Is the water level sensor scaled up or giving a false full level reading?
- Does the water pump have power but it's not running?
- Is the water distribution tube scaled up?
- Is the was dump valve dirty or stuck open?

### Ice Thickness Sensor:

- Is the ice thickness sensor adjusted too far out?
- Is the ice thickness sense faulty and not reading properly?

### Refrigerant:

- Is the system undercharged?
- Is the TXV starving the evaporator?
- Is the hot gas valve leaking?

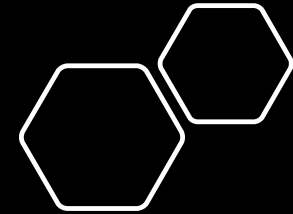

## Tip 1: Error Code 12 Potential Causes



**Curtain switch is not detected  
5 minutes into harvest 3  
consecutive times.**

### Electrical:

- Is the curtain sensor faulty?
- Has the curtain magnet fallen off the water curtain?
- Dose the hot gas valve have power, but it's not opening?
- Is the ice thickness probe too close to the evaporator?

### Refrigeration:

- Dose the hot gas valve have power, but it's not opening?

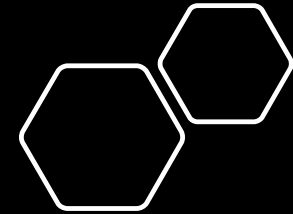



## Tip 1: Error Code 13 & 14 Potential Causes



High pressure switch opens due to high discharge pressure.

OR

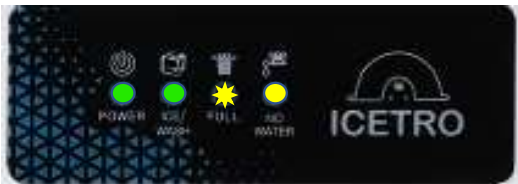

High pressure switch opens due to high discharge pressure 3 consecutive times.

### Water:

- Is water supply to condenser insufficient? (WATER COOLED ONLY)
- Is water supply to condenser below 20psi? (WATER COOLED ONLY)

### Air:

- Is there poor air circulation?
- Is the condenser air filter dirty and in need of cleaning?
- Is the air condenser dirty and in need of cleaning?
- Is the air condenser blocked.
- Does the condenser fan motor have power from PCB?
- Is the condenser fan motor capacitor faulty/bad?
- Is the condenser fan motor faulty/bad?
- Is the fan blade broken?

### Refrigeration:

- Is the system properly charged?
- Is the hot gas solenoid valve open/leaking?
- Is the headmaster stuck in bypass?

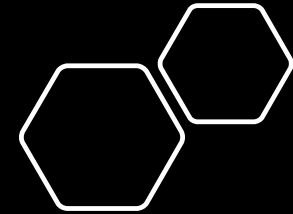

## Tip 1: Error Code 15 Potential Causes



**Water level sensor (high-level probe) is not detected after 5 minutes.**

Water:

- Is the water supply to the machine open?
- Is the water supply pressure below 20psi?
- Does the water inlet solenoid have power to it from PCB?
- Is the water inlet solenoid valve clogged with scale/debris?
- Is there a water filter that's overdue to be changed?
- Does the water level sensor appear scaled up and in need of cleaning?
- Is water overflowing the water trough, indicating the water level sensor is not sensing a full trough?
- Is the trough full of water, but the water level sensor is indicating that the machine is empty?
- Is the dump valve stuck open?

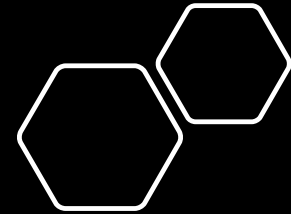

## Tip 1: Error Code 16 Potential Causes



**Water level sensor detects water at the high-level probe at end of freeze cycle.**

Water:

- Is the water level sensor faulty or in need of cleaning?
- Is the water inlet valve stuck open or allowing water to bleed through it.
- Faulty PCB.

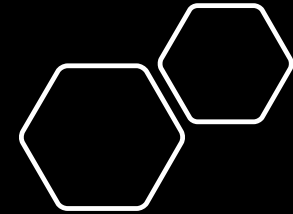

IM-Series  
Error Codes

## Tip 1: Error Code 17 Potential Causes

In case of "FULL"



In case of "OFF"



**Excessive cooling is detected when the machine is OFF or FULL.**

Water:

- Is the water regulator faulty or stuck open?
- Is liquid-line thermistor open or shorted? Temporarily disconnecting the thermistor from the PCB will allow the machine to continue to make ice even if the error continues to occur.

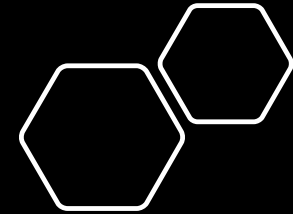

## Tip 1: Error Code 18 Potential Causes



**Dump valve activated, but water level sensor does not read low level probe within 5 minutes.**

Water:

- Is the dump valve faulty or in need of cleaning?
- Does the dump valve have power from the PCB?
- Is the drain line clogged with scale/debris?
- Is the water level sensor faulty/bad?
- Is the water pump faulty or in need of cleaning?
- Is the water pump getting power from the PCB?

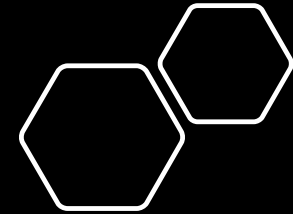

## P/T Chart & Cycle Times

Model	Ambient Temp.(C/F)	10/50	21/70	32/90	38/100
IM-2000-RH/RC	Water Temp.(C/F)	10/50	10/50	21/70	32/90
	Ice Production(lb/d)	1907	1943	1714	1499
	Freeze Cycle Time(min)	9.2	8.7	10.5	12.4
	Defrost Cycle Time(min)	1.5	1.4	1.2	1.1
	1 Cycle Time(min)	10.4	10.1	11.7	13.5
	Electric Consumption(W)	2740	2780	2890	3010
	Head Pressure[Peak] (psig)	334.7	359.1	401.6	449.5
	Suction Pressure Peak (psig)	39.9	39	39.2	42
	Evaporator Inlet Temp.(F)	-0.4	-0.94	6.4	8.4

Model	Ambient Temp.(C/F)	10/50	21/70	32/90	38/100
IM-1700-RH/RC	Water Temp.(C/F)	10/50	10/50	21/70	32/90
	Ice Production(lb/d)	1726	1767	1557	1345
	Freeze Cycle Time(min)	9.7	10	12	14
	Defrost Cycle Time(min)	2	1.6	1.3	1.2
	1 Cycle Time(min)	11.7	11.5	13.3	15.2
	Electric Consumption(W)	2230	2280	2360	2460
	Head Pressure[Peak] (psig)	330	350.5	396.8	454.5
	Suction Pressure Peak (psig)	114.2	118.1	38	41.6
	Evaporator Inlet Temp.(F)	-2.02	-2.56	-2.2	0.32

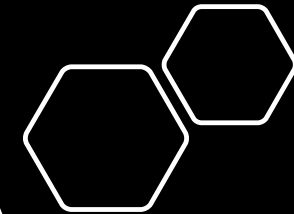

IM-Series  
Service Tips

## P/T Chart & Cycle Times

Model	Ambient Temp.(C/F)	10/50	21/70	32/90	38/100
IM-2000AH/AC	Water Temp.(C/F)	10/50	10/50	21/70	32/90
	Ice Production(lb/d)	2058	2032	1708	1397
	Freeze Cycle Time(min)	8.4	9.0	11.4	13.8
	Defrost Cycle Time(min)	1.4	1.1	0.7	0.7
	1 Cycle Time(min)	9.8	10.1	12.1	14.6
	Electric Consumption(W)	2970	3050	3.370	3.680
	Head Pressure[Peak] (psig)	338.3	340.6	406.7	460.2
	Suction Pressure Peak (psig)	33.3	32.9	38.2	39.1
	Evaporator Inlet Temp.(F)	-5.98	-7.06	-1.66	-2.2

Model	Ambient Temp.(C/F)	10/50	21/70	32/90	38/100
IM-1700AH/AC	Water Temp.(C/F)	10/50	10/50	21/70	32/90
	Ice Production(lb/d)	1788	1747	1398	1147
	Freeze Cycle Time(min)	10.4	10.8	14.3	16.9
	Defrost Cycle Time(min)	1.1	1.0	0.8	0.7
	1 Cycle Time(min)	11.6	11.8	15.1	17.6
	Electric Consumption(W)	2420	2540	2700	2940
	Head Pressure[Peak] (psig)	331.9	336.0	390.5	449.6
	Suction Pressure Peak (psig)	36.5	38.0	39.3	44.3
	Evaporator Inlet Temp.(F)	-5.08	-3.1	-2.38	1.94

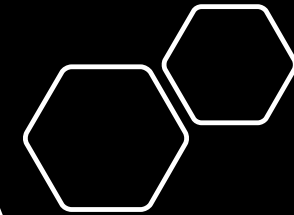

IM-Series  
Service Tips

# Tubing Schematic

IM-1700/2000 Air or Water Cooled

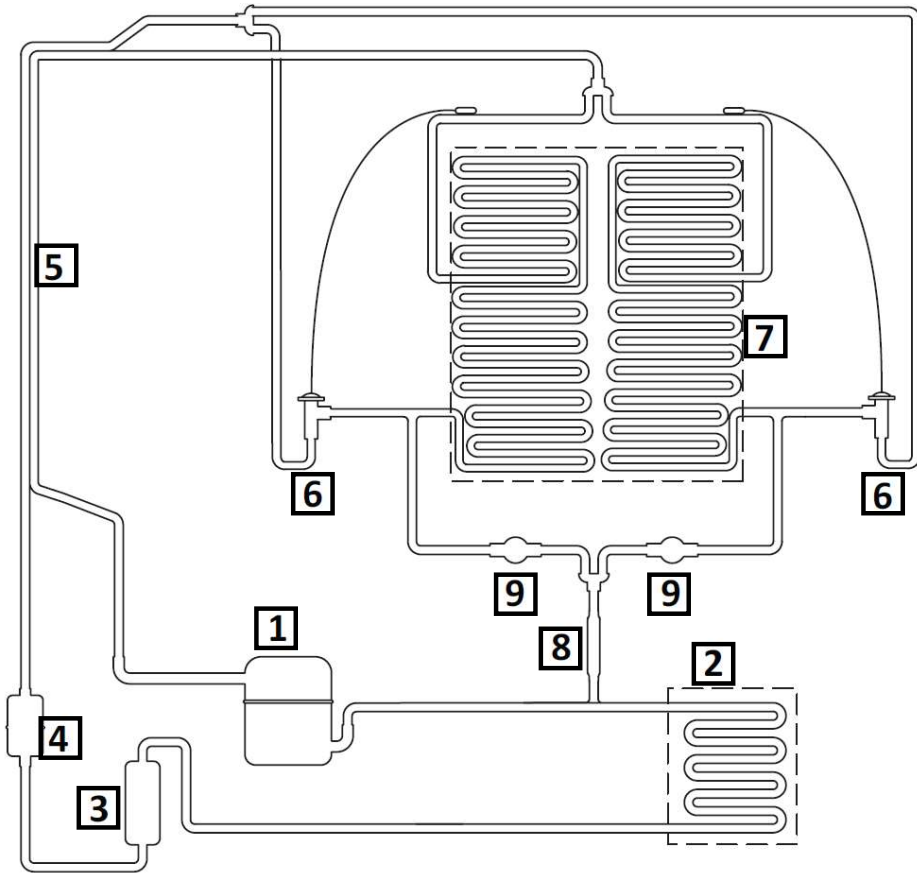

Number	Component
1	Compressor
2	Condenser
3	None
4	Liquid Line Filter Dryer
5	Heat Exchanger
6	TXV
7	Evaporator
8	Strainer
9	Harvest Solenoid Valve

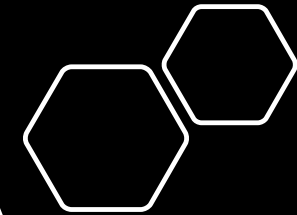

IM-Series  
Tubing Schematic



# Tubing Schematic

IM-1700/2000 Remote Air Cooled

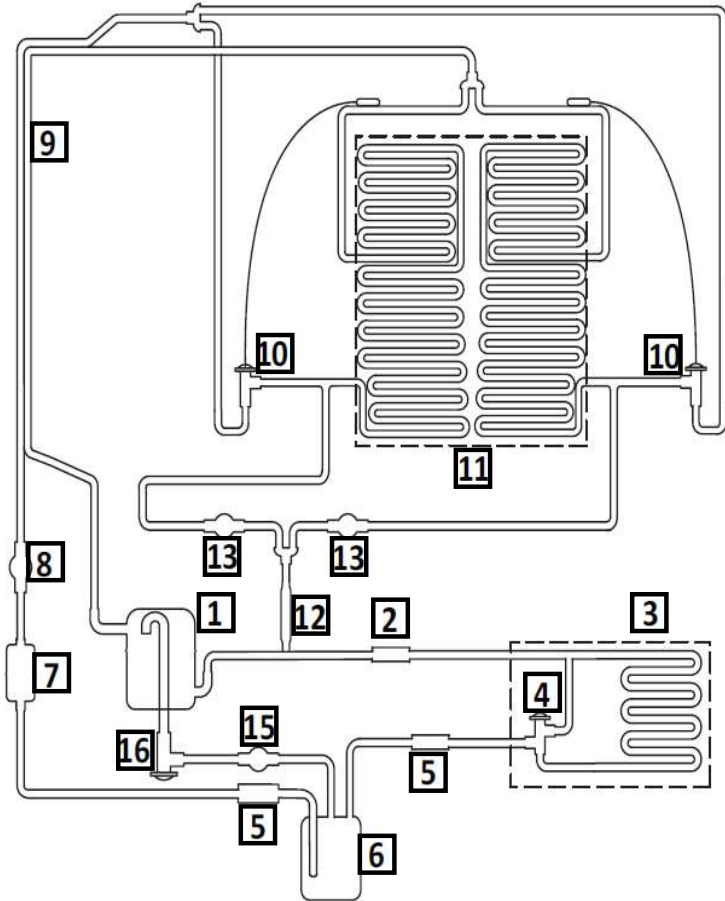

Number	Component
1	Compressor
2	Discharge Check Valve
3	Condenser
4	Head Pressure Control Valve
5	Liquid Line Filter Dryer
6	Receiver
7	Liquid Line Filter Dryer
8	Liquid Line Solenoid Valve
9	Heat Exchanger
10	TXV
11	Evaporator
12	Strainer
13	Harvest Solenoid Valve
15	Harvest Pressure Solenoid Valve
16	Harvest Pressure Regulating Valve

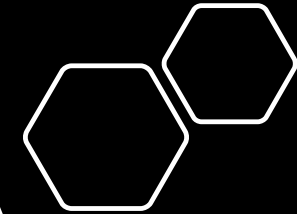

IM-Series  
Tubing Schematic

# Part List

IM-1700/2000 common use parts

[ OUT CASE ASSY ]

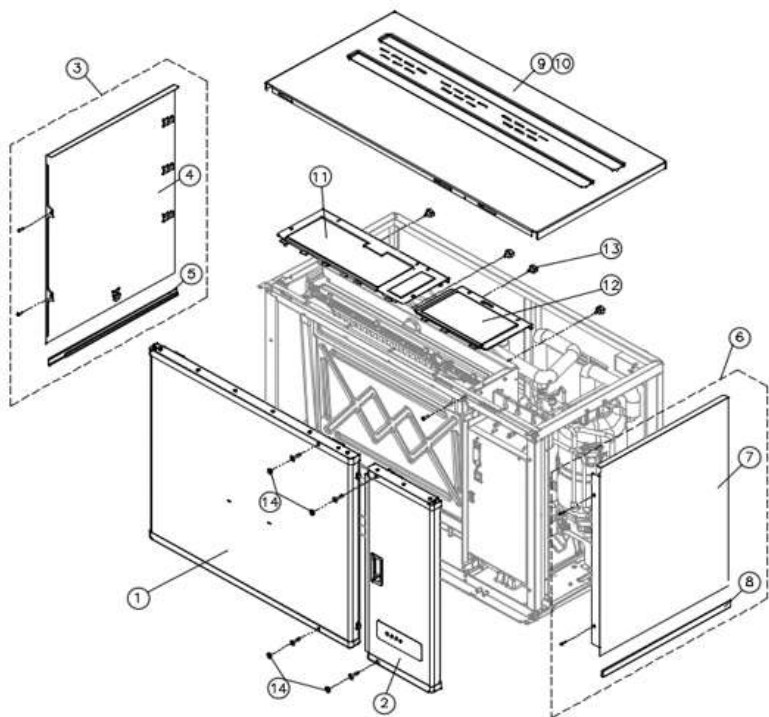

NO	ITEMS	CODE	EXW USD	QTY
1	FRONT PANEL(L) T-ASSY(48")	422003800		1
2	FRONT PANEL(R) T-ASSY(48")	422003900		1
3	LEFT SIDE PANEL ASSY	420049300		1
4	LEFT SIDE W-PANEL	349098900		1
5	SIDE PANEL B-ENDCAP(L)	348010200		1
6	RIGHT SIDE PANEL ASSY(48")	420053100		1
7	RIGHT SIDE W-PANEL	349109600		1
8	SIDE PANEL B-ENDCAP(R)	348010310		1
9	TOP COVER(48")	317224100		1
10	FOAM PE(TOP SPACE)	306049600		1
11	EVAP TOP COVER ASSY	427059100		1
12	EVAP TOP COVER ASSY®	427059110		1
13	HAND SCREW	210804502		4
14	CAP SILICON	319011120		4
15				
16				
17				
18				
19				
20				
21				
22				
23				
24				
25				
26				
27				
28				
29				
30				
31				
32				
33				
34				
35				

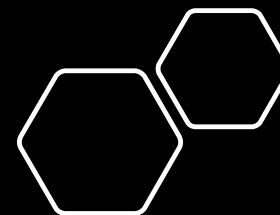

IM-Series  
Part List

# Part List

IM-1700/2000 common use parts

[ FRONT PANEL ASSY(L) ]

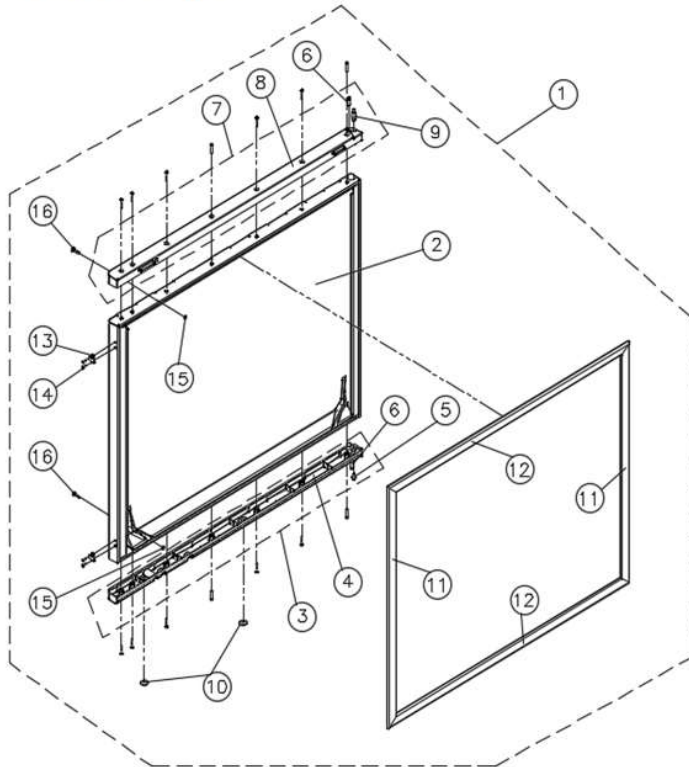

NO	ITEMS	CODE	EXW USD	QTY
1	FRONT PANEL(L) T-ASS'Y(48")	422003800		1
2	FRONT PANEL FOAM ASS'Y	422004200		1
3	F-BOTTOM CAP(L) ASSY(48")	432052500		1
4	BOTTOM END CAP-L(48")	341016300		1
5	SHAFT HINGE	321005000		1
6	PIN-PUSH ASS'Y	314045500		2
7	F-TOP CAP(L) ASSY(48")	432052600		1
8	TOP END CAP-L(48")	341016200		1
9	PIN-PUSH ASS'Y(LONG)	314045510		1
10	CAP SILICON	319011120		2
11	F-PANEL GASKET(TOP/LOW)	656004500		2
12	F-PANEL GASKET(TOP/LOW)	656004530		2
13	KEEPER	631000600		2
14	MACHINE SCREW(FLAT HEAD M3x10)	MFCX0620R		4
15	O-RING(AN105-φ2.62x IDφ3.63)	303036600		2
16	COVER SCREW(M5xL20)	210818600		2
17				
18				
19				
20				
21				
22				
23				
24				
25				
26				
27				
28				
29				
30				
31				
32				
33				
34				
35				

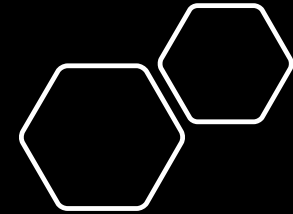

IM-Series  
Part List

# Part List

IM-1700/2000 common use parts

[ FRONT PANEL ASSY(R) ]

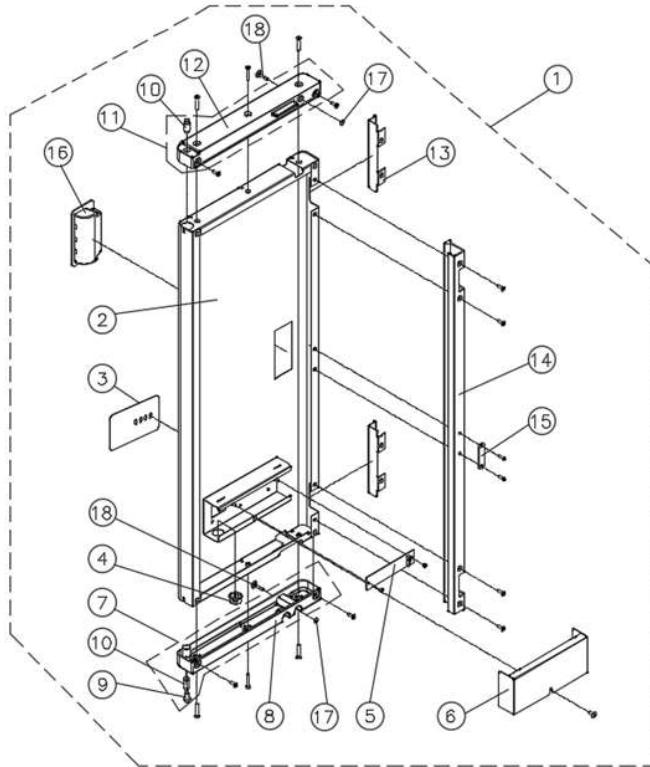

NO	ITEMS	CODE	EXW USD	QTY
1	FRONT PANEL(R) T-ASS'Y(48")	422003900		1
2	FRONT PANEL(R) W-ASS'Y(48")	420052800		1
3	FRONT DISPLAY	440033820		1
4	GROMMET BUSHING	232003600		1
5	DISPLAY PCB	367013000		1
6	COVER DISPLAY-PCB	317224300		1
7	F-BOTTOM CAP(R) ASSY(48")	432052700		1
8	BOTTOM END CAP-R(48")	341016500		1
9	SHAFT HINGE	321005000		1
10	PIN-PUSH ASS'Y	314045500		2
11	F-TOP CAP(R) ASSY(48")	432052800		1
12	TOP END CAP-R(48")	341016400		1
13	F-DOOR REINFORCE	301218800		2
14	GAP FRAME(DOOR)(후가공)	339018510		1
15	LOCKING MAGNET PLATE	322006010		1
16	EMBEDDED PULL	319010800		1
17	O-RING(AN105-φ2.62x IDφ3.63)	303036600		2
18	COVER SCREW(M5xL20)	210818600		2
19				
20				
21				
22				
23				
24				
25				
26				
27				
28				
29				
30				
31				
32				
33				
34				
35				

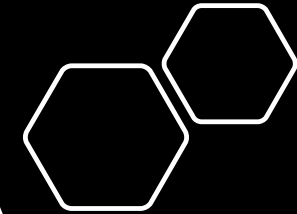

IM-Series  
Part List

# Part List

IM-1700/2000 common use parts

[ EVA S-PANEL ASSY(R) ]

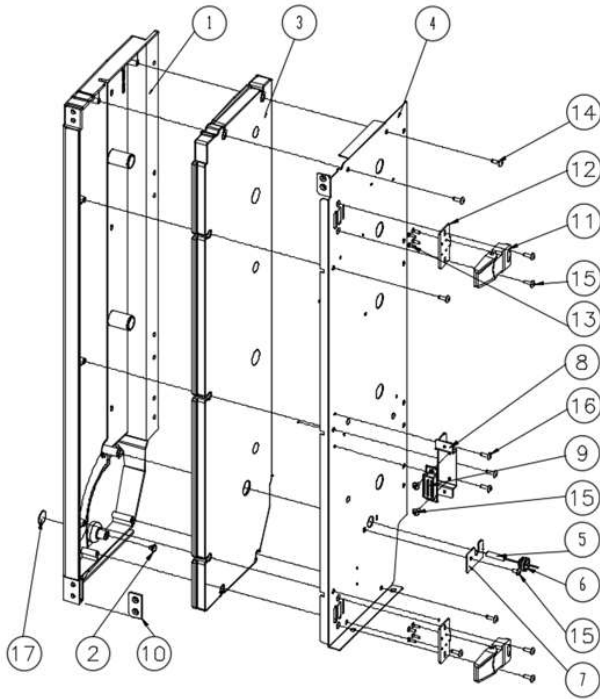

NO	ITEMS	CODE	EXW USD	QTY
	EVA S-PANEL ASSY-R	420053000		1
1	EVA S-PANEL(R)	339015901		1
2	HOLE-CAP	303041600		1
3	EPS SIDE INSULATION(R)	329037501		1
4	EVA S-PANEL COVER(R,48")	317224500		1
5	ASSY SENSOR MAGNET	701002000		1
6	SENSOR CAP	319009300		1
7	COVER BRACKET (M-SENSOR)	301169400		1
8	BASE BRACKET(MAGNET)	301219600		1
9	LOCKING MAGNET	322006000		1
10	PANEL INSERT-BRACKET(R)	301170201		1
11	DRAW LATCH	631000210		2
12	LATCH BASE BRACKET	301219200		2
13	MACHINE SCREW(FLAT M3x10)	MFCX0620R		8
14	TAPPING SCREW(TRUSS M4x10)	TTCQ0820R		7
15	MACHINE SCREW(TRUSS M4x10)	MTCX0820R		7
16	TAP TIGHT SCREW(TRUSS M4x8)	HTCX0820T		2
17	CIRCLE ADHESIVE STICKER	226003710		1
18				
19				
20				
21				
22				
23				
24				
25				
26				
27				
28				
29				
30				
31				
32				
33				
34				

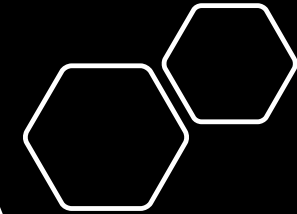

IM-Series  
Part List





# Part List

IM-1700/2000 common use parts

[ WATER IN/OUT ASSY ]

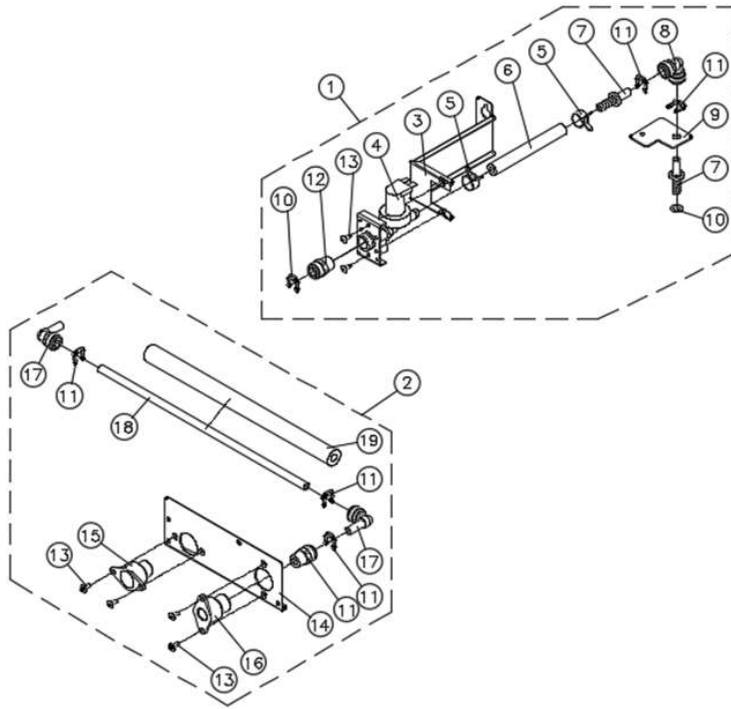

NO	ITEMS	CODE	EXW USD	Q.TY
1	WATER INLET VALVE ASSY(48")	469003900		1
2	WATER INLET HOSE ASSY(48")	469002840		1
3	WATER IN-VALVE BRACKET(48")	301219700		1
4	WATER INLET VALVE(220V 50/60Hz)	340027520		1
5	BAND SPRING 17	203003200		2
6	SPRAY HOSE	229037900		0.12
7	TUBE TO HOSE STEM	398014200		2
8	EQUAL ELBOW	398012000		1
9	WATER INLET FIX BRACKET	301219800		1
10	O-RING(AN110)	303036400		1
11	LOCKING CLIP(3/8)	224002000		3
12	STRAIGHT ADAPTOR(3/8)	398016500		2
13	MACHINE SCREW(M4x8)	MTCX0816R		6
14	WATER IN-OUT BRACKET	301171010		1
15	SOCKET(3/4" NPT, OD Φ20)	215013400		1
16	SOCKET(3/8" NPT-3/8" NPT)	215018700		1
17	STEM ELBOW	398013801		2
18	PE TUBE (OD 3/8)	229013500		0.35
19	PIPE INSULATION(ID 10, t5)	306009000		0.35
20				
21				
22				
23				
24				
25				
26				
27				
28				
29				
30				
31				
32				
33				
34				
35				

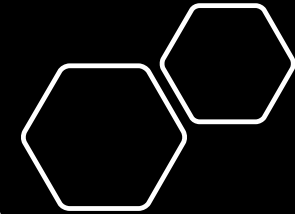

IM-Series  
Part List





# Part List

IM-1700/2000 common use parts

## [WATER THROUGH & PUMP ASSY ]

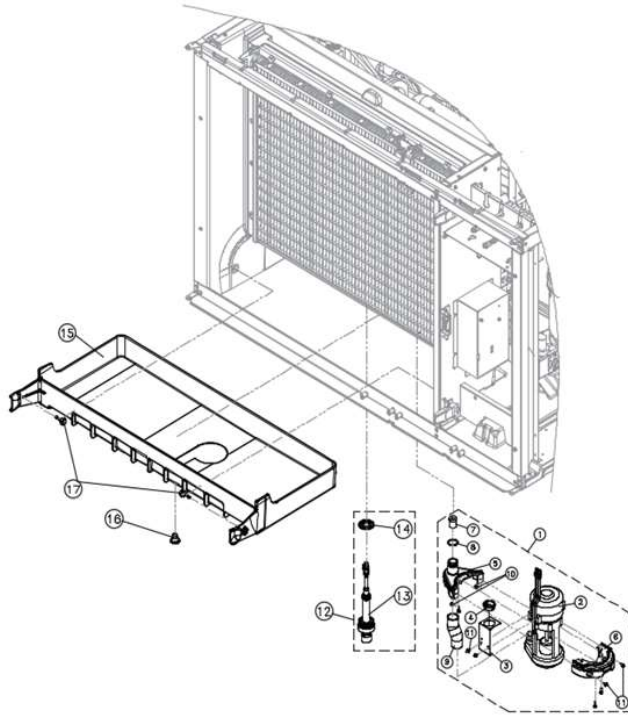

NO	ITEMS	CODE	EXW USD	Q.TY
1	WATER PUMP TOTAL ASSY(ORIFICE Φ8)	406023060		1
2	PUMP MOTOR/SP-B6HLEJ26	353020401		1
3	HARNES BRACKET(W-PUMP)	301170901		1
4	GROMMET BUSHING	232003500		1
5	WATER PUMP HOLDER(L)	339013600		1
6	WATER PUMP HOLDER(R)	339013700		1
7	PACKING ORIFICE(ORIFICE Φ15.5)	319010510		1
8	O-RING(AN118)	303036200		1
9	CONNECTING HOSE(PUMP)	229031700		1
10	CAP NUT(M4, 전핵연마)	210806000P		2
11	MACHINE SCREW(TRUSS M4x10)	MTCX0816R		4
12	WATER LEVEL PROBE ASS'Y	701004000		1
13	WATER LEVEL PROBE CAP ASS'Y	701003800		1
14	W. LEVLE RUBBER-HOLDER	303036100		1
15	WATER TROUGH(48")	339018600		1
16	PACKING DOWN	303022000		1
17	KNOB SCREW(M5)	210823210		2
18				
19				
20				
21				
22				
23				
24				
25				
26				
27				
28				
29				
30				
31				
32				
33				
34				
35				

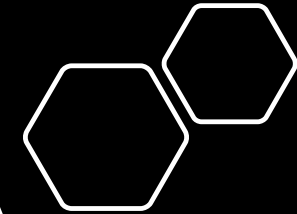

IM-Series  
Part List

# Part List

IM-1700/2000 Remote Air Cooled

[FRAME&ACC. PARTS ]

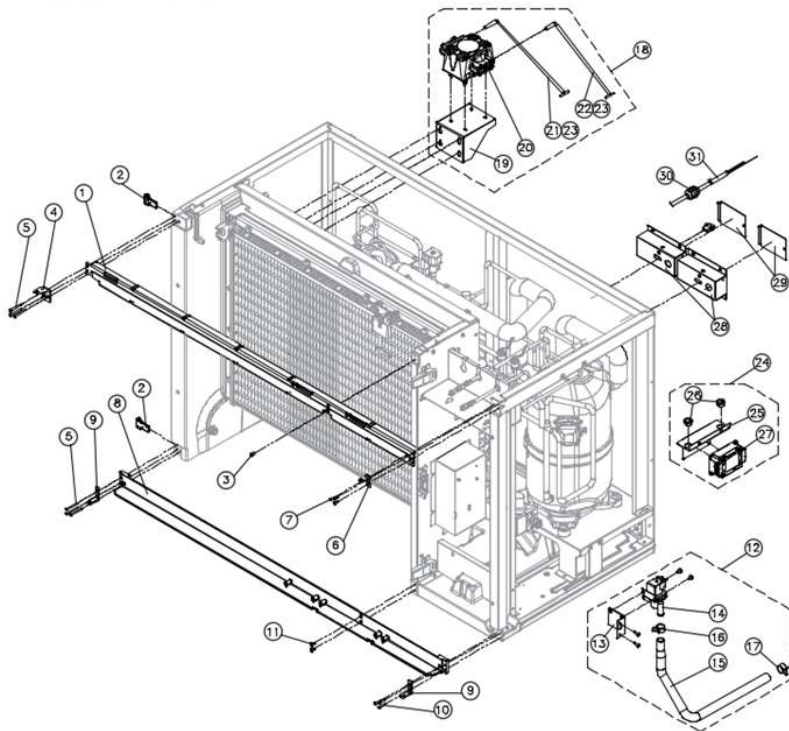

NO	ITEMS	CODE	EXW USD	Q'TY
1	FRONT TOP SUPPORT(48")	341016700		1
2	HINGE SUPPORT	341012300		2
3	MACHINE SCREW(FLAT M5x12)	MFCX1022R		1
4	TOP HINGE BRACKET-L(전해연마)	321008610		1
5	TAPPING SCREW(FLAT M4x40)	TFCQ0841R		6
6	HINGE BRACKET(전해연마)	321005120		1
7	MACHINE SCREW(FLAT M4x10)	MFCX0820R		3
8	FRONT BOTTOM-FRAME(48")	341016600		1
9	HINGE BRACKET DOWN(전해연마)	321005220		2
10	MACHINE SCREW(FLAT M4x25)	MFCX0832R		3
11	MACHINE SCREW(FLAT M5x15)	MFCX1025R		2
12	WATER DRAIN VALVE ASS'Y(48", 220V)	469004000		1
13	BRACKET DRAIN VALVE (DELTROL)	301169600		1
14	WATER VALVE (DELTROL AC220V)	340025800		1
15	DRAIN VALVE TO DRAIN-DELTROL (PVC)	229032100		1
16	BAND SPRING 20	203004200		1
17	BAND SPRING 21	203003300		1
18	AIR PUMP CIRCUIT ASS'Y	469004100		1
19	SUPPORT AIR-PUMP	318042300		1
20	AIR PUMP MOTOR	353036300		1
21	AIR HOSE ASS'Y(PUMP-L)	468020800		1
22	AIR HOSE ASS'Y(PUMP-R)	468020810		1
23	CABLE TIE(100mm)	202000500		4
24	NOISE FILTER SUB ASS'Y	722018200		1
25	NOISE FILTER BRACKET(범함+운영)	301171111		1
26	GROMMET BUSHING	232003600		2
27	NOISE FILTER	500002000		1
28	JUNCTION BOX(REMOTE)	374148110		2
29	JUNCTION BOX COVER	317197900		2
30	BUSHING(HOLEφ25 IDφ18*ODφ30)	232000400		1
31	POWER CORD ASSY			1
32				
33				
34				
35				

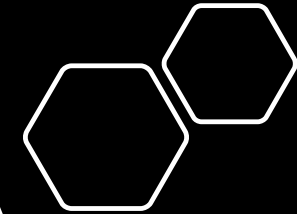

IM-Series  
Part List

# Part List

IM-1700/2000 Remote Air Cooled

[ COMP & RECEIVER PARTS ]

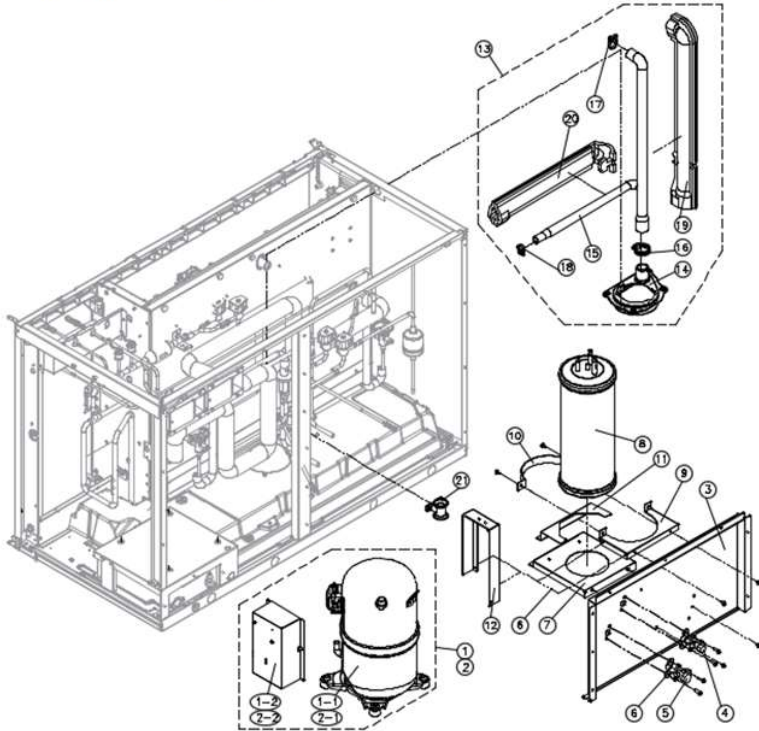

NO	ITEMS	CODE	EXW USD	Q'TY
1	COMP. ASS'Y(for IM-2000~)	-		-
1-1	COMP/H82J443ABCA	394024400		1
1-2	CSR BOX ASS'Y(H82J443ABCA)	426074600		1
2	COMP. ASS'Y(for IM-1700~)	-		-
2-1	COMP/H82J353ABCA	394024500		1
2-2	CSR BOX ASS'Y(H82J353ABCA)	426074610		1
3	BACK PLATE(COND IN-OUT,48")	349110600		1
4	SUCTION SVC VALVE ASS'Y	429006100		1
5	DISCHARGE SERVICE VALVE ASSY	429006000		1
6	BUSHING(ODΦ20)	232006900		4
7	BASE LIQUID RECEIVER	301220000		1
8	RECEIVER	433046000		1
9	RECEIVER FIX BRACKET(48")	301206210		1
10	RECEIVER COVER BRACKET	301206300		1
11	RECEIVE BASE FIX BKT	301224300		1
12	SUPPORT BRACKET(SOL V/V)	301220100		1
13	WATER PUMP MOUNT ASSY (48")	463000710		1
14	WATER PUMP MOUNT	339013500		1
15	WATER CIRCU. & DRAIN TUBE(48")	229036700		1
16	BAND HOSE 40	203001400		1
17	CLAMP HOSE(SNP28 28-Φ33,PA66GF13 黒H)	229026600		1
18	BAND SPRING 17	203003200		1
19	FOAM PUMP TO DISTRIBUTOR(500)	306042500		1
20	FOAM PUMP TO DRAIN(48")	306042110		1
21	WATER LEVEL PROBE-HOLDER	339014100		1
22				
23				
24				
25				
26				
27				
28				
29				
30				

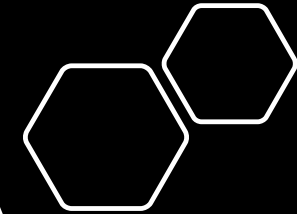

IM-Series  
Part List

# Part List

IM-1700/2000 Remote Air Cooled

[ REFRIGERATION PARTS ]

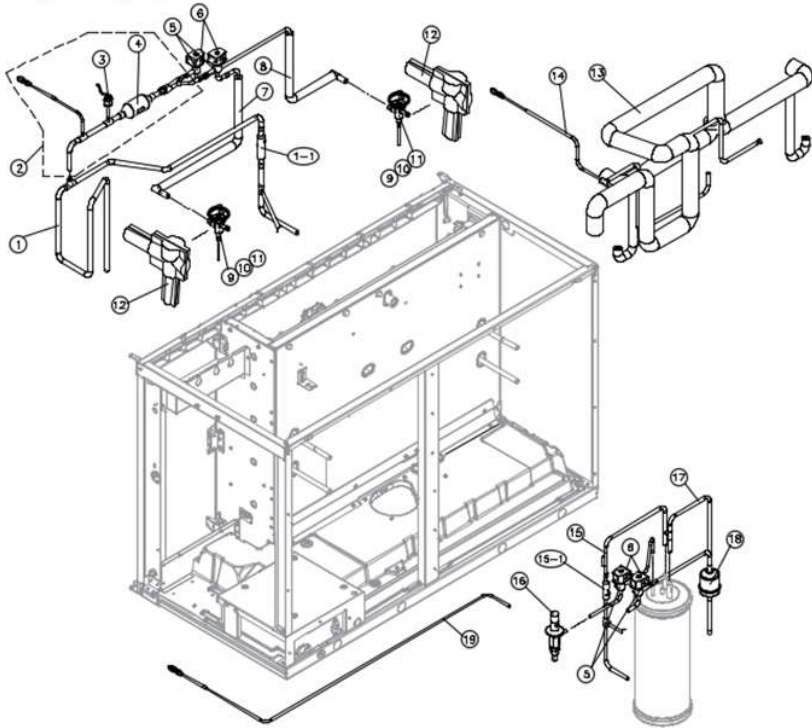

NO	ITEMS	CODE	EXW USD	Q'TY
1	DISCHARGE PIPE ASS'Y(REMOTE)	433050700		1
1-1	CHECK VALVE(NRV 125)	340032700		1
2	HOT GAS PIPE ASS'Y(48";REMOTE)	433047100		1
3	HIGH PRESSURE S/W ASS'Y	429010600		1
4	STRAINER	605002200		1
5	SOLENOID VALVE BODY	340028200		4
6	ASSY SOLENOID VALVE COIL (220V/FDF8A17)	429007000		4
7	HOT SOL TO TXV(R) PIPE	325163600		1
8	HOT SOL TO TXV(L) PIPE	325163700		1
9	EXPANSION VALVE-(Inlet Flare TYPE)	340033000		2
10	ORIFICE(#1)	340033100		2
11	EXPANSION IN NUT ASSY	325161300		2
12	FOAM PE (EXPANSION)	306016700		2
13	HEAT EXCHANGE PIPE ASS'Y(48";REMOTE)	433047800		1
14	HPR-VALVE TO COMP PIPE(48";REMOTE)	325164700		1
15	RECEIVER INLET-CHECK V ASS'Y	433050600		1
15-1	CHECK VALVE(NRV 105)	340032600		1
16	Harvest Pressure Regulating Valve	340032900		1
17	RECEIVER OUTLET PIPE	325160500		1
18	FILTER DRYER	372002900		1
19	RECEIVER CHARGE NIPPLE(48")	325164000		1
20				
21				
22				
23				
24				
25				
26				
27				
28				
29				
30				
31				
32				

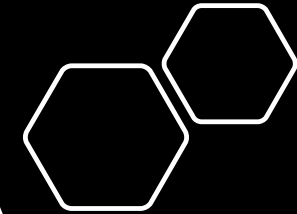

IM-Series  
Part List

# Part List

IM-1700/2000 Remote Air Cooled

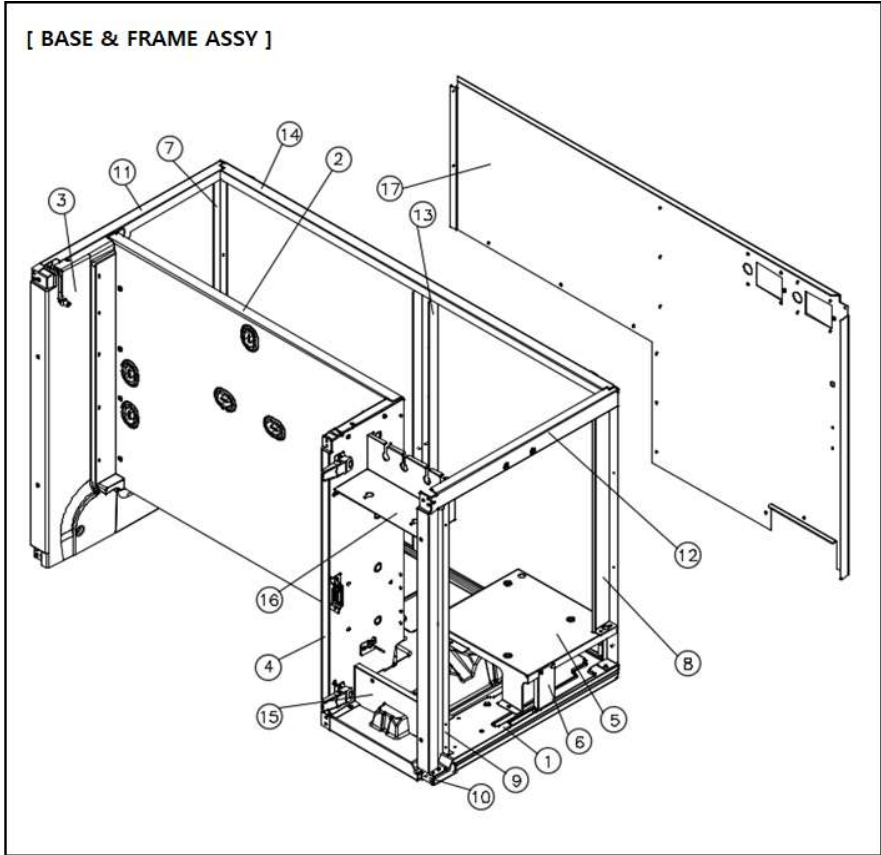

NO	ITEMS	CODE	EXW USD	Q.TY
1	BASE PLATE FOAM ASSY(48")	483032800		1
2	EVA BACK PANEL ASS'Y(48")	422004000		1
3	EVA S-PANEL ASS'Y(L)	420049700		1
4	EVA S-PANEL ASS'Y(R)	420053000		1
5	SUPPORT COMP(48")	320594200		1
6	SUPPORT COMP. BRACKET	320593800		1
7	SIDE REAR FRAME(L)	348011300		1
8	SIDE REAR FRAME-R(48")	348021700		1
9	FRONT SIDE FRAME-R(48")	348021000		1
10	HINGE BASE BRACKET	301218900		1
11	SIDE TOP FRAME(L)	348010700		1
12	SIDE TOP FRAME-R(48")	348021100		1
13	REAR MIDDLE FRAME(48")	348021800		1
14	REAR TOP FRAME(48")	348021500		1
15	CONTROL BOTTOM-REINFORCE	348021600		1
16	CONTROL TOP-REINFORCE	348021400		1
17	BACK PANEL(REMOTE, 48")	349109100		1
18				
19				
20				
21				
22				
23				
24				
25				
26				
27				
28				
29				
30				
31				
32				
33				
34				
35				

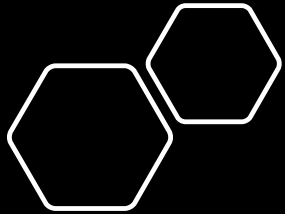

IM-Series  
Part List













# Part List

IM-1700/2000 Air & Water Cooled

[FRAME&ACC. PARTS ]

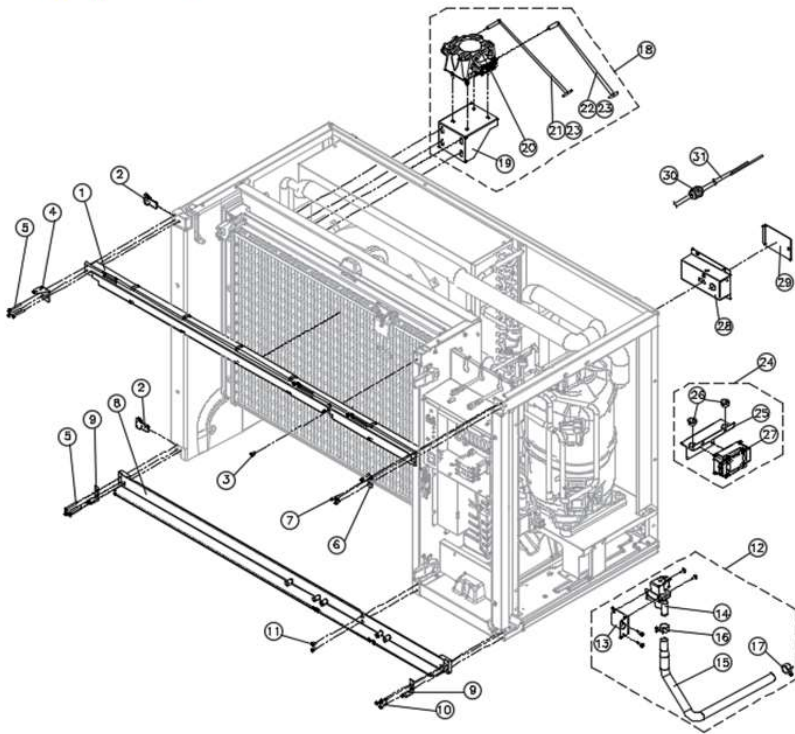

NO	ITEMS	CODE	EXW USD	Q'TY
1	FRONT TOP SUPPORT(48")	341016700		1
2	HINGE SUPPORT	341012300		2
3	MACHINE SCREW(FLAT M5x12)	MFCX1022R		1
4	TOP HINGE BRACKET-L(전해연마)	321008610		1
5	TAPPING SCREW(FLAT M4x40)	TFCQ0841R		6
6	HINGE BRACKET(전해연마)	321005120		1
7	MACHINE SCREW(FLAT M4x10)	MFCX0820R		3
8	FRONT BOTTOM-FRAME(48")	341016600		1
9	HINGE BRACKET DOWN(전해연마)	321005220		2
10	MACHINE SCREW(FLAT M4x25)	MFCX0832R		3
11	MACHINE SCREW(FLAT M5x15)	MFCX1025R		2
12	WATER DRAIN VALVE ASS'Y(48", 220V)	469004000		1
13	BRACKET DRAIN VALVE (DELTROL)	301169600		1
14	WATER VALVE (DELTROL AC220V)	340025800		1
15	DRAIN VALVE TO DRAIN-DELTROL (PVC)	229032100		1
16	BAND SPRING 20	203004200		1
17	BAND SPRING 21	203003300		1
18	AIR PUMP CIRCUIT ASS'Y	469004100		1
19	SUPPORT AIR-PUMP	318042300		1
20	AIR PUMP MOTOR	353036300		1
21	AIR HOSE ASS'Y(PUMP-L)	468020800		1
22	AIR HOSE ASS'Y(PUMP-R)	468020810		1
23	CABLE TIE(100mm)	202000500		4
24	NOISE FILTER SUB ASS'Y	722018200		1
25	NOISE FILTER BRACKET(별함+윤영)	301171111		1
26	GROMMET BUSHING	232003600		2
27	NOISE FILTER	500002000		1
28	JUNCTION BOX(REMOTE)	374148110		1
29	JUNCTION BOX COVER	317197900		1
30	BUSHING(HOLEφ25 IDφ18*ODφ30)	232000400		1
31	POWER CORD ASSY			1
32				
33				
34				
35				

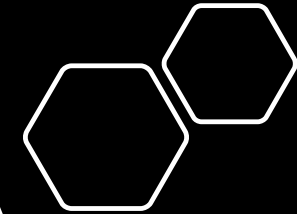

IM-Series  
Part List

# Part List

IM-1700/2000 Air Cooled

[ COMP & CONDENSER PARTS ]

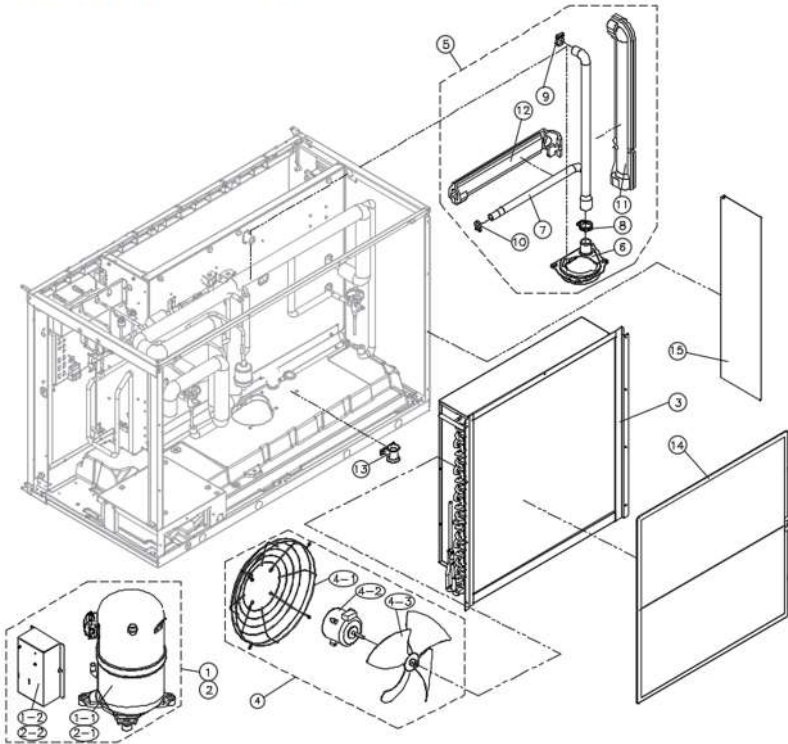

NO	ITEMS	CODE	EXW USD	Q.TY
1	COMP. ASS'Y(for IM-2000~)	-		-
1-1	COMP/H82J443ABCA	394024400		1
1-2	CSR BOX ASS'Y(H82J443ABCA)	426074600		1
2	COMP. ASS'Y(for IM-1700~)	-		-
2-1	COMP/H82J353ABCA	394024500		1
2-2	CSR BOX ASS'Y(H82J353ABCA)	426074610		1
3	CONDENSER ASSY	411036100		1
4	FAN MOTOR ASSY	353036200		1
5	WATER PUMP MOUNT ASSY (48")	463000710		1
6	WATER PUMP MOUNT	339013500		1
7	WATER CIRCU. & DRAIN TUBE(48")	229036700		1
8	BAND HOSE 40	203001400		1
9	CLAMP HOSE(S/NP28 28~Φ13,PA66GF13 青塩)	229026600		1
10	BAND SPRING 17	203003200		1
11	FOAM PUMP TO DISTRIBUTOR(500)	306042500		1
12	FOAM PUMP TO DRAIN(48")	306042110		1
13	WATER LEVEL PROBE-HOLDER	339014100		1
14	FILTER CONDENSER(W673 x H710)	640008810		1
15	AIR PROTECTOR	339016000		1
16				
17				
18				
19				
20				
21				
22				
23				
24				
25				
26				
27				
28				
29				
30				

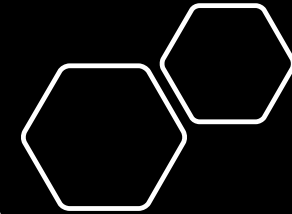

IM-Series  
Part List

# Part List

IM-1700/2000 Air Cooled

[ REFRIGERATION PARTS ]

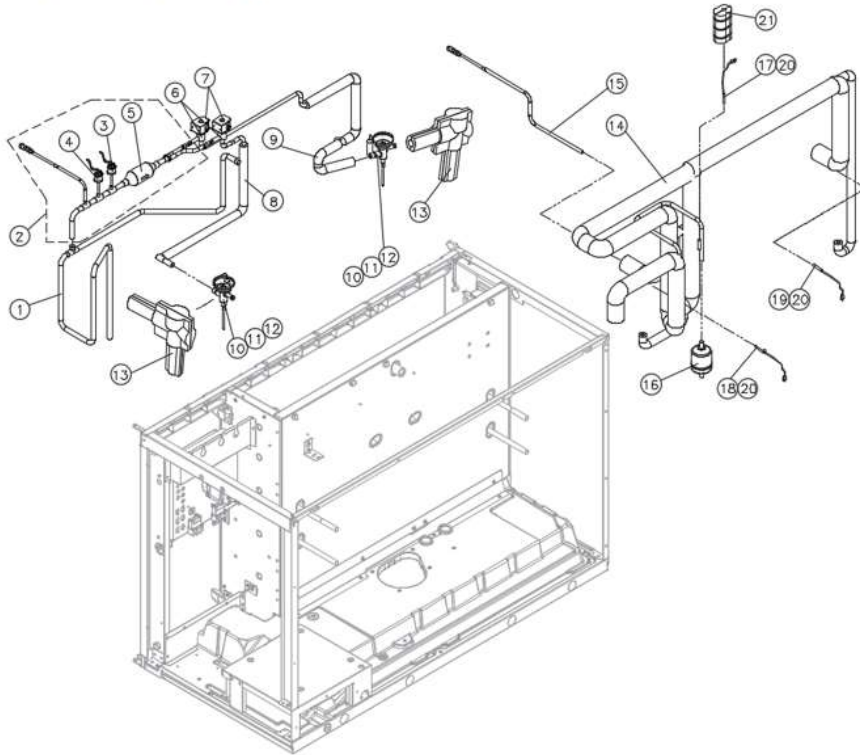

NO	ITEMS	CODE	EXW USD	Q'TY
1	DISCHARGE PIPE ASS'Y(48",AIR)	433047900		1
2	HOT GAS PIPE ASS'Y(48",A/E)	433047120		1
3	HIGH PRESSURE S/W ASS'Y	429010600		1
4	HIGH PRESSURE S/W ASS'Y(FAN)	429010700		1
5	STRAINER	605002200		1
6	SOLENOID VALVE BODY	340028200		2
7	ASSY SOLENOID VALVE COIL (220V)	429007000		2
8	HOT SOL TO TXV(R) PIPE	325163600		1
9	HOT SOL TO TXV(L) PIPE(AIR)	325166200		1
10	EXPANSION VALVE-(Inlet Flare TYPE)	340033000		2
11	ORIFICE(#2)	340033200		2
12	EXPANSION IN NUT ASSY	325161300		2
13	FOAM PE (EXPANSION)	306016700		2
14	HEAT EXCHANGE PIPE ASS'Y(48",AIR)	433048000		1
15	SUCTION CHARGE NIPPLE(48")	325164600		1
16	FILTER DRYER	372002900		1
17	EVA SENSOR SB(BLACK)	655008200		1
18	EVA SENSOR SB(BLUE)	655008210		1
19	EVA SENSOR SB(YELLOW)	655008220		1
20	SENSOR CLIP	224002400		1
21	FOAM SENSOR INSULATION	306043300		1
22				
23				
24				
25				
26				
27				
28				
29				
30				
31				
32				
33				
34				

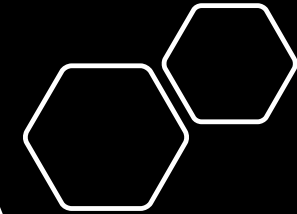

IM-Series  
Part List

# Part List

IM-1700/2000 Air Cooled

[ BASE & FRAME ASSY ]

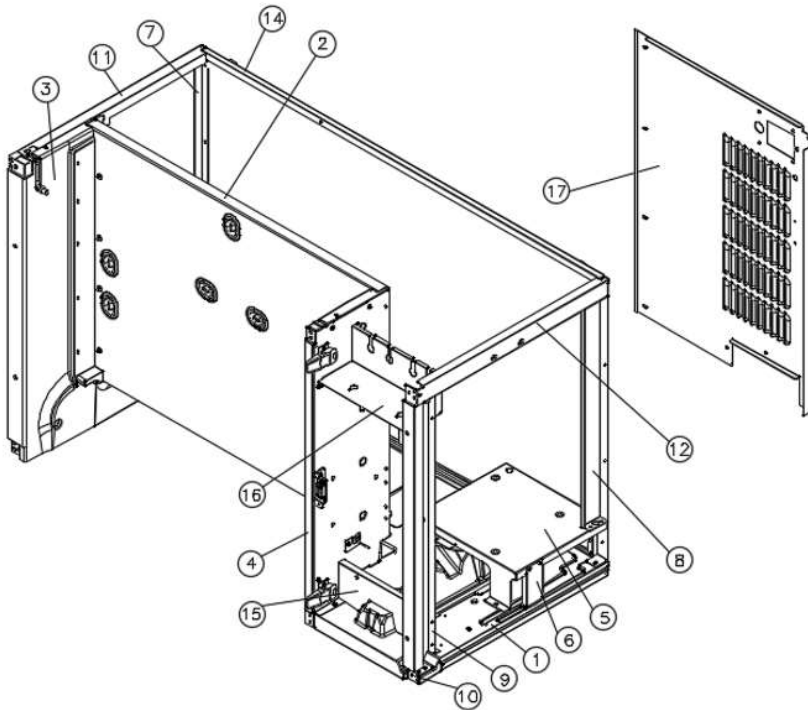

NO	ITEMS	CODE	EXW USD	QTY
1	BASE PLATE FOAM ASSY(48")	483032800		1
2	EVA. BACK PANEL ASS'Y(48")	422004000		1
3	EVA S-PANEL ASS'Y(L)	420049700		1
4	EVA S-PANEL ASS'Y(R)	420053000		1
5	SUPPORT COMP(48")	320594200		1
6	SUPPORT COMP. BRACKET	320593800		1
7	SIDE REAR FRAME(L)	348011300		1
8	SIDE REAR FRAME-R(48")	348021700		1
9	FRONT SIDE FRAME-R(48")	348021000		1
10	HINGE BASE BRACKET	301218900		1
11	SIDE TOP FRAME(L)	348010700		1
12	SIDE TOP FRAME-R(48")	348021100		1
13	-	-		-
14	REAR TOP FRAME(48")	348021500		1
15	CONTROL BOTTOM-REINFORCE	348021600		1
16	CONTROL TOP-REINFORCE	348021400		1
17	BACK PANEL(48",AIR)	349110200		1
18				
19				
20				
21				
22				
23				
24				
25				
26				
27				
28				
29				
30				
31				
32				
33				
34				
35				

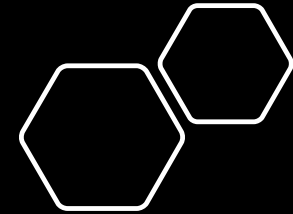

IM-Series  
Part List



# Part List

## IM-1700 Water Cooled

### [ COMP & CONDENSER PARTS ]

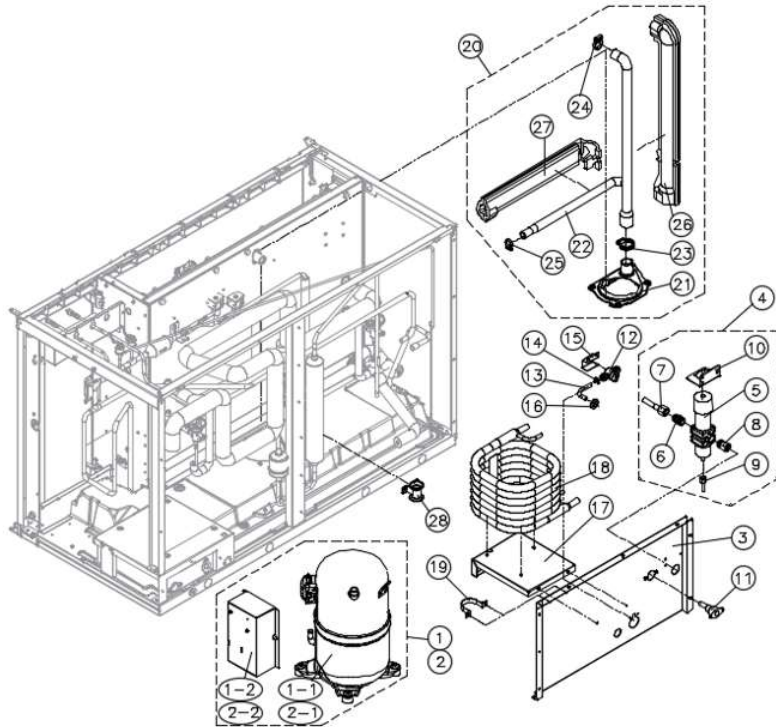

NO	ITEMS	CODE	EXW USD	Q'TY
1	COMP. ASS'Y(for IM-2000~)	-	-	-
1-1	COMP/H82J443ABCA	394024400	-	-
1-2	CSR BOX ASS'Y(H82J443ABCA)	426074600	-	-
2	COMP. ASS'Y(for IM-1700~)	-	-	-
2-1	COMP/H82J353ABCA	394024500	-	1
2-2	CSR BOX ASS'Y(H82J353ABCA)	426074610	-	1
3	BACK PLATE(COND IN-OUT, EX)	349109200	-	1
4	WATER ADJ VALVE ASSY(48",DENFOSS)	<b>408001410</b>	-	1
5	WATER ADJ VALVE(48"-DENFOSS)	340033300	-	1
6	FLARE NIPPLE 1/2"	215018100	-	1
7	FLARE SLEEVE ASSY	407024700	-	1
8	ADAPTER-ADJ V/V IN(DANFOSS)	<b>364004800</b>	-	1
9	ADJ ADAPTOR (PRESSURE PART)	429010100	-	1
10	WATER ADJ BRACKET(Danfoss)	301187700	-	1
11	SOCKET WELD ASSY(3/4",NPT)	<b>215015510</b>	-	1
12	SPEEDFIT TO SPEEDFIT CONNECTOR	398012400	-	-
13	WATER DRAIN PIPE	325081700	-	-
14	LOCKING CLIP 3/8"	224002000	-	-
15	BRACKET HAND VALVE	301093710	-	-
16	[사]BUSHING(PIPE)	232004900	-	-
17	SUPPORT CONDENSER(WATER1700)	<b>301221000</b>	-	1
18	DOUBLE WATER CONDENSER(6.5T)	<b>411033810</b>	-	1
19	BAND LIQUID RECEIVER	301221100	-	1
20	WATER PUMP MOUNT ASSY (48")	463000710	-	1
21	WATER PUMP MOUNT	339013500	-	1
22	WATER CIRCU. & DRAIN TUBE(48")	229036700	-	1
23	BAND HOSE 40	203001400	-	1
24	CLAMP HOSE(SNP28 28-φ33)	229026600	-	1
25	BAND SPRING 17	203003200	-	1
26	FOAM PUMP TO DISTRIBUTOR(500)	306042500	-	1
27	FOAM PUMP TO DRAIN(48")	306042110	-	1
28	WATER LEVEL PROBE-HOLDER	339014100	-	1
29				
30				

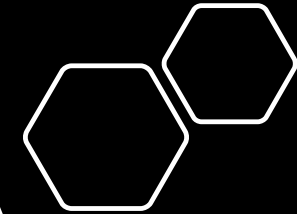

# Part List

## IM-2000 Water Cooled

### [ COMP & CONDENSER PARTS ]

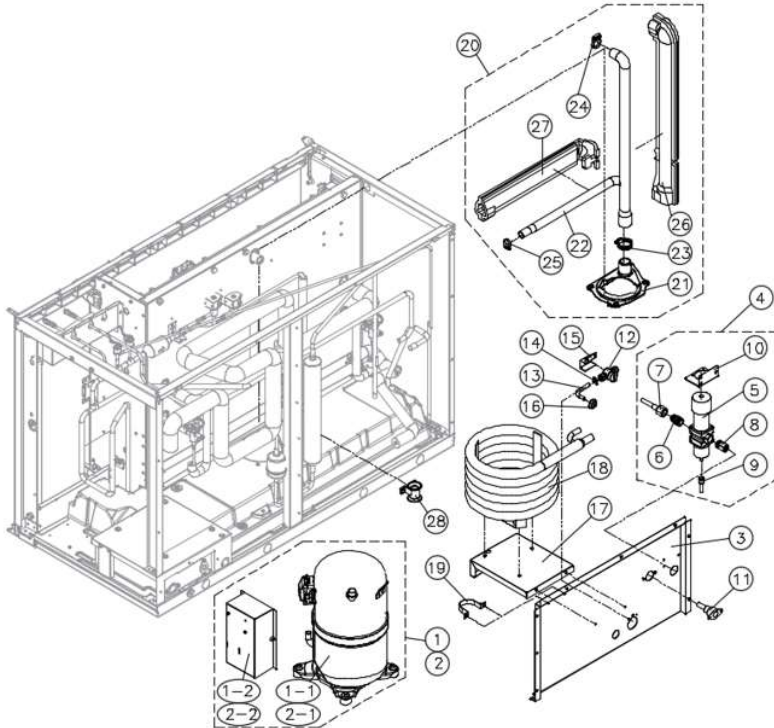

NO	ITEMS	CODE	EXW USD	Q.TY
1	COMP. ASS'Y(for IM-2000~)	-	-	-
1-1	COMP/H82J443ABCA	394024400	-	1
1-2	CSR BOX ASS'Y(H82J443ABCA)	426074600	-	1
2	COMP. ASS'Y(for IM-1700~)	-	-	-
2-1	COMP/H82J353ABCA	394024500	-	-
2-2	CSR BOX ASS'Y(H82J353ABCA)	426074610	-	-
3	BACK PLATE(COND IN-OUT, EX)	349109200	-	1
4	WATER ADJ VALVE ASSY(48",DENFOSS)	408001400	-	1
5	WATER ADJ VALVE(48"-DENFOSS)	340033300	-	1
6	FLARE NIPPLE 1/2"	215018100	-	1
7	FLARE SLEEVE ASSY	407024700	-	1
8	ADAPTER-ADJ V/V IN(DANFOSS)	364004810	-	1
9	ADJ ADAPTOR (PRESSURE PART)	429010100	-	1
10	WATER ADJ BRACKET(Danfoss)	301187700	-	1
11	SOCKET WELD ASSY(3/4",NPT)	215020800	-	1
12	SPEEDRIT TO SPEEDRIT CONNECTOR	398012400	-	-
13	WATER DRAIN PIPE	325081700	-	-
14	LOCKING CLIP 3/8"	224002000	-	-
15	BRACKET HAND VALVE	301093710	-	-
16	[사급]BUSHING(PIPE)	232004900	-	-
17	SUPPORT CONDENSER(WATER,2000)	301220900	-	1
18	DOUBLE WATER CONDENSER(S.5T)	411035900	-	1
19	BAND LIQUID RECEIVER	301221100	-	1
20	WATER PUMP MOUNT ASSY (48")	463000710	-	1
21	WATER PUMP MOUNT	339013500	-	1
22	WATER CIRCU. & DRAIN TUBE(48")	229036700	-	1
23	BAND HOSE 40	203001400	-	1
24	CLAMP HOSE(SNP28 28~φ33)	229026600	-	1
25	BAND SPRING 17	203003200	-	1
26	FOAM PUMP TO DISTRIBUTOR(S00)	306042500	-	1
27	FOAM PUMP TO DRAIN(48")	306042110	-	1
28	WATER LEVEL PROBE-HOLDER	339014100	-	1
29				
30				

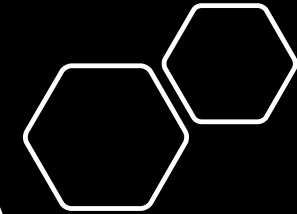

# Part List

## IM-1700 Water Cooled

### [ REFRIGERATION PARTS ]

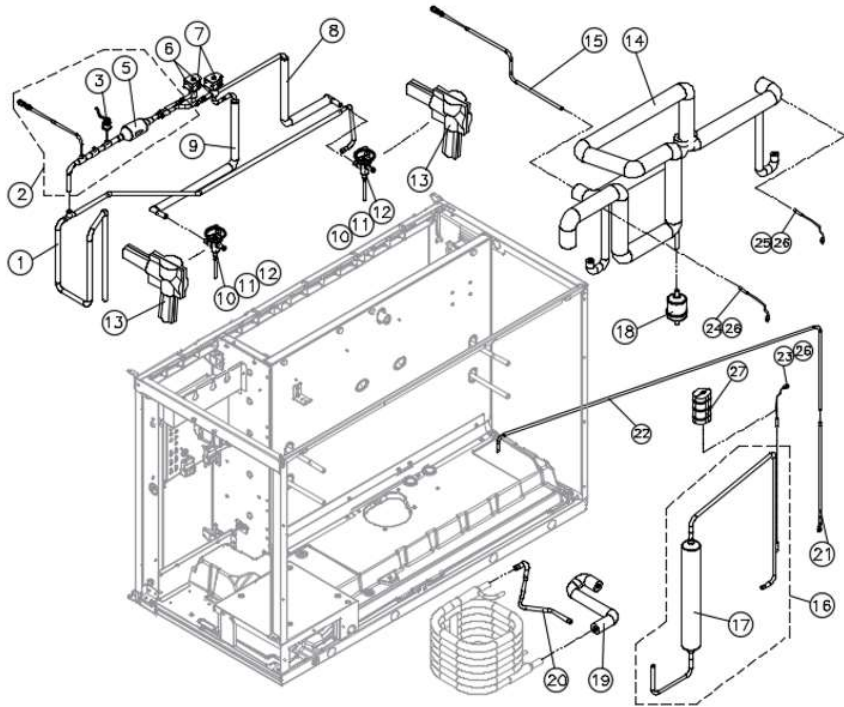

NO	ITEMS	CODE	EXW USD	Q'TY
1	DISCHARGE PIPE ASS'Y(WATER-2000)	433048400		1
2	HOT GAS PIPE ASS'Y(48")WATER)	433047110		1
3	HIGH PRESSURE S/W ASS'Y	429010600		1
4	HIGH PRESSURE S/W ASS'Y(FAN)	429010700		-
5	STRAINER	605002200		1
6	SOLENOID VALVE BODY	340028200		2
7	ASSY SOLENOID VALVE COIL (220V)	429007000		2
8	HOT SOL TO TXV(R) PIPE	325163600		1
9	HOT SOL TO TXV(L) PIPE	325163700		1
10	EXPANSION VALVE-(Inlet Flare TYPE)	340033000		2
11	ORIFICE(#1)	340033100		2
12	EXPANSION IN NUT ASSY	325161300		2
13	FOAM PE (EXPANSION)	306016700		2
14	HEAT EXCHANGE PIPE ASS'Y(WATER-2000)	433047700		1
15	SUCTION CHARGE NIPPLE(48")	325164600		1
16	LIQUID RECEIVER PIPE ASS'Y	325165100		1
17	LIQUID RECEIVER(48")	325164800		1
18	FILTER DRYER	372002900		1
19	WATER COND OUT PIPE(WATER-1700)	325165200		1
20	WATER COND IN PIPE(WATER-1700)	325165300		1
21	ADJ P-SENSING C-PIPE(WATER-2000)	325165800		1
22	ADJ P-SENSING PIPE(WATER-2000)	325165500		1
23	EVA SENSOR SB(BLACK)	655008200		1
24	EVA SENSOR SB(BLUE)	655008210		1
25	EVA SENSOR SB(YELLOW)	655008220		1
26	SENSOR CLIP	224002400		3
27	FOAM SENSOR INSULATION	306043300		1
28				
29				
30				
31				
32				
33				
34				

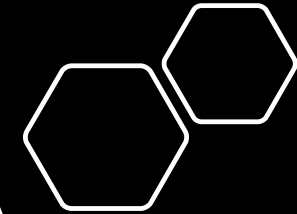

IM-Series  
Part List



# Part List

## IM-2000 Water Cooled

### [ REFRIGERATION PARTS ]

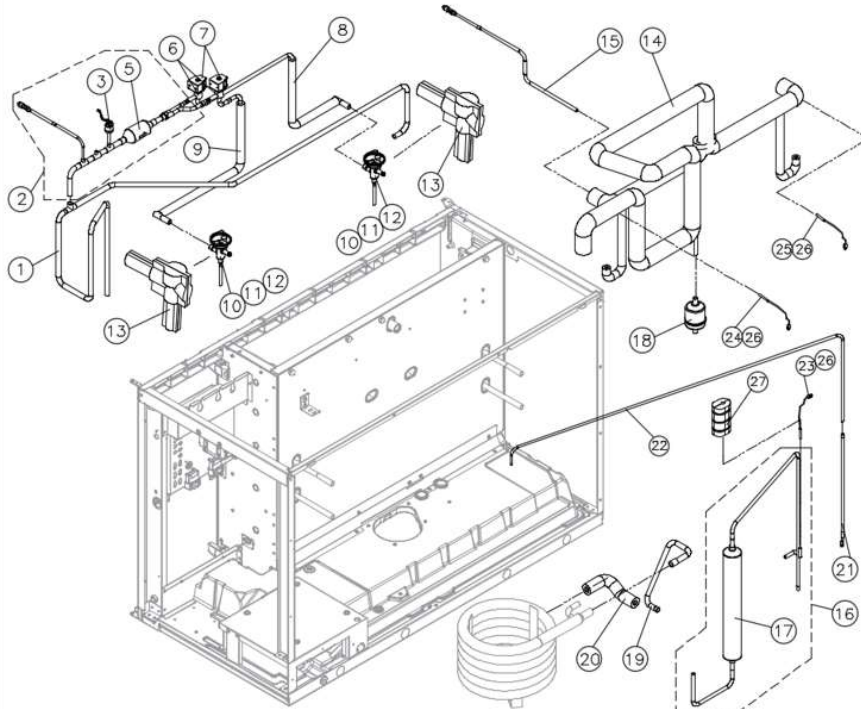

NO	ITEMS	CODE	EXW USD	Q.TY
1	DISCHARGE PIPE ASS'Y(WATER-2000)	433047600		1
2	HOT GAS PIPE ASS'Y(48" WATER)	433047110		1
3	HIGH PRESSURE S/W ASS'Y	429010600		1
4	HIGH PRESSURE S/W ASS'Y(FAN)	429010700		-
5	STRAINER	605002200		1
6	SOLENOID VALVE BODY	340028200		2
7	ASSY SOLENOID VALVE COIL (220V)	429007000		2
8	HOT SOL TO TXV(R) PIPE	325163600		1
9	HOT SOL TO TXV(L) PIPE	325163700		1
10	EXPANSION VALVE-(Inlet Flare TYPE)	340033000		2
11	ORIFICE(#1)	340033100		2
12	EXPANSION IN NUT ASSY	325161300		2
13	FOAM PE (EXPANSION)	306016700		2
14	HEAT EXCHANGE PIPE ASSY(WATER-2000)	433047700		1
15	SUCTION CHARGE NIPPLE(48")	325164600		1
16	LIQUID RECEIVER PIPE ASS'Y	325164200		1
17	LIQUID RECEIVER(48")	325164800		1
18	FILTER DRYER	372002900		1
19	WATER COND OUT(WATER-2000)	325164300		1
20	WATER COND IN(WATER-2000)	325164400		1
21	ADJ P-SENSING C-PIPE(WATER-2000)	325165800		1
22	ADJ P-SENSING PIPE(WATER-2000)	325165500		1
23	EVA SENSOR SB(BLACK)	655008200		1
24	EVA SENSOR SB(BLUE)	655008210		1
25	EVA SENSOR SB(YELLOW)	655008220		1
26	SENSOR CLIP	224002400		3
27	FOAM SENSOR INSULATION	306043300		1
28				
29				
30				
31				
32				
33				
34				

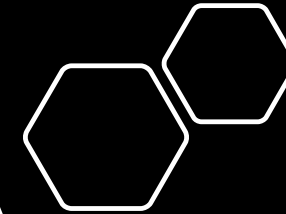

IM-Series  
Part List

# Part List

IM-1700/2000 Water Cooled

[ BASE & FRAME ASSY ]

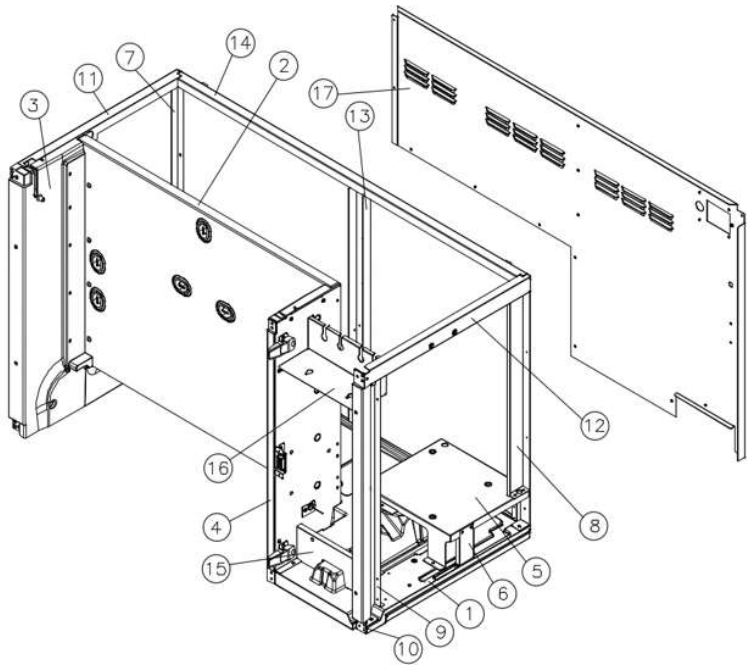

NO	ITEMS	CODE	EXW USD	Q.TY
1	BASE PLATE FOAM ASSY(48")	483032800		1
2	EVA. BACK PANEL ASS'Y(48")	422004000		1
3	EVA S-PANEL ASS'Y(L)	420049700		1
4	EVA S-PANEL ASS'Y(R)	420053000		1
5	SUPPORT COMP(48")	320594200		1
6	SUPPORT COMP. BRACKET	320593800		1
7	SIDE REAR FRAME(L)	348011300		1
8	SIDE REAR FRAME-R(48")	348021700		1
9	FRONT SIDE FRAME-R(48")	348021000		1
10	HINGE BASE BRACKET	301218900		1
11	SIDE TOP FRAME(L)	348010700		1
12	SIDE TOP FRAME-R(48")	348021100		1
13	REAR MIDDLE FRAME(48")	348021800		1
14	REAR TOP FRAME(48")	348021500		1
15	CONTROL BOTTOM-REINFORCE	348021600		1
16	CONTROL TOP-REINFORCE	348021400		1
17	BACK PANEL(48";WATER)	349109300		1
18				
19				
20				
21				
22				
23				
24				
25				
26				
27				
28				
29				
30				
31				
32				
33				
34				
35				

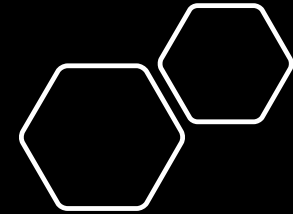

## Reliable Operations & Longevity

- Ice is digested and sanitation and bacteria control must be checked to ensure the machine is safe by keeping it clean.
- 80-85% of machine failures are due to poor install, lack of cleaning, inadequate water treatment, or airborne slime (Bacteria).
- **Citryne by Systems IV** for all machines with pH over 7.0
- Carbon filtration removes chlorine. If there is slime or growth inside of the machine it is from airborne particulate. Carbon removes chlorine.
- Cleaning requires both Ice machine cleaner & sanitizer and should be done under good conditions 1-2 times per year.

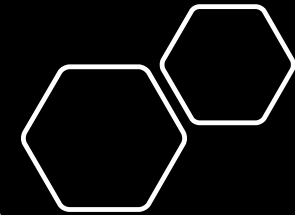

Citryne Water Filtration

## HOW DOES CITRYNE FILTRATION WORK

### Chelation Process

The Systems IV water treatment systems use patent pending technology to soften hard water based on the scientific process of chelation in which the metal ions causing hard water, principally calcium and magnesium, are bound to the chelating agent in our FDA approved, proprietary formulation, which keeps the minerals (calcium and magnesium) soluble and unable to bind to cause hard water problems. The resulting water is soft and healthy for all of your equipment needs.



The ideal pH level of drinking water is between 6 and 8.5. The pH value of water is used to determine whether water is hard or soft. Pure water has a pH of 7, and water lower than 7 pH is considered acidic. Citryne is for all ice makers with water pH above 7. For systems with pH 7 or below use carbon & polyphosphate filters.

Citryne is used to facilitate the chelation process.



CITRYNE™ is a food grade, biodegradable formulation that eliminates scale buildup. With its FDA approved ingredients, CITRYNE™ can be used on equipment without having to stop water flow. The CITRYNE formulation not only removes existing scale buildup, but will eliminate future potential scale buildup.

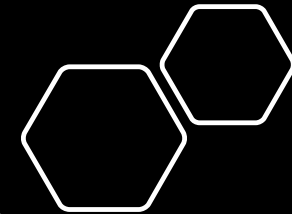

Citryne Water Filtration

**THANK YOU**

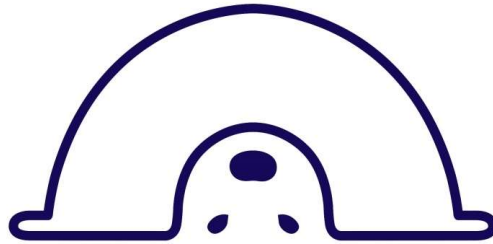

**ICETRO**

**America**