

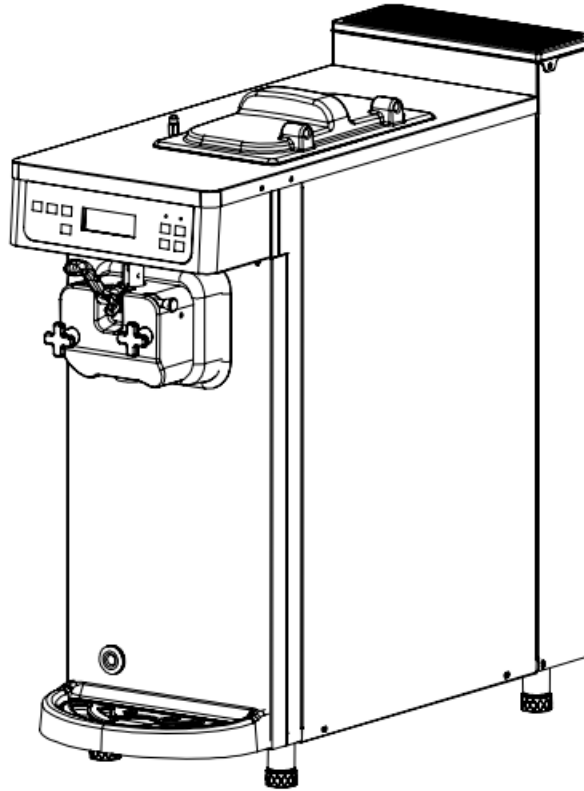

OPERATOR'S MANUAL



ISI-161TI COMPACT SOFT SERVE & FROZEN YOGURT MACHINE

Operating Instructions

ISI-161TI

June 2022
(Updated for North America July 2024)

Complete this page for quick reference when service is required:

Taylor distributor: _____

Address: _____

Phone: _____

Fax: _____

E-mail: _____

Service: _____

Parts: _____

Date of Installation: _____

Information found on the data label:

Model Number: _____

Serial Number: _____

Electrical Specs: Voltage _____ Cycle _____

Phase _____

Maximum Fuse Size: _____ A

Minimum Wire Ampacity: _____ A

Note: Continuing research results in steady improvements; therefore, information in this manual is subject to change without notice.

Note: Only instructions originating from the factory or its authorized translation representative(s) are considered to be the original set of instructions.

© July 2024 ICETRO AMERICA, INC

Any unauthorized reproduction, disclosure, or distribution of copies by any person of any portion of this work may be a violation of Copyright Law of the United States of America and other countries, could result in the awarding of Statutory Damages of up to \$250,000 (17 USC 504) for infringement, and may result in further civil and criminal penalties.

All rights reserved.



Thank you for purchasing an ICETRO soft serve dessert and frozen yogurt freezer. For correct use and maintenance of this machine, please read the manual carefully. If a problem occurs while using the unit, refer to this manual for troubleshooting. This manual contains a product warranty, so keep it for future reference. ICETRO equipment should only be installed by a qualified TAYLOR distributor installation professional.

If parts or accessories not provided by your TAYLOR distributor are utilized on this equipment or are installed by anyone other than a TAYLOR distributor installation professional, it can void the warranty.

The functions and specifications shown in this manual and on the website are subject to change without notice. Please visit our website at <http://www.icetro.com> to obtain the latest specifications.

This soft serve product machine offers the following advantages:

- **Simple installation**
Easy to install thanks to compact design and small footprint.
- **Minimized noise**
With a high efficiency and low noise motor, the cooling system creates minimal noise or vibration.
- **Microprocessor control system**
Use of a state-of-the-art microprocessor control system achieves an optimal cooling system.
- **Ergonomic button premium LCD display panel**
Push button design for easy operation.
- **Taste and Texture Control System** Separate speed controls for producing and dispensing soft serve products.

Table of Contents

Section 1	Safety	1
Section 2	Parts Identification	4
Section 3	Specifications	6
Section 4	User Interface	7
	Check Prior to Use	7
	Button Display Names and Functions	8
	Modes – Detailed Description of Each Mode Function.....	9
	Check the Setting	11
	Check the Record.....	12
	Change the Setting.....	13
Section 5	Operating Procedures	14
	Making Soft Serve	14
	Soft Serve Dispense Speed Control.....	17
	Adjustment Method for Feed Tube... ..	18
	Cleaning Method	19
	Unpacking and Installation	22
	Beater and Beater Cover Assembly Method	24
	How to Upgrade the Program.....	26
	How to download new software to USB memory stick	27
Section 6	Troubleshooting Guide	28
	Cautions for Operation of Mini Soft Serve Machine	28
	Before Requesting Service.....	29
	Replacement Cycle of Consumable Parts.....	30
	Error Codes and Corrective Actions	31

Section 7	Parts List.....	33
	Operator Parts.....	33
	Beater Assembly	34
Section 8	Warranty	35

Caution and warning symbols are intended to alert the user and prevent accidents or danger due to improper use. Please familiarize yourself with these symbols and their meanings accordingly.



If you ignore this symbol and wrongly use the equipment, it may cause fire, serious injury or death.



Ignoring the warning symbol and incorrect use of equipment can result in injury or death.



This means that it can cause injury or property damage when the details are violated.

※ Personal Injury

Minor cuts, burns or electric shocks that do not need hospitalization or long-term hospitalization.

※ Property Loss

Loss or damage caused to buildings and property.

[Each symbol has the following meanings]



This symbol means danger is possible under certain conditions.



This symbol means never to do the described action.



This symbol means not to touch specific parts with bare hands.



This symbol means to unplug the power from the outlet.



Must be grounded.



This symbol means not to disassemble the unit.



This symbol means to be careful because there is a possibility of electric shock.



For relocation of the equipment, call an authorized ICETRO distributor. *Machine may present a tipping hazard unless properly installed. It should be installed in accordance with related regulations such as the road and traffic act, the firefighting act and the food sanitation act.*

※ Call your distributor.



Only authorized ICETRO service personnel should perform installation and repairs on this machine. Incorrect service or repair *may cause fire, electric shock or injury.*

※: If you think the unit needs service, call your distributor or service technician.



Keep the power cable away from heat and heat sources. Excessive heat can *damage the power cord, resulting in fire or electric shock.*



If the power cable needs replacement or repair, contact authorized ICETRO service personnel.



Do not inject flammable material such as benzene, gasoline, paint thinner or LP gas into the machine or store flammable materials near the machine. *Explosion, fire or injury may occur.*



Before cleaning the inside of the unit, unplug from the Ground Fault Circuit Interrupter (GFCI) wearing rubber gloves. *Failure to wear rubber gloves may result in electrical shock or injury.*



Do not disassemble or alter the unit. *Electric shock, fire or injury may occur*



Keep your warning and caution labels clean for easy legibility. *If the user misunderstands the content of such a label, serious accident or injury may occur.*



Do not put anything on the power cable. Make sure that the power cable is not twisted or knotted. *Fire or electric shock may occur.*



Stop using the machine, if you find the power cable or any other cable to be defective. *Fire or electric shock may occur.*



Do not spray or use any flammable products (insecticide, solvents, deodorizers etc) near the machine. *Fire or electric shock may occur.*



Machine operates best at room temperature between 10~30°C (50 – 80 degrees F)



Do not touch the power cable or any electric part with wet hands. *Death or injury may occur.*



Stop operating the unit if you notice any unusual noise, smell or smoke coming from it. *Continued operation under such conditions may result in electric shock or fire.*



When you replenish soft serve product ingredients, do not allow outside moisture to get into any interior electric part. *Defective operation may occur.*



Make sure that no electrical part of this unit has come into contact with water. *If the unit has been immersed in water (for example, due to flooding) call an authorized ICETRO service center for assistance. Fire or electric shock due to electric leakage may occur.*



Do not touch any moving part inside the machine. *Serious injury can occur.*



Do not climb onto the unit or shake or tilt it. *Tipping or damage may occur.*



When you dispose of the unit call your distributor to determine proper disposal method. Follow all local safety and disposal regulations.

※ Call your distributor.



If you sell or relinquish your ICETRO unit, make sure to provide the correct user's manual with it. *Without the manual, an accident may occur because of erroneous handling or operation.*



Do not place any obstacle in front of the air vent. *It may adversely affect unit's performance.*



While operating the unit close the upper cap completely to keep out bugs, dust and foreign materials.



Never operate the discharge lever during sterilization or defrosting. *Hot material can be discharged and it may cause burns.*



Do not install unit on a tilted surface. *Physical injury or equipment damage can occur.*



Do not apply excessive force or impact to the unit. *Damage to the machine can occur.*



Do not use or store any flammable or combustible materials near the unit. *Fire or electrical shocks can occur.*



Do not press "WASH" button when cylinder is empty. Drum bearing can be damaged because there is no lubrication.



To produce safe, consistent soft serve product it is recommended to pasteurize or clean this unit every day according to instructions. *Neglecting the heat treatment or cleaning process will result in product spoilage.*



Do not place containers, utensils, or any other items on top of the unit. *These can fall into the unit, causing electrical shock or equipment damage.*



Do not install machine near dust, moisture, or water. *Electrical shock, fire or other dangerous conditions may result.*



Do not let untrained personnel touch or operate the machine. The machine can be damaged and injury may occur.



If unit will be left unused for an extended period, close the water supply valve and disconnect from power source.



If there is water inside the power supply, turn off power and disconnect unit from GFCI. Unit, power cord and GFCI must be completely dry before returning to use.



Do not change or make modifications to the power cord. *Modifications can cause fire.*



Do not turn the power ON/OFF with the circuit breaker continuously. *It can cause electrical shocks or fire.*



Do not connect too many devices into one electrical outlet. Dedicate one outlet to this machine. *Overloaded circuits cause fire.*



Do not touch the GFCI with wet hands. *It can cause electrical shocks or fire.*

Section 2

Parts Identification

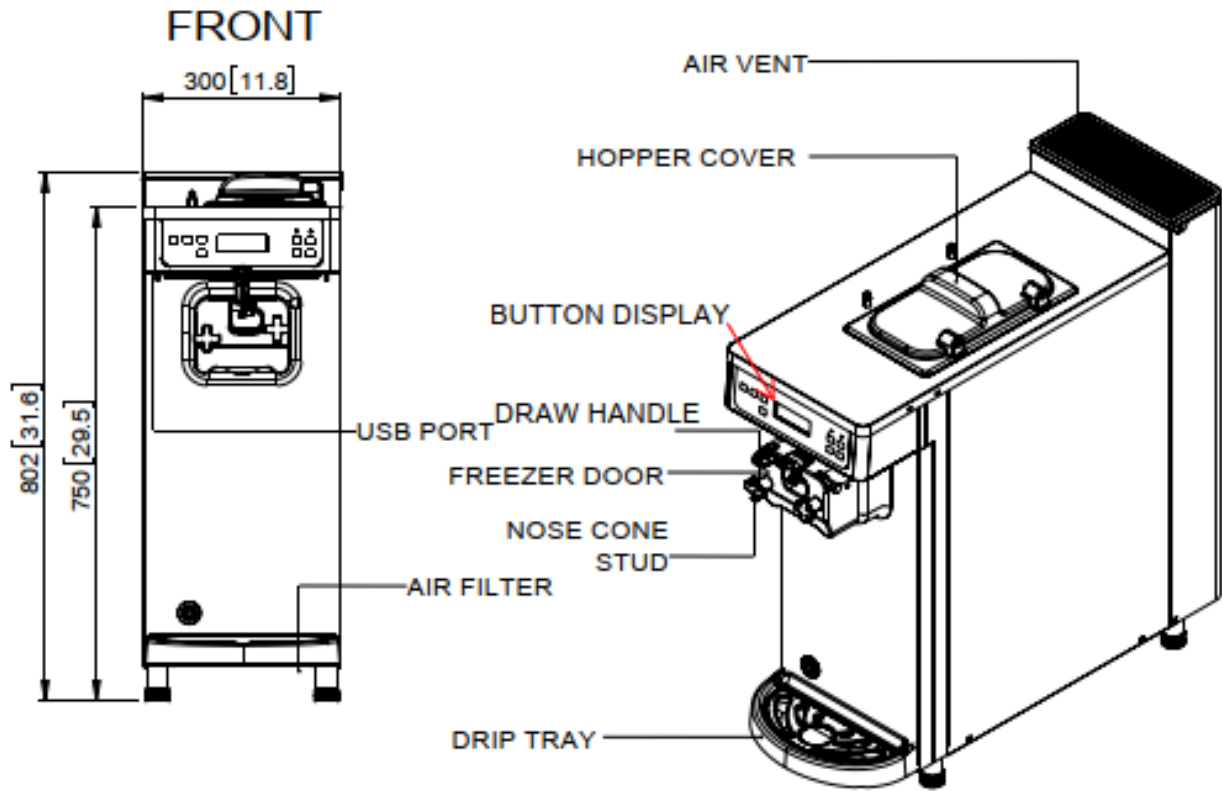

LEFT SIDE

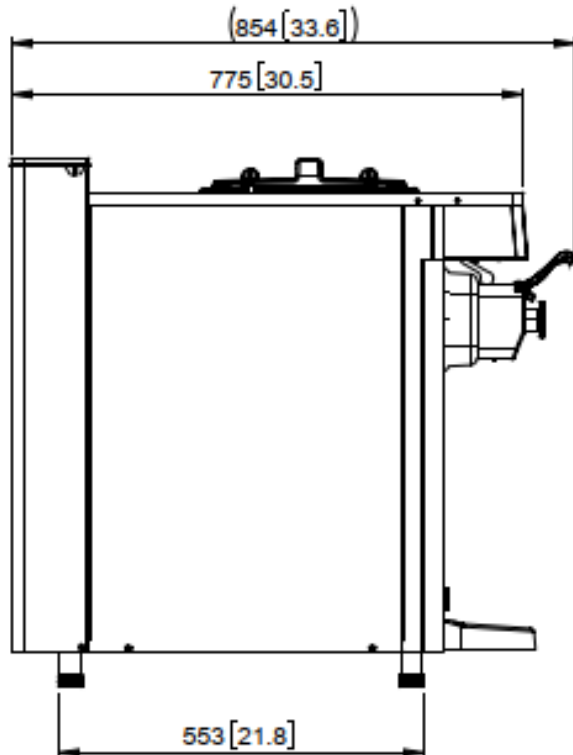

RIGHT SIDE

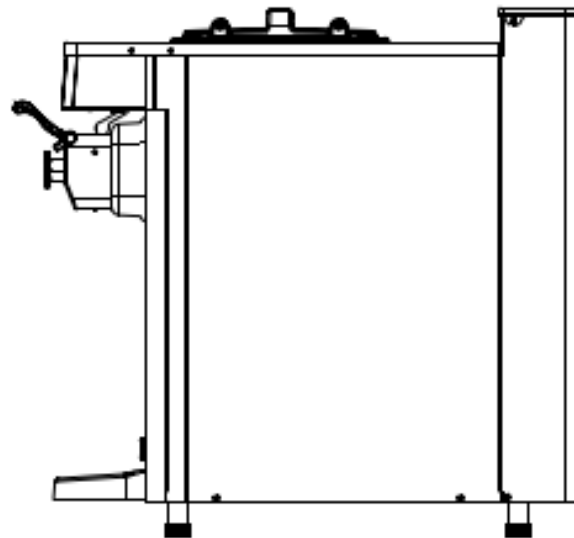
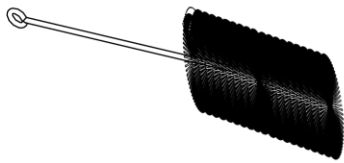
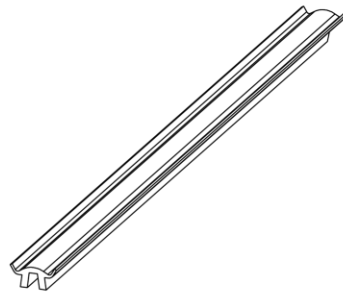

Figure 1

ACCESSORIES & ATTACHMENTS



CYLINDER ("DRUM")
BRUSH
1EA



SCRAPER BLADE
6EA

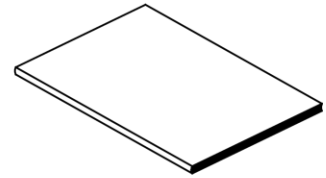

MANUAL
1EA



FREEZER DOOR
BRUSH
1EA



FEED TUBE
1EA

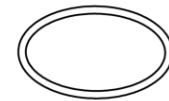

FREEZER DOOR GASKET
1EA



FEED TUBE GASKET
1EA



FEED TUBE BODY
BRUSH
1EA



DRAW VALVE GASKET
2EA

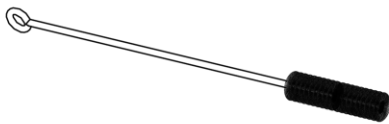

FEED TUBE
BRUSH
1EA

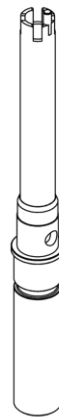

FEED TUBE BODY
1EA



BEATER BLADE BEARING
1EA

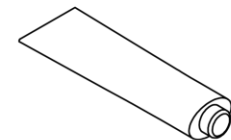

LUBRICANT - FOOD GRADE
1EA

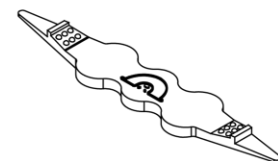

O-RING REMOVAL TOOL
1EA

Figure 2

Section 3

Specifications

CLASSIFICATION		SPECIFICATION
Product name		Soft Serve Machine
Model name		ISI-161TI
Voltage Rating		1 PH, 115V, 60Hz
Power consumption		1.32 KW
Amps		13 A
Dimensions including lever and feet	WIDTH(W)	300 mm (12")
	DEPTH(D)	775 mm (31")
	HEIGHT(H)	750 mm (30")
Cylinder capacity		1.4 L (1.5 qt)
Hopper capacity		3 L (3.2 qt)
Consecutive selling (30 second interval)		3 Cups (15 Cups)
Initial sales hours		8 minutes once operator hits "AUTO"
Hopper and Standby temperature		Maintain under 5° C (41° F)
Compressor		Hermetic
Air filter for condenser		Located at bottom
Refrigerant amount		500 g (17.64 oz.)
Refrigerant Material		R-404A
Display system		LCD screen
Net weight (before crating)		93 kg (205 lbs)
Gross weight (Shipping)		98 kg (216 lbs)



Install machine in a dedicated outlet equipped with a GFCI (Ground Fault Circuit Interrupter) with more than 15 amps

The power cable must be connected before the unit can be operated normally



For your information

If you intend to leave machine unused for an extended period, wash and sanitize it and turn off the water supply valve.

Check Prior to Use

- **Do not obstruct air intake and discharge**
Air suction and discharge must be kept clear for optimum cooling performance.
- **Recommended Daily Cleaning**
It is recommended that the barrel, the hopper, agitation impeller, beater, feed tube, draw spout and the draw valves are cleaned every day.
- **Weekly Air Filter Cleaning**
For better machine performance, clean air filter weekly.
- **Clean the condenser once a month.**
Clean the condenser at least once a month. More frequent cleaning is recommended.

Button Display Names and Functions

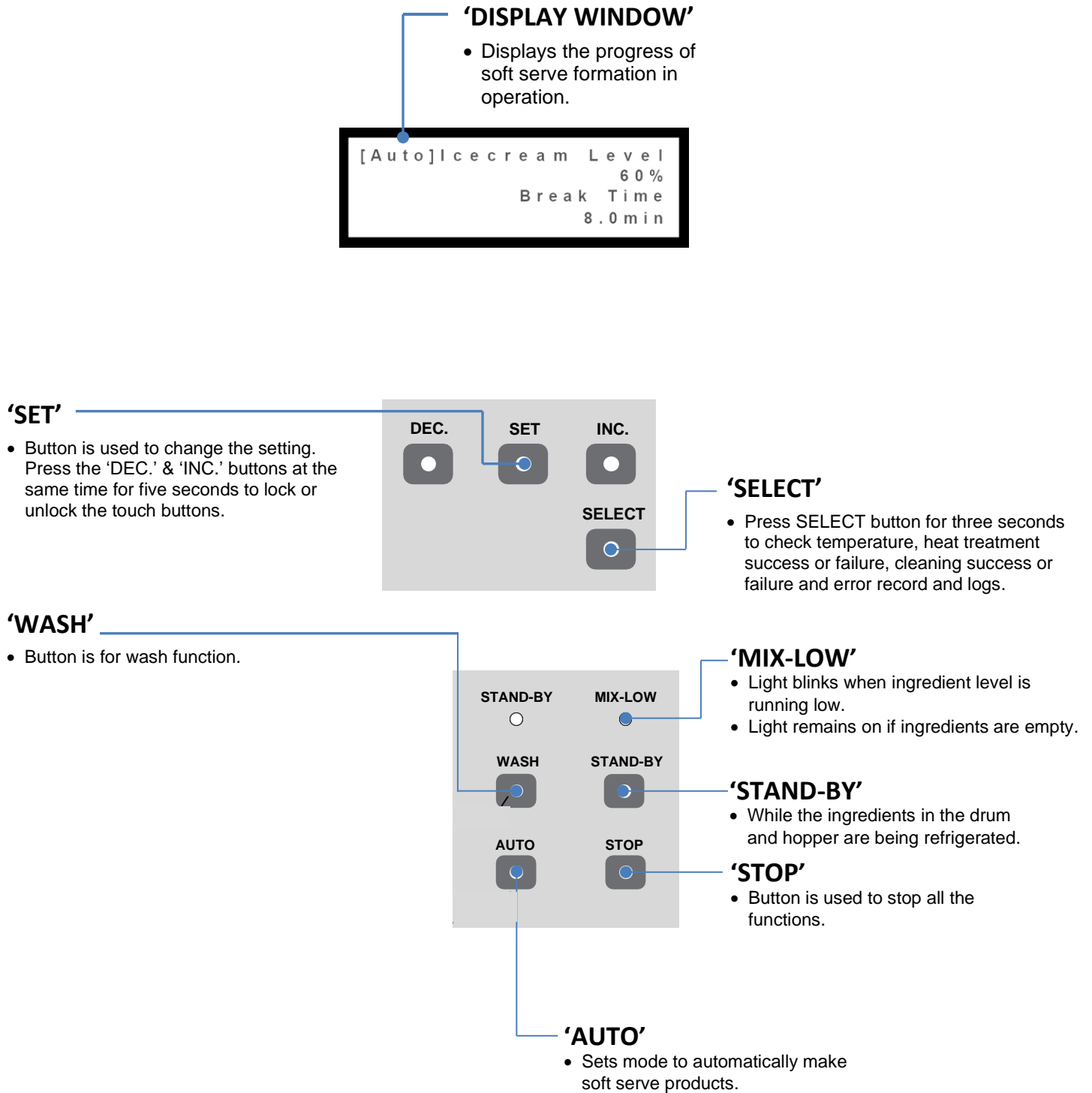

Figure 3

'AUTO' Mode' Making soft serve product

Pour the raw mix or ingredients into the hopper and press the 'AUTO' button. The following status display will be shown.



Figure 4

Current level of soft serve product is indicated.

To check 'AUTO' Mode level set up

Press the 'SELECT' button to display the level setting (Current, Set-up, No-load) of product.

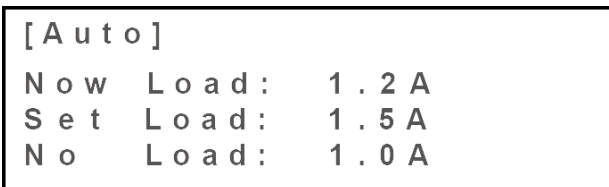

Figure 5

To change product level setting, press the 'SET' button for three seconds.

(For further details, see 'Adjusting Setting Value' section.)

To check condition of ingredients

To confirm the condition of the ingredients in the hopper, press 'SET' button.

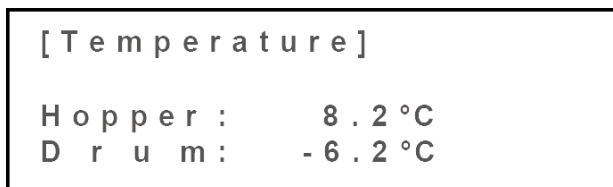

Figure 6

Information including the temperature of the hopper and cylinder can be obtained. To change the temperature, press the 'SET' button for three seconds. *(For further details, see 'Adjusting Setting Value' section.)*

AUTO Mode continued...

When soft serve product has been produced, the compressor will be shut down for a while, and the status will be displayed.

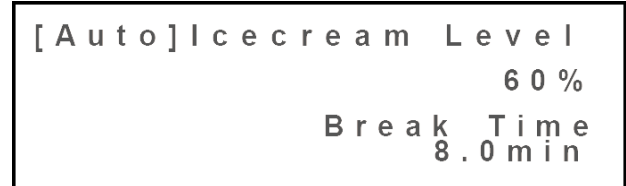

Figure 7

TIME: The time remaining until compressor restarts will be displayed in minutes (min). If the ambient temperature is high, the compressor may start up sooner than the indicated time.

PRODUCT LEVEL: Soft serve product level in the unit is indicated. Starting at 100%, the value will decrease as time passes, faster if the ambient temperature is higher.



For your information



The soft serve product level default is set by the manufacturer. The types of ingredients and amount of wear to the scraper blades will impact correct settings. These should be adjusted accordingly by the installation technician.

When changing the ingredients, consult with a TAYLOR distributor installation professional to adjust the settings.

'WASH' Mode

WASH Mode is used to operate the hopper agitator and the cylinder beater motor. WASH Mode is primarily used to remove water and liquid raw material.

```
[ W a s h i n g ]
N o w       :   0 . 5 A
H o p p e r :   8 . 0 ° C
D r u m     :  - 5 . 0 ° C
```

Figure 7

Window displays the present current value of the beater motor.

 **For your information**

 While the 'PASTEURIZE' function is operating, do not touch beater cover or hopper cover because they are hot. Do not disassemble or modify. The hot ingredients can cause burn injuries.

 If the 'PASTEURIZE' function has not been done, remove any ingredients or product in the hopper and perform cleaning.

Check the setting

Press the 'SET' button lightly to enter the mode where set-up value can be confirmed.

In the confirmation mode, Press the 'SET' button to see the setting values in the following order.

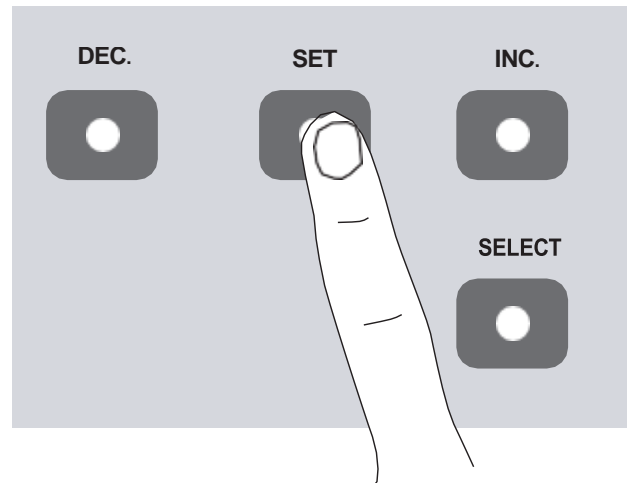

Figure 8

The temperature setting in the hopper and the cylinder is displayed.

```
[ T e m p e r a t u r e ]
H o p p e r :       8 . 2 ° C
D r u m   :       - 6 . 2 ° C
```

Figure 9

The rated voltage, frequency and current of the freezer are displayed.

```

[ Power ]
Voltage   :           2 2 0 V
Frequency :           6 0 H z
Current   :           1 . 2 A

```

Figure 10

The version No. of the software operating the Main PCB, Vend PCB, Control PCB, and Door PCB are displayed.

```

[ Version ]
Main:     1 . 0
Control:  1 . 0
voice:    0 . 1

```

Figure 11

The time and date set up in the freezer are displayed.

```

[ Current time ]

2 0 1 2 . 1 2 . 0 3
1 7 : 0 1 : 0 2

```

Figure 12

No-load current of the beater motor is displayed.
 First: No-load current when controlling soft serve product first Run: No-load current when controlling product during operation

```

[ No load Current 1 ]
First   :   3 . 0 A
Run     :   3 . 0 A
Draw    :   2 . 1 A

```

Figure 13

Draw: No-load current when discharging After Draw: No-load current after draw

```

[ No load Current 2 ]
After Draw :   3 . 0 A

```

Figure 14

Check the record

Press the 'SELECT' button for three seconds to check the records in the order of Sterilization, Washing, and Error.

Display items can be changed with the 'DEC.', 'INC.' buttons.

To check the date, there has to be at least one record. Press the 'SELECT' button shortly to see the year, month and date. Multiple records can be viewed using the 'DEC.' and 'INC.' buttons.

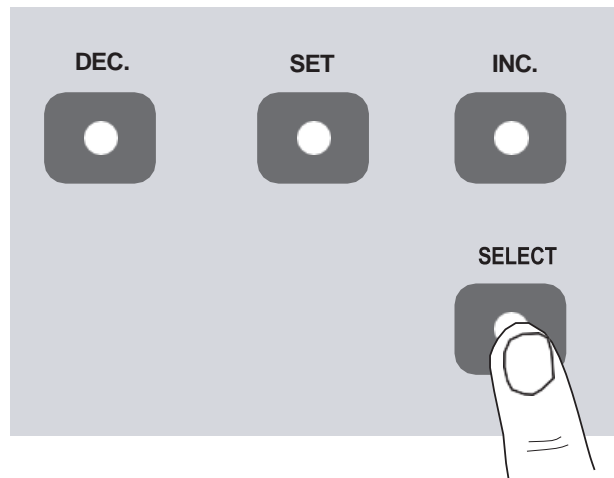

Figure 15

```

[ Wash Succ ]
Total:      0

```

Figure 16

```

[ Wash Fail ]
Total:      0

```

Figure 17

```

[ Error ]
Total:     0

```

Figure 18

Change the setting

Press the 'SET' button for three seconds to enter the setting change mode as follows.

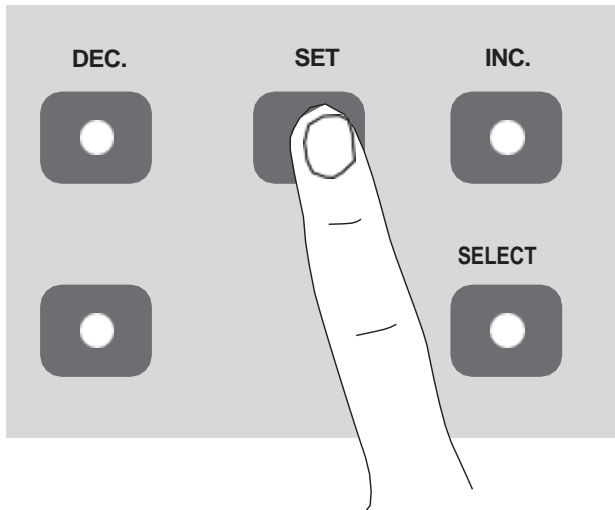

Figure 19

Move to other items using the 'DEC.' and 'INC.' buttons. Press the 'SET' button. While the setting value is flashing, change the value using the 'DEC.' and 'INC.' buttons.

Press the 'SET' button again to go to another item. To change several values in an item, move to another value using the 'SET' button.

When the last value is changed, the first screen of the item appears. If you press the 'SET' button again for three seconds, then you can exit the setting change mode.

3-1 : Adjust viscosity set point.

This item is used to adjust the viscosity set point by amperage draw (current draw) in product formation stages such as first, Run, Draw and After draw. The larger the number is, the harder the soft serve level is. The smaller, the softer it is. If viscosity set points are too high, then the number of soft serve cups sold can be decreased.

```
[ 3 - 1 ] S e t t i n g   C u r r e n t  
F i r s t   :   1 . 0 A  
R u n     :   1 . 2 A  
D r a w   :   1 . 8 A
```

Figure 20

The level of soft serve at the start of production. After 100%, production will be done at the level as shown at 'Run'. 'Draw' is applied when discharging product.

```
[ 3 - 1 ] S e t t i n g   C u r r e n t  
A f t e r  
D r a w   :   1 . 0 A
```

Figure 21

3-4: Adjust the hopper cooling temperature.

This item is used to adjust the cooling temperature of the ingredients in the hopper. The larger the number is, the higher the storage temperature is. The smaller the number is, the lower the storage temperature is.

If you keep the storage temperature too low, then it can form ice in the ingredients in the hopper. If you set it too high, it can cause decay of the ingredient in the hopper.

```
[ 3 - 4 ] C o n t r o l   T e m p .  
H o p p e r ( A U T O + S T A N D B Y )  
4 . 0 C
```

Figure 22

3-5: Voice guidance and volume level can be selected.

Voice guidance time can be set up.

```
[ 3 - 5 ] V o i c e   S e r v i c e
1 . S e r v i c e   :           O n
2 . V o l u m e   :           4
```

Figure 23

3-6: The time and date of the internal clock can be set up.

```
[ 3 - 6 ] T i m e   S e t t i n g
E x t e r n a l   c l o c k :   O n
      2 0 1 2 . 0 6 . 2 6
      1 9 : 3 2 : 0 0
```

Figure 24



Important

The soft serve level is configured to the default factory setting and shall be adjusted depending on the raw materials. Adjust the settings upon consulting with the installation engineer when changing the soft serve level.

Section 5

Operating Procedures

Making soft serve

1. Open hopper cover and put in the correct amount of ingredients.

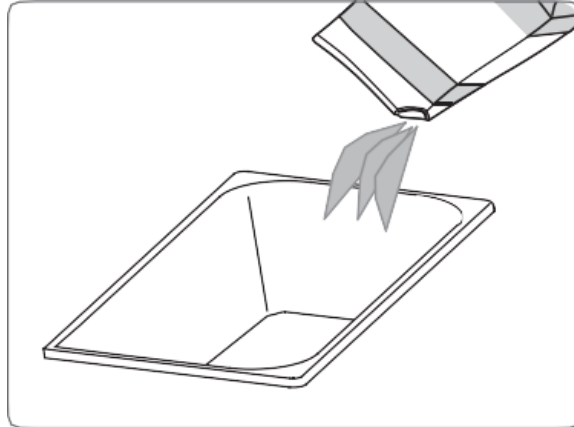

Figure 25

2. Insert the feed tube body and feed tube into the hopper.

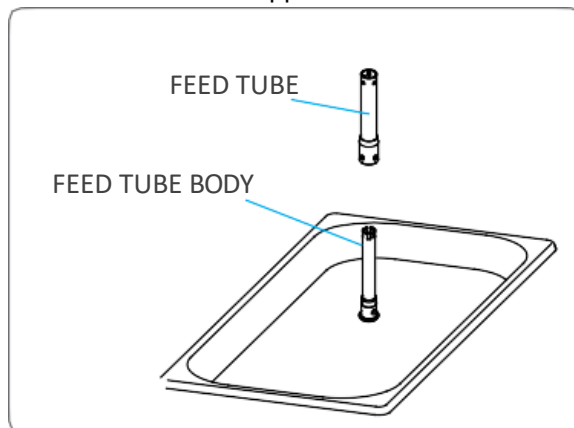

Figure 26

3. Close the feed tube hole and insert the agitator paddle. Discharge 300g and pour it back into the hopper with the ingredients.

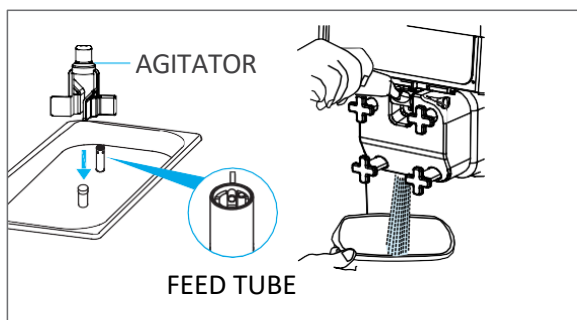

Figure 27

4. Operate the machine by pressing the AUTO button.

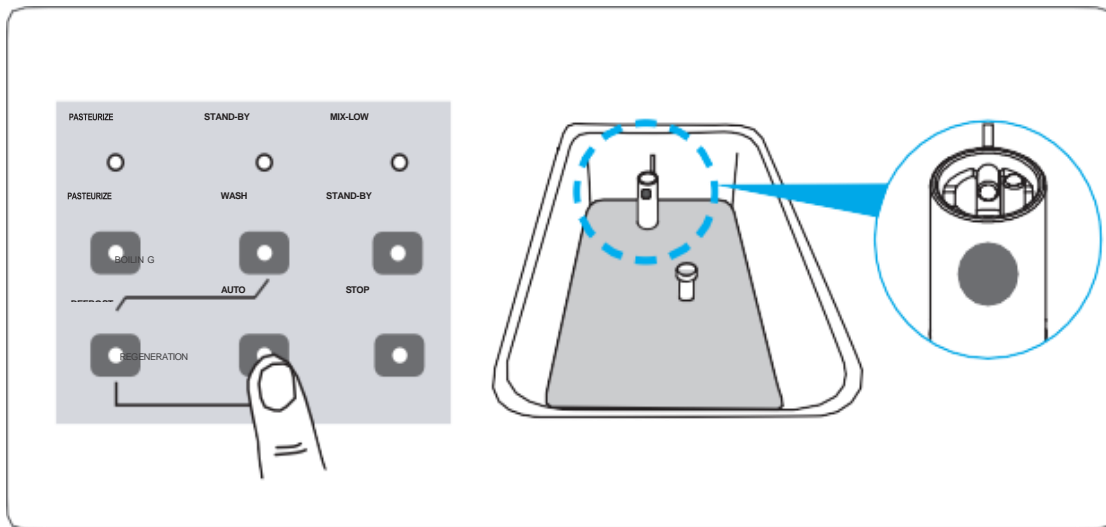

Figure 28

5. Open the feed tube hole after ice cream is fully formed.



For your information



The smaller the feed tube hole is, the higher the overrun (air content) will be.

- In case of continuous sales, the ingredient supply gets lower and the soft serve is let out slowly.
- The feed tube hole can get clogged, so check it and wash it periodically during use.
- The manufacturer will not be liable for any problems (e.g., spoilage of materials, overcooling, non-production of soft serve) caused by using materials in non-frozen state 10°C (50°F).
- Using very thick ingredients such as acai berry, please remove feed tube and its body. Using feed tube with these types of ingredients may starve the cylinder.

LEFT BLANK ON PURPOSE

Soft serve dispense speed control

1. By adjusting 'Screw Adjust' at the bottom of the lever (out lever), you can adjust the discharging speed of the soft serve.

As shown in the figure below, release the 'Screw Adjust' to increase the discharging speed of the soft serve.

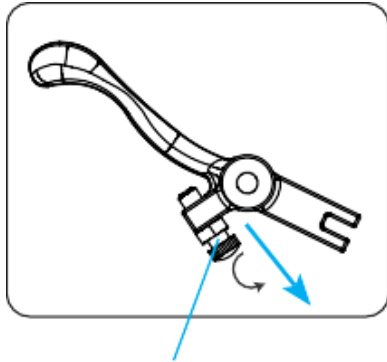

Screw Adjust

Figure 29

1. As shown in the figure below, fasten the 'Screw Adjust' to decrease the discharging speed of the soft serve.

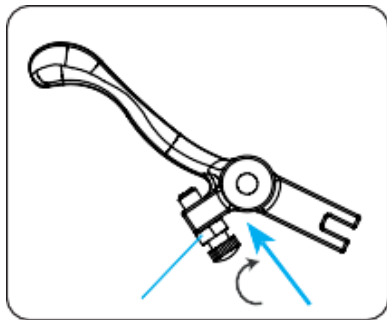

Figure 30

※ After setting up the adjustment bolt position, tighten the set nut 'a' to fix the 'Screw Adjust' position and maintain constant dispensing volume.

<Maximum open> - Soft serve dispensing speed is maximized. Please avoid loosening the bolt more than shown in the right picture. Otherwise, dispensing can be interrupted for the Screw Adjust may touch the beater cover.

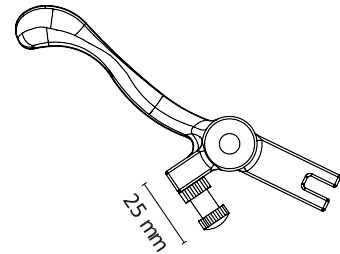

Figure 31

<Minimum open> - Soft serve dispensing speed is minimized when the Screw Adjust is tighten as shown in the right picture.

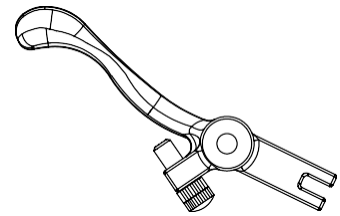

Figure 32



For your information

- If you loosen the Screw Adjust it increases flow rate of product. It will quickly starve the cylinder so that it becomes unable to dispense. Therefore, it is recommended to adjust the dispensing speed (flow rate) to one cup every 6 to 8 seconds.

Adjustment method for Feed Tube

The feed tube is made up of two parts.

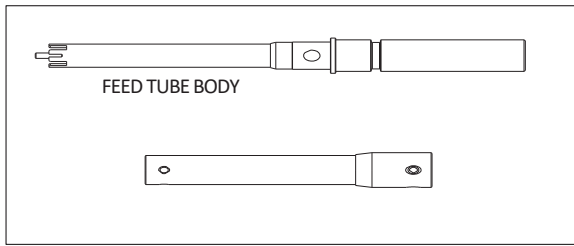

Figure 33

The part that is inserted into the hole of the hopper is called the body and a tube is inserted into this. The tube has a hole at the top and at the bottom. It can't be inserted in the reverse direction.



Figure 34

Figure 55 shows the feed tube with a blocked hole.

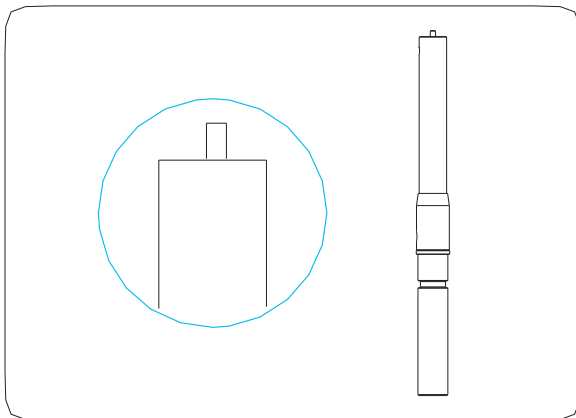

Figure 35

If you align the protrusion of the upper area of the feed tube body with the area having no hole in the upper area of the tube, then the hole in the lower area of the feed tube body will be blocked.

Condition of use:

1. Initial soft serve making
2. "Heating" mode executed
3. "Regeneration" mode executed

Figure 56 shows the feed tube aligned with a large hole.

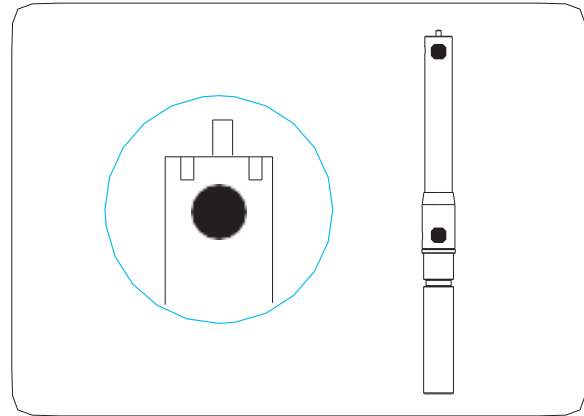

Figure 36

Align the protrusion of the upper area of the feed tube body with the large hole in the upper area of the tube. Decrease the overrun and increase the amount of ingredients injection in this way when you need continuous vending of the product.

Condition of use:

1. When the "Auto" mode is executed

Figure 57 shows the feed tube aligned with a small hole.

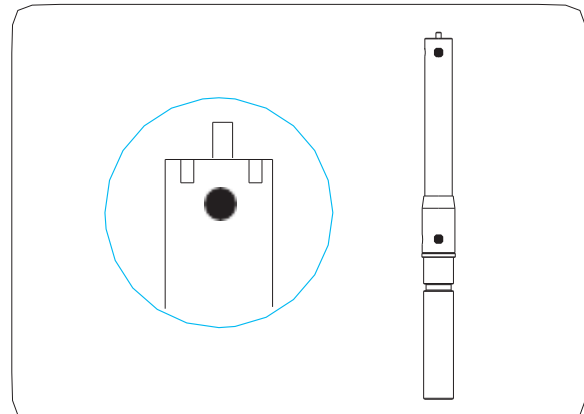

Figure 37

Align the protrusion of the upper area of the feed tube body with the small hole in the upper area of the tube. Then it will be aligned with the small hole in the lower area of the feed tube body. Increase the overrun and decrease the amount of ingredients in this way when you expect a small amount of sales.

Condition of use:

1. When the "Auto" mode is executed



For your information

A small hole can improve the overrun, but it may depend on the amount of soft serve mix (ingredient) in the freezing cylinder. The lower the amount of mix in the freezing cylinder, the higher the overrun. The higher the amount of mix (ingredient), the lower the overrun.

Figure 58 shows the feed tube aligned with a medium hole.

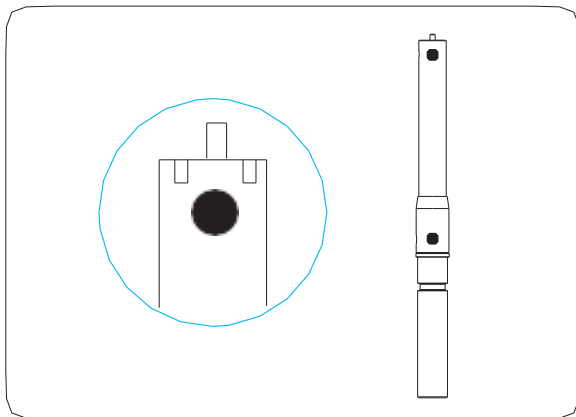

Figure 38

Align the protrusion of the upper area of the feed tube body with the medium hole in the upper area of the tube. Then, it will be aligned with the medium hole in the lower area of the feed tube body. It will make the overrun and the amount of ingredients injection adequate for sales.

Condition of use:

1. When the "Auto" mode is executed

Cleaning method

1. Press 'STOP' button, and then 'WASH' on the operation panel.

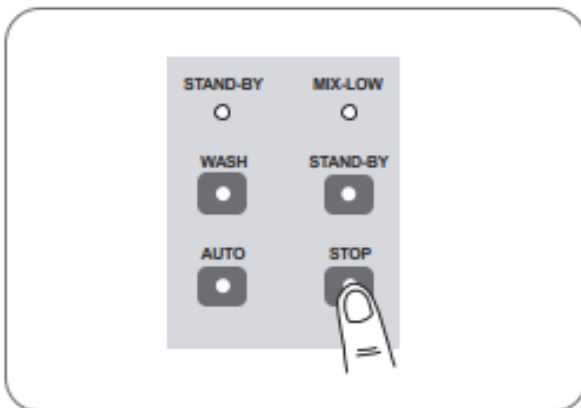

Figure 39

2. Open the cover of the hopper, then remove and clean the feed tube (the body), and agitator paddle.

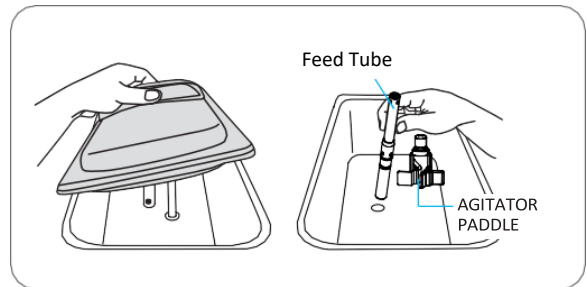

Figure 40

3. Remove the drip tray and place drain bin under the opening.

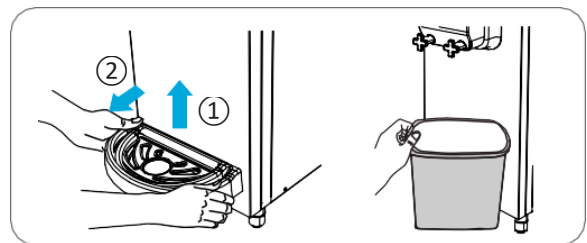

Figure 41

4. Remove the soft serve liquid in the hopper and pour faucet water into it. Repeat it two or three times until you get clean water from it.

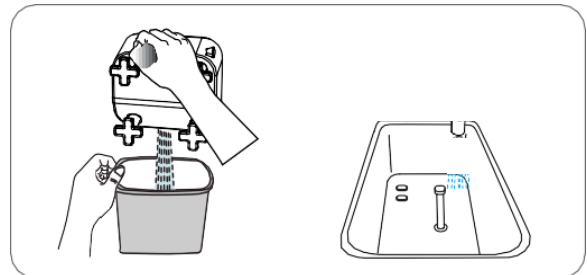

Figure 42

5. In order to remove product residue from the baffle, freezing cylinder, hopper cover, drain hole and water level sensor, use neutral detergent in the clean water with brush.

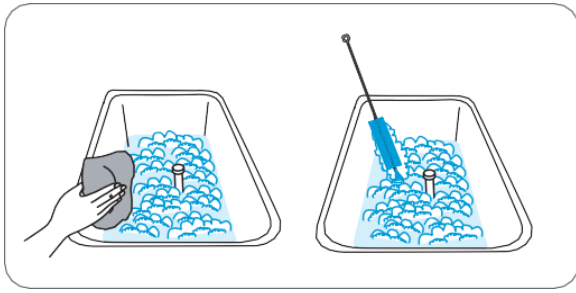

Figure 43

6. After process, press the WASH button to release the water and rinse the machine with clean water.
7. Stop the wash by pressing stop button (do not turn off the power switch) and loosen the freezer door bolts diagonally by the order shown in the picture and separate the freezer door from the soft serve freezer.

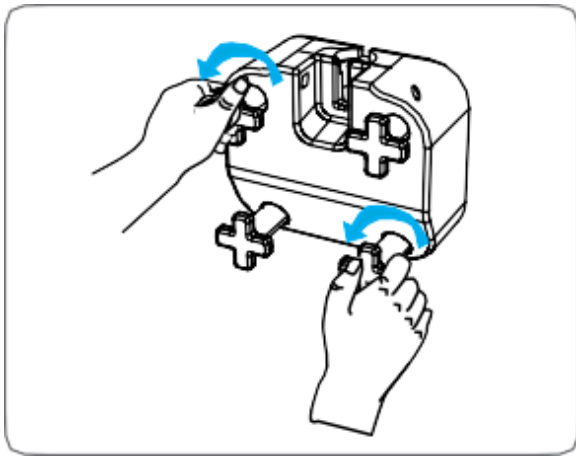

Figure 44

Remove the beater and separate it from the freezing cylinder. Clean the inside of the cylinder with a brush and wipe with a soft cloth.

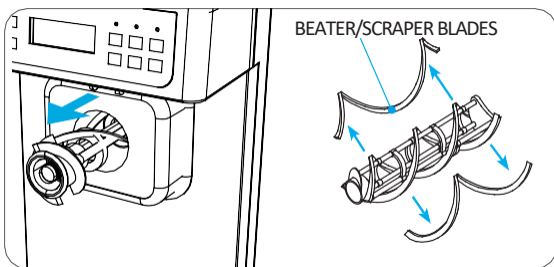

Figure 45

8. Remove the beater blade and clean the blade hole with a brush. Wipe out moisture with a soft cloth.
9. Draw valve handle and pivot pin should be taken out of freezing cylinder door to clean as shown in Figure 66.

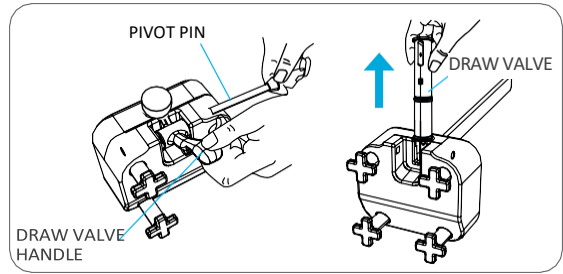

Figure 46

10. Using a brush, clean the inside of the draw valve hole on the freezing cylinder door and remove any remaining moisture with a soft towel.

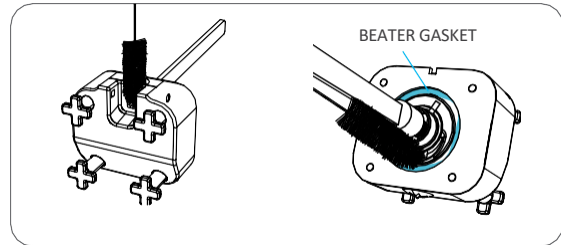

Figure 47

Please use the "O-ring Removal Tool" when removing O-rings from the draw valve to avoid damaging them. Wash the O-rings and draw valve parts thoroughly. Clean the agitator using brushes included with this unit.

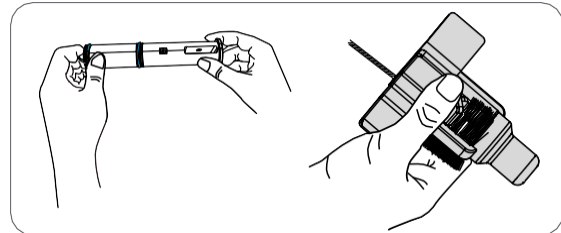

Figure 48

11. Clean feed tube body and tube with brush.

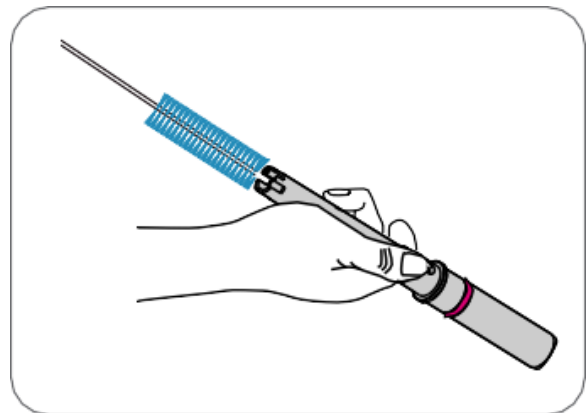

Figure 49

12. After cleaning, dry and reassemble the parts in reverse order.



Caution

- Wear rubber gloves when cleaning the inside of the system. Otherwise, electric shock or injury may be caused.

Condenser and filter cleaning method

1. Filter Cleaning method

The filter is located at the bottom front of the unit, below the drip tray. (See item 3 in Figure 70) Lift and remove the drip tray and splash guard, then gently pull out the filter.

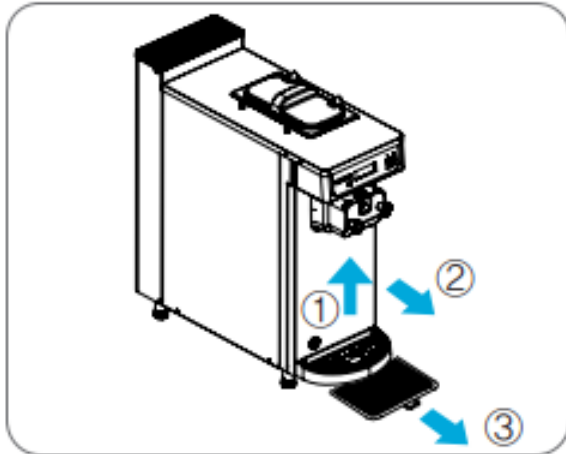

Figure 50

2. Shake off filter dust. Using a brush, wash it thoroughly with water. Figure 71 (After washing dry the filter)

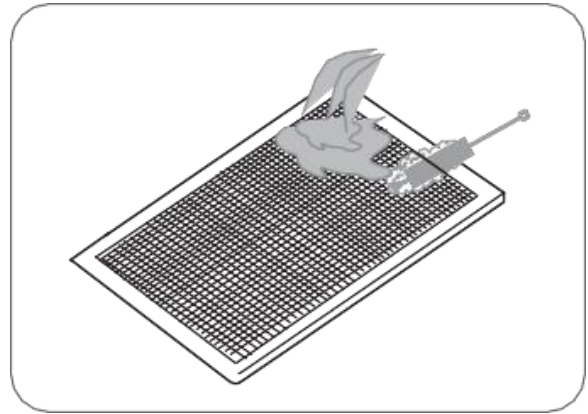

Figure 51

3. When filter is dry replace it back into the machine. Do not run unit without the filter.

The Cleaning cycle:

- Filter: Once a week
- ✘ The dust collection on filter will vary depending on the installed location.
- Condenser: Once a month
- ✘ Call your distributor to clean it.

Unpacking

This soft serve freezer has been fully inspected and tested at the factory prior to shipping. If you detect damage to the wooden package or apparent distortion of the shape of the system after unpacking the unit, immediately inform your distributor or manufacturer.

Find the serial number marked on the packing and the machine before starting installation. Inform us of the serial number if you have any inquiry. Request the dealer or service provider for assistance when the machine is to be moved.

1. Remove the wooden packing, taking care not to damage the exterior of the soft serve freezer.
2. Remove the wooden packaging and the protective tapes and make sure that all parts of the system are complete.

※ When tilting or moving the machine, take care not to overturn the machine.

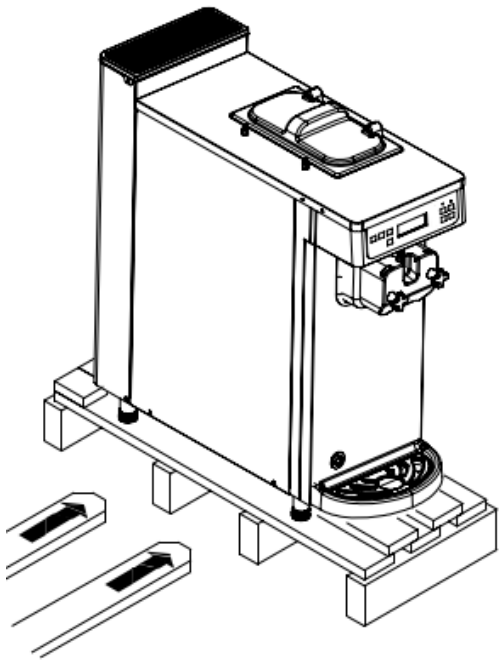

Figure 52

Location and Precautions for Installation

1. Avoid sloping or irregular surface.
Installation on a sloping or irregular surface may result in machine overturning, malfunction, or failure.
2. Avoid direct sunlight, rain, snow, and wind.
Fire or electric shock may occur due to wet or dirty conditions.
3. Avoid the direct exposure to sea wind and hazardous gases. These conditions can impact the taste and quality of the soft serve product.



For your information

- Consult with your nearest TAYLOR distributor to arrange installation of the unit and to ensure optimal performance.
- Change of installation site also requires consultation with nearest TAYLOR distributor.
- Do not install the unit in a place with adverse conditions such as uneven floor, exposure to direct sunlight, dirt, dust or wood shavings, or splashing water.
- Reset the current time and clean the unit when restarting it after a period of non-operation.

Electrical connection

1. Connect the main power for single-phase power distribution box.
2. Install GFCI (with capacity of 15A or higher) in the distribution box.
3. Grounding must be provided for the safe operation of the system.
4. Maintain space of 20"(50cm) or more from the top of unit for ventilation. No space is required for each side and rear side.
5. Precisely seat the rubber feet at the bottom to prevent slipping.

※ Make sure that the air vent is never blocked. Make sure that the air inlet (A) and top exhaust (B) are never blocked.

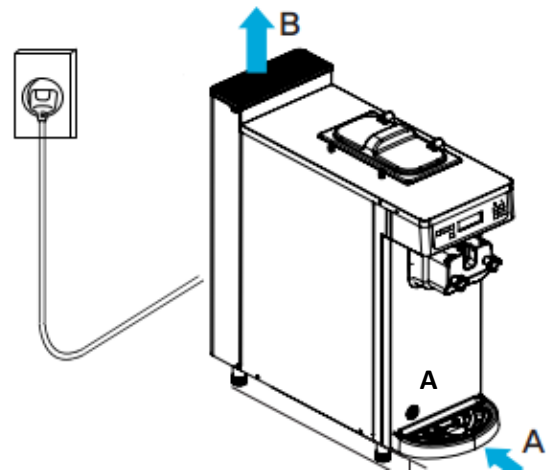

Figure 53 Secure about 50mm space at the bottom.

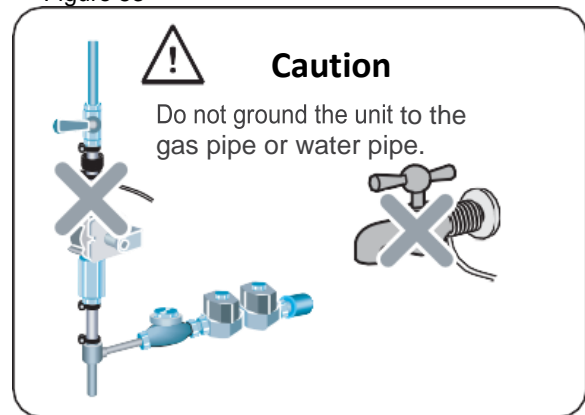

Figure 54



Warning

- Before installing the unit, be sure to earth for a place with no power supply for earth connection.
- Bury the copper plate or ground rod at a depth of 30 cm or more underground.
- Failure to perform groundwork may cause electric shock caused by leakage.

Beater and beater cover assembly method

Beater assembly:

1. Assemble the beater blades by rotating on the beater wing.

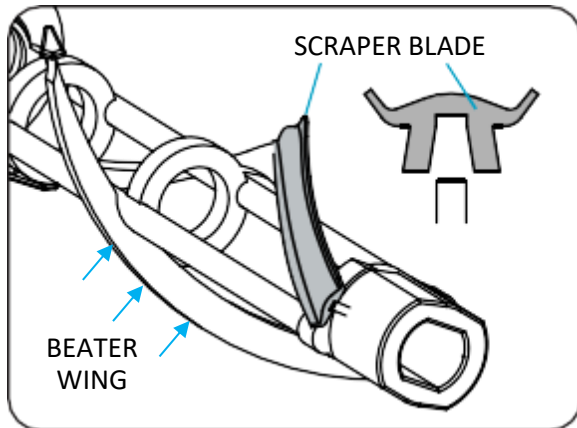

Figure 55

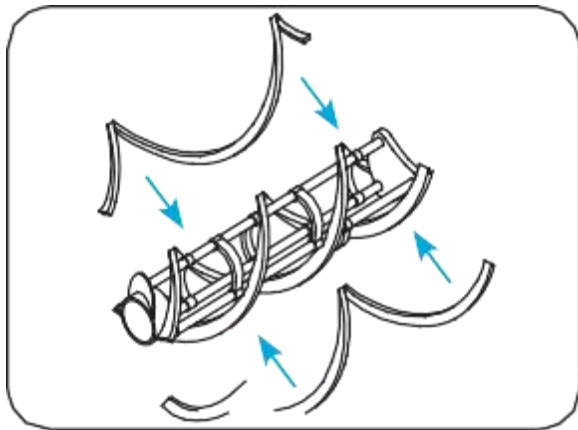

Figure 56

2. Insert the assembled beater assembly into the cylinder.

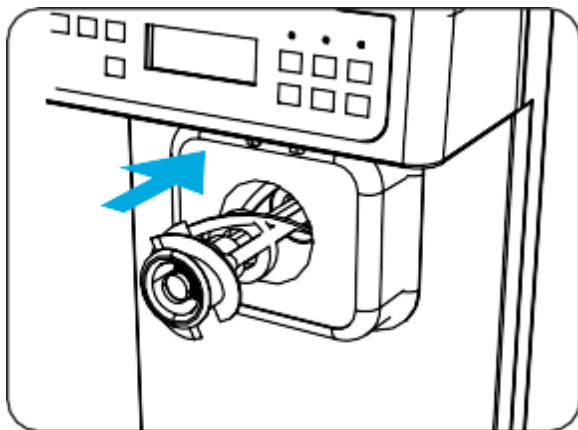

Figure 57

Beater cover assembly:

1. Apply some food grade lubricant on the O-rings of the piston (draw valve) and slowly insert the piston into the piston hole making sure its head is horizontal to the beater cover (freezer cylinder door).

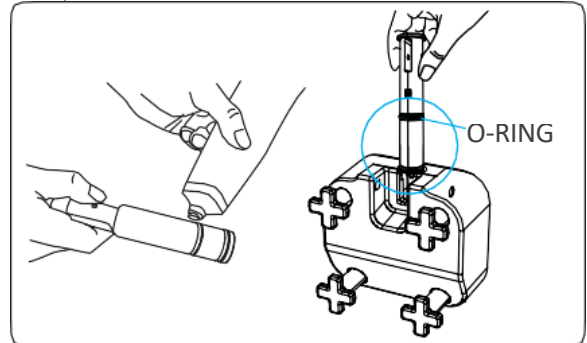

Figure 58

2. Insert the O-ring for the beater cover (freezer cylinder door) along to groove on inner side of the beater cover (freezer cylinder door)

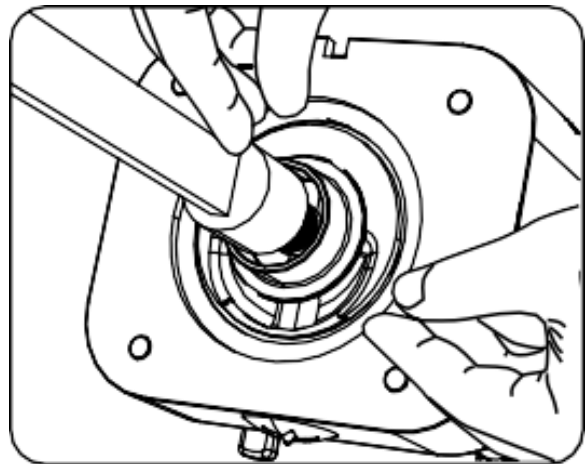

Figure 59

3. Insert the draw handle into the piston hole (draw valve hole) in upper part of draw valve and the pivot lever into the beater cover and the lever hole.

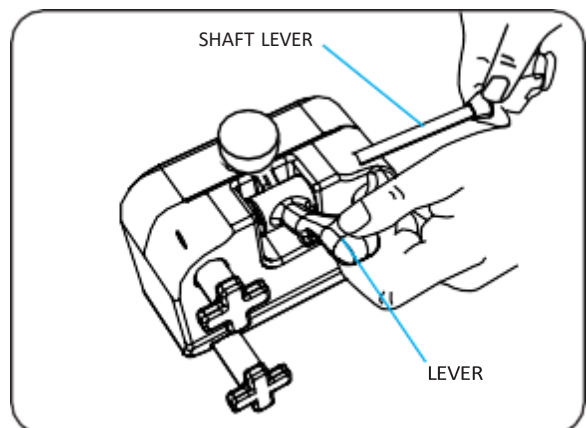

Figure 60

4. Assemble the mixing shaft and the beater bearing.
5. Fully tighten the 4 beater cover nut studs. Soft serve product may leak if they are not fully tightened.

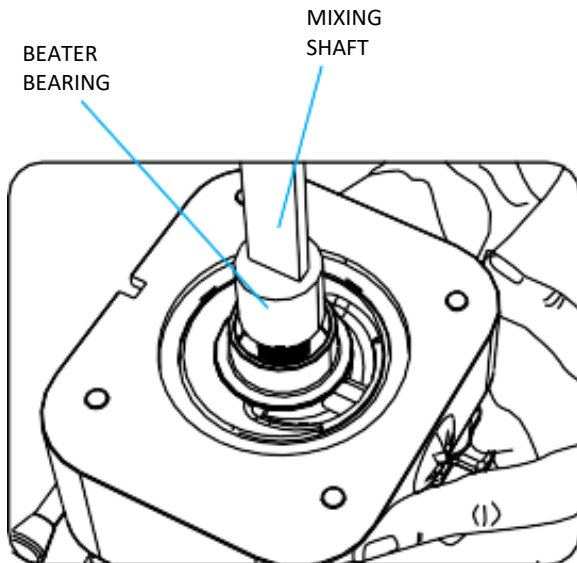
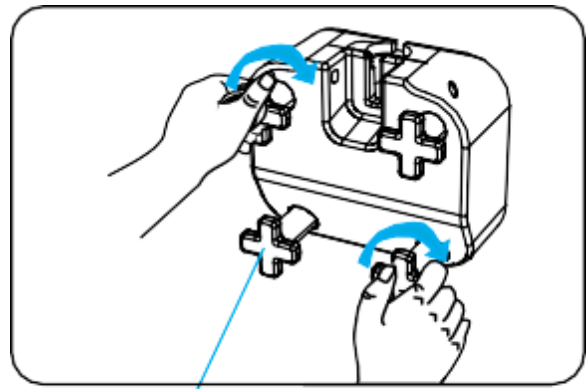

Figure 61



FREEZER DOOR STUD NUT

Figure 62

How to upgrade the program

1. Download the program from our website or the customer service center of the company to a USB driver.
2. Insert the USB memory stick into the USB port on the front of the product.
3. Turn off the power switch on the front side of the unit, and then turn it on.
4. Wait for approximately 5~10 minutes until the front LCD screen lights up.
5. To initialize the unit after software update: Select any other model on menu 4-0, save it and exit. Then return to menu 4-0 and select original model. Save and exit. (For example: ISI-161TH USA to ISI-161TH Korea for reset and come back to ISI-161TH USA.)
6. Power off the product and restart it.
7. Pour soft serve ingredients and use the product as per the instructions herein.

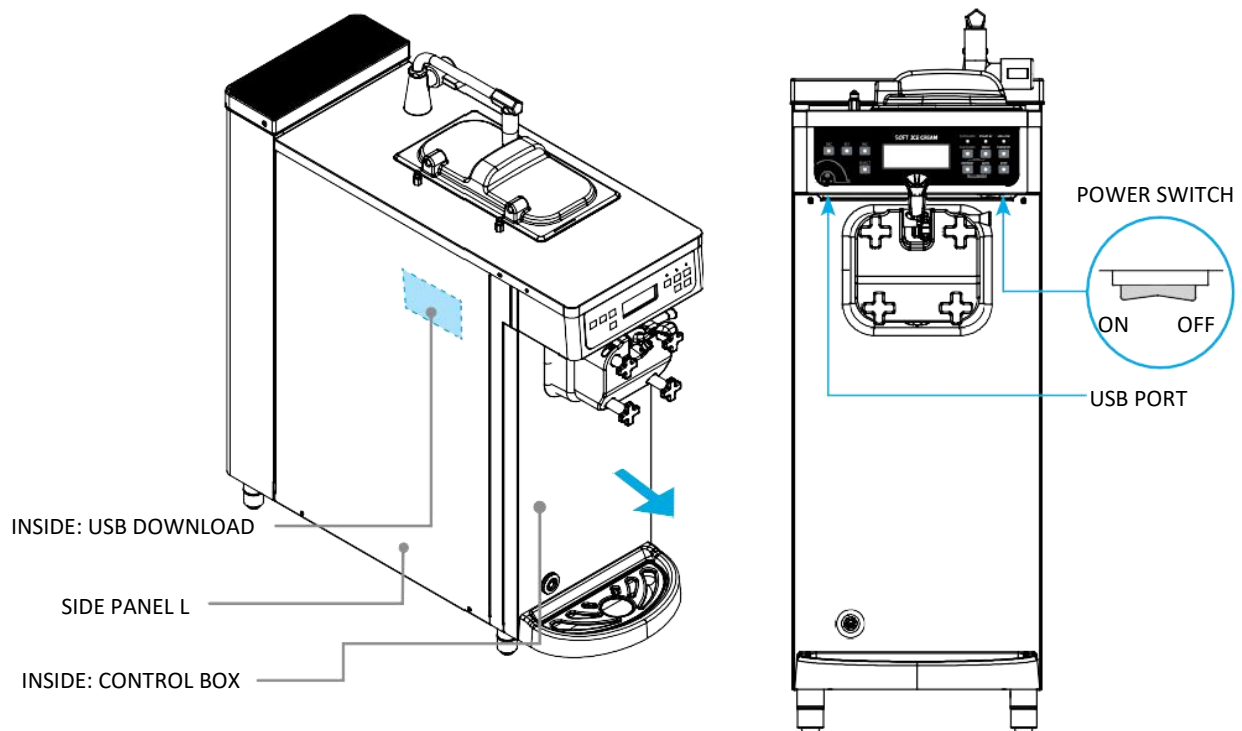

USB DOWNLOAD PCB

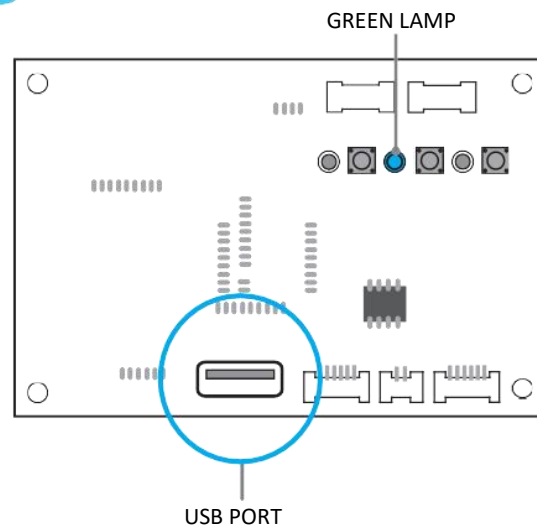

Figure 63

How to download new software to USB memory stick

How to write a new software on USB memory stick.

1. Copy new software on the USB memory stick to folders named "MINI_Main.hex" and "Voice".

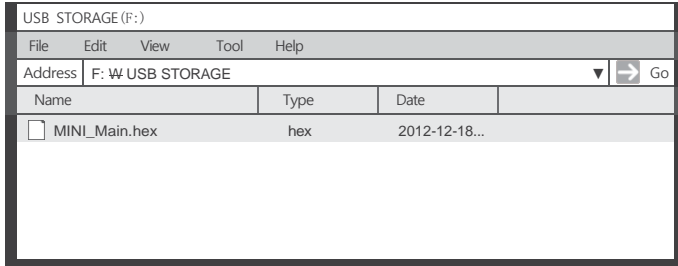

Figure 64

2. Insert the USB memory stick in the USB downloader.
3. Turn on the power.
4. The front LCD will light up when the software is fully downloaded.
5. Reset the product as per the instructions on page 27 after removing the USB memory stick.



For your information

- If upgrade is not complete within 30 minutes, turn off the power, insert the USB memory again, and turn it on again. If the problem persists, please contact your nearest Taylor distributor.
- Delete the date and version from the name of the original file "MINI_Main_2017.02.03.hex" and copy the file as follows: "MINI_Main.hex"

Cautions for operation of soft serve machine

1. We highly recommend using the proper liquid ingredients. If you intend to use powder ingredients by mixing it with water or milk, be sure to follow the mixture ratio suggested by its manufacturer.

(This machine should use properly mixed ingredients in order to produce good-quality soft serve. Please use additional caution if you intend to use powder-type ingredients. They tend to get lumpy or separate over time from the water or milk, which results in over-freezing, poor product quality and issues with machine operation.)

2. Even if you use the proper liquid ingredients, adding an additive to it or arbitrarily adjusting the dilution ratio may result in poor quality of the soft serve or over freezing.

We do not provide warranty or assume responsibility for issues related to the ingredients. Be sure to check and follow the dilution ratio.

3. Powdered ingredients must be mixed manually and slowly.

If the powdered ingredients are mixed fast using mechanical means, too much oxygen will be mixed into the final product, which causes oxidization and coagulation over time.

In this case, the ingredients will become lumpy like pieces of tofu, causing trouble with the supply of the ingredients and over-freezing.

4. Over-freezing may also occur when there is not enough ingredient supplied to the freezing cylinder. Be sure to check the volume of ingredients, so the unit is always operated with a sufficient amount. Due to the nature and viscosity of soft-serve ingredients and “mix” it can get lumpy and block the feed tube (mixing valve) hole through which the ingredients are supplied to the freezing cylinder (drum). Be sure to remove and wash feed tube frequently.
5. If the unit is not used for an extended period of time, ice crystal formation may occur in the freezing cylinder. In this case, the product will become too thin, or over freezing will occur. Be sure to operate the unit on a regular basis even when there is no demand, in order to minimize wait time and to ensure quality of product.
6. Re-use of ingredients will result in poor quality soft serve product and over freezing. When making a fresh batch of product, refill unit with new ingredients and re-start.

Before requesting service

The product freezer can operate abnormally because you are not familiar with the method for use or due to another insignificant reason. It does not necessarily mean a malfunction. In this case, check the following items to resolve a simple problem on your own without the help from your distributor. If you still can't resolve it after checking the following items, please contact your nearest Taylor distributor.

State	Please check
The machine does not work!	<ol style="list-style-type: none"> 1. Contact an electrician or your distributor in case a power supply error occurred. 2. Check whether the circuit breaker and switch are turned off. 3. In case the display (front display) is off, turn the ELB (breaker) and switch on.
The machine works but does not make ice cream!	<ol style="list-style-type: none"> 1. Check whether dust is stacked in the ventilation hole. Take out the filter and remove the dust. 2. If the machine is close to the bottom and has no ventilation, it can occur. Please, secure it at least 50mm from the bottom. 3. Check whether the feed tube hole is blocked and if so clean out the hole. 4. Check whether the temperature in the ventilation hole (inhalation hole) is high. Make the inhalation temperature of the condenser lower than 38°C.
Soft serve texture is thin!	<ol style="list-style-type: none"> 1. Check whether the feed tube is inserted. 2. In case there are no sales for more than 3 hours, please melt the soft serve and remake product by using the "regeneration" function (cover the feed tube hole during regeneration). 3. Check whether a sweet content of an ingredient has changed from what was used before and adjust the setting value (When the raw material is different from the one used during the initial installation, adjust the level value of the product or contact your distributor).
Unit makes too much noise!	<ol style="list-style-type: none"> 1. This product is a commercial machine and has some operation noise when compared to household appliances. This product is designed to generate noise that is less than 70dB. Contact your distributor in case abnormal noise is generated during machine operation.
Unit does not discharge sufficient serving size	<ol style="list-style-type: none"> 1. The operator can adjust the amount of soft serve product dispensed. The factory default amount is set but may require change depending on the condition of the ingredient or overrun. Be sure to refer to the user manual to adjust the amount appropriately. 2. 'MIX LOW' lamp is blinking. In the case of MIX LOW, the amount of product dispensed can become small. Replenish the ingredients. 3. The amount of product discharged can change by changing the size of the feed tube hole. 4. Was the level of viscosity set too high? If the level is too high, machine may fail to discharge product. However, if the level is low, too much product may be dispensed.
Too much product is discharged!	<ol style="list-style-type: none"> 1. The operator can adjust the amount of product being discharged. The mini soft serve machine is set up with factory default settings. These can be changed depending on the condition of the ingredients or overrun. Be sure to refer to the user manual to adjust the settings and amount appropriately. 2. The soft serve product will get thinner over time, causing the unit to discharge product too quickly. If the product gets too thin, use the regeneration function to restore the quality. 3. Discharge amount can be adjusted by changing the size of the feed tube hole. Amount can be large when a large hole is used. The amount will decrease if the hole is smaller. 4. Was the product level set too low? If the level is too low, too much product may be dispensed. But if the level is too high, machine may fail to discharge product.
Overrun seems to be poor (Soft serve product seems to lose air)	<ol style="list-style-type: none"> 1. Please familiarize yourself with the instructions on how to make soft serve product included in this user manual. 2. Overrun will be improved with a smaller feed tube hole. 3. Overrun may deteriorate after serving product for an extended period of time. If this appears to be the case, cover the feed tube hole in the tank to defrost the ingredients fully and check the amount in the hopper. Overrun will be improved by discharging 300g of ingredient from the cylinder and producing product again. Discharging too much ingredient (more than 1/3 of the volume in the cylinder) will cause over-freezing and poor production of soft serve.

State	Please check
There are lumps of milk fat in the product.	<ol style="list-style-type: none"> If the ingredient has too much milk fat, lumps may formed. The feed tube hole needs to be smaller if you serve fewer cups of soft serve per unit hour. Try defrosting and resuming soft serve production if soft serve appears to be too thin. (This will not be the case if a sufficient number of cups of soft serve are served.)
The amount of soft serve produced in a session does not seem to be consistent!	<ol style="list-style-type: none"> Please check if the level of soft serve is set too high. The deviation of amount of produced soft serve will get bigger if the level of soft serve is set too high. Please understand that precise control of the amount is extremely difficult since the machine controls the amount of production based on the time of operation, making it sensitive to the quality and conditions of ingredient, amount of ingredient in the hopper, the quality after producing soft serve, and changes in quality after no production for an extended period. Please familiarize yourself with this user manual to ensure consistency of operation.
The soft serve has gone bad!	<ol style="list-style-type: none"> This product requires cleaning on a daily basis, Any ingredient left in the unit after a day's service must be discarded before starting production the next day. Start each day with a fresh batch of mix or ingredient. This product requires at least "Pasteurization" if cleaning is not possible. We do not assume responsibility for spoilage or poor product quality if these requirements are not followed.

Replacement cycle of consumable parts

PART NAME	Replacement cycle	Quantity
DOOR GASKET	3 months	1EA
DRAW VALVE O-RING	3 months	2EA
FEED TUBE O-RING	3 months	1EA

Error codes and corrective actions

The soft serve freezer may malfunction due to incorrect operation procedure or a trivial cause other than machine defect or failure. If the following corrective actions fail to correct the problem, or the error code is not presented below, or the same error persists, contact the nearest Taylor distributor.

※ Before contacting the Taylor distributor, turn power off, wait for five minutes, then turn power on and start the machine again.

Error code	Possible Cause	Corrective Action	Release	Action
Er00	Mix Out	Low quantity of ingredients	Refill raw material in the hopper	Auto release Stop
Er01	Hop. Sensor Op.	Cooler sensor OPEN	Sensor failure (contact A/S Center)	Auto release Stop
Er02	Hop. Sensor St.	Cooler sensor SHORT	Sensor failure (contact A/S Center)	Auto release Stop
Er03	Cyl. Sensor Op.	Cooler sensor OPEN	Sensor failure (contact A/S Center)	Auto release Stop
Er04	Cyl. Sensor St.	Cooler sensor SHORT	Sensor failure (contact A/S Center)	Auto release Stop
Er07	EOCR	Motor over current detected	Melt the soft serve and restart the machine	Reset Reset operation
Er08	High Pressure	Over voltage detected	Clean the filter unit, check exhaust air line	Auto release Stop
Er09	noLA	Product immature yet	Refrigerant problem (contact A/S Center)	Auto release operation
Er12	Draw Switch Er.	Discharge lever ERROR	Lift the discharge lever	Auto release operation
Er13	Condenser OH	Abnormal temperature of condenser	Check the vent for clogging.	Auto release operation
Er14	Motor Belt Er.	Defective drive shaft	Melt the soft serve (Regeneration) and restart the machine	Reset Reset operation
Er15	EEPROM Error	EEPROM fault	PCB fault (contact A/S Center)	Reset operation
Er17	Heating Error	Defective sterilization function	Replace the soft serve raw material and clean the machine	Other operation operation
Er18	Cover Error	Defective Freezing Cylinder Door	Mount the Freezing Cylinder Door in correct position	Auto release Stop
Er19	Eva. Sensor Op.	Eva. Sensor OPEN	Sensor failure (contact A/S Center)	Auto release operation
Er20	Eva. Sensor St.	Eva. Sensor SHORT	Sensor failure (contact A/S Center)	Auto release operation
Er21	Motor Power Er.	Failed to detect electric motor current	Machine failure (contact A/S Center)	After reset release Reset operation
Er50	Power IC Er.	Power IC ERROR	Sensor failure (contact A/S Center)	Auto release Stop
Er51	Feed tube Er.	Feed tube sensor error	Sensor failure (contact A/S Center)	Auto release Stop
Er52	Inverter Comm.	Inverter communication error	Sensor failure (contact A/S Center)	Auto release Stop
Er53	Inverter OC	Inverter over current	Sensor failure (contact A/S Center)	Auto release Stop
Er54	Inverter OE	Inverter over voltage	Sensor failure (contact A/S Center)	Auto release Stop
Er55	Inverter OE	Inverter overheat	Sensor failure (contact A/S Center)	Auto release Stop
Er56	Inverter LU	Inverter under voltage	Sensor failure (contact A/S Center)	Auto release Stop
Er57	Inverter TH	Erroneous detection of temperature sensor	Sensor failure (contact A/S Center)	Auto release Stop
Er58	Inverter COM	Communication failure detected	Sensor failure (contact A/S Center)	Auto release Stop
Er59	Inverter OL	Mean overvoltage detected	Sensor failure (contact A/S Center)	Auto release Stop
Er60	Inverter OT	Max. output protection	Sensor failure (contact A/S Center)	Auto release Stop
Er61	Control Comm.	Control pcb communication error	PCB fault (contact A/S Center)	Auto release Stop

Section 7

Parts List

Operator Parts

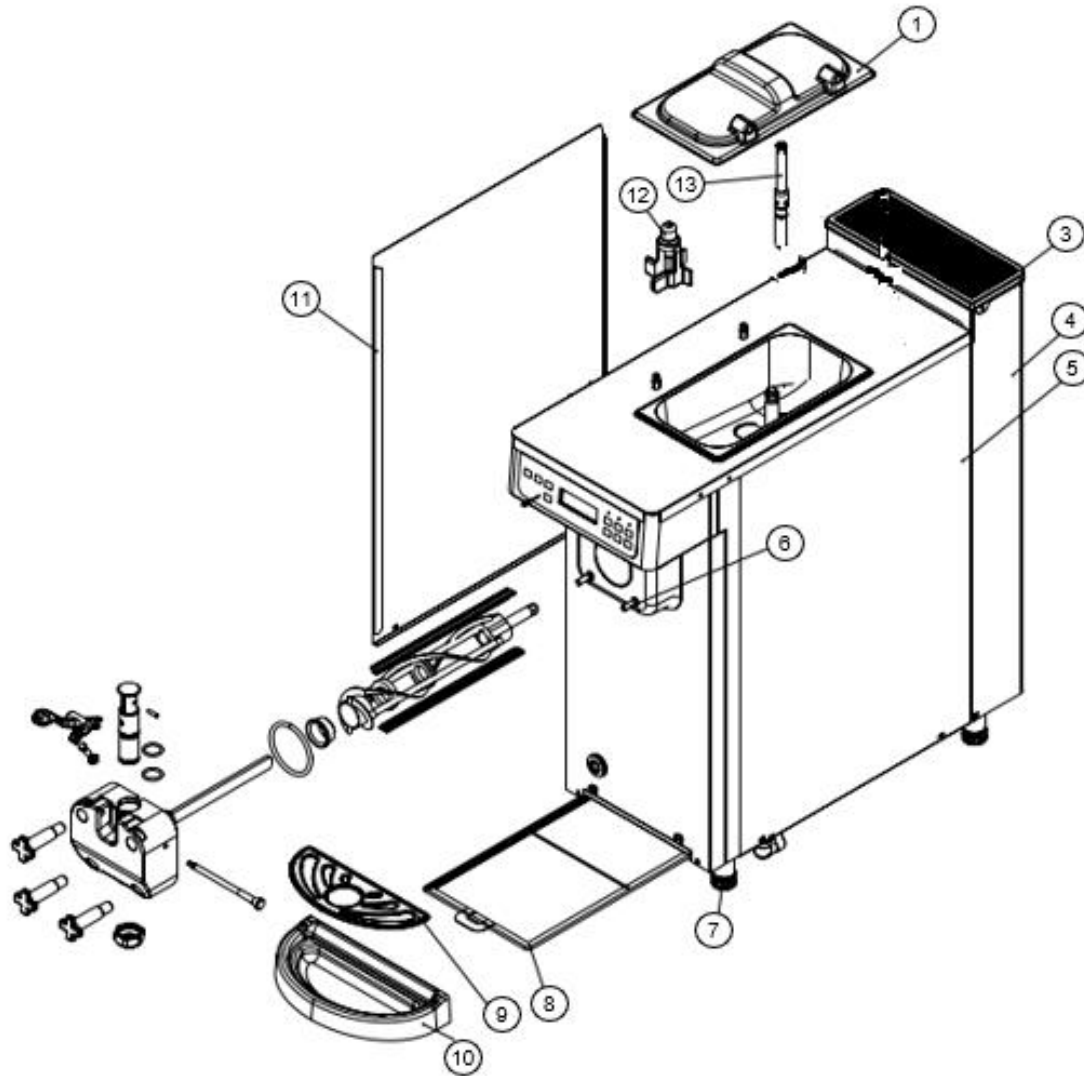

Figure 65

ITEM	DESCRIPTION	Part No.
1	Hopper Cover	317140700
3	Air Vent	317185800
4	Back Panel	317180700
5	Side Panel - Right	317180600
6	Nose Cone Stud	317072600
7	Foot - Rubber	302006600

ITEM	DESCRIPTION	Part No.
8	Air Filter	640007800
9	Shield - Splash	336027900
10	Tray - Drip	336027800
11	Side Panel - Left	317180500
12	Agitator	390001400
13	Feed Tube	729008400

Beater Assembly

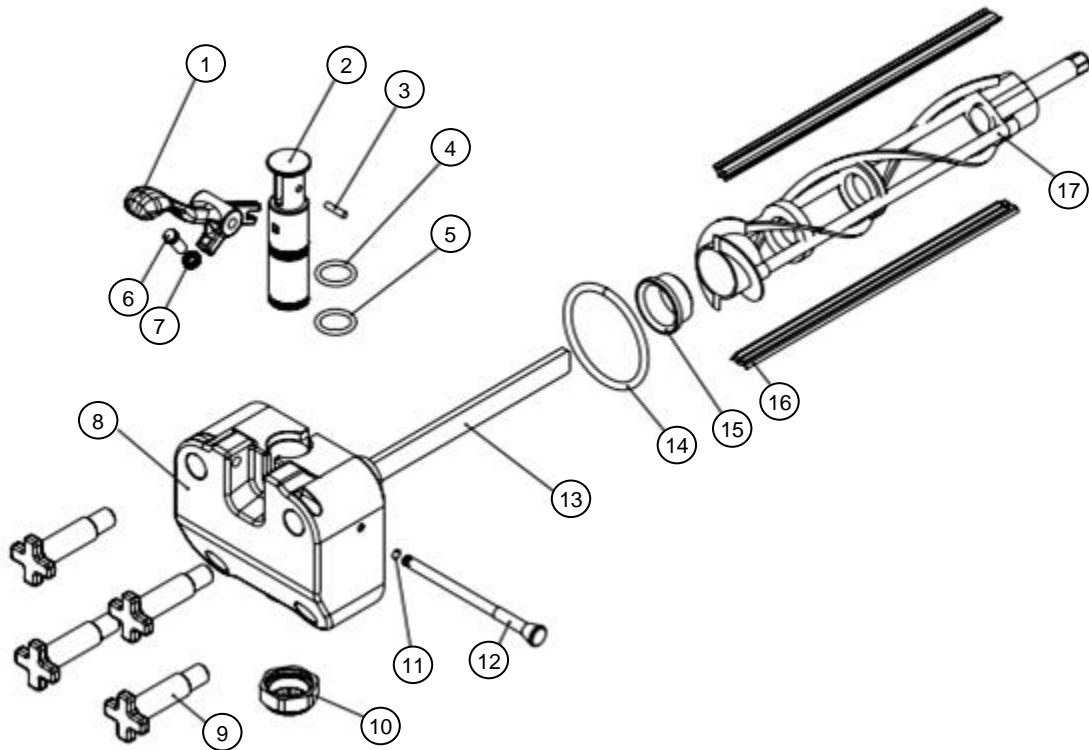

Figure 66

ITEM	DESCRIPTION	Part No.
1	Draw Handle	309005400
2	Draw Valve	303304600
3	Shaft - Pin	315002900
4	O-ring – Draw Valve, Upper	303039500
5	O-ring – Draw Valve, Lower	303041300
6	Screw - Adjustment	210818100
7	Hex Nut	215011000
8	Door – Freezing Cylinder	303018100
9	Nut - Stud	342004100

ITEM	DESCRIPTION	Part No.
10	Cap – Design	388008200
11	O-ring – Lever Shaft	303020000
12	Pin - Pivot	314040300
13	Baffle	314015601
14	Gasket - Door	303018100
15	Bearing – Door Hub	310003502
16	Scraper Blade	403015000
17	Beater	403022400

If the warranty is not registered through your distributor, or if it is hard to determine the date of purchase due to other reasons, warranty is applied after 6 months from the manufacturing date.

Free repair

1. Error in performance or functionality during normal operation before the warranty expires

Billable repair

1. If the warranty has expired.
2. If installation is required again due to incorrect installation by the customer or the store.
3. If installation is required again due to relocation of the machine.
4. If the malfunction is not attributable to the machine.
5. If the wrong power specification is applied.
6. If damage is caused by using accessories that are not recommended by the manufacturer.
7. If damage is caused by external force or dropping of the machine.
8. If damage is caused by natural disaster, such as lightning, fire, earthquake, storm, typhoon, etc.
9. If any accessory or consumable becomes obsolete or its service life comes to an end. (Gaskets, O-rings, blades, cleaning brushes, etc.)
10. If foreign objects are put into the machine such as water, beverage, coffee, toy, etc.
11. If external force is applied during installation or usage, causing damage or malfunction.
12. If directions for installation or standards are not followed.
13. If the customer arbitrarily disassembled and lost or damaged any part.
14. If a person other than an authorized engineer from your Taylor distributor repairs or modifies the machine.
15. If malfunction is caused by failure to follow the "Safety warning / caution" on the user manual.



ICETRO AMERICA, INC

