



FRIIA V2

Service Manual



Contact Details

Marco Beverage Systems Ltd. 74 Heather Road, Sandyford Industrial Estate, Dublin 18, Republic of Ireland	Ireland Tel: 00353 (0)1 295 2674
	UK Tel: 01933666488
	USA Tel: 206-641-7692
	China Tel: 206-641-7692
	UAE Tel: +971 52 4804242

Machine Part Numbers

IRL/UK/EU	US
1000050 FRIIA Cold Sparkling 230V	1001050US FRIIA Cold Sparkling 120V
1000051 FRIIA 230V	1001051US FRIIA Cold 120V
1000052 FRIIA Cold Sparkling 230V Standard	1001052US FRIIA Cold Sparkling 120V Standard
1000053 FRIIA Cold 230V Standard	1001053US FRIIA Cold 120V Standard

CONTENTS

1. INTRODUCTION	5
2. SAFETY INSTRUCTIONS	6
3. INSTALLATION DETAILS.....	6
3.1 Positioning.....	6
3.2 Electrical installation:	7
3.3 Plumbing installation procedure:.....	7
3.4 Backflow prevention	8
4. SPECIFICATION & RATING PLATE.....	9
4.1 Specification	9
4.2 Rating Plate Example.....	10
5. CO2 INSTALLATION	11
5.1 CO2.....	11
5.2 GAS CYLINDER LOCATION	11
5.3 PRESSURE REGULATOR	11
6. CABINET VENTILATION	12
7. CLEANING AND SANITISING.....	16
7.1 Daily Cleaning.....	16
7.2 Sanitising	16
8. REFIGERATION CIRCUIT SERVICE	19
9. MACHINE SETTINGS.....	19
9.1 Adjusting Set Temperature	19
9.2 ADDITIONAL: Pump Boost Function (Carbonated Version Only).....	20
9.3 ADDITIONAL: Turn Off Hot Safety Features	21
9.4 ADDITIONAL: Time Dispense Cold and Sparkling.....	22
10. INTERNAL ACCESS.....	23
10.1 Service Panel Removal	23
11. SERVICEABLE COMPONENT REMOVAL.....	24
11.1 Carbonation Pump	24
11.2 Dispense Solenoids (Cold, Sparkling & Ambient).....	24
11.3 Condenser Fan	25
11.4 Electronics	26
12. Troubleshooting	27
12.1 Carbonation pump	27

12.2	SAFETY PRECAUTIONS.....	27
12.3	LOW OR NO CO ₂ LEVELS IN BEVERAGE.....	27
	Possible Causes and Corrective Actions	27
12.4	COMPRESSOR RUNS CONTINUOUSLY, WATER NOT COLD	28
12.5	COMPRESSOR WILL NOT START	29
12.6	UNIT CHILLS BUT OPERATES CONTINUOUSLY OR NON-STOP	30
12.7	NO UNIT CHILLS BUT OPERATES CONTINUOUSLY OR NON-STOP	31
13.	Error Codes.....	32
13.1	Two font/chiller LED flashes (OFF/ RED).....	32
13.2	Three font/chiller LED flashes (OFF/ RED)	32
13.3	Four font/chiller LED flashes (OFF/ RED)	32
14.	ELECTRICAL SCHEMATICS	33
14.1	Wiring Diagrams.....	33
15.	PLUMBING DIAGRAMS	37
15.1	Plumbing Diagram.....	37
16.	INSTALL KITS	41
17.	SPARE PARTS.....	45
17.1	Spare Parts List.....	45

1. INTRODUCTION

The information provided in this manual is intended to assist in the installation and maintenance of the FRIIA Chiller & Chiller Carbonator. Please read the instructions carefully to prevent accidents and ensure efficient installation.

This manual is not a substitute for any safety instructions or technical data affixed to the machine or its packaging. All information in this manual is current at the time of publication and is subject to change without notice.

Only technicians or service providers authorised by Marco should carry out installation and maintenance of these machines.

Marco accepts no responsibility for any damage or injury caused by incorrect or unreasonable installation and operation.

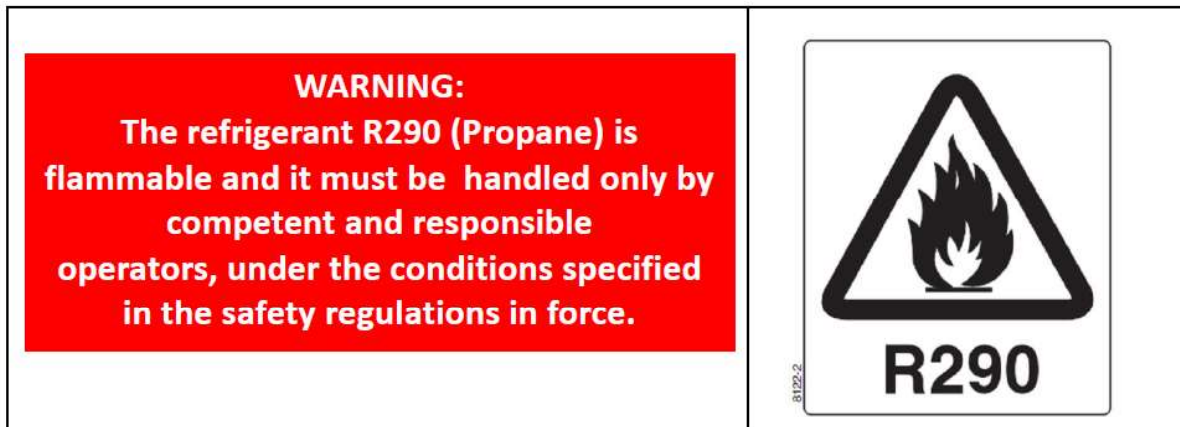

2. SAFETY INSTRUCTIONS

Read all instructions.

To protect against electric shock do not immerse mains cord in water or other liquid.

To prevent fraying of the cable, do not let the mains cord hang over the edge of a table or counter; or touch hot surfaces.

Do not operate any appliance with a damaged cord, plugs, or after the appliance malfunctions or has been damaged in any manner.

Switch off at the mains (unplug or disconnect from outlet) and turn off the water supply when not in use and before cleaning. Allow to cool before removing components.

The use of spares and accessories not recommended by Marco may cause damage and/or injuries.

Do not use outdoors. Do not place on or near a hot gas or electric burner.

Do not use the appliance for anything other than its intended use.

Save these instructions.

3. INSTALLATION DETAILS

3.1 Positioning

The equipment must be placed on a surface capable of bearing the weight of the chiller complete with water. Install the equipment following the schematic described in this user guide.

The chosen position must in any case allow satisfactory ventilation; in particular, there must be a gap of at least 10 cm (3.9 in) around the back and top for ventilation.

The equipment must not be placed close to direct or indirect heat sources (ovens, stoves, radiators, etc.).

The electrical connection and water supply points must be close to the equipment and located in such a way the power cable and water hose do not form an obstruction.

The appliance must not be installed where water jets can be generated. Do not spray water on the device; this could cause electric shock or fires.

3.2 Electrical installation:

Electrical specification: 380W 230V 50Hz/60Hz

Electrical specification US: 380W 110V 60Hz

A moulded IEC C19 power cord is provided. This should be plugged into the IEC connection on the back of the chiller, then plugged into a suitable power outlet.

A US 3 Pin (NEMA 515P) plug to C19 IEC is provided with the 110V chillers.

3.3 Plumbing installation procedure:

Mains water pressure not to exceed 5 Bar.

To ensure that the maximum value of pressure of 3 Bar is not exceeded the chiller integrates a pressure reducer.

Ensure that the equipment is installed according to local plumbing & water regulations.

Fit a stop valve on the 3/8" cold water line.

Make sure the pipe is pushed fully into the fitting; Make sure that, when required, the pre attached sealing washer is fitted.

Turn on the water to flush any impurities, dust etc from the inlet hose and water pipe. Allow several litres through. Especially for new installations.

Connect water supply lines following the installation drawings.

If the filter is new, turn on water and flush at least 10 litres (2.5 gallon) through the filter before connecting it to the cooler.

Connect the 3/8" hose to the inlet elbow of the chiller. Make sure the pipe is pushed fully into the fitting.

Turn on water and check for leaks.

3.4 Backflow prevention

This equipment must be installed with adequate backflow prevention to comply with all applicable federal, state and local codes.

EU Machine is supplied with already integrates a dual backflow prevention device with a dedicated 100 mesh strainer (see spare parts list for details).

NSF compliant version already integrates a dual backflow prevention device ASSE1032 certified with a dedicated 100 mesh strainer (see spare parts list for details).

4. SPECIFICATION & RATING PLATE

4.1 Specification

Performance	Total Hourly output (L/hr)	30-35	
	Carbonation tank Volume	1L	
Electrical	Mains Connection	BS1363 (IRL&UK) & CEE7 (EU)plug to C19 IEC	NEMA 515P plug to C19 IEC
	Rating	380W 230V 50Hz/60Hz	380W 110V 60Hz
Plumbing	Fittings	Fit a stop valve on the 3/8" cold water line	
	Required Pressure	Mains water pressure not to exceed 5 Bar.	
Dimensions	Height (mm)	561	
	Width (mm)	407	
	Depth (mm)	614	
Weight	kg	35 kg	
Refrigerant	R290	70g	

4.2 Rating Plate Example

EU/UK Example

MODEL: 1000050 FRIIA V2 Cold Sparkling	
SERIAL NO: 0123456789	
230V 50/60Hz 380W 1.65A	
Refrigerant : R290 70g (2.47oz)	
Pressure : Low 410kPa High 1553kPa	
WATER INLET PRESSURE MIN-MAX	
0.1-1MPa (14.5-145psi)	
MARCO BEVERAGE SYSTEMS LTD.	
www.marco.ie	

US Example

MODEL: 1001050US FRIIA V2 Cold Sparkling US	
SERIAL NO: 0123456789	
120V 60Hz 380W 3.2 A	
Refrigerant : R290 70g (2.47oz)	
Pressure : Low 410kPa High 1553kPa	
WATER INLET PRESSURE MIN-MAX	
0.1-1MPa (14.5-145psi)	
MARCO BEVERAGE SYSTEMS LTD.	
www.marco.ie	

Power & Voltage EU/UK – 230V 50/60Hz 380W 1.65A

Power & Voltage US – 120V 60Hz 380W 3.2A

Refrigerant – R290 70g (2.47oz)

Refrigerant Low Pressure Side – 410kPa

Refrigerant High Pressure Side – 1553kPa

Water Inlet Pressure (Min-Max) - 0.1 – 1 MPa (14.5 – 145 psi)

5. CO2 INSTALLATION

5.1 CO2

Connect CO2 using the appropriate 8mm polyethylene tube.

Only use super-dry food grade CO2. Before connecting the pressure reducer to the gas cylinder, always vent any dirt from the valve and close the cylinder valve after few seconds.

5.2 GAS CYLINDER LOCATION

To prevent the risk of injury or damage, the CO2 cylinder must always be kept in a vertical position against a wall, held in place by a chain and fixed to a bracket. Do not expose the bottle to heat sources or very low temperatures.

5.3 PRESSURE REGULATOR

There are different type of CO2 cylinder available. Always use a pressure regulator suitable for the type of valve on the cylinder.

Please use dual gauge CO2 regulator PN 1400195 (EU) and 1400196 (US).

Check for leaks using a solution of soapy water.

If you have a CO2 leak, ventilate the contaminated area at once.

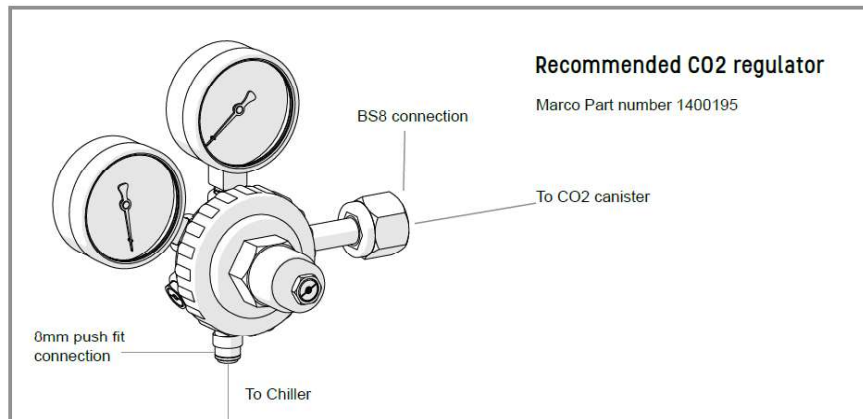

1400196 (EU) -Dual Gauge CO2 Regulator 4.8bar (BS341 No8 (0.860" x 14tpi))

1400195 (US) -Dual Gauge CO2 Regulator 4.8bar US (CGA 320 thread)

IMPORTANT!

For correct operation, chilling function and to ensure longevity of the components within the chiller please ensure the internal cabinet temperature does not exceed 35°C (95°F).

Each chiller can run two 24V DC fans that can be attached to a cabinet wall for better ventilation (details below)

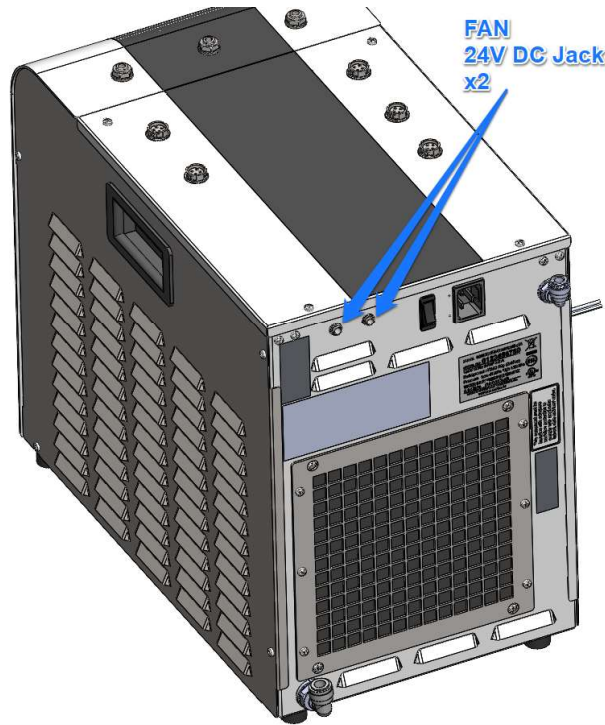

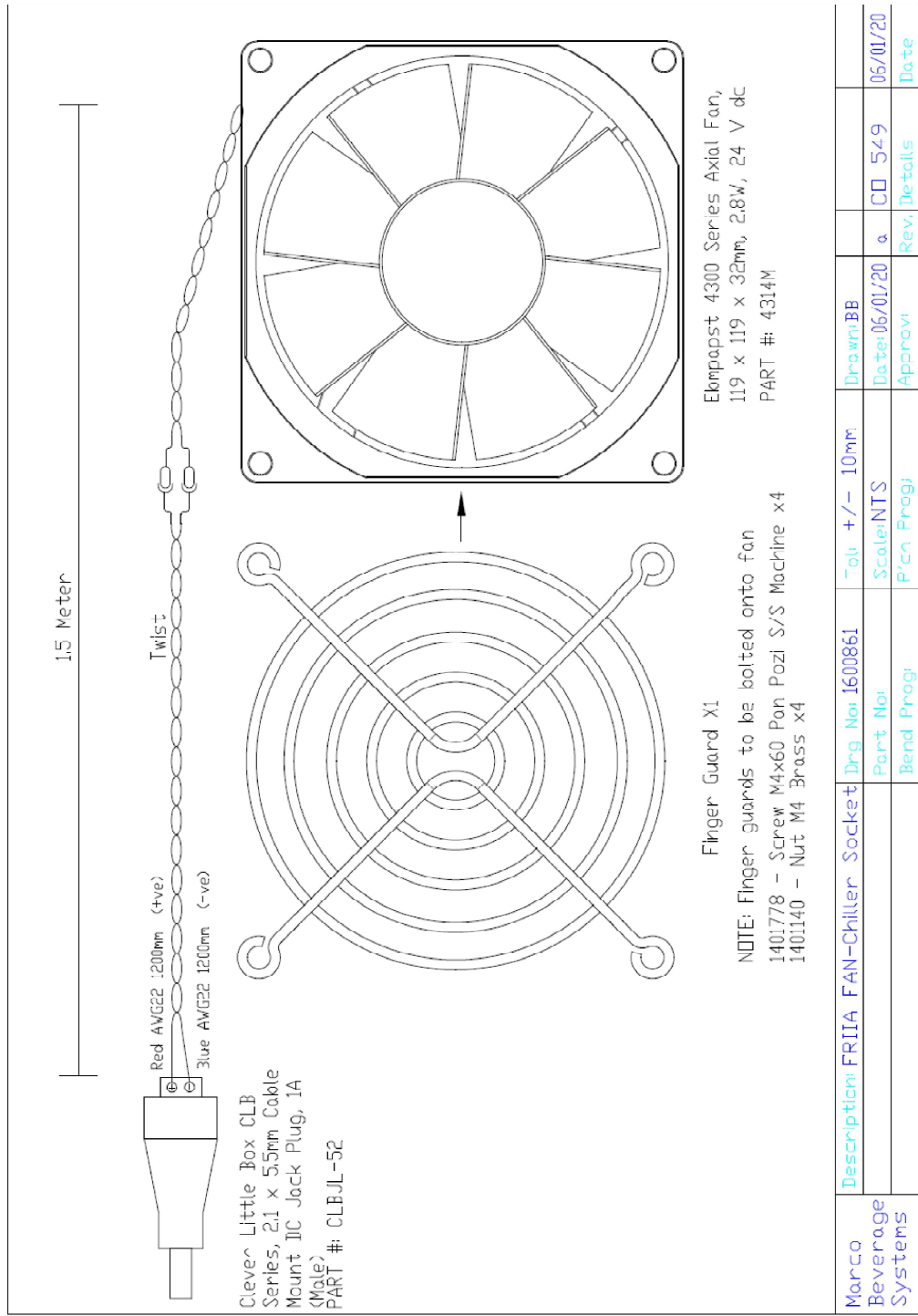

Accessories	
Part Number	Description
1600861	FRIIA Fan Assembly (chiller socket)
1860389	Cabinet Grille 300x80mm

Cabinet Ventilation

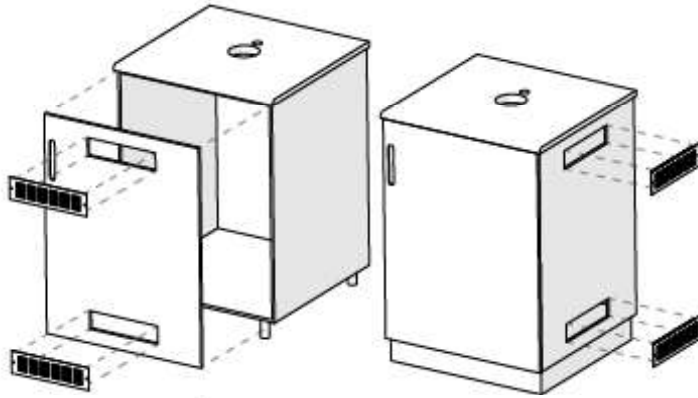

Front ventilation

Ventilation grilles cut out of standard cabinet door.

Side ventilation

Ventilation grilles cut out of standard 600mm cabinet. Grilles may be fitted on either side as long as they ventilate into an open unobstructed area.

Please Note:

In all cases remove the back panel from the cabinet.

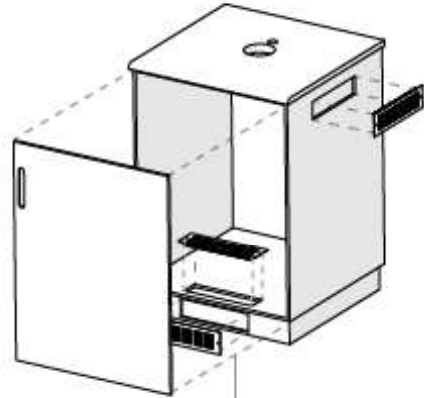

Base ventilation

Ventilation grilles cut in base panel and base plinth, a grille must also be cut out at the top of the cabinet.

The cabinet may be ventilated in many ways provided there are cut outs placed near the base and another near the top of the cabinet to take advantage of natural circulation.

Cabinet temperature: Max 35°C, if more air is not being evacuated efficiently it may cause cooling issues or possibly damage the equipment.

Grille dimensions

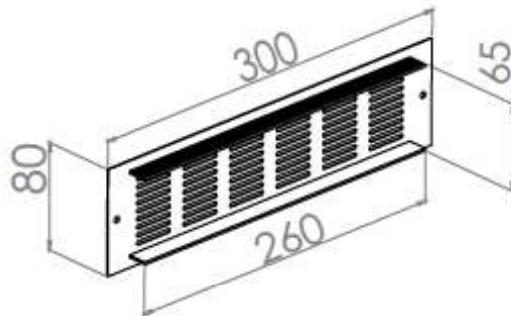

Cut out for standard 600mm door

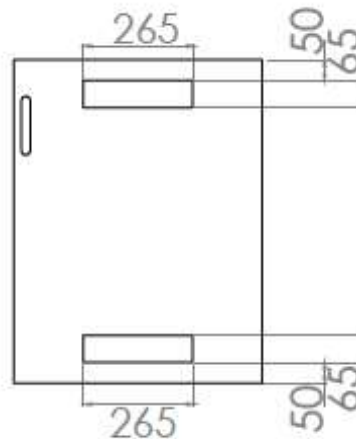

Fan Installation

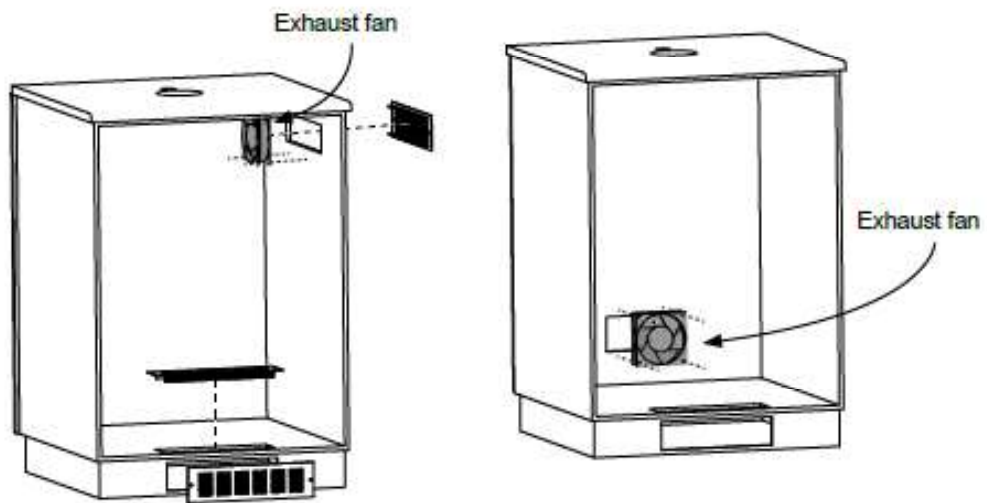
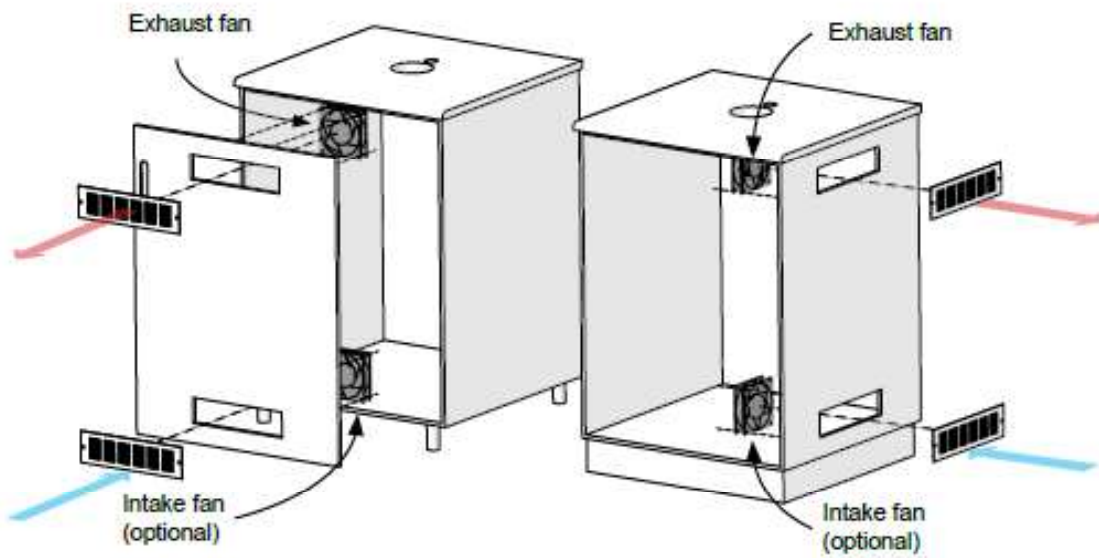

7. CLEANING AND SANITISING

7.1 Daily Cleaning

Water font

Clean the font nozzle and remove any residual using warm water do not use solvents or abrasive detergents If needed, remove all the limestone with a food descaling solution

Drip tray

Clean the drip tray and remove any residual using warm water

Chiller

The exterior of these machines may be cleaned with a damp cloth and a light detergent. Do not use abrasive cloths or creams, as this will spoil the finish of the machine Do not use a water jet or spray

Chiller Condenser

Check the chiller condenser at regular time intervals, in accordance to environmental conditions (humidity and dust).

If dust or dirt accumulates between the condenser blades, remove stainless steel cover and clean condenser fins using a soft brush, a vacuum cleaner or low pressure compressed air.

Remove any dust from the cooling and electrical components.

Accumulation of dust and grease over the condenser may cause overheating, and this in turn could damage the compressor beyond repair

The condenser must always be cleaned when necessary

Do not use wire brushes and compressed air jets because they can damage condenser fins.

7.2 Sanitising

CAUTION!

Before carrying out the following operations, carefully read the instructions given by the sanitization product manufacturer and make sure all personal protective equipment (masks, gloves, etc) are worn correctly. The sanitization of the product lines must only be carried out by specialized technical service personnel. During the sanitization operations, attach a warning sign to the tower concerned, to inform any other personnel that this operation is in progress, and that it is forbidden to dispense beverages.

1900026 – Marco Sanitising Kit



1900026 Kit Parts		
8000522	Chiller Best Service Cartridge (with screw top)	1
8000700	Filter bestmax head	1
1400833	3/8 BSPF - 3/8" Pushfit (John Guest)	2
1400834	3/8" Tube LLDPE (John Guest)	0.5m

This procedure should only be carried out by people trained by Marco Beverage Systems or their approved distributors.

The operation of sanitation must be carried out every time the chiller is installed and

- every 6 months when it is used
- every time the water filter is changed
- after an inoperative period of one or more weeks

If the refrigerator is installed in Hospitals, Schools, Elderly people’s homes, or Clinics, it is recommended to sterilize it every 3 months

Use a suitable product that is both a detergent and a sanitizer, to be mixed with water in the proportions recommended by the manufacturer.

Marco Beverage Systems recommend **Bioguard Internal Water Cooler Sanitiser** We suggest changing the product type on a regular basis too, to prevent resistant bacteria from becoming established.

Never exceed the contact times and maximum dosage concentrations recommended by the manufacturer. Once the sanitizing fluid has flowed through and cleaned the lines, they must be thoroughly rinsed with mains water until all the sanitizer has been completely eliminated. Check the pH of the outlet water is the same as the pH of the inlet water (use litmus paper or a pH meter).

PREPARE THE COOLER FOR THE SANITIZATION

1. Turn on water and flush at least 4 litres (1 gallon) through entire system (still and carbonated water circuits)
2. Uncouple water line from main water supply
3. Dispense still water until it stops dispensing
4. Dispense carbonated water until CO₂ only comes out
5. Close the CO₂ cylinder and dispense carbonated water to remove CO₂ pressure completely.

SANITIZING

1. Turn off Electrical Power Supply
2. Replace the filter cartridge with a sanitizing cartridge (8000522) recommended by Marco Beverage Systems and fill with clean water and with sanitizing fluid in the concentration and contact time recommended by the manufacturer
3. Disconnect the water connections and connect them to the sanitization cartridge
4. Turn on water mains and Power Supply.
5. NOTE: Container and drain basin will be required to collect water from the font
6. Flush all lines (Cold and Sparkling) with sanitiser until you can see or smell the sanitizing product which may have a characteristic smell, or see the colour of the liquid (in the case of coloured products), or using colorimetric test strips, to be sure the entire line is filled with the sanitizing liquid
7. Alternate the dispensing operations every 15 seconds, respecting the maximum product usage time recommended by the manufacturer (failure to respect the exposure time may cause damage to the system)
8. Remove sanitizing cartridge (8000522).
9. Reconnect chiller to regular water supply
10. Return temperature adjustment knob to its original position
11. Flush the lines with mains water

8. REFRIGERATION CIRCUIT SERVICE

IMPORTANT!

Only Marco technicians or service providers trained on procedures for handling R290 refrigerant gas can carry out repairs on the chillers charged with R290. Please contact Marco before attempting any service repairs

R290 Service Overview

It is propane, so it is flammable. You MUST observe caution and proper safety practices when servicing R290 refrigeration systems.

Servicing refers to making repairs to the hermetically sealed system and any part of the electrical system. The EPA and UE set a limit, 150 grams/ 5.29 ounces, on the amount of R290 charge for commercial applications.

Repair on R290 systems must always be done in a well-ventilated area.

Because R290 is highly flammable, a combustible gas leak detector is required when servicing R290 systems.

9. MACHINE SETTINGS

9.1 Adjusting Set Temperature

The set temperature of the unit is controlled by three DIP switches (DIP 1, DIP 2, DIP 3) located on the control board. The temperature is adjusted by changing the ON/OFF position of these switches.

Adjustment Procedure:

1. Disconnect electrical power to the unit before accessing the control board.
2. Locate the DIP switch bank on the controller.
3. Set DIP switches 1-3 to the required ON/Off positions according to the desired temperature.
4. Restore power to the unit.
5. Allow sufficient time for the system to stabilise at the new set temperature.

DIP Switch Temperature Settings:

DIP Switch Temp Settings			
DIP 1	DIP 2	DIP 3	Set Temperature °C
OFF	OFF	OFF	1
OFF	OFF	ON	1.5
OFF	ON	OFF	2
OFF	ON	ON	2.5
ON	OFF	OFF	3
ON	OFF	ON	3.5
ON	ON	OFF	4
ON	ON	ON	4.5

Notes:

The factory default temperature setting is 2°C.

Lower temperature setting increases cooling demand and may increase compressor run time.

9.2 ADDITIONAL: Pump Boost Function (Carbonated Version Only)

The unit is equipped with a flow rate boost function that allows the operator to temporarily increase the dispense flow rate for cold and ambient water only. Sparkling water dispense is not affected by this function.

Procedure:

1. Press and hold the pushbutton on the printed circuit (PC) board.
2. The dispense font LED will begin to flash, indicating that the flow rate boost mode is active.
3. Continue holding the button to cycle through the available boost levels.
4. Release the button at the desired boost level.

Flow Rate Boost Levels:

- 2 seconds: 33% – *Slow*
- 4 seconds: 66% – *Medium*
- 6 seconds: 100% – *High*
- 8 seconds or longer: 0% boost – *Off (boost disabled)*

The boost level increases progressively the longer the button is held. After 8 seconds, the boost function resets to Off.

Notes:

- Flow rate boost applies to cold and ambient dispense only.
- Sparkling water dispense is unaffected by this setting.
- LED flashing speed increases as the boost level increases, providing visual feedback during adjustment.

Font LED Status During System Cool-Down

When the unit is powered on and has not yet reached operating temperature, the font LEDs indicate availability as follows:

- Font 1 and Font 2 LEDs: OFF
 - Cold and sparkling water dispense are unavailable during this period.
- Font 3 LED: White
 - Ambient water is available and may be dispensed if required.

Cold and sparkling dispense will become available automatically once the unit reaches the correct operating temperature.

9.3 ADDITIONAL: Turn Off Hot Safety Features

This feature is enabled by default to reduce the risk of accidental dispensing. When enabled, hot water dispense requires a double press of the hot water front button. When disabled, hot water will dispense with a single press.

Adjustment Procedure:

1. Ensure the unit is powered on.
2. Press the PCB control button to enter hot water safety adjustment mode.
3. The front LEDs will begin to flash white and red, indicating the unit is ready for configuration.
4. Press and hold the hot water front button corresponding to the outlet you wish to configure.
5. Observe the LED colour to confirm the setting:
 - 5.1. White LED: Hot water safety feature DISABLED (single-press dispense)
 - 5.2. Red LED: Hot water safety feature ENABLED (double-press dispense)
6. Release the button once the desired setting is displayed.
7. The unit will store the setting automatically.

Notes:

This setting applies only to hot water dispense.

LED colour provides immediate confirmation of the selected safety mode.

Changes take effect immediately; no power cycle is required.

9.4 ADDITIONAL: Time Dispense Cold and Sparkling

The unit supports a time dispense function, where pressing a dispense button opens the corresponding solenoid for a pre-set duration. The maximum programmable dispense time is up to 1 minute.

Time dispense is configured individually for each applicable font.

Configuration Procedure:

1. Enter Calibration Mode. Press the PCB button. The font LEDs will begin to flash white/red, indicating calibration mode is active.
2. Set Dispense Time. Press and hold the desired font dispense button (hot dispense is not applicable). Water will dispense while the button is held. Continue holding the button for the required dispense duration.
3. Save the Setting. Release the font button. The held duration is automatically stored as the time dispense setting for that font.
4. Exit Calibration Mode. Press the PCB button again to exit calibration mode and return to normal operation.

Disable Time Dispense

If a font dispense button is pressed for less than 0.5 seconds during setup, the time dispense function is disabled for that font.

Notes:

Maximum programmable dispense time is 60 seconds.

Time dispense applies only to non-hot fonts.

Each font can be programmed independently.

Ensure the unit is supplied with water during configuration, as water dispenses during setup.

10. INTERNAL ACCESS

Maintenance should be carried out by Marco approved technicians only.

10.1 Service Panel Removal

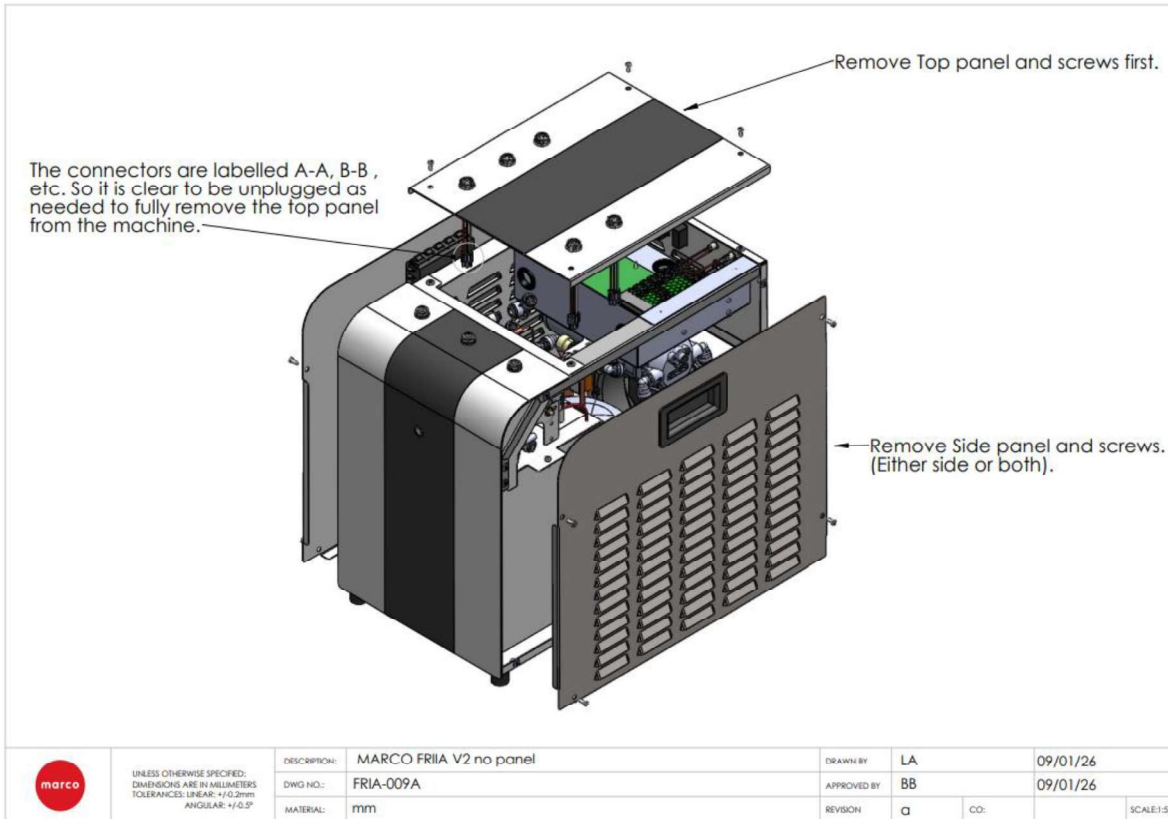

11. SERVICEABLE COMPONENT REMOVAL

11.1 Carbonation Pump

Loosen bolts (4x) to allow the pump plate to slide until the stud is aligned with the hole cutout.



DETAIL A
SCALE 2 : 5

The pump plate will release down, and be allowed to remove to the side.

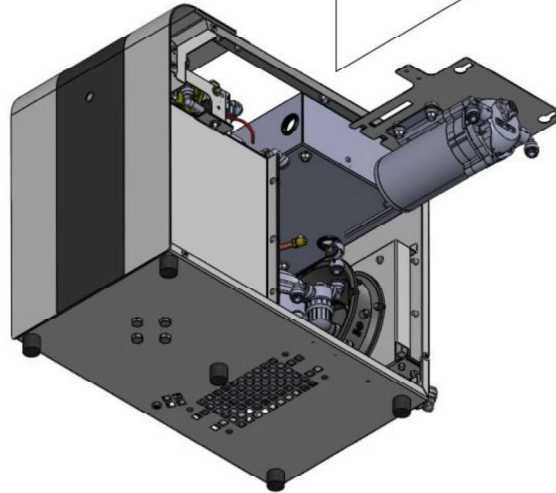
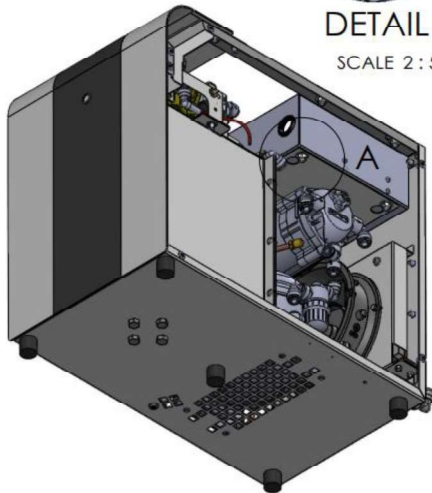

	UNLESS OTHERWISE SPECIFIED: DIMENSIONS ARE IN MILLIMETERS TOLERANCES: LINEAR: $\pm 0.2\text{mm}$ ANGULAR: $\pm 0.5^\circ$	DESCRIPTION: Marco FRIIA	DRAWN BY: LA	04/05/2024	
		DWG NO.: FRIA-011A	APPROVED BY: BB	04/05/2024	
		MATERIAL: mm	REVISION: a	CO:	SCALE:1

11.2 Dispense Solenoids (Cold, Sparkling & Ambient)

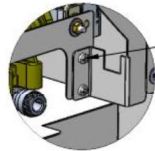

Unscrew the 2 screws to remove the solenoid mounted plate from the chiller.

DETAIL A
SCALE 2 : 5

Please ensure to carefully remove any tubing that may be connected.
* Potential leakage when tubing has residue water.

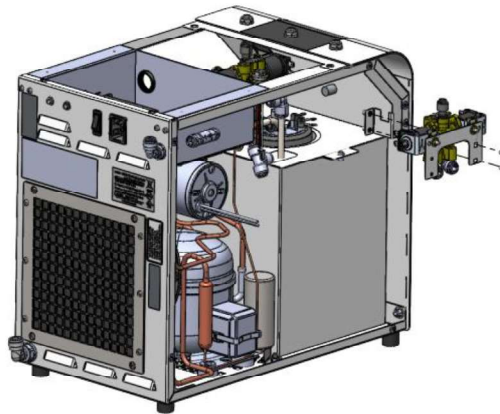
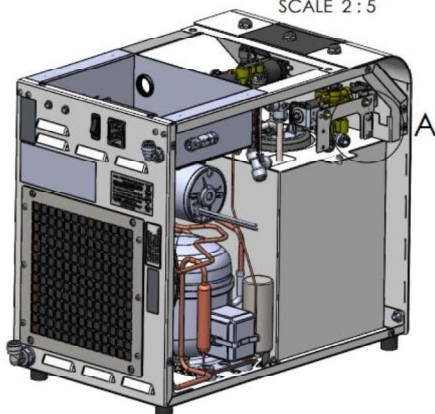

	UNLESS OTHERWISE SPECIFIED: DIMENSIONS ARE IN MILLIMETERS TOLERANCES: LINEAR: $\pm 0.2\text{mm}$ ANGULAR: $\pm 0.5^\circ$	DESCRIPTION: Marco FRIIA	DRAWN BY: LA	09/01/26	
		DWG NO.: FRIA-012A	APPROVED BY: BB	09/01/26	
		MATERIAL: mm	REVISION: a	CO:	SCALE:1.6

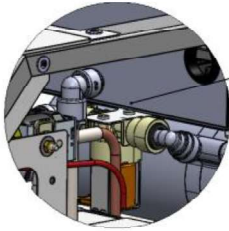

Unscrew screws from top(2x).

After the screws are removed, the solenoid will release for removal.
Please note some remaining water in tubes may leak when tubes are being disconnected.

DETAIL A
SCALE 2 : 5

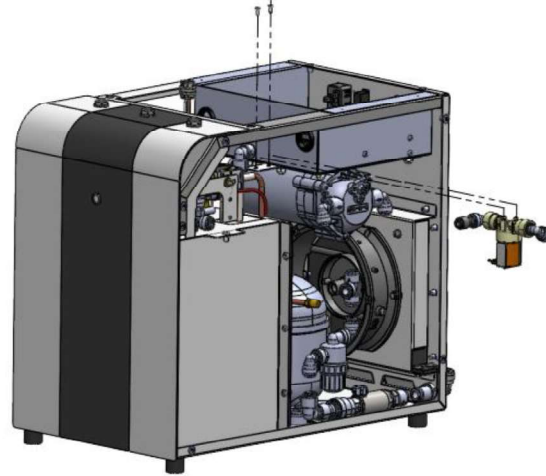
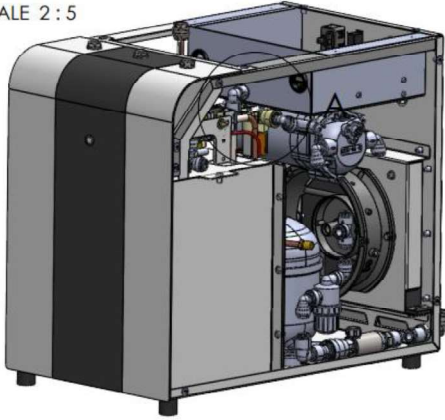

	UNLESS OTHERWISE SPECIFIED: DIMENSIONS ARE IN MILLIMETERS TOLERANCES: LINEAR: +/-0.2mm ANGULAR: +/-0.5°	DESCRIPTION:	Marco FRIIA	DRAWN BY:	LA	09/01/26	
		DWG NO.:	FRIA-013A	APPROVED BY:	BB	09/01/26	
		MATERIAL:	mm	REVISION:	a	CO:	
							SCALE:1:5

11.3 Condenser Fan

Unscrew M4 screws securing fan 4x.

DETAIL B
SCALE 2 : 5



The unsecured fan will be removable from either side without a panel.

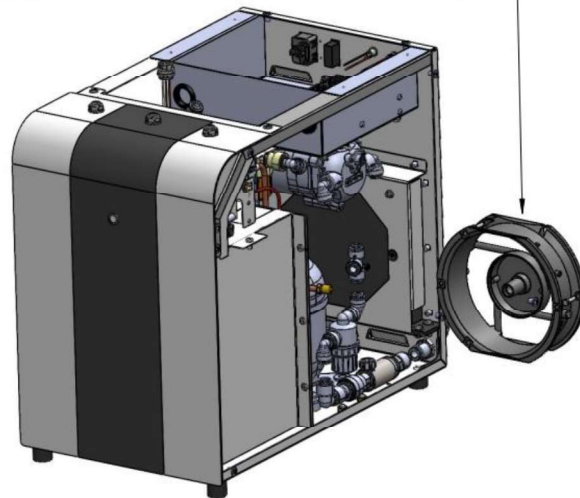
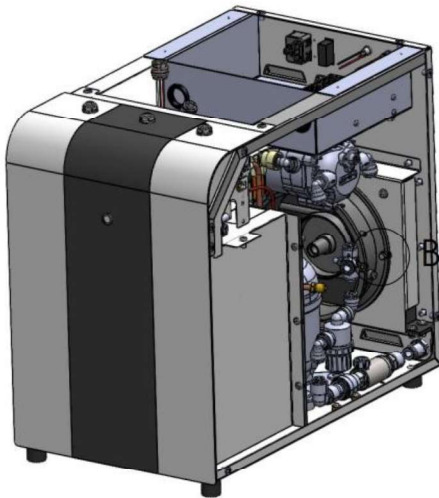

	UNLESS OTHERWISE SPECIFIED: DIMENSIONS ARE IN MILLIMETERS TOLERANCES: LINEAR: +/-0.2mm ANGULAR: +/-0.5°	DESCRIPTION:	Marco FRIIA V2	DRAWN BY:	LA	09/01/26	
		DWG NO.:	FRIA-010A	APPROVED BY:	BB	09/01/26	
		MATERIAL:	mm	REVISION:	a	CO:	
							SCALE:1:5

11.4 Electronics

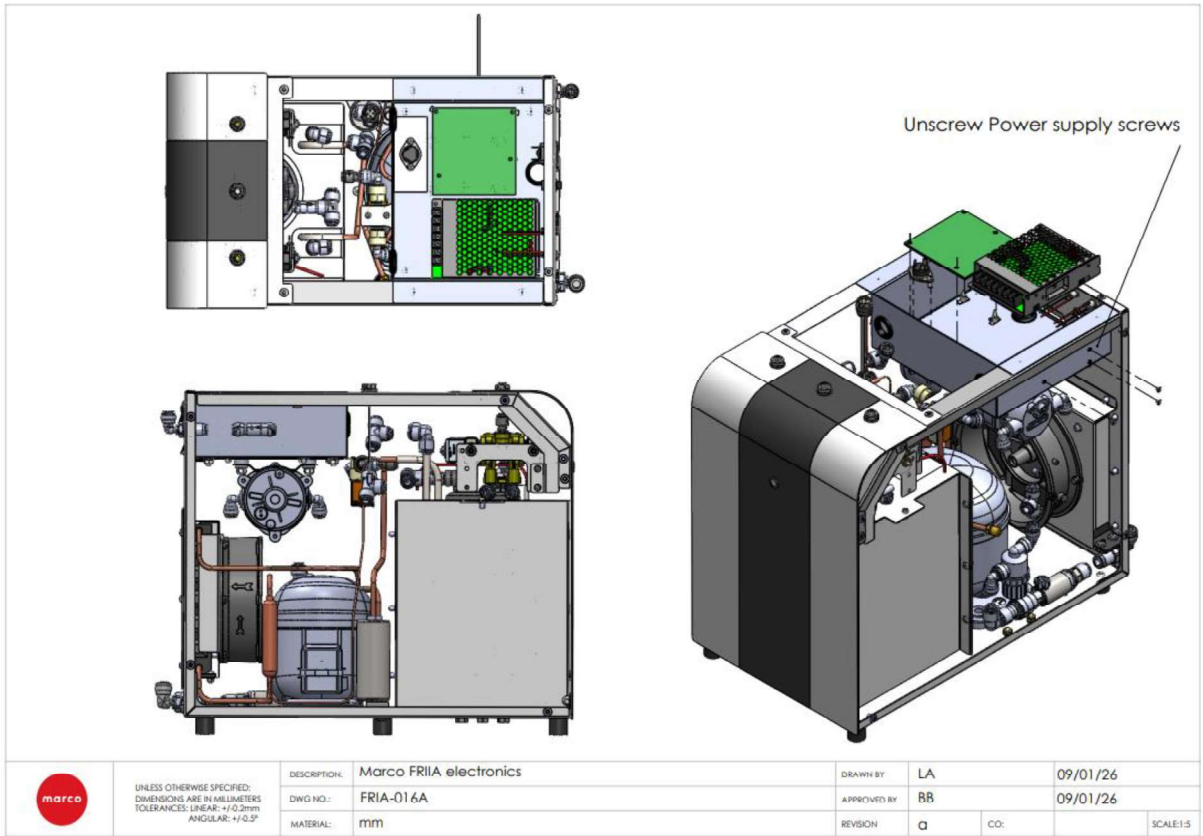

12. Troubleshooting

12.1 Carbonation pump

The device is equipped with a carbonation pump required for the addition of carbon dioxide in the water. After about 3.5 minutes of continuous operation, without the usual stops and starts dictated by the carbonation level probes (obvious symptom of leak of water in the feed), the pump shuts carbonation and the LED on the front of the chiller starts blinking. To reset this simply disconnect and then reconnect the power to the equipment.

12.2 SAFETY PRECAUTIONS

Disconnect electrical power before servicing electrical components.

Depressurize the CO₂ system before removing fittings or valves.

Allow compressor and condenser to cool before inspection.

12.3 LOW OR NO CO₂ LEVELS IN BEVERAGE

Possible Causes and Corrective Actions

➤ Low CO₂ Pressure

Condition: Beverage carbonation is weak.

Inspection	Corrective Action
Check CO ₂ regulator pressure gauge.	Restore CO ₂ pressure to 65–70 psi.

➤ No CO₂, Cylinder Empty

Condition: Beverage carbonation is absent.

Inspection	Corrective Action
Verify cylinder contents or weight.	Replace CO ₂ cylinder.

➤ Cooling Capacity Exceeded by High Usage

Condition: High draw volume over a short period.

Inspection	Corrective Action
Compare equipment specifications with usage volume.	Reduce number of drinks dispensed per time interval. Allow recovery time between high-demand periods.

➤ **Air Trapped Inside Carbonator**

Inspection	Corrective Action
Inspect carbonator for signs of air in system.	<ol style="list-style-type: none"> 1. Open carbonator vent check valve. 2. Pull vent ring until all air is purged.

➤ **CO₂ NRV Installed Incorrectly**

Inspection	Corrective Action
<ol style="list-style-type: none"> 1. Open left-side panel. 2. Locate non-return valve (NRV) after CO₂ inlet to chiller. 	Ensure arrow on NRV points in the direction of CO ₂ flow.

12.4 COMPRESSOR RUNS CONTINUOUSLY, WATER NOT COLD

Possible Causes and Corrective Actions

➤ **Gas Leak in Cooling System**

Inspection	Corrective Action
<ol style="list-style-type: none"> 1. Listen for hissing sounds. 2. Check fittings for frost or oil residue. 	Contact a certified refrigeration service technician or Marco Beverage Systems.

➤ **Faulty Compressor**

Inspection	Corrective Action
The compressor is not working.	Contact a certified refrigeration service technician or Marco Beverage Systems.

➤ **Poor Ventilation**

Inspection	Corrective Action
<ol style="list-style-type: none"> 1. Measure cabinet temperature. 2. Inspect condenser for dust or obstruction. 	<p>Ensure cabinet temperature does not exceed 35°C.</p> <p>Clear airflow obstructions around condenser.</p> <p>Allow compressor to cool; normal operation will resume automatically.</p>

12.5 COMPRESSOR WILL NOT START

Possible Causes and Corrective Actions

➤ Power Failure

Inspection	Corrective Action
1. Verify mains voltage at plug. 2. Check all electrical connectors.	Restore power and secure all connections.

➤ Faulty Thermistor

Inspection	Corrective Action
1. Inspect thermistor for visible damage. 2. Test resistance if applicable.	Replace thermistor if defective.

➤ Compressor Overload Protection Activated or Faulty

Inspection	Corrective Action
1. Check cabinet temperature. 2. Inspect condenser airflow.	Ensure cabinet temperature does not exceed 35°C. Remove condenser blockages. Allow compressor to cool; unit should reset automatically.

➤ Faulty Starting Relay or Capacitor

Inspection	Corrective Action
	Contact a certified refrigeration service technician or Marco Beverage Systems.

➤ Compressor Fault

Inspection	Corrective Action
	Contact a certified refrigeration service technician or Marco Beverage Systems.

12.6 UNIT CHILLS BUT OPERATES CONTINUOUSLY OR NON-STOP

Possible Causes and Corrective Actions

➤ **Poor Ventilation**

Inspection	Corrective Action
Check airflow around cabinet and condenser area.	Ensure adequate ventilation clearance is maintained around the unit.

➤ **Ambient Temperature Above Operating Limit**

Inspection	Corrective Action
Measure ambient temperature around the appliance.	Ensure ambient temperature does not exceed 35°C. Contact Marco Beverage Systems for cabinet ventilation guidance if required.

➤ **Blocked or Dirty Condenser Grills**

Inspection	Corrective Action
Inspect condenser grills for dust, grease, or obstructions.	Disconnect power to the unit. Clean condenser using a vacuum or dry cloth. Remove any obstructions restricting airflow.

12.7 NO UNIT CHILLS BUT OPERATES CONTINUOUSLY OR NON-STOP

Possible Causes and Corrective Actions

➤ Frozen Cooling Block

Inspection	Corrective Action
Check for ice formation restricting water flow.	Switch off the unit. Allow ice bank or water tubes to fully thaw. Reduce set temperature using DIP switch settings if applicable.

➤ Low or No Incoming Water Flow

Inspection	Corrective Action
Verify water supply is connected. Check stopcocks are fully open. Measure incoming water pressure.	Ensure stopcocks are fully open. Confirm inlet pressure is adequate for operation. Install a water booster pump if pressure is below 0.15 MPa.

13. Error Codes

The error codes displayed from the system.

13.1 Two font/chiller LED flashes (OFF/ RED)

Error Description	Potential Causes
Thermistor error, happens if the thermistor is open or short circuit.	<ul style="list-style-type: none">• Damaged thermistor harness.• Water splashes in the thermistor region of the PCB.• Rusted thermistor.• Lose connection in PCB.

13.2 Three font/chiller LED flashes (OFF/ RED)

Error Description	Potential Causes
Carbonation error happens when the carbonation pump runs for 2 minutes without filling the carbonation tank.	<ul style="list-style-type: none">• Insufficient inlet water pressure.• Damaged pump leads.• Incorrect DIP switch settings on a cold only machine.• Loose connection on the pump leads.

13.3 Four font/chiller LED flashes (OFF/ RED)

Error Description	Potential Causes
Refrigeration error happens when the refrigeration runs for 3 minutes, no cold/sparkling water has been dispensed but the temperature in the evaporator did not reduce	<ul style="list-style-type: none">• Refrigeration blockage.• Compressor failure.• Triac (compressor switching device) failure.• Condenser fan failure.• Insufficient R290 charge (due to leaks, etc).• Incorrect thermistor position.

14. ELECTRICAL SCHEMATICS

14.1 Wiring Diagrams

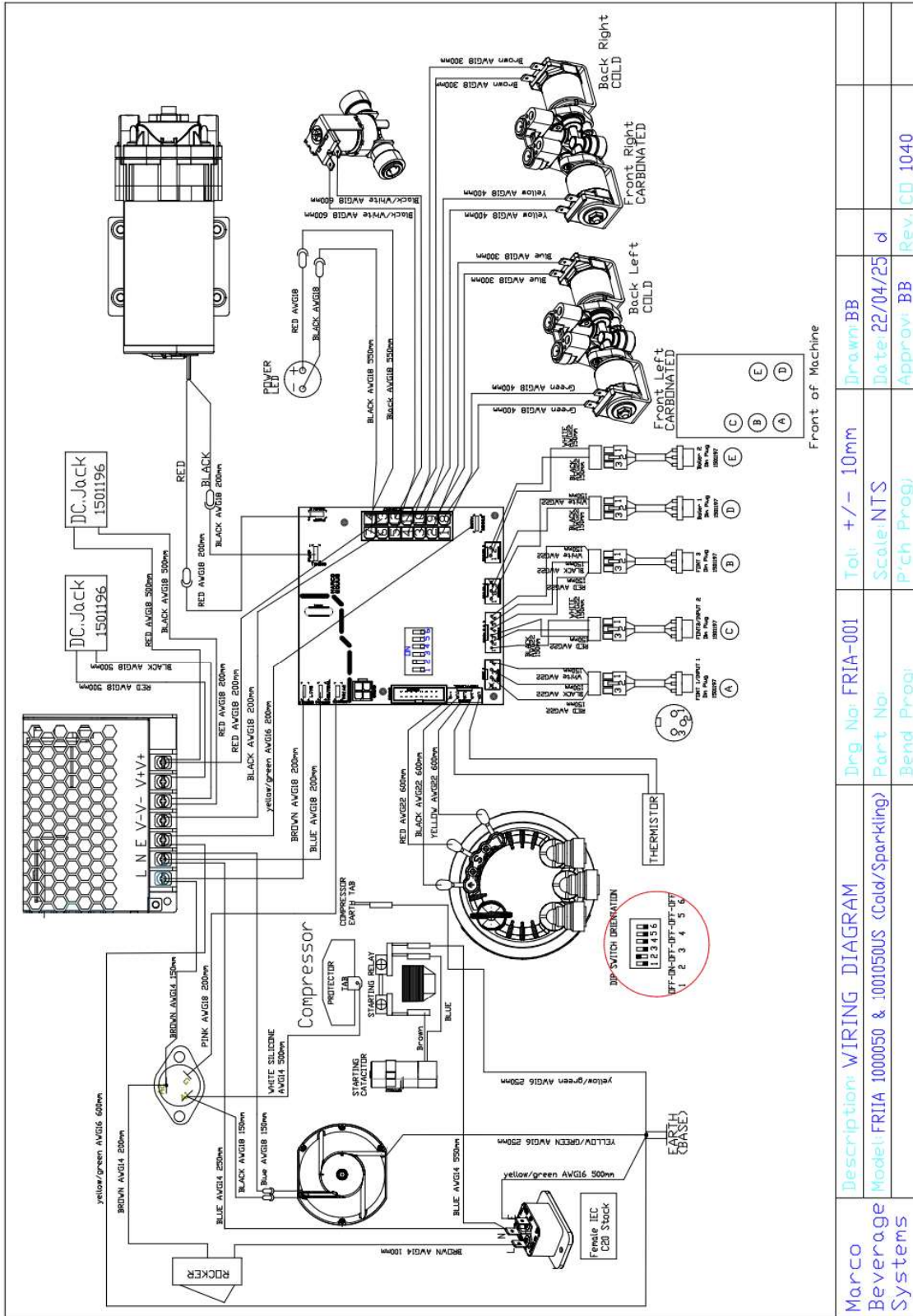

Marco Beverage Systems	Description: WIRING DIAGRAM	Drwg No: FRIA-001	Tol: +/- 10mm	Drawn: BB
	Model: FRIA 100050 & :001050US (Cold/Sparkling)	Part No:	Scale: NTS	Date: 22/04/25 d
		Bend Prog:	Prch Prog:	Approv: BB Rev: CD 1040

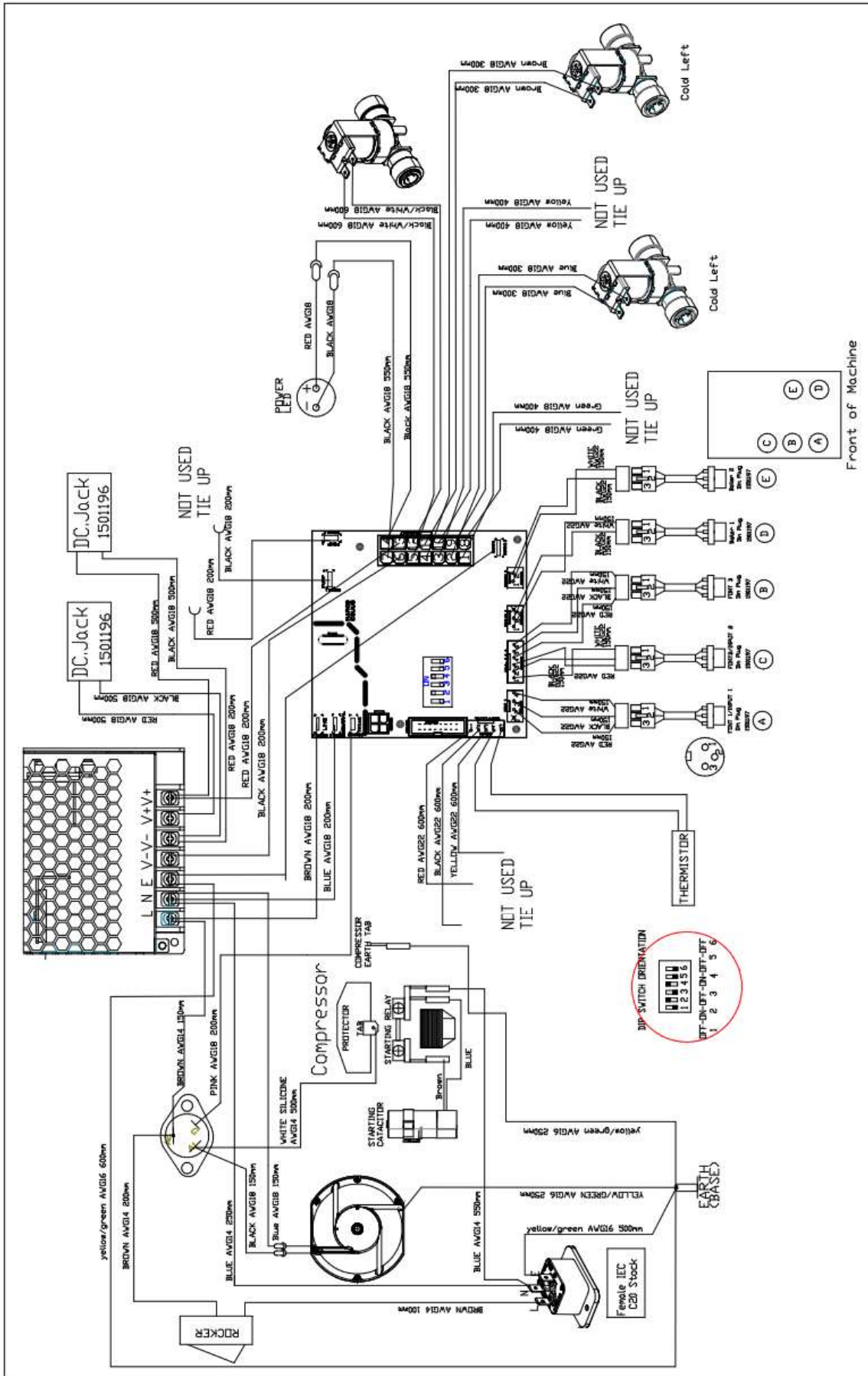

Marco Beverage Systems	Description: WIRING DIAGRAM	Dwg No: FRIA-003	Tol: +/- 10mm	Drawn: BB
	Model: 1000051 & 1001051US FRIA (COLD ONLY)	Part No:	Scale: NTS	Date: 22/04/25 c
		Bend Prog:	P'ch Prog:	Approv: BB
				Rev: CQ 1040

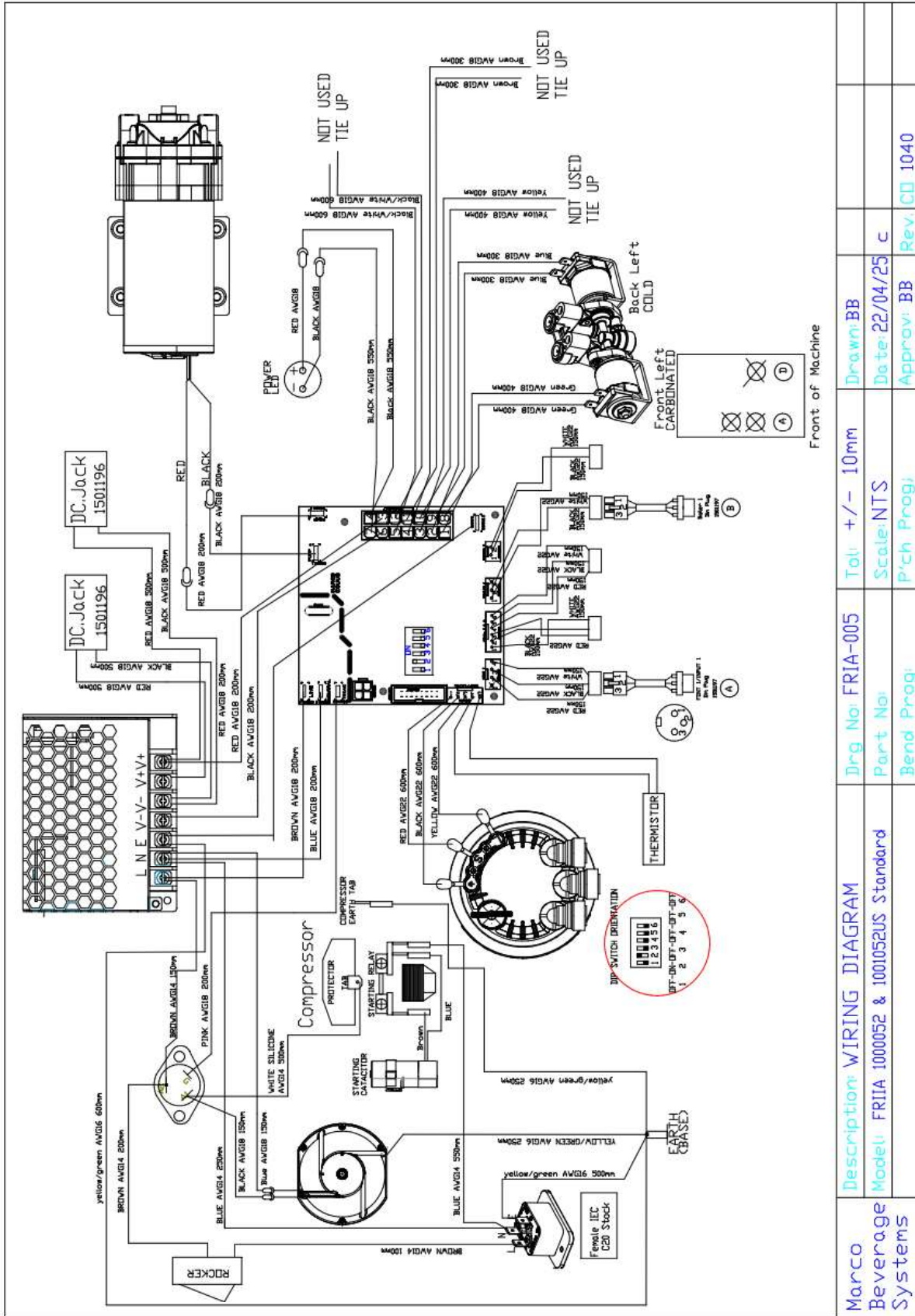

Marco Beverage Systems	Description: WIRING DIAGRAM	Dwg No: FRIA-005	Tol: +/- 10mm	Drawn: BB
	Model: FRIA 1000052 & 1001052US Standard	Part No:	Scale: NTS	Date: 22/04/25 c
		Bend Prog:	P'ch Prog:	Approv: BB
				Rev: CD 1040

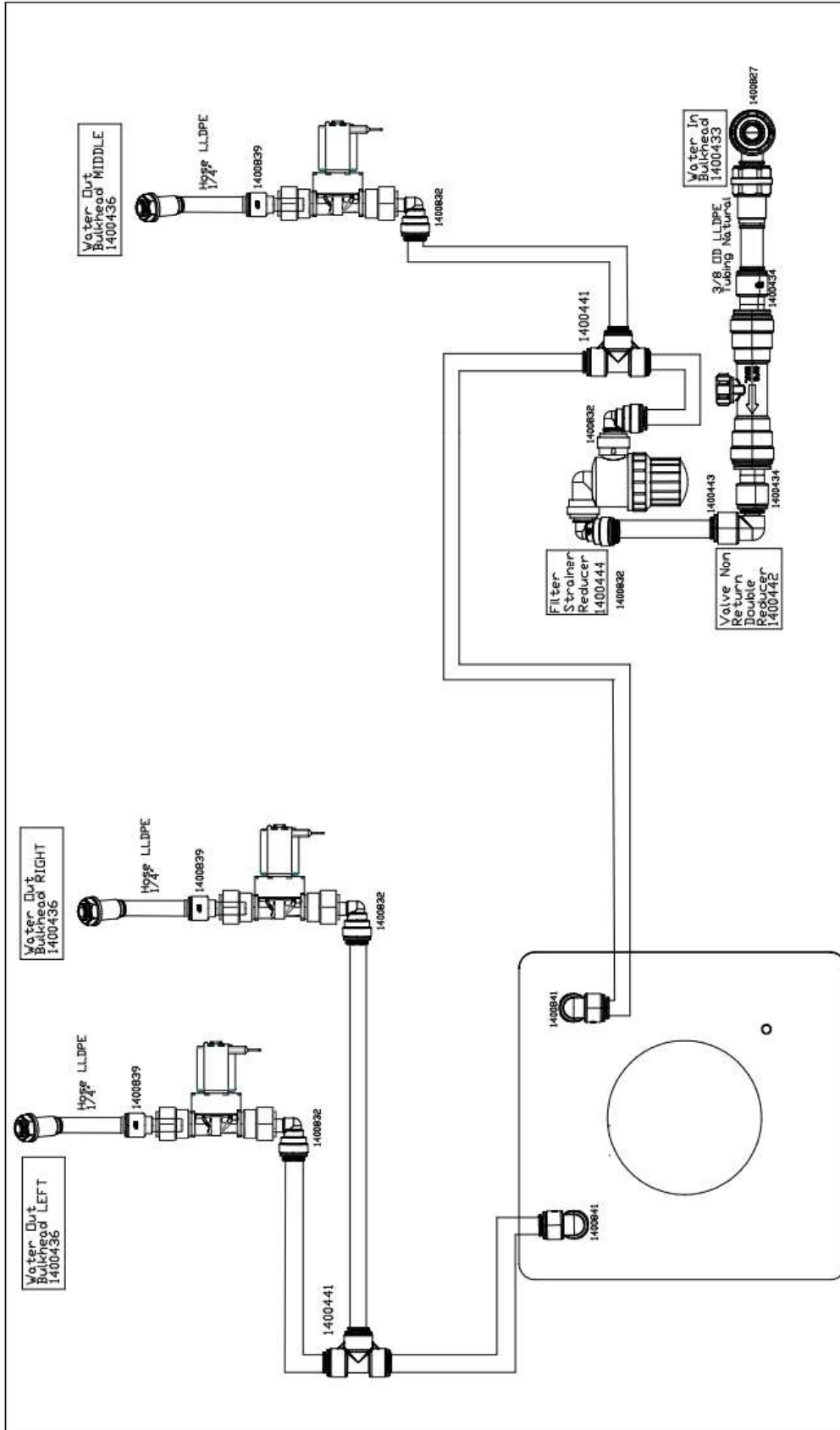

NOTE : ALL TUBE
8mm OD LLDPE Blue
Unless Otherwise Indicated

Marco Beverage Systems	Description: TUBING DIAGRAM	Drwg No: FRIA-004A	Tol: +/- 10mm	Drawn: BB
	Model: 1000051 & 1001051US FRIA (COLD ONLY)	Part No:	Scale: NTS	Date: 25/01/24
		Bend Prog:	P'ch Prog:	Approv:
				Rev: CO 899

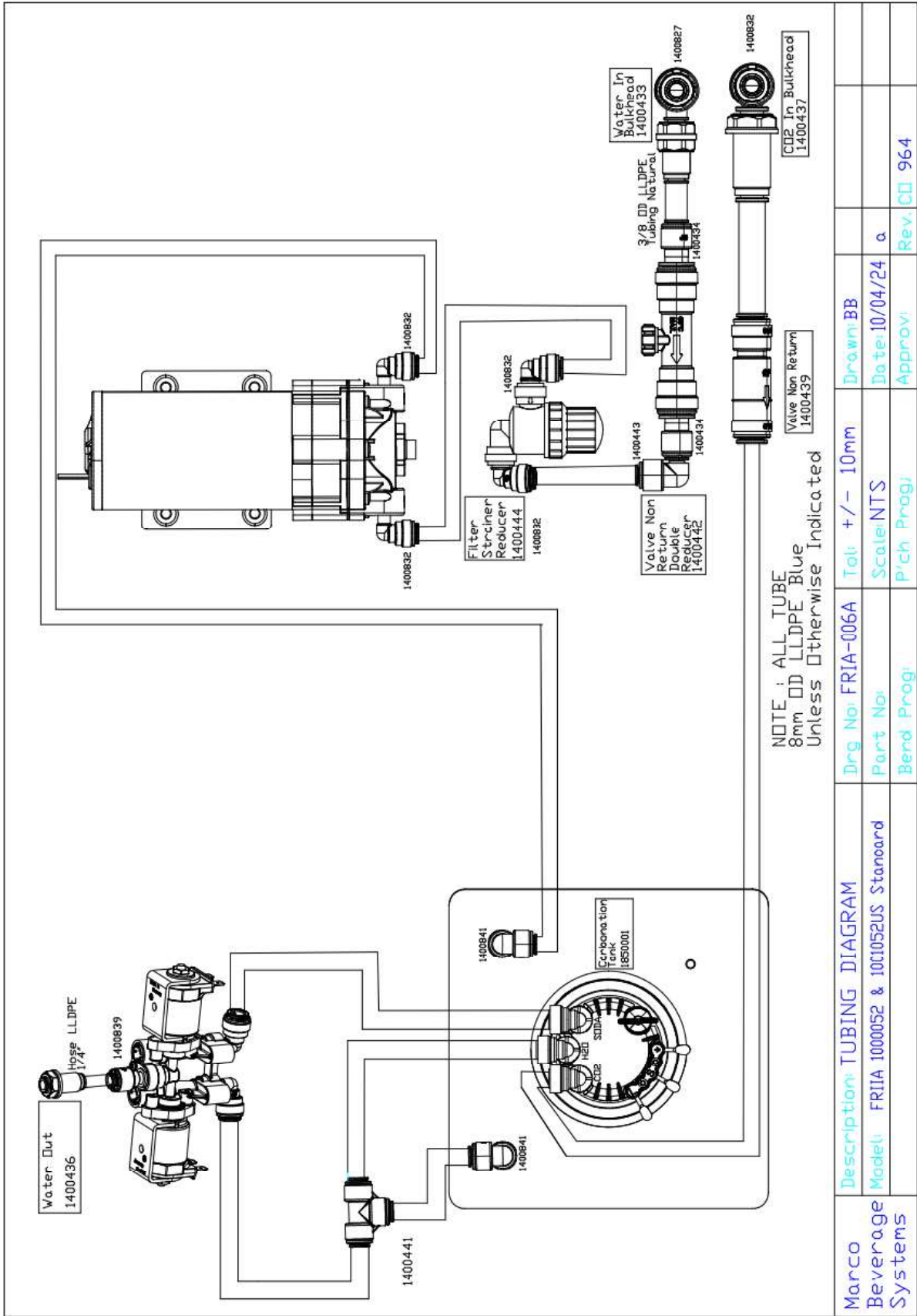

Marco Beverage Systems	Description: TUBING DIAGRAM	Drwg No: FRIA-006A	Tol: +/- 10mm	Drawn: BB	
	Model: FRIA 100052 & 1001052US Standard	Part No:	Scale: NTS	Date: 10/04/24	a
		Bend Prog:	P'ch Prog:	Approv:	Rev: CD 964

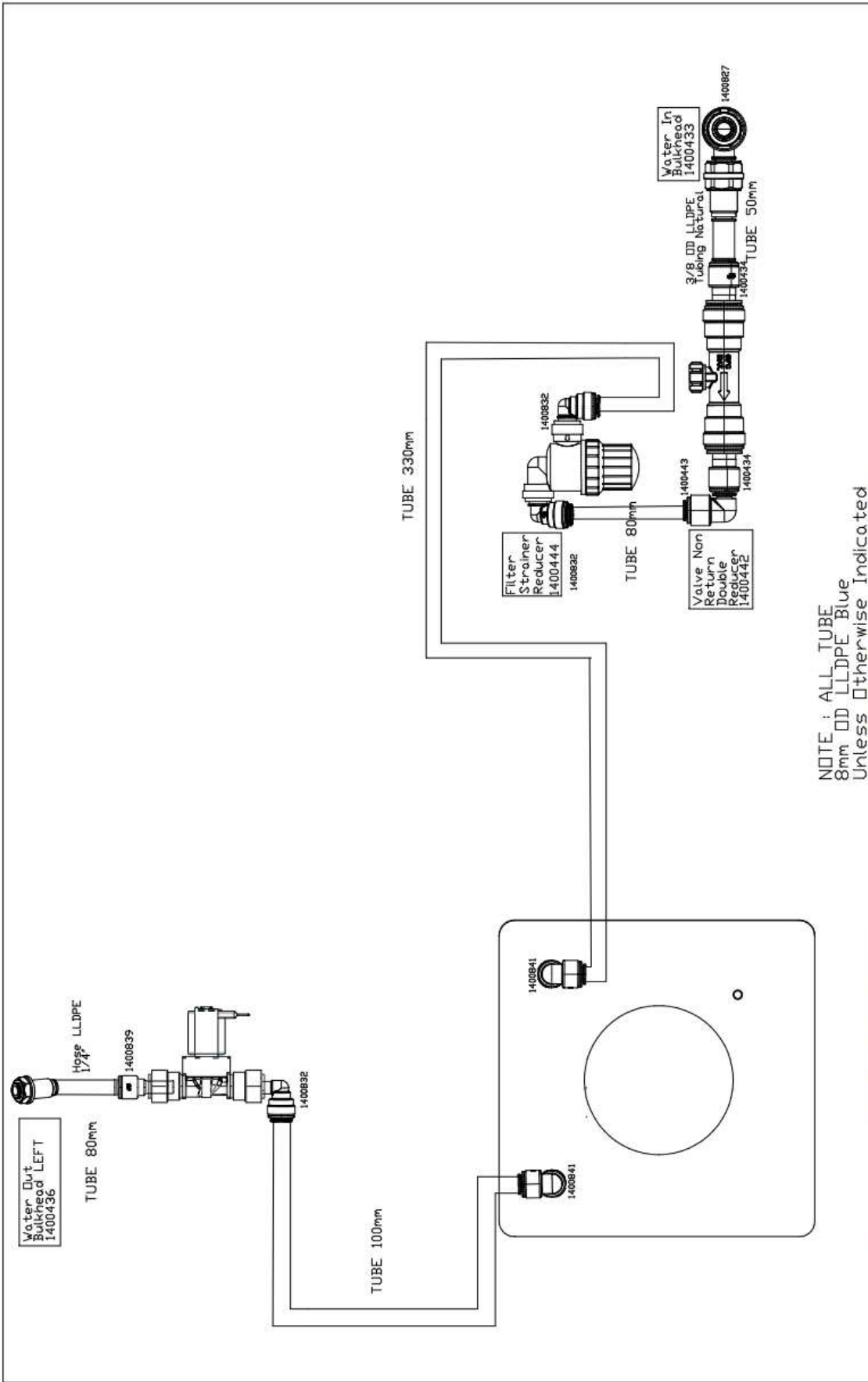









NOTE : ALL TUBE
 8mm OD LLDPE Blue
 Unless Otherwise Indicated







Marco Beverage Systems	Description: TUBING DIAGRAM	Drwg No: FRIA-008A	Tol: +/- 10mm	Drawn: BB
	Model: 1000053 & 1001053US FRIA Standard	Part No:	Scale: NTS	Date: 10/04/24
		Bend Prog:	P'ch Prog:	Approv:
				Rev: CD 964

16. INSTALL KITS









COLD/CARBONATED (EU/UK)

Part	Qty	Image	Marco PN
8mm Tube (CO2)	1.5M		1800628
3/8" Tube (water)	1.5M		1800627
Include John Guest 3/4" BSPF x 3/8" Push fit Adaptor (IN FITTINGS BAG)	2		1400822
Include 3/4" BSPM x 3/8" JG Pushfit (IN FITTINGS BAG)	1		1400823
Include 3/8" John Guest Y piece (IN FITTINGS BAG)	1		1400814
Boiler - chiller cable	1		1501180
User manual	1		1900007
Power Cable	1		1501489 (UK/IRL) 1501488 (EU)







COLD (EU/UK)

PartA2:D7A7A2:D8A2:D8A2A2:D9	Qty	Image	Marco PN
3/8" Tube (water)	1.5M		1800627
Include John Guest 3/4" BSPF x 3/8" Push fit Adaptor (IN FITTINGS BAG)	2		1400822
Include 3/4" BSPM x 3/8" JG Pushfit (IN FITTINGS BAG)	1		1400823
Include 3/8" John Guest Y piece (IN FITTINGS BAG)	1		1400814
Boiler - chiller cable	1		1501180
User manual	1		1900007
Power Cable	1		1501489 (UK/IRL) 1501488 (EU)

COLD/CARBONATED (US)

Part	Qty	Image	Marco PN
8mm Tube (CO2)	1.5M		1800628
3/8" Tube (water)	1.5M		1800627
Include John Guest 3/4" BSPF x 3/8" Push fit Adaptor (IN FITTINGS BAG)	2		1400822
Include 3/8" John Guest Y piece (IN FITTINGS BAG)	1		1400814
Include 5/16 (8mm) stem - 3/8" barb (PI251012S) (IN FITTINGS BAG)	1		1400773
Boiler - chiller cable	1		1501180
User manual	1		1900007
Power Cable	1		1501506









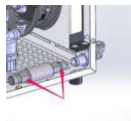

COLD (US)

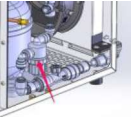
Part	Qty	Image	Marco PN
3/8" Tube (water)	1.5M		1800627
Include John Guest 3/4" BSPF x 3/8" Push fit Adaptor (IN FITTINGS BAG)	2		1400822
Include 3/8" John Guest Y piece (IN FITTINGS BAG)	1		1400814
Include 5/16 (8mm) stem - 3/8" barb (PI251012S) (IN FITTINGS BAG)	1		1400773
Boiler - chiller cable	1		1501180
User manual	1		1900007
Power Cable	1		1501506

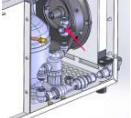

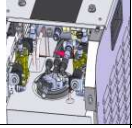

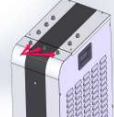

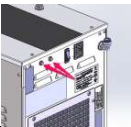

17. SPARE PARTS

17.1 Spare Parts List

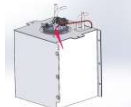
PREVIEW	ITEM NO.	PART NUMBER	DESCRIPTION	QTY Per Machine	Where Used	Where Used Image		
	1	1503021	Axial Fan, 230 V, DC, 172x150x51mm, 300-325 m³/h	1	1000050, 100051 100052, 100053			
	2	1503022	Axial Fan, 115 V, DC, 172x150x51mm, 300-325 m³/h (US ONLY)	1	1001050US, 1001051US 1001052US, 1001053US			
 Note: Metal Tube End (Screw To Tighten)	3	1400841	JG Superseal to Speedfit Elbow 5/16" Pushfit x 5/16" Pushfit	2	1000050, 100051 100052, 100053, 1001050US, 1001051US. 1001052US, 1001053US			
	4	1400438	3/8" Bulkhead Parker Legris 6316 60 00WP2	1	1000050, 100051 100052, 100053, 1001050US, 1001051US. 1001052US, 1001053US			
	5	1400827	Elbow Stem 3/8" to 3/8" - John Guest	1	1000050, 100051 100052, 100053, 1001050US, 1001051US, 1001052US, 1001053US			
	6	1400437	Bulkhead Connector 8mm (Legris)	1	1000050, 100051 100052, 100053, 1001050US, 1001051US, 1001052US, 1001053US			
	7	1400832	Elbow Stem 8mm (5/16") - 8mm (5/16") (John Guest)	13	1000050, 100051 100052, 100053, 1001050US, 1001051US, 1001052US, 1001053US			
	8	1400442	Valve Non Return Double 15mm PF Water Inlet	1	1000050, 100051 100052, 100053			
	9	1400434	Stem Reducer 15mm Stem - 3/8" PF JG NC2164	2	1000050, 100051 100052, 100053			
	10	1400443	Elbow Stem 3/8" x 5/16" Pushfit JG	1	1000050, 100051 100052, 100053, 1001050US, 1001051US. 1001052US, 1001053US			
	11	1400448	Valve Non-Return, Double Back Flow Preventer NSF & ASSE (US ONLY)	1	1001050US, 1001051US. 1001052US, 1001053US			

	12	1400449	Flare Adaptor 3/8" Pushfit x 3/8" FFL Female (JG) (US ONLY)	2	1001050US, 1001051US, 1001052US, 1001053US			
	13	1400444	Filter strainers 100 MESH 5/16" PF DMfit ADMF0505	1	1000050, 100051 100052, 100053, 1001050US, 1001051US, 1001052US, 1001053US			
	14	1400441	Equal Tee 5/16" PF JG PM0208S	4	1000050, 100051 100052, 100053, 1001050US, 1001051US, 1001052US, 1001053US			
	15	1400439	Valve Non Return 5/16" pushfit JG 5/16SCV (CO2 & Carbonated Water NRV)	1	1000050, 100052, 1001050US, 1001052US			
	16	1400436	Bulkhead Connector 1/4" (Legris)	3	1000050, 100051 100052, 100053, 1001050US, 1001051US, 1001052US, 1001053US			
	17	1501197	Harness 3 core DIN - Molex Chiller	5	1000050, 100051 100052, 100053, 1001050US, 1001051US, 1001052US, 1001053US			

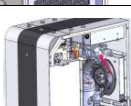
	18	1850001	Carbonator Tank 1L 100 psi 88.9mm OD	1	1000050, 100052, 1001050US, 1001052US			
	19	1502207	Valve Dispense Solenoid Dual 24V Carbonation 5/16" push fit	2	1000050, 100052, 1001050US, 1001052US			
	20	1502207_PIA1	Muller Solenoid Mount	4	1000050, 100052, 1001050US, 1001052US			
	21	1400839	5/16"-1/4" Stem-Pushfit Reducer (John Guest)	5	1000050, 100051 100052, 100053, 1001050US, 1001051US, 1001052US, 1001053US			
	22	1502209	Valve Dispense Solenoid 24V 180° (Straight Through) 5/16" JG x 5/16" JG	1	1000050, 100051 100052, 100053, 1001051US, 1001053US			
	23	1501154	Socket IEC C20	1	1000050, 100051 100052, 100053, 1001050US, 1001051US, 1001052US, 1001053US			

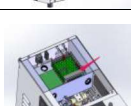
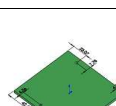
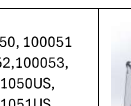
	24	1501196	DC Power Connector Jack 2.5mm Pin	2	1000050, 100051 100052, 100053, 1001050US, 1001051US, 1001052US, 1001053US			
	25	1600699	Harness FRIIA Chiller Thermostat	1	1000050, 100051 100052, 100053, 1001050US, 1001051US, 1001052US, 1001053US			
	26	1501225	LED Panel Mount White 5V M12 Steel Shroud	1	1000050, 100051 100052, 100053, 1001050US, 1001051US, 1001052US, 1001053US			
	27	1501216	SWITCH POWER ON/OFF	1	1000050, 100051 100052, 100053, 1001050US, 1001051US, 1001052US, 1001053US			
	28	1501553	Pump Lefoo 2500mL/min, 24V dc, 2.5A, (Water Booster Diaphragm Pump)	1	1000050, 100052, 1001050US, 1001052US			
	29	1601002	Power supply 24V dc, 4.5A, 100W	1	1000050, 100051 100052, 100053, 1001050US, 1001051US, 1001052US, 1001053US			
	30	1600503	P.C.B Chiller/Carbonator Control	1	1000050, 100051 100052, 100053, 1001050US, 1001051US, 1001052US, 1001053US			
	31	1600455	Triac ST-BTA25	1	1000050, 100051 100052, 100053, 1001050US, 1001051US, 1001052US, 1001053US	