



Sandwich Grill

Owner's Manual

Models

PGC28I, PSC28I

This manual includes material related to installation, use, cleaning, and care. Exploded view[s], as well as any available parts list[s] pertaining to the unit covered by this manual are also included.

This manual must be read and understood by all persons using or installing this appliance. Contact your Star dealer if you have any questions concerning installation, use, or maintenance of this equipment.

DO NOT DISCARD THIS MANUAL.



PSC28I

LIMITED EQUIPMENT WARRANTY

Star Manufacturing [as well as its subsidiaries] warrants to the original purchaser of new Star products to be free from defects in material or workmanship, under normal and proper use and maintenance service as specified by Star and upon proper installation and start-up in accordance with the instructions supplied with each Star unit. Star’s obligation under this warranty is limited to a period of one [1] year beginning from the date of original installation. The warranty period begins upon the date of original installation or up to six [6] months after the original shipment, from the factory, of the covered product. Defects that occur as a result of normal use, within the time period and limitations defined in this warranty, will at Star’s discretion have the parts replaced or repaired by Star or a Star-authorized service agency.

THIS WARRANTY IS SUBJECT TO ALL LISTED CONDITIONS

Repairs performed under this warranty are to be performed by a Star authorized service agency. Star will not be responsible for charges incurred or service performed by non-authorized repair agencies. In all cases, the nearest Star-authorized service agency must be used. Star will be responsible for normal labor charges incurred in the repair or replacement of a warranted product within 50 miles (80.5 km) of an authorized service agency. Time and expense charges for anything beyond that distance will be the responsibility of the owner. All labor will need to be performed during regular service hours. Any overtime premium will be charged to the owner. For all shipments outside the U.S.A. and Canada, please see the International Warranty for specific details. It is the responsibility of the owner to inspect and report any shipping damage claims, hidden or otherwise, promptly following delivery. No mileage or travel charges will be honored on any equipment that is deemed portable. In general, equipment with a cord and plug weighing less than 50 lb. (22.7 kg) is considered portable and should be taken or shipped to the closest authorized service agency, transportation prepaid.

PORTABLE EQUIPMENT EXAMPLES

- QCS1, QCS2, and RCS2 toasters
- Condiment dispensers

CONTACT

Should you require any assistance regarding the operation or maintenance of any Star Manufacturing; phone, email or fax our service department. In all correspondence provide the model number and serial number of the unit needing service; include the voltage or gas type.

Normal Business Hours: 8:00 a.m. to 5:00 p.m. Central

Telephone: 800-264-7827 Tech Service Option 2

Email: TechService@partstown.com

www.Star-Mfg.com

WARRANTY EXCLUSIONS

THE FOLLOWING WILL NOT BE COVERED UNDER WARRANTY.

Star’s sole obligation under this warranty is limited to either repair or replacement parts, subject to the additional limitations detailed below. This warranty neither assumes nor authorizes any person to assume obligations other than those expressly covered by this warranty.

- Any product which has not been used, maintained, or installed in accordance with the directions published in the appropriate installation sheet and/or owner’s manual, including incorrect gas or electrical connection. Star is not liable for any unit which has been mishandled, abused, misapplied, subjected to harsh chemicals, modified by unauthorized personnel, damaged by flood, fire, or other acts of nature [or God], or which have an altered or missing serial number.
- Installation, labor, and job checkouts, calibration of heat controls, air and gas burner/bypass/pilot adjustments, gas or electrical system checks, voltage and phase conversions, cleaning of equipment, or seasoning of griddle surface.
- Replacement of fuses or resetting of circuit breakers, safety controls, or reset buttons.
- Replacement of broken or damaged glass components, quartz heating elements, and light bulbs.
- Labor charges for all removable and consumable parts in gas charbroilers and hotplates, including but not limited to burners, grates, and radiants.
- Any labor charges incurred by delays, waiting time, or operating restrictions that hinder a service technician’s ability to perform service.
- Replacement of parts that fail or are damaged due to normal wear or labor for replacement of parts that can be replaced during a daily cleaning routine, such as but not limited to silicone belts, PTFE non-stick sheets, control labels, knobs, bulbs, fuses, quartz heating elements, baskets, racks, and grease drawers.
- Any economic loss of business or profits.
- Non-OEM parts. Use of non-OEM parts without Star’s approval will void the warranty.
- Units exceeding one [1] year from original installation date.

ADDITIONAL WARRANTIES

- Specific/chain-specific equipment may have additional and/or extended warranties.

PRODUCTS	PARTS	LABOR
Star Ultra Max ® fryers, griddles, charbroilers and hotplates	2 years	2 years
Star Max ® fryers, griddles, charbroilers and hotplates	2 years	2 years
Staltek™ roller grill coatings	5 years	
Cast iron grates, burners and burner shields	1 year	
Original Star, Toastmaster or Holman parts sold to repair equipment	90 days	

The foregoing warranty is in lieu of any, and all other warranties expressed or implied and constitutes the entire warranty.

TABLE OF CONTENTS

Warranty	i
General Information and Installation	1-2
Daily Operation	3
Cleaning	3
Settings	4
Exploded Views	5-8
Parts List	9-10
Wiring Diagrams	11-13
Notes	14

SAFETY SYMBOLS

These symbols are intended to alert the user to the presence of important operating and maintenance instructions in the manual accompanying the appliance.

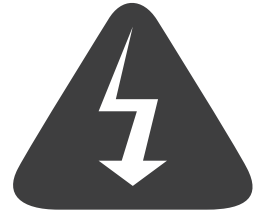

THOROUGHLY INSPECT YOUR UNIT ON ARRIVAL

This unit has been tested for proper operation before leaving our plant to ensure delivery of your unit in perfect condition. However, there are instances in which the unit may be damaged in transit. In the event you discover any type of damage to your product upon receipt, you must immediately contact the transportation company who delivered the item to you and initiate your claim with that company. If this procedure is not followed, it may affect the warranty status of the unit. If damage or loss is not apparent until after equipment is unpacked, a request for inspection of concealed damage must be made with carrier within 15 days. Please record the model number, serial number, voltage, and purchase date in the area below at the time of receipt..

Model Number _____

Serial Number _____

Voltage _____

Purchase Date _____

MAINTENANCE AND REPAIRS

Contact your local authorized service agent for service or required maintenance. Please have the information in the above fields ready when you call to ensure a faster service.

Using any part other than genuine Star factory supplied parts relieves the manufacturer of all liability. Due to periodic changes in designs, methods, procedures, policies, and regulations, the specifications contained in this document are subject to change without notice. Star reserves the right to change product specifications and design without notice. In regards to previously purchased equipment, such revisions do not entitle the buyer to corresponding changes, improvements, additions or replacements. While Star International Holdings Inc. exercises good faith efforts to provide information that is accurate, we are not responsible for errors or omissions in information provided or conclusions reached as a result of using the specifications. By using the information provided, the user assumes all risks in connection with such use.

PLEASE REFER TO THE WARRANTY PAGE FOR SPECIFIC WARRANTY INFORMATION.

AUTHORIZED SERVICE AGENT LISTING

Reference the listing provided with the unit or for an updated listing go to the website or call customer service to find an agent.

Business hours: 8:00 a.m. to 4:30 p.m. Central Standard Time

Telephone: 314-678-6303

Fax: 314-781-2714

Email: customerservice@star-mfg.com

Website: www.star-mfg.com

Please visit www.starwebconnect.com/manuals.aspx for digital versions of any documents associated with this unit.

GENERAL SAFETY INFORMATION



This equipment is designed and sold for commercial use only, and is intended for use by personnel trained and experienced in its operation. This is not sold for consumer use in and around the home nor for use directly by the general public in food service locations.

Before using your new equipment, read and understand all the instructions and labels associated with the unit prior to putting it into operation. Make sure all people associated with its use understand the units operation and safety before they use the unit.

GENERAL INSTALLATION INFORMATION

The unit is shipped fully assembled and ready to plug into a standard outlet specified for its voltage and amp draw. If improper electrical supply can be determined through troubleshooting, contact a qualified electrician prior to using the unit. Removal or replacement of the power cord or plug will void the warranty. Should you require assistance, contact your local authorized service agent for any service or required maintenance.

Allow enough space around the grill for adequate ventilation. It is recommended that you leave at least a one [1] inch (25 mm) gap on each side of the unit when possible for optimal performance.

Before using the unit for the first time, ensure to clean the unit properly. Refer to the “CLEANING” section for specific cleaning instructions.

ELECTRICAL CONNECTION

Before making any electrical connection to this unit, check that the power supply is adequate for the voltage, amperage, and requirements stated on the rating plate. Make certain to disconnect the unit from the power source before installing or removing any parts. Be absolutely sure that the ground connection for the receptacle is properly wired. Do not connect equipment to power without proper ground connections. Improper grounding may result in personal injury or fatality.



DO NOT CUT OR REMOVE THE PLUG OR GROUNDING PRONG FROM THE PLUG.



CONNECT/PLUG UNIT INTO DEDICATED AC LINE ONLY SPECIFIED ON THE DATA PLATE OF THE UNIT.



DO NOT IMMERSE OR LET THE UNIT STAND IN WATER.



DO NOT HOSE DOWN THE UNIT OR THE TABLE/COUNTER IF THE UNIT IS ON THE TABLE/COUNTER.



KEEP AWAY FROM RUNNING WATER.

ELECTRICAL REQUIREMENTS

208-240 volts and a NEMA 6-30P or 6-50P receptacle are required depending on model.



6-30P



6-50P

DAILY OPERATION



CERTAIN SURFACES ARE EXTREMELY HOT DURING OPERATION AND CARE SHOULD BE TAKEN WHILE USING THIS UNIT.



DO NOT LEAVE THE UNIT IN OPERATION WITHOUT AN ATTENDANT.



DO NOT LEAVE THE UNIT AT HIGH TEMPERATURE WHEN NOT IN USE OR DURING IDLE PERIODS.



DO NOT USE SHARP OBJECTS TO REMOVE CARBON BUILD-UP.



BEFORE CLEANING, MAKE SURE THE UNIT IS OFF, UNPLUGGED, AND HAS COOLED DOWN.



DO NOT USE ICE ON THE COOKING SURFACE.

INITIAL START UP

- i. Level the unit by adjusting the feet.
- ii. Before using the unit for the first time, clean the grill [refer to the “CLEANING” section]. Power the unit on and set the heat to 350° F (177° C). Allow the unit to heat for approximately 45 minutes. The grill will emit a small amount of smoke as the cooking surfaces reach the set temperature. This is a normal side effect of the oil burning off the platen. This is best done in a well ventilated area.
- iii. After the initial start-up, the griddle surfaces must be seasoned. Bring the grill to 300° F (149° C) [setting “5” on thermostat controlled models].
- iv. Apply a salt-free release agent and brush the cooking surface. If using an aerosol release agent, spray into a cup and then brush onto the cooking surface.
- iv. Allow the unit to sit [still set to 300° F (149° C)] for 20 minutes, and then, being careful to avoid touching the hot surfaces directly, wipe the cooking surfaces clean using a warm, damp cloth.

DAILY SEASONING

- i. Before beginning cooking or after long breaks, it may be necessary to apply a salt-free release agent and brush the cooking surface to prevent product sticking. If using an aerosol release agent, spray into a cup and then brush onto the cooking surface.

CLEANING

- i. Turn the unit “OFF” and allow it to cool enough to be safe.
- ii. Scrape off any residue or remaining product that is stuck to the cooking surface using a non-metal scraper.
- iii. Wipe down the unit with a soft cloth and a mix of water and a mild dish detergent. Rinse out the cloth and repeat using only warm water.
- iv. Remove and empty the grease drawer and clean it using a mild detergent.
- v. Allow the unit to dry completely before using.

BASIC OPERATION

- i. Turn the unit on by moving the power switch to the “ON” position. The “HEAT ON” indicator will be lit until the unit reaches the set operating temperature. This process will take approximately 30 minutes.
- ii. Once up to temperature, place product onto the cooking surface and lower the upper platen.
- iii. On timer or electronic control equipped models only, select the desired timer setting by pressing one of the product settings [press “START/STOP” to begin countdown on timer and thermostat models]. When the time reaches zero, an alarm will sound.
- iv. When the product is done cooking, raise the upper platen to the stop position and remove the product from the grill.
- v. Scrape any excess grease or residue into the grease chute, preferably using a non-metal scraper. Pay attention as the grease drawer may need to be emptied periodically throughout daily operation.
- vi. Repeat with new product or turn the power switch to “OFF” position if the grill is not being used further at this time.

SETTING TEMPERATURE

[THERMOSTAT ONLY OR THERMOSTAT AND TIMER MODELS]

Turn the thermostat dial to the desired setting to set the temperature. The elements come on when setting “1” on the dial is reached, setting “2” is at 175° F (79° C), setting “3” is at 200° F (93° C), and following that each setting adds 50° F (28° C) for each position up to setting “10” which is set at 550° F (288° C).

SETTING TIMER

[TIMER MODELS ONLY]

On timer-equipped models only, the selected preset can be changed by holding either the “1/+” button and pressing the “START/STOP” button to increase time or by holding either the “2/-” button and pressing the “START/STOP” button to decrease time. Releasing the button that is being held will save the change.

SETTING TIME AND TEMPERATURE

[ELECTRONIC CONTROL MODELS]

ON THIS MODEL, EACH HALF OF THE GRILL WILL HAVE ITS OWN INDEPENDENT CONTROLS.

- i. Press and hold “TEMP” [actual temperature displays].
- ii. While holding “TEMP” press and hold any program button on the for one second. The LED above the program number will light and the display will read “_ _ _ _”. Enter the four-digit security code sequence 4, 3, 2, 1. Once the sequence has been successfully entered, the preset time will be displayed and the LED for that program will begin to flash.
- iii. Set the desired time with the “3/+” to increase time or “4/-” to decrease time. Press the “TEMP” button to save changes.
- iv. The lower temperature setting will now be displayed and can be programmed. Set the desired temperature with the “3/+” to increase the temperature or “4/-” to decrease temperature. Press the “TEMP” button again to save changes.
- v. The upper temperature setting will now be displayed and can be programmed. Set the desired temperature with the “3/+” to increase the temperature or “4/-” to decrease temperature. Press the “TEMP” button again to save changes.
- vi. Press any other program button within 15 seconds to continue programming without re-entering the security code.

EXPLODED VIEW
LOWER PLATEN/ELEMENTS

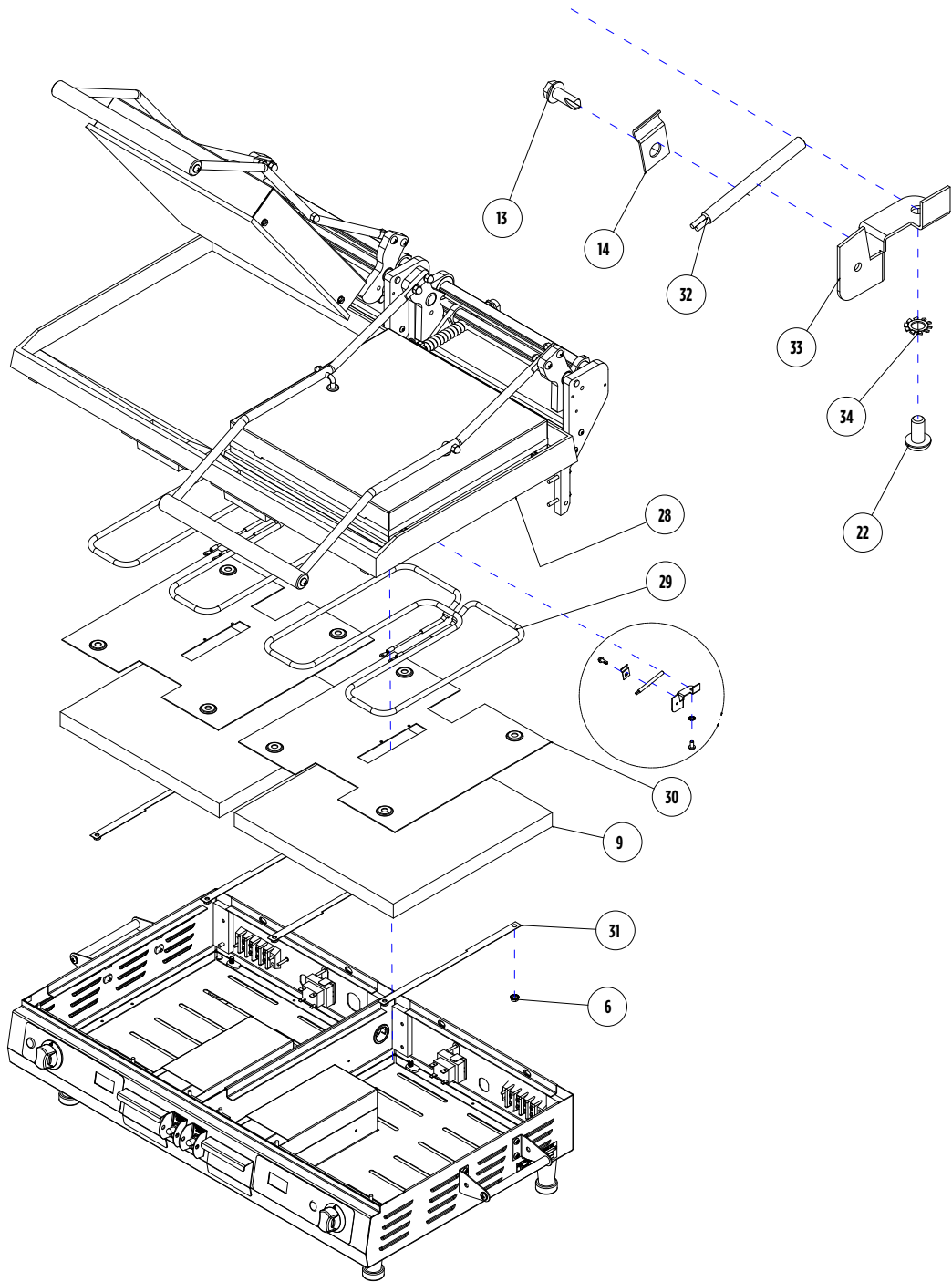

EXPLODED VIEW
UPPER PLATEN/ELEMENTS

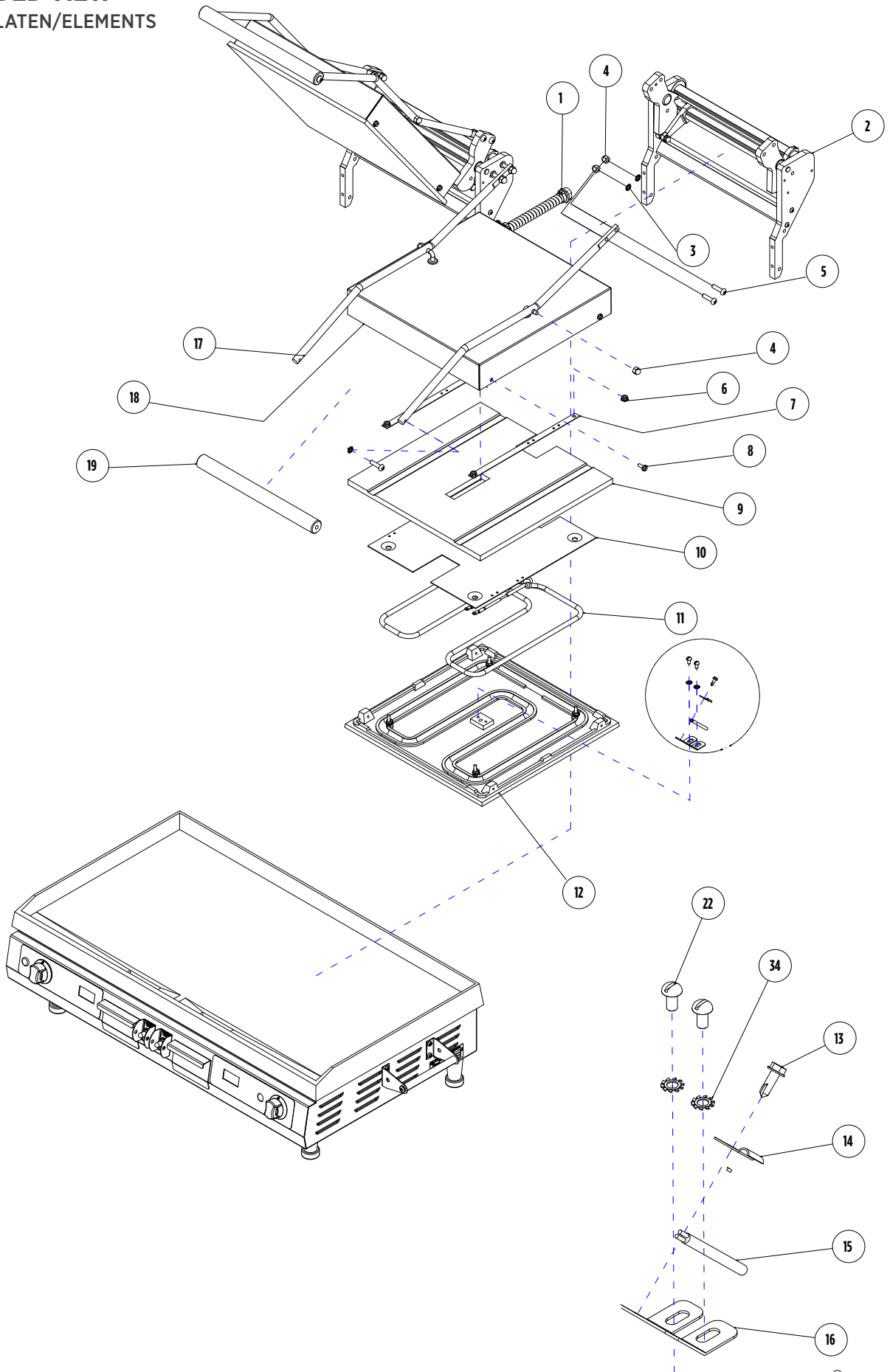

EXPLODED VIEW

LOWER BODY WITH THERMOSTAT
OR THERMOSTAT AND TIMER CONROLS

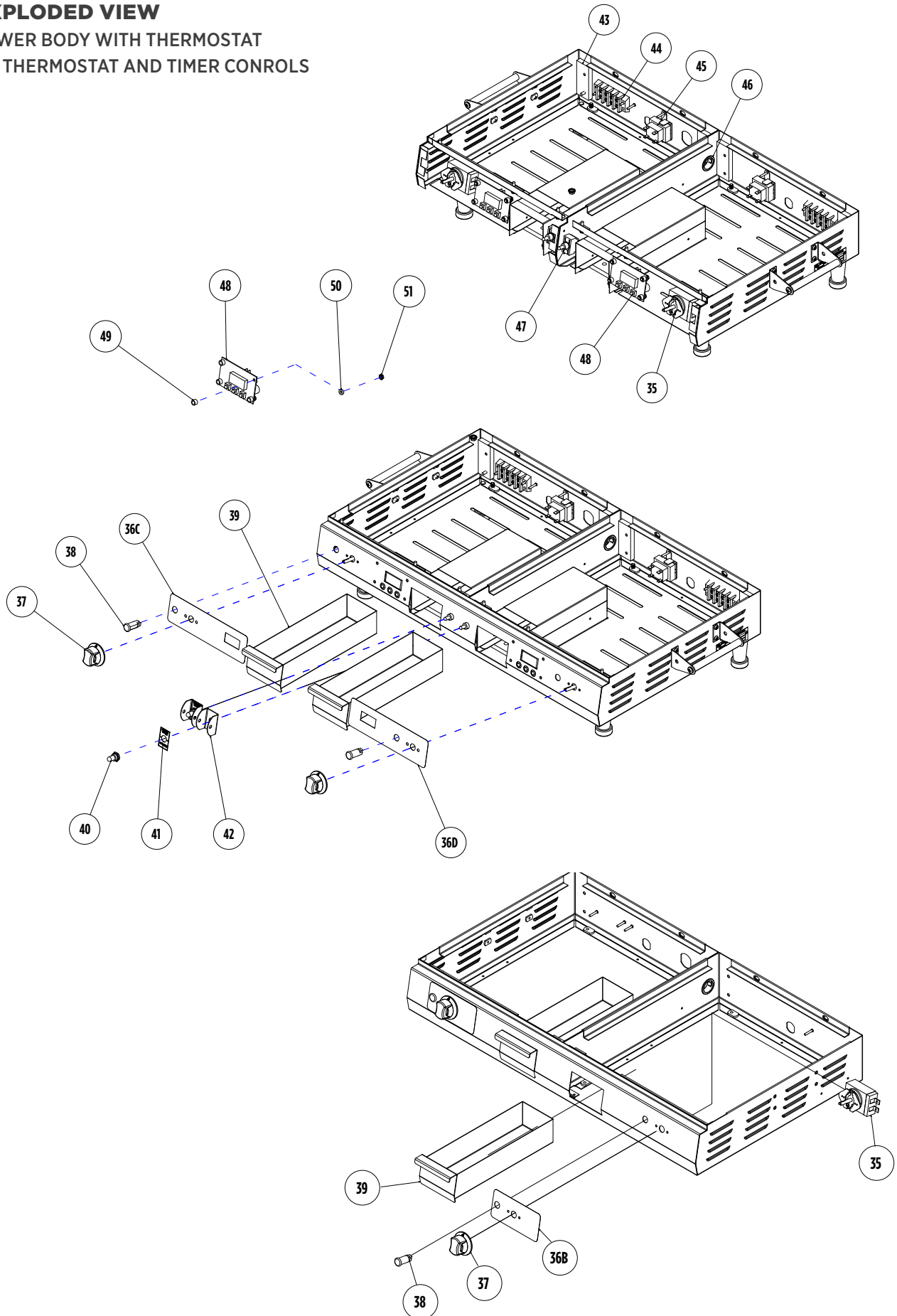

EXPLODED VIEW
BOTTOM PANELS AND LOWER BODY
WITH ELECTRONIC CONROLS

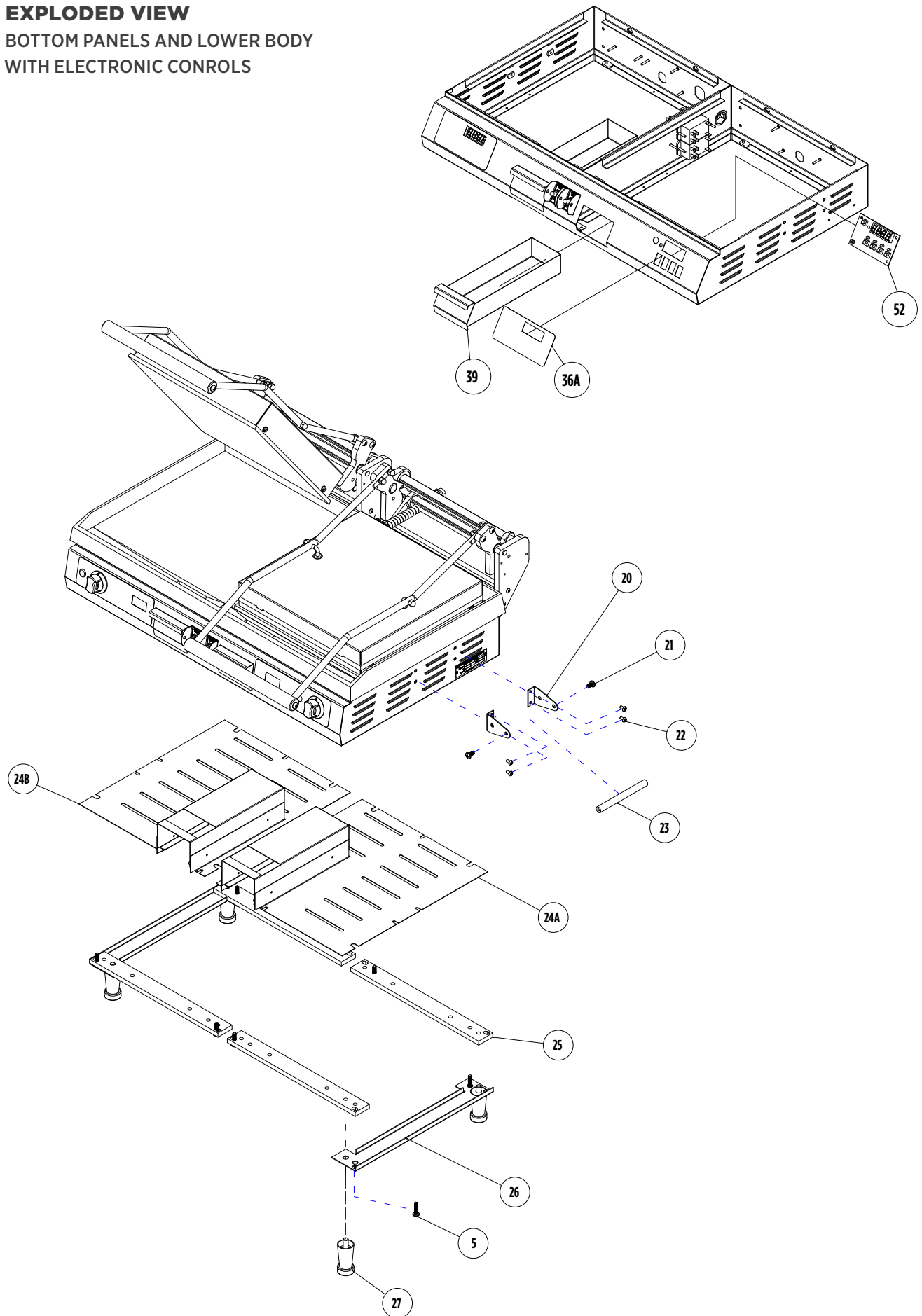

PARTS LIST

REF NO	PART NUMBER	MODEL	DESCRIPTION	QTY	PAGE NO
1	2E-Z2898	ALL	wire conduit	2	7
2	2R-Z2896	ALL	counterbalance hinge mechanism	2	7
3	2C-08-07-0262	ALL	0.25-inch lock washer	12	7
4	2C-40637	ALL	1/4-20 acorn nut	12	7
5	2C-Z2992	ALL	1/4-20 bolt	20	7, 9
6	2C-Z2893	ALL	#10-24 hex nut	24	7
7	D9-Z13099	ALL	insulation bracket	4	7
8	2C-Z5883	ALL	#10-24 screw	18	7
9	D9-Z2888	ALL	insulation	4	6, 7
10	D9-Z2075	ALL	upper element insulation plate	2	7
11	2N-Z2391	ALL	upper heating element	2	7
12	PS-GR0353	PGC models [and GT versions of PSC models]	grooved upper platen [sold as replacement kit]	2	7
	PS-GR0352	PSC models [except GT versions]	smooth upper platen [sold as replacement kit]		
13	2C-8833	ALL	#8-18 screw	2	6, 7
14	2C-Z3350	ALL	clamp	4	6, 7
15	2E-Z3278	ALL	upper RTD probe	2	7
16	D9-Z14856	ALL	probe mount bracket	2	7
17	2B-Z2987	ALL	arm	4	7
18	D9-Z4849	ALL	top housing	2	7
19	2V-Z2989	ALL	handle	2	7
20	D9-Z3071	ALL	side handle bracket	4	9
21	2C-1522	ALL	1/4-20 screw	4	9
22	2C-1512	ALL	#10-24 screw	12	6, 7, 9
23	2V-Z3072	ALL	side handle	2	9
24A	D9-GR0786	ALL	right base plate	1	9
24B	D9-GR0787	ALL	left base plate	1	9
25	2V-Z3027	ALL	lower cross support	4	9
26	D9-Z17202	ALL	lower side support	2	9
27	2A-Z12946	ALL	leg	4	9
28	PS-GR0366	PGC models	grooved lower platen [sold as replacement kit]	1	6
	PS-GR0365	PSC models	smooth lower platen [sold as replacement kit]		
29	2N-Z2392	ALL	lower heating element	1	6
30	D9-Z13338	ALL	lower element insulation plate	2	6
31	D9-Z12885	ALL	lower insulation bracket	4	6
32	2E-Z1470	ALL	lower RTD probe	2	6
33	D9-Z12027	ALL	lower probe bracket	2	6
34	2C-1827	ALL	#10 lock washer	4	6, 7
35	2T-6447	thermostat or timer and thermostat models	thermostat	2	8

PARTS LIST

REF NO	PART NUMBER	MODEL	DESCRIPTION	QTY	PAGE NO
36A	2M-Z22062	PGC28IE, PSC28IE. PSC28IEGT	electronic control label	2	9
36B	2M-Z22063	PGC28I, PSC28I. PSC28IGT	thermostat only control label	2	8
36C	2M-Z22061	PGC28IT, PSC28IT. PSC28ITGT	left timer and thermostat control label	1	8
36D	2M-Z22060	PGC28IT, PSC28IT. PSC28ITGT	right timer and thermostat control label	1	8
37	D9-GR0709	thermostat or timer and thermostat models	knob	2	8
38	2J-Z2329	thermostat or timer and thermostat models	pliot light	2	8
39	D9-Z21965	ALL	grease tray	2	8, 9
40	Z1-05-07-0013	ALL	switch boot	2	8
41	2M-Z18461	ALL	power on/off label	2	8
42	Z1-70-07-0343	ALL	switch guard	2	8
43	2A-Z21972	ALL	counterbalance hinge mount plate	4	8
44	2E-Z2894	ALL	terminal block	2	8
45	2E-05-07-0350	ALL	transformer	2	8
46	2K-Z6183	ALL	1.125-inch bushing	1	8
47	2E-Z6863	ALL	power on/off switch	2	8
48	2J-Z1836	timer models	timer	2	8
49	2K-Z1971	timer and electronic control models	spacer	8	8
50	2K-08-07-0004	timer and electronic control models	spacer	8	8
51	2C-Z2594	timer and electronic control models	#6-32 lock nut	17	8
52	2J-Z11593	electronic control models	electronic control	2	9



WIRING DIAGRAM
 PGC281/PSC281
 [ASSEMBLY VIEW, FROM BOTTOM]
 ZM-Z22161

WIRE PATTERNS AND COLORS FOR
 DISPLAY ONLY; NOT INDICATIVE OF
 WIRE COLOR/PATTERN.

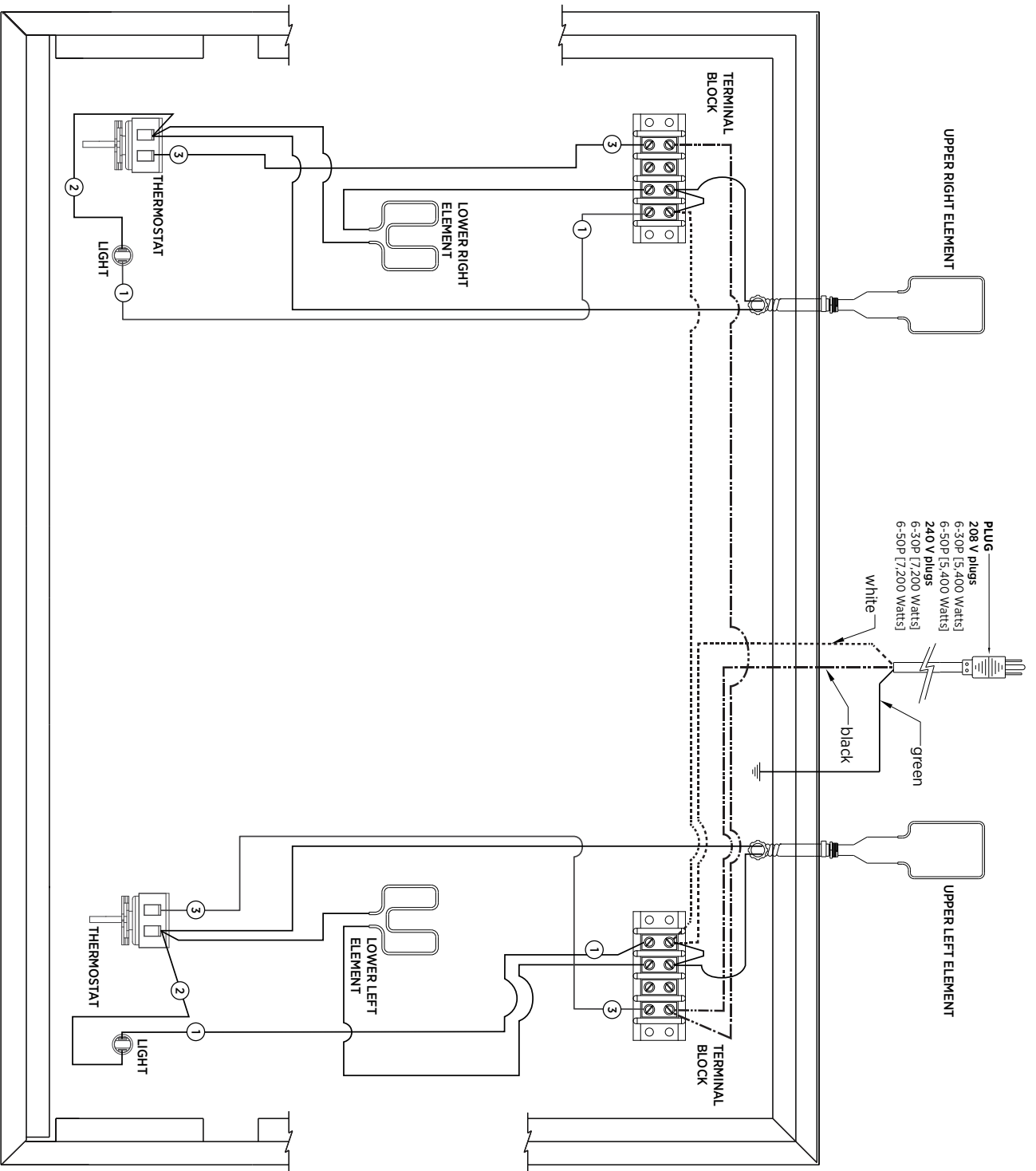



WIRE PATTERNS AND COLORS FOR DISPLAY ONLY, NOT INDICATIVE OF WIRE COLOR/PATTERN.

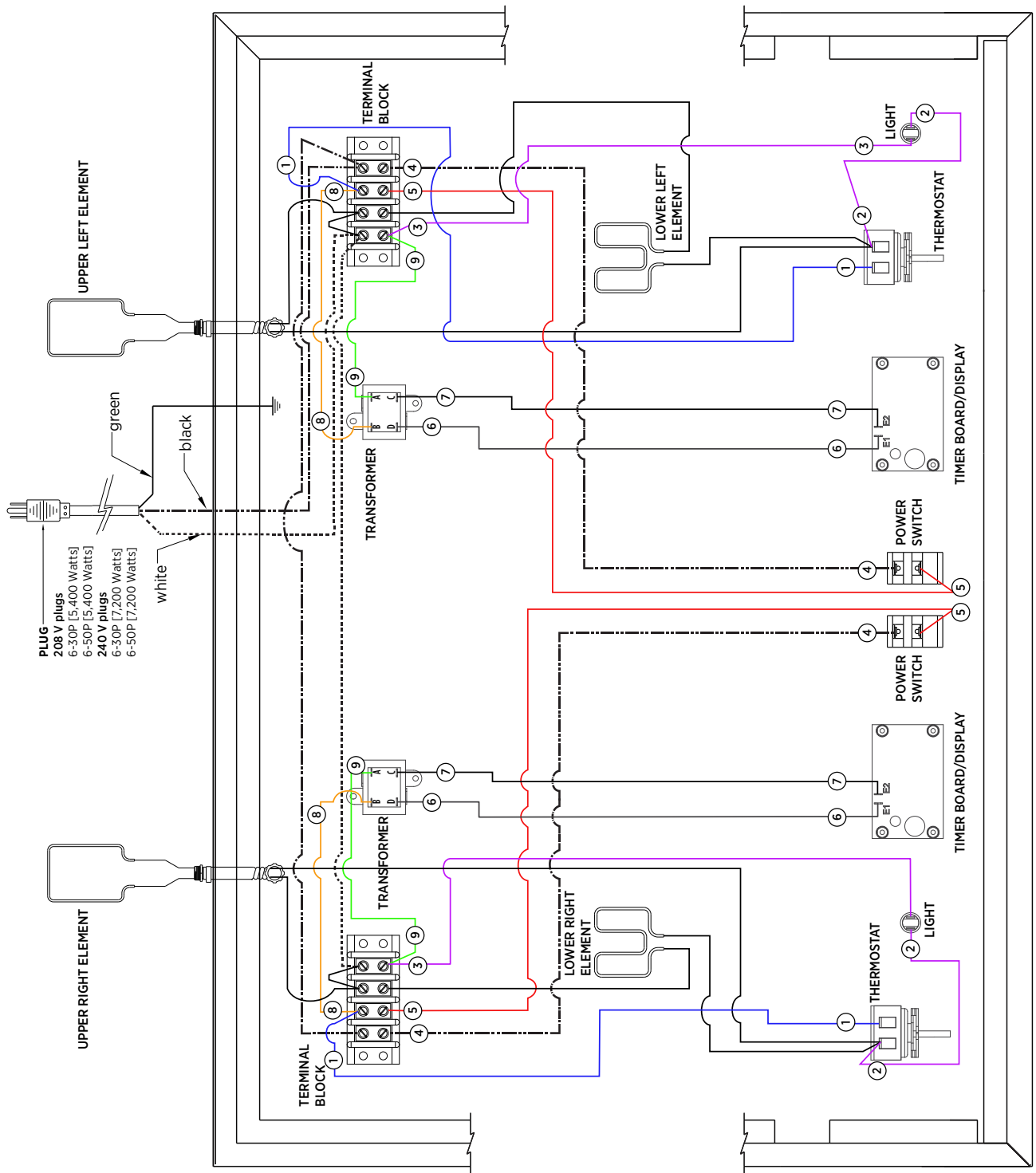



WIRING DIAGRAM
PGC281E/PGC281E [ASSEMBLY VIEW]
2M-Z22163

WIRE PATTERNS AND COLORS FOR
DISPLAY ONLY, NOT INDICATIVE OF
WIRE COLOR/PATTERN.

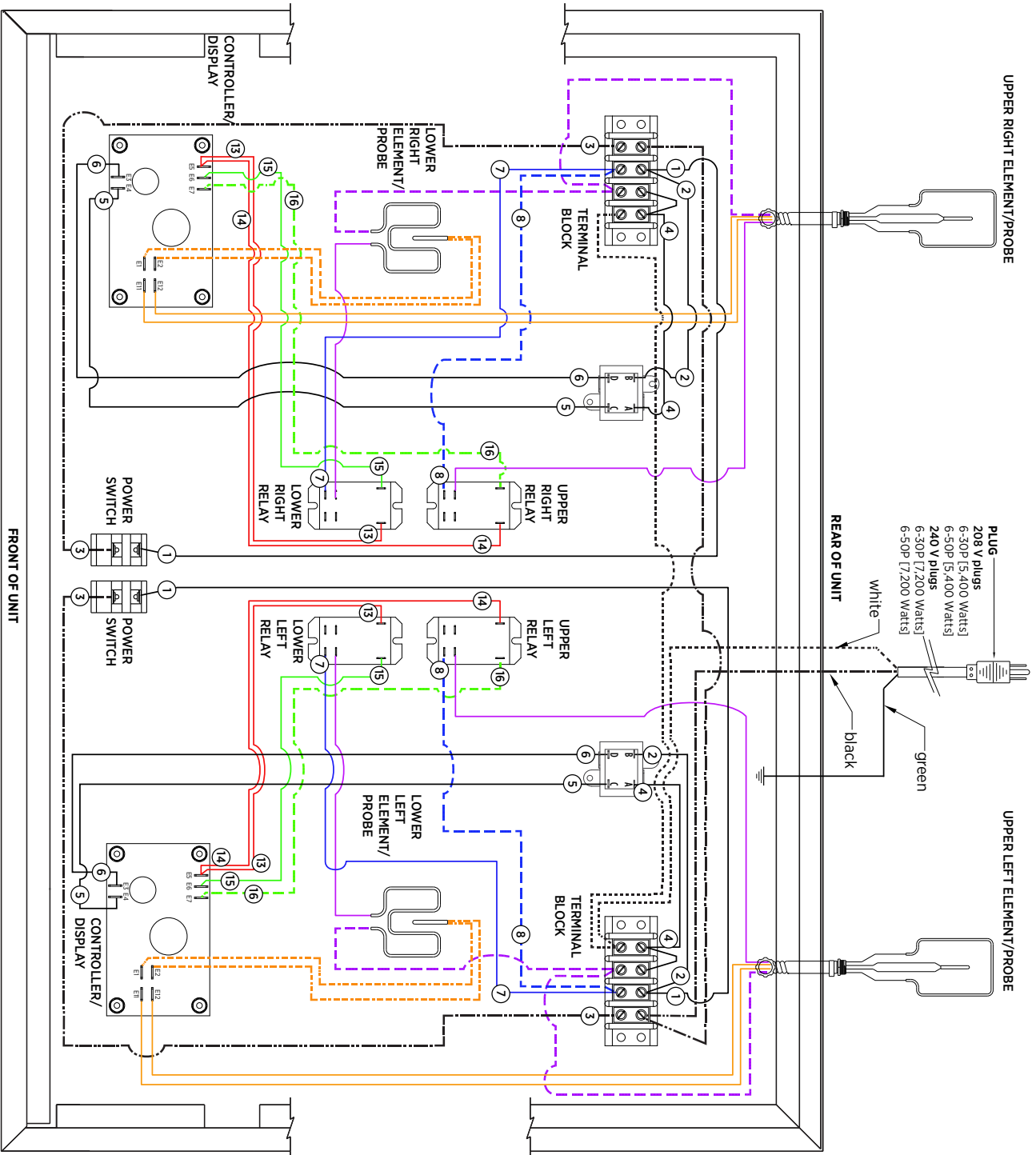

STAR MANUFACTURING INTERNATIONAL INC.

265 Hobson St • Smithville, TN 37166

Telephone 800 264 7827 • www.star-mfg.com

Printed in the U.S.A. • 2M-Z22033 REV B (02-23)

Specifications are subject to change without notice.