

# STAR<sup>®</sup> BROIL-O-DOG

MODEL  
174CBA, 174SBA  
175CBA, 175SBA

## Installation and Operation Instructions

2M-Z3755 Rev. L 10/01/2015



175CBA

**UL** US  
LISTED  
(120V Only)



## SAFETY SYMBOL



These symbols are intended to alert the user to the presence of important operating and maintenance instructions in the manual accompanying the appliance.

---

## RETAIN THIS MANUAL FOR FUTURE REFERENCE NOTICE

Using any part other than genuine Star factory supplied parts relieves the manufacturer of all liability.

Star reserves the right to change specifications and product design without notice. Such revisions do not entitle the buyer to corresponding changes, improvements, additions or replacements for previously purchased equipment.

Due to periodic changes in designs, methods, procedures, policies and regulations, the specifications contained in this sheet are subject to change without notice. While Star International Holdings Inc., Company exercises good faith efforts to provide information that is accurate, we are not responsible for errors or omissions in information provided or conclusions reached as a result of using the specifications. By using the information provided, the user assumes all risks in connection with such use.

## MAINTENANCE AND REPAIRS

Contact your local authorized service agent for service or required maintenance.

Please record the model number, serial number, voltage and purchase date in the area below and have it ready when you call to ensure a faster service.

Model No. \_\_\_\_\_  
Serial No. \_\_\_\_\_  
Voltage \_\_\_\_\_  
Purchase Date \_\_\_\_\_

### Authorized Service Agent Listing

Reference the listing provided with the unit

or

for an updated listing go to:

**Website:** [www.star-mfg.com](http://www.star-mfg.com)  
**E-mail** [customerservice@star-mfg.com](mailto:customerservice@star-mfg.com)

### Service Help Desk

**Business Hours:** 8:00 am to 4:30 p.m. Central Standard Time

**Telephone:** (314) 678-6303

**Fax:** (314) 781-2714

**E-mail** [customerservice@star-mfg.com](mailto:customerservice@star-mfg.com)

**Website:** [www.star-mfg.com](http://www.star-mfg.com)

**Mailing Address:** Star International Holdings Inc., Company  
10 Sunnen Drive  
St. Louis, MO 63143  
U.S.A

## SPECIFICATIONS

---

### 174SBA

Type: Spike Wheel  
Capacity: 24 Hot Dogs, 12 Buns  
Electrical: 120 volt, 60 hertz, single phase, 1150 watts, 9.58 amps  
230 volt, 60 hertz, single phase, 1060 watts, 4.61 amps  
Cord Length - 4 ft.  
Plug: 120V NEMA Spec - NEMA 5-15P  
230V CEE-7/VII rated 16A 250V  
Dimensions: 13 1/2"W x 14 1/2"D x 24"H  
(34.29 cm W x 36.83 cm D x 60.96 cm H)

---

### 174CBA

Type: Cradle Wheel  
Capacity: 18 Hot Dogs, 12 Buns  
Electrical: 120 volt, 60 hertz, single phase, 1150 watts, 9.58 amps  
230 volt, 60 hertz, single phase, 1060 watts, 4.61 amps  
Cord Length - 4 ft.  
Plug: 120V NEMA Spec - NEMA 5-15P  
230V CEE-7/VII rated 16A 250V  
Dimensions: 13 1/2"W x 14 1/2"D x 24"H  
(34.29 cm W x 36.83 cm D x 60.96 cm H)

---

### 175SBA

Type: Spike Wheel  
Capacity: 48 Hot Dogs, 32 Buns  
Electrical: 120 volt, 60 hertz, single phase, 1350 watts, 11.25 amps  
230V volt, 60 hertz, single phase, 1240 watts, 5.39 amps  
Cord Length - 4 ft.  
Plug: 120V NEMA Spec - NEMA 5-15P  
230V CEE-7/VII rated 16A 250V  
Dimensions: 19 1/2"W x 14 1/2"D x 24"H  
(49.53 cm W x 36.83 cm D x 60.96 cm H)

---

### 175CBA

Type: Cradle Wheel  
Capacity: 36 Hot Dogs, 32 Buns  
Electrical: 120 volt, 60 hertz, single phase, 1350 watts, 11.25 amps  
230V volt, 60 hertz, single phase, 1240 watts, 5.39 amps  
Cord Length - 4 ft.  
Plug: 120VNEMA Spec - NEMA 5-15P  
230V CEE-7/VII rated 16A 250V  
Dimensions: 19 1/2"W x 14 1/2"D x 24"H  
(49.53 cm W x 36.83 cm D x 60.96 cm H)

---



## CAUTION

This equipment is designed and sold for commercial use only by personnel trained and experienced in its operation and is not sold for consumer use in and around the home nor for use directly by the general public in food service locations.

Before using your new equipment, read and understand all the instructions & labels associated with the unit prior to putting it into operation. Make sure all people associated with its use understand the units operation & safety before they use the unit.

All shipping containers should be checked for freight damage both visible and concealed. This unit has been tested and carefully packaged to insure delivery of your unit in perfect condition. If equipment is received in damaged condition, either apparent or concealed, a claim must be made with the delivering carrier.

Concealed damage or loss - if damage or loss is not apparent until after equipment is unpacked, a request for inspection of concealed damage must be made with carrier within 15 days. Be certain to retain all contents plus external and internal packaging materials for inspection. The carrier will make an inspection and will supply necessary claim forms.

This equipment is designed and sold for commercial use only by personnel trained and experienced in its operation and is not sold for consumer use in and around the home nor for use directly by the general public in food service locations.

## INSTALLATION

1. Clean unit inside and outside before placing in service. (See Cleaning)
2. Install the low E Tempered, oxide coated glass (**reflective side facing inward**) as shown below. The 1/4" thick glass goes in the side location, resting in the track formed into the shelf. The 1/8" thick glass goes on the front of the unit.

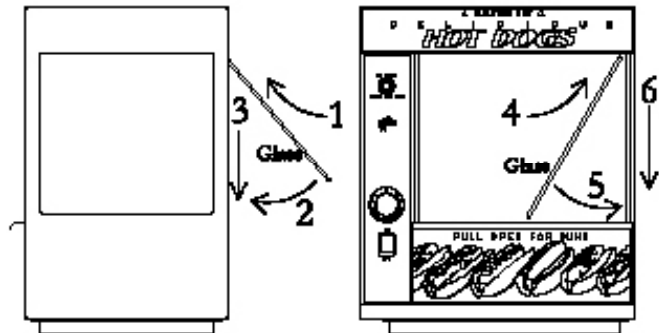

3. Install the wire shaft support as shown in steps 7 and 8. Mounting holes have been punched in the ceiling of the unit.

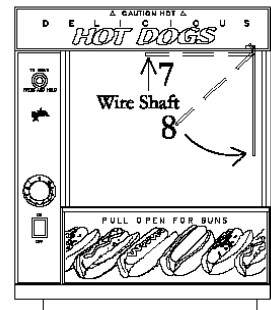

4. Install the hot dog wheel as shown in steps 9 and 10. While holding the wire shaft support against the side glass, install the hot dog wheel in the broiler by placing the slotted end of the shaft into the motor coupling at the left of the broiler (step 9). Turn the shaft until the slot engages with the coupling pin. Raise the grooved end of the shaft up and into the wire shaft support on the right side of the broiler (step 10).

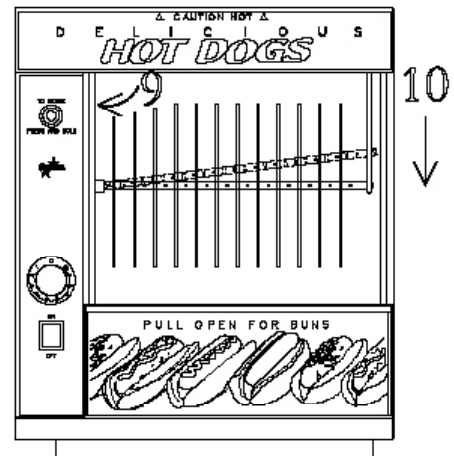

5. Place the unit in a prominent location on a level counter, where the revolving hot dogs will attract attention.
6. Precaution should be taken so customers do not come in contact with the hot unit.
7. Plug the power cord into a suitable 120 volt outlet that can provide the required wattage. Having other appliances on a circuit, may prevent your unit from receiving the necessary voltage.

## GENERAL OPERATING PROCEDURES

1. Pre-heat unit for 15 minutes while set at 10.
2. Place the desired quantity of hot dogs on the holders. NOTE: A lower temp control setting may be used for slower broiling. The time required to broil the hot dogs will vary, depending upon the size and the temperature of the hot dogs when placed in the Broil-O-Dog.
3. Place the desired quantity of buns in the bun drawer. For best results leave buns in the bag. A 50 watt warming elements is installed to keep buns warm.
4. Turn control to 6 or 7 to keep the hot dogs in a ready-to-serve condition. Hot dogs can be held for several hours on this unit without loss of flavor or shriveling.
5. Load or unload the hot dog wheel by pressing in and holding the serve switch to stop the hot dog wheel.

**NOTE: When you turn the switch to the "OFF" position, you turn off the heating element.**

## COOKING

The heat control provides an infinite range of settings for a wide variety of hot dogs and installation conditions. The size, content and shape of the product and the installation of any sanitary food shields or sneeze guards will determine the proper heat setting. The National Sanitation Foundation requires that perishable foods be kept at 140°F or above during serving periods. The product should be kept refrigerated until ready for use. Cooking time will vary depending on the starting temperature and the qualities of the product.

The heat control provides an infinite range of settings for a wide variety of hot dogs and installation conditions. The size, content and shape of the product and the installation of any sanitary food shields or sneeze guards will determine the proper heat setting. The National Sanitation Foundation requires that perishable foods be kept at 140°F or above during serving periods. The product should be kept refrigerated until ready for use. Cooking time will vary depending on the starting temperature and the qualities of the product.

## CLEANING

1. Place ON/OFF switch in "OFF" position.
2. Remove the hot dog wheel and drip tray.
3. Remove the wheel hanger at right side of broiler.
4. The glass is removable for cleaning but care must be taken when doing so.
5. Clean all of the above parts and inside and outside of the unit with mild soap and water; rinse and install parts.
6. These models require the removal of the bun drawer to remove the bun pan. To remove the bun drawer, grab the drawer by both sides and pull it out all the way. Lift the front to unhook the drawer slide from rear drawer roller. Pull the drawer the remainder of the way out. Use caution not to drop the drawer when reaching the end of the drawer slide travel. To reinsert the drawer, first hook the drawer slide over the front roller then the back roller (See Figure1-Figure 3).



**TO AVOID COMBUSTION, REPLACEMENT GLASS MUST BE LOW TEMPERED, TIN OXIDE COATED. CALL STAR SERVICE HELP DESK.**

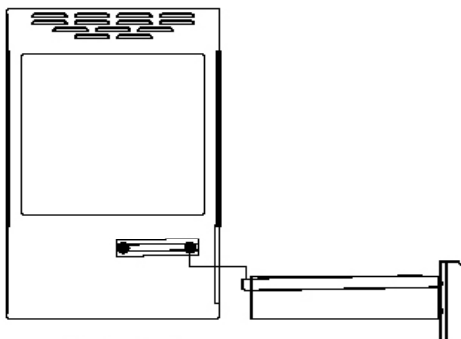

FIGURE 1

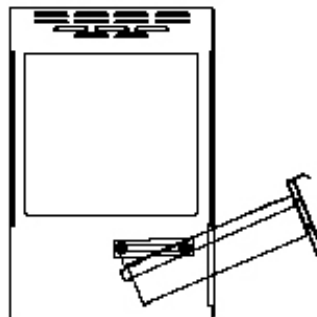

FIGURE 2

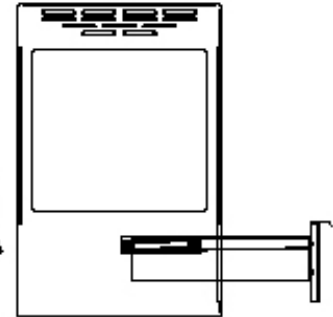

FIGURE 3

## **MAINTENANCE PROCEDURES**

### **LIGHT BULB**

Use a 15 watt, 120 volt (or 240V if applicable) appliance size oven-type lamp.

### **GLASS REPLACEMENT**

Refer to the installation procedures located on page 4. To prevent surrounding areas from getting to hot, use only a low E Tempered, oxide coated glass (reflective side facing inward) when replacing glass. This glass can be purchased by contacting Star (contact information located on the inside front cover).

### THOROUGHLY INSPECT YOUR UNIT ON ARRIVAL

This unit has been tested for proper operation before leaving our plant to insure delivery of your unit in perfect condition. However, there are instances in which the unit may be damaged in transit. In the event you discover any type of damage to your product upon receipt, you must immediately contact the transportation company who delivered the item to you and initiate your claim with same. If this procedure is not followed, it may affect the warranty status of the unit.

### LIMITED EQUIPMENT WARRANTY

All workmanship and material in Star products have a one (1) year limited warranty on parts & labor in the United States and Canada. Such warranty is limited to the original purchaser only and shall be effective from the date the equipment is placed in service. Star's obligation under this warranty is limited to the repair of defects without charge, by the factory authorized service agency or one of its sub-agencies. Models that are considered portable (*see below*) should be taken to the closest Star service agency, transportation prepaid.

- > Star will not assume any responsibility for loss of revenue.
- > On all shipments outside the United States and Canada, see International Warranty.
- \* The warranty period for the Ultra-Max, Hot Plates, Griddles, Charbroilers is (3) years parts & labor.
- \* The warranty period for the Star-Max, Charbroilers, Griddles, Hot Plates, Fryers & Finishing Oven is (2) years parts & labor.
- \* The warranty period for the JetStar six (6) ounce & Super JetStar eight (8) ounce series popcorn machines is two (2) years.
- \* The warranty period for the Chrome-Max Griddles is five (5) years on the griddle surface. See detailed warranty provided with unit.
- \* The warranty period for Dura-Tec coatings is one year under normal use and reasonable care. This warranty does not apply if damage occurs to Dura-Tec coatings from improper cleaning, maintenance, use of metallic utensils, or abrasive cleaners, abrasive pads, product identifiers and point-of-sale attachments, or any other non-food object that comes in continuous contact with the roller coating. This warranty does not apply to the "non-stick" properties of such materials.
- > This warranty does not apply to "Special Products" but to regular catalog items only. Star's warranty on "Special Products" is six (6) months on parts and ninety (90) days on labor.
- > This warranty does not apply to any item that is disassembled or tampered with for any purpose other than repair by a Star Authorized Service Center or the Service Center's sub-agency.
- > This warranty does not apply if damage occurs from improper installation, misuse, wrong voltage, wrong gas or operated contrary to the Installation and Operating instructions.
- > This warranty is not valid on Conveyor Ovens *unless* a "start-up/check-out" has been performed by a Factory Authorized Technician.

### PARTS WARRANTY

Parts that are sold to repair out of warranty equipment are warranted for ninety (90) days. The part only is warranted, the labor to replace the part is **NOT** warranted.

### SERVICES NOT COVERED BY WARRANTY

1. Travel time and mileage rendered beyond the 50 mile radius limit
2. Mileage and travel time on portable equipment (*see below*)
3. Labor to replace such items that can be replaced easily during a daily cleaning routine, ie; removable kettles on fryers, knobs, grease drawers on griddles, etc.
4. Installation of equipment
5. Damages due to improper installation
6. Damages from abuse or misuse
7. Operated contrary to the Operating and Installation Instructions
8. Cleaning of equipment
9. Seasoning of griddle plates
10. Voltage conversions
11. Gas conversions
12. Pilot light adjustment
13. Miscellaneous adjustments
14. Thermostat calibration and by-pass adjustment
15. Resetting of circuit breakers or safety controls or reset buttons
16. Replacement of bulbs
17. Replacement of fuses
18. Repair of damage created during transit, delivery, & installation OR created by acts of God

### PORTABLE EQUIPMENT

Star will not honor service bills that include travel time and mileage charges for servicing any products considered "Portable" including items listed below. These products should be taken to the Service Agency for repair:

- \* The Model 510FD, 510FF Fryer.
- \* The Model 526TOA Toaster Oven.
- \* The Model J4R, 4 oz. Popcorn Machine.
- \* The Model 518CMA & 526CMA Cheese Melter.
- \* The Model 12MC & 15MC & 18MCP Hot Food Merchandisers.
- \* The Model 12NCPW & 15NCPW Nacho Chip/Popcorn Warmer.
- \* All Hot Dog Equipment **except Roller Grills & Drawer Bun Warmers.**
- \* All Nacho Cheese Warmers **except Model 11WLA Series Nacho Cheese Warmer.**
- \* All Condiment Dispensers **except the Model HPD & SPD Series Dispenser.**
- \* All Specialty Food Warmers **except Model 130R, 11RW Series, and 11WSA Series.**
- \* All QCS/RCS Series Toasters **except Model QCS3 & RCS3 Series.**
- \* All Fast Steamer Models **except Direct Connect Series.**

### ALL:

- \* Pop-Up Toasters
- \* Butter Dispensers
- \* Pretzel Merchandisers (Model 16PD-A Only)
- \* Pastry Display Cabinets
- \* Nacho Chip Merchandisers
- \* Accessories of any kind
- \* Sneeze Guards
- \* Pizza Ovens (Model PO12 Only)
- \* Heat Lamps
- \* Pumps-Manual

The foregoing warranty is in lieu of any and all other warranties expressed or implied and constitutes the entire warranty.

### FOR ASSISTANCE

Should you need any assistance regarding the Operation or Maintenance of any Star equipment; write, phone, fax or email our Service Department. In all correspondence mention the Model number and the Serial number of your unit, and the voltage or type of gas you are using.