

OPERATOR'S MANUAL



Model 490 Extra Firm Product Smoothie Machine

Original Operating Instructions

067929-M

2/12/10 (Original Publication)
(Updated 8/7/2020)

Section 1: To the Installer

Installer Safety	1-1
Site Preparation	1-1
Air-Cooled Machines	1-2
Water Connections	1-2
Electrical Connections	1-2
Refrigerant	1-3

Section 2: To the Operator

Section 3: Safety

Section 4: Operator Parts Identification

Model 490	4-1
Beater Door Assembly	4-2
Accessories	4-3

Section 5: User Interface

Section 6: Operating Procedures

Assembly	6-1
Sanitizing	6-4
Priming	6-6
Closing Procedures	6-6
Draining Product from the Freezing Cylinder	6-6
Rinsing	6-7
Cleaning	6-7
Disassembly	6-7
Brush Cleaning	6-7

Section 7: Operator Checklist

During Cleaning and Sanitizing	7-1
Troubleshooting Bacterial Count	7-1
Regular Maintenance Checks	7-1
Winter Storage	7-2

Table of Contents

Section 8: Troubleshooting Guide

Section 9: Parts Replacement Schedule

Section 10: Limited Warranty on Equipment

Section 11: Limited Warranty on Parts

The following information has been included in the manual as safety and regulatory guidelines. For complete installation instructions, please see the Installation Checklist.

Installer Safety



IMPORTANT! In all areas of the world, machine should be installed in accordance with existing local codes. Please contact your local authorities if you have any questions.

Care should be taken to ensure that all basic safety practices are followed during the installation and servicing activities related to the installation and service of Taylor® machines.

- Only authorized Taylor service personnel should perform installation, maintenance, and repairs on Taylor machines.
- Authorized service personnel should consult OSHA Standard 29CFR1910.147 or the applicable code of the local area for the industry standards on lockout/tagout procedures before beginning any installation or repairs.
- Authorized service personnel must ensure that the proper personal protective equipment (PPE) is available and worn when required during installation and service.
- Authorized service personnel must remove all metal jewelry, rings, and watches before working on electrical equipment.



DANGER! The main power supply(s) to the machine must be disconnected prior to performing any installation, maintenance, or repairs. **For Cord-Connected Machines:** Only authorized Taylor service technicians or licensed electricians may install a plug or replacement cord on the machine. Failure to follow this instruction may result in personal injury or death from electrical shock or hazardous moving parts, as well as poor performance or damage to the machine.

Note: All repairs must be performed by an authorized

Taylor service technician.



WARNING! This machine has many sharp edges that can cause severe injuries.

Site Preparation



WARNING! Only install this machine in a location where its use and maintenance is restricted to trained personnel. Failure to comply may result in personal injury.

Review the area the machine is to be installed in before uncrating the machine, making sure all possible hazards to the user or the equipment have been addressed.

For Indoor Use Only: This machine is designed to operate indoors, under normal ambient temperatures of 70°F to 75°F (21°C to 24°C). The freezer has successfully performed in high ambient temperatures of 104°F (40°C) at reduced capacities.



WARNING! This machine must **NOT** be installed in an area where a water jet or hose can be used. **NEVER** use a water jet or hose to rinse or clean the machine. Failure to follow this instruction may result in electrocution.



CAUTION! This machine must be installed on a level surface to avoid the hazard of tipping. Extreme care should be taken in moving this machine for any reason. Two or more persons are required to safely move this machine. Failure to comply may result in personal injury or damage to the machine.

The authorized installer should inspect the machine for damage and promptly report any damage to the local authorized Taylor distributor.

This machine is made using USA sizes of hardware. All

metric conversions are approximate and vary in size.

Air-Cooled Machines

Do not obstruct air intake and discharge openings.

1 Air-cooled machines require a minimum of 6 in. (152 mm) of clearance on both sides of the freezer. It is recommended to place the rear of the machine against the wall to prevent recirculation of warm air. Failure to allow adequate clearance can reduce the refrigeration capacity of the freezer and possibly cause permanent damage to the compressors.

Water Connections

Water-Cooled Machines Only

An adequate cold water supply must be provided with a hand shutoff valve. On the underside rear of the base pan, two 3/8 in. IPS (for single-head machines) or two 1/2 in. IPS (for double-head machines) water connections for inlet and outlet have been provided for easy hookup. Permanently connect the machine using 1/2 in. (12.7 mm) inside diameter water lines. (Flexible lines are recommended, if local codes permit.)

Depending on local water conditions, it may be advisable to install a water strainer to prevent foreign substances from clogging the automatic water valve. There will be only one water **in** and one water **out** connection for both single-head and double-head machines. **Do not** install a hand shutoff valve on the water **out** line. Water should always flow in this order: first, through the automatic water valve; second, through the condenser; and third, through the outlet fitting to an **open trap drain**.



IMPORTANT! A backflow prevention device is required on the incoming water connection side. Please see the applicable national, state, and local codes for determining the proper configuration. Water pressure to the unit must not exceed 150 psi (1034 kPa).

Electrical Connections



IMPORTANT! In the United States, this machine is intended to be installed in accordance with the National Electrical Code (NEC), ANSI/NFPA 701987. The purpose of the NEC is the practical safeguarding of persons and property from hazards arising from the use of electricity. This code contains provisions considered necessary for safety.

In all other areas of the world, the machine should be installed in accordance with the existing local codes. Please contact your local authorities if you have any questions.

Each machine requires one power supply for each data label on the machine. Check the data label(s) on the machine for branch circuit overcurrent protection or fuse, circuit ampacity, and other electrical specifications.

See the wiring diagram provided inside the electrical box for proper power connections.



FOLLOW YOUR LOCAL ELECTRICAL CODES.



WARNING! This machine must be properly grounded. Failure to do so can result in severe personal injury from electrical shock.



IMPORTANT! An equipotential grounding lug is provided with this machine. Some countries require the grounding lug be properly attached to the rear of the frame by the authorized installer. The installation location is marked by the equipotential bonding symbol (5021 of IEC 60417-1) on both the removable panel and the machine's frame.



IMPORTANT!

- Stationary machines which are not equipped

with a power cord and a plug or another device to disconnect the machines from the power source must have an all-pole disconnecting device with a contact gap of at least 0.125 in. (3 mm) installed in the external installation.

- Machines that are permanently connected to fixed wiring and for which leakage currents may exceed 10 mA, particularly when disconnected or not used for long periods, or during initial installation, shall have protective devices to protect against the leakage of current, such as a GFI, installed by the authorized personnel to the local codes.
- Supply cords used with this machine shall be oil-resistant, sheathed flexible cable not lighter than ordinary polychloroprene or other equivalent synthetic elastomer-sheathed cord (code designation 60245 IEC 57) installed with the proper cord anchorage to relieve conductors from strain, including twisting, at the terminals and protect the insulation of the conductors from abrasion.

If the supply cord is damaged, it must be replaced by an authorized Taylor service technician in order to avoid a hazard. Secure the supply cord ground lead to the machine in a location where if the cord is pulled, the main power leads will become taut before the ground lead can break loose.

Beater Rotation



NOTICE! Beater rotation must be clockwise as viewed looking into the freezing cylinder.

To correct the rotation on a three-phase machine, interchange any two incoming power supply lines at the machine main terminal block only. To correct rotation on a single-phase machine, exchange leads inside the beater motor. (Follow the diagram printed on the motor.)

Electrical connections are made directly to the terminal block provided in the main control box located behind the service panel.

It is recommended that beater rotation adjustment be performed by an authorized Taylor service technician.

Refrigerant



CAUTION! This equipment contains fluorinated greenhouse gases (F-Gas) to provide refrigeration using a hermetically sealed circuit or within foam insulation. This unit's type of gas, quantity, Global Warming Potential (GWP) and CO₂ tonnes equivalent information is recorded on the unit's data label. The refrigerant used is generally considered non-toxic and non-flammable. However any gas under pressure is potentially hazardous and must be handled with caution.

NEVER fill any refrigerant cylinder completely with liquid. Filling the cylinder to approximately 80% will allow for normal expansion.



CAUTION! Use only approved refrigerant listed on the machine's data label or authorized through a manufacturer's technical bulletin. The use of any other refrigerant may expose users and operators to unexpected safety hazards.



WARNING! Refrigerant liquid sprayed onto the skin may cause serious damage to tissue. Keep eyes and skin protected. If refrigerant burns should occur, flush the area immediately with cold water. If burns are severe, apply ice packs and contact a physician immediately.



NOTICE! Taylor reminds technicians to be aware of and in compliance with local government laws regarding refrigerant recovery, recycling, and reclaiming systems. For information regarding applicable local laws, please contact your local authorized Taylor distributor.



IMPORTANT! Refrigerants and their associated lubricants may be extremely moisture absorbent. When opening a refrigeration system, the maximum time the system is open must not exceed 15 minutes. Cap all open tubing to prevent humid air or water from being absorbed by the oil.

1

The freezer you have purchased has been carefully engineered and manufactured to give you dependable operation. The Taylor Model 490, when properly operated and cared for, will produce a consistent quality product. Like all mechanical products, it will require cleaning and maintenance. A minimum amount of care and attention is necessary if the operating procedures outlined in this manual are followed closely.



IMPORTANT! This manual should be read before operating or performing any maintenance on the machine.

Your Taylor machine will **NOT** compensate for and/or correct any errors made during the setup or filling operations. Thus, the initial assembly, setup, and priming procedures are of extreme importance. It is strongly recommended that all personnel responsible for the machine's operation, including assembly and disassembly, go through these procedures together in order to be properly trained and to make sure that all personnel understand their role in using and maintaining the machine.

In the event you should require technical assistance, please contact your local authorized Taylor distributor.

Note: Your Taylor warranty is valid only if the parts are authorized Taylor parts, purchased from the local authorized Taylor distributor, and only if all required service work is provided by an authorized Taylor service technician. Taylor reserves the right to deny warranty claims on machines or parts if Taylor-unapproved parts or incorrect refrigerant were installed in the unit, system modifications were performed beyond factory recommendations, or it is determined that the failure was caused by abuse, misuse, neglect, or failure to follow all operating instructions. For full details of your Taylor warranty, please see the Limited Warranty section in this manual.

Note: Constant research results in steady improvements; therefore, information in this manual is subject to change without notice.



IMPORTANT! If the crossed-out wheeled-bin symbol is affixed to this machine, it signifies that this machine is compliant with the EU Directives as well as other similar end-of-life legislation in effect after August 13, 2005. Therefore, it must be collected separately after its use is completed and cannot be disposed as unsorted municipal waste.

The user is responsible for delivering the machine to the appropriate collection facility, as specified by your local code.

For additional information regarding applicable local disposal laws, please contact the municipal waste facility and/or local authorized Taylor distributor.

Compressor Warranty Disclaimer

The refrigeration compressor(s) on this machine are warranted for the term stated in the Limited Warranty section in this manual. However, due to the Montreal Protocol and the U.S. Clean Air Act Amendments of 1990, many new refrigerants are being tested and developed, thus seeking their way into the service industry. Some of these new refrigerants are being advertised as drop-in replacements for numerous applications. It should be noted that in the event of ordinary service to this machine's refrigeration system, **only the refrigerant specified on the affixed data label should be used.** The unauthorized use of alternate refrigerants will void your Taylor compressor warranty. It is the machine owner's responsibility to make this fact known to any technician he employs.

It should also be noted that Taylor does not warrant the refrigerant used in its equipment. For example, if the refrigerant is lost during the course of ordinary service to this machine, Taylor has no obligation to either supply or provide replacement refrigerant either at billable or unbillable terms. Taylor will recommend a suitable replacement if the original refrigerant is banned, obsoleted, or no longer available during the five-year Taylor warranty of the compressor.

From time-to-time Taylor may test new refrigerant alternates. Should a new refrigerant alternate prove, through Taylor's testing, that it would be accepted as a drop-in replacement for this machine, then the disclaimer in this **Compressor Warranty Disclaimer** section will not apply to the use of the alternate refrigerant approved by Taylor.

To find out the current status of an alternate refrigerant as it relates to your compressor warranty, call Taylor or your local authorized Taylor distributor. Be prepared to provide the model/serial number of the machine in question.

Note: *Continuing research results in steady improvements; therefore, information in this Operator Manual is subject to change without notice.*

We at Taylor Company are concerned about the safety of the operator when he or she comes in contact with the freezer and its parts. Taylor has gone to extreme efforts to design and manufacture built-in safety features to protect both the operator and the service technician. As an example, warning labels have been attached to the freezer to further point out safety precautions.



DANGER! Failure to adhere to the following safety precautions may result in severe personal injury or death. Failure to comply with these warnings may also damage the machine and/or its components. Such damage may require component replacement and service repair expenses.



NOTICE! DO NOT operate the machine without reading this entire manual first. Failure to follow all of these operating instructions may result in damage to the machine, poor performance, health hazards, or personal injury.



IMPORTANT! *This machine is to be used only by trained personnel. It is not intended for use, cleaning, or maintenance by children or people with reduced physical, sensory, or mental capabilities, or lack of experience and knowledge. Where limited machine operation is allowed for public use, such as a self-serve application, supervision or instruction concerning the use of the machine by a person responsible for their safety is required. Children should be supervised to ensure that they do not play with the machine.*



IMPORTANT! *An equipotential grounding lug is provided with this machine. Some countries require the grounding lug be properly attached to the rear of the frame by the authorized installer. The installation location is marked by the equipotential bonding symbol (5021 of IEC 60417-1) on both the removable panel and the machine's frame.*



WARNING! This machine must **NOT** be installed in an area where a water jet or hose can be used. **NEVER** use a water jet or hose to rinse or clean the machine. Failure to follow this instruction may result in electrocution.



WARNING! Avoid injury.

- **DO NOT** operate the machine unless it is properly grounded.
- **DO NOT** operate the machine with larger fuses than specified on the machine's data label.
- All repairs should be performed by an authorized Taylor service technician.
- The main power supplies to the machine must be disconnected prior to performing installation, repairs, or maintenance.
- **For Cord-Connected Machines:** Only authorized Taylor service technicians or licensed electricians may install a plug or replacement cord on the machine.
- Machines that are permanently connected to fixed wiring and for which leakage currents may exceed 10 mA, particularly when disconnected or not used for long periods, or during initial installation, shall have protective devices to protect against the leakage of current, such as a GFI, installed by the authorized personnel to the local codes.
- Stationary machines which are not equipped with a power cord and a plug or another device to disconnect the appliance from the power source must have an all-pole disconnecting device with a contact gap of at least 0.125 in. (3 mm) installed in the external installation.
- Supply cords used with this machine shall be oil-resistant, sheathed flexible cable not lighter than ordinary polychloroprene or other equivalent synthetic elastomer-sheathed cord (code designation 60245 IEC 57) installed with the proper cord anchorage to relieve conductors from strain, including twisting, at the terminals and protect the insulation of the conductors from abrasion.

SAFETY

- If the supply cord is damaged, it must be replaced by an authorized Taylor service technician in order to avoid a hazard.
- Secure the supply cord ground lead to the machine in a location where if the cord is pulled, the main power leads will become taut before the ground lead can break loose.

Failure to follow these instructions may result in electrocution. Contact your local authorized Taylor distributor for service.



WARNING! Avoid injury.

- **DO NOT** allow untrained personnel to operate this machine.
- **DO NOT** operate the machine unless all service panels and access doors are restrained with screws.
- **DO NOT** remove any internal operating parts (including, but not limited to, the freezer door, beater, or scraper blades), unless all control switches are in the OFF position.

Failure to follow these instructions may result in severe personal injury, especially to fingers or hands, from hazardous moving parts.



WARNING! This machine has many sharp edges that can cause severe injuries.

- **DO NOT** put objects or fingers in the door spout. This may contaminate the product and cause severe personal injury from blade contact.
- **USE EXTREME CAUTION** when removing the beater assembly. The scraper blades are very sharp.



IMPORTANT! Access to the service area of the machine must be restricted to persons having knowledge and practical experience with the machine, in particular as far as safety and hygiene are concerned.



CAUTION! This machine must be placed on a level surface. Extreme care should be taken when

moving the machine for any reason. Two or more persons are required to safely move this machine. Failure to comply may result in personal injury or damage to the machine.



NOTICE! Cleaning and sanitizing schedules are governed by your federal, state, or local regulatory agencies and must be followed accordingly. Please refer to the cleaning section of this manual for the proper procedure to clean this machine.



CAUTION! This machine is equipped with a refrigerated cabinet, designed to maintain product temperature at or below 40°F (4.4°C). Before replenishing the mix supply, the product must be refrigerated at or below 40°F (4.4°C). Failure to follow this instruction may result in health hazards and poor freezer performance.

DO NOT run the machine without product. Failure to follow this instruction can result in damage to the machine.

DO NOT obstruct air intake and discharge openings. A minimum of 3 in. (76 mm) of air clearance on both sides of the machine is required. It is recommended to place the rear of the machine against the wall to prevent the recirculation of warm air. Failure to follow this instruction may cause poor freezer performance and damage to the machine.

For Indoor Use Only: This machine is designed to operate indoors, under normal ambient temperatures of 70°F to 75°F (21°C to 24°C). The machine has successfully performed in high ambient temperatures of up to 104°F (40°C) at reduced capacities.

Noise Level: Airborne noise emission does not exceed 78 dB(A) when measured at a distance of 39 in. (1.0 m) from the surface of the machine and at a height of 62 in. (1.6 m) from the floor.

Model 490

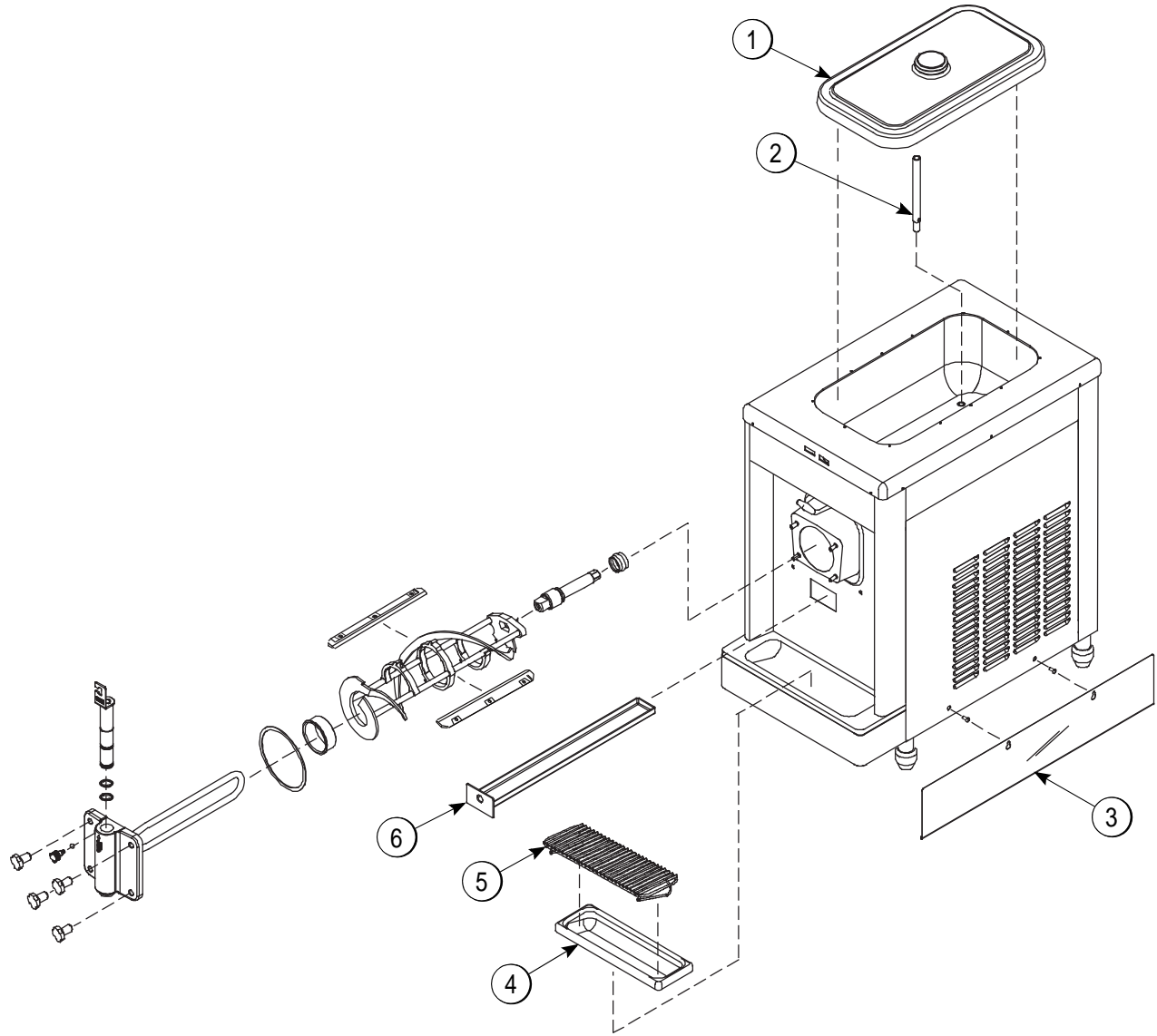

Figure 4-1

Item	Description	Part No.
1	Cover A.-Hopper	X51152
2	Tube-Feed-Non Revers	015176-9
3	Deflector-Air Skirt	067860

Item	Description	Part No.
4	Tray-Drip	046275
5	Shield-Splash-Wire	046177
6	Pan-Drip 19-1/2 L Black	035034

Beater Door Assembly

4

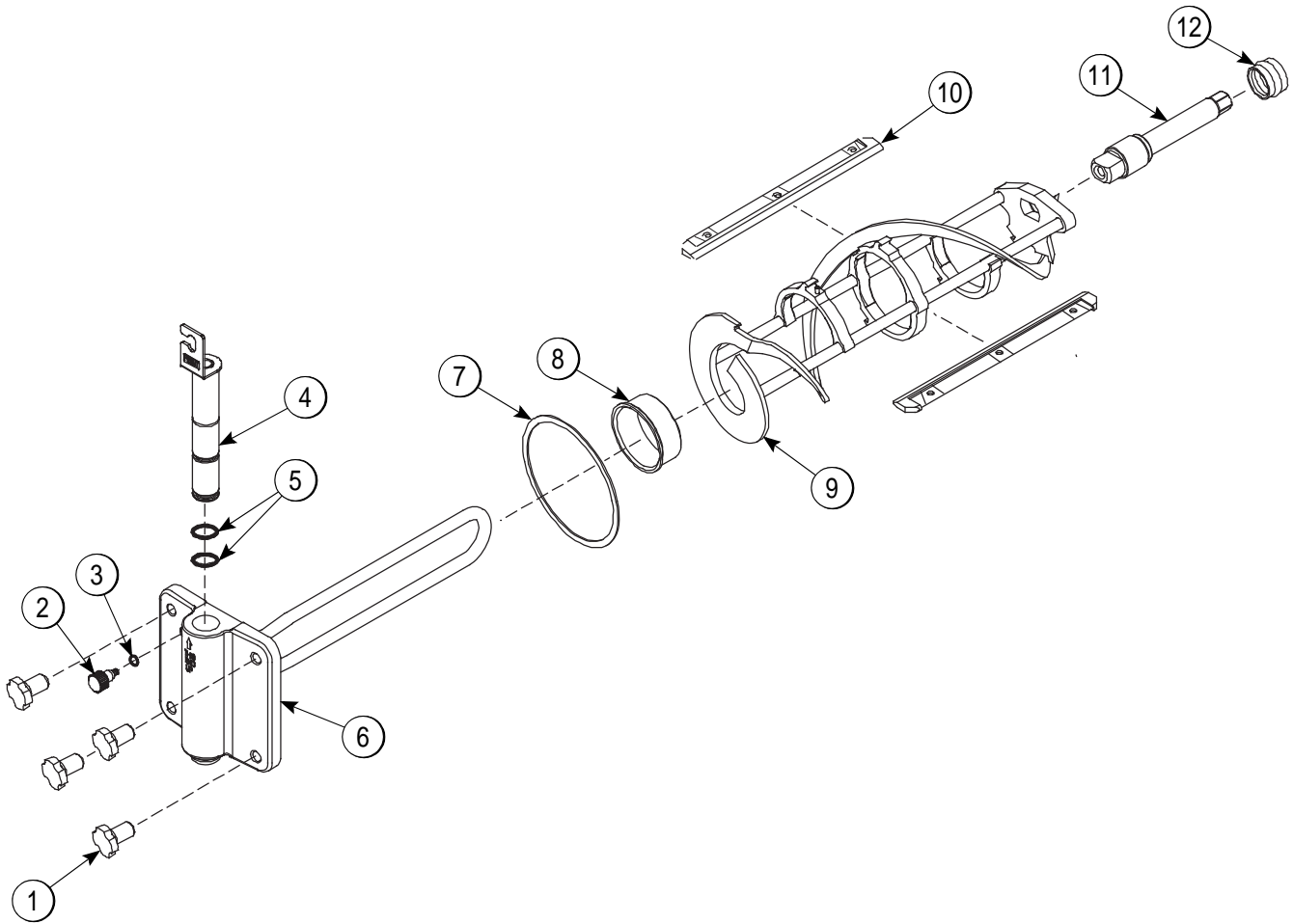
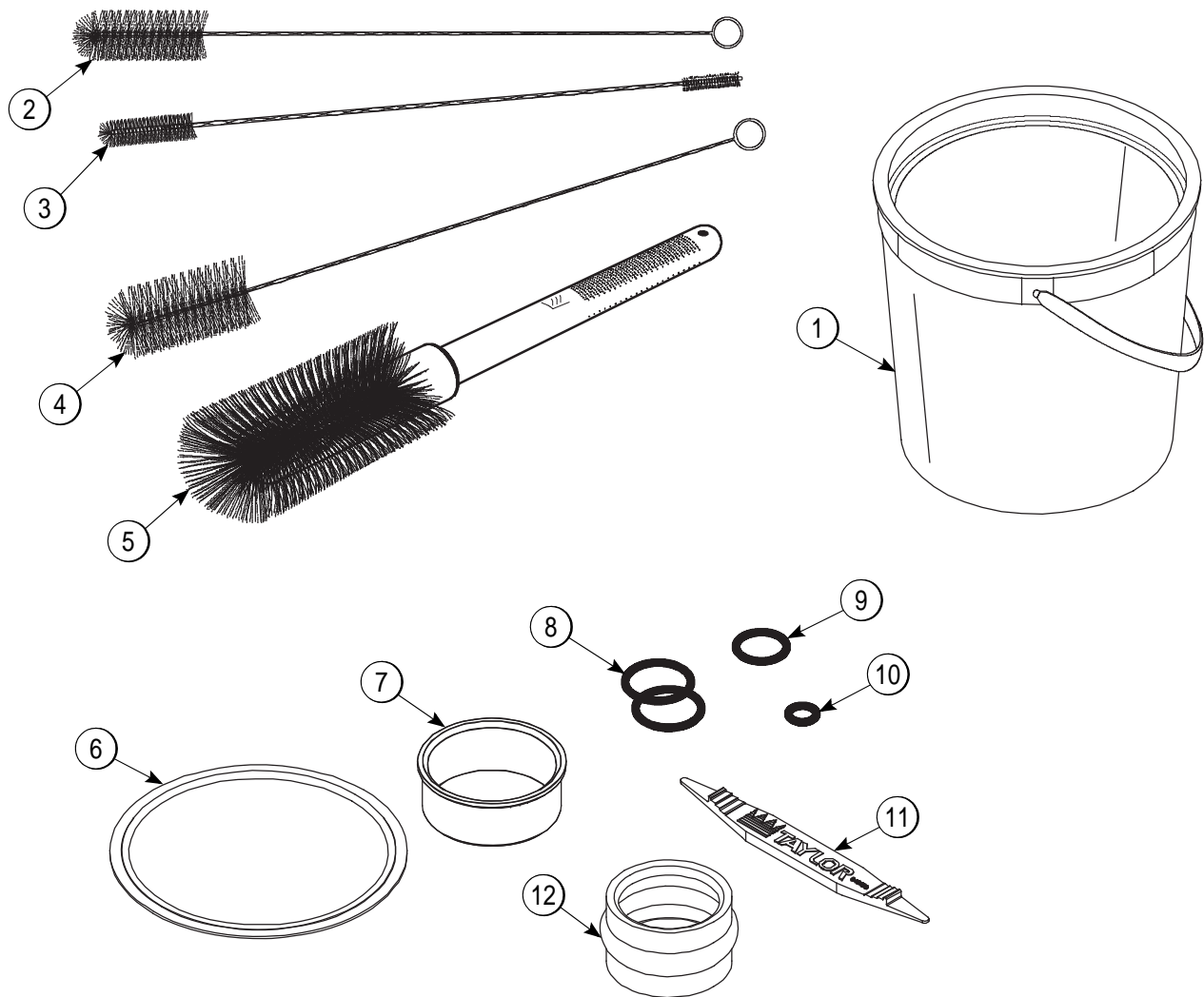

Figure 4-2

Item	Description	Part No.
1	Nut-Stud	021508
2	Plug-Prime	067779
3	O-ring-1/4 OD X .070W 50	015872
4	Valve A.-Draw	X48364
5	O-ring-1-1/16 OD X.139W	020571
6	Door A.-1 Spout-7 qt.	X67777-SER

Item	Description	Part No.
7	Gasket-Door 5.177ID X 5.938OD	016672
8	Bearing-Front	013116
9	Beater A.-7 qt.-1 Pin	X46233
10	Blade-Scraper-Plastic 9-13/16L	084950
11	Shaft-Beater	033498
12	Seal-Drive Shaft	032560

Accessories



4

Figure 4-3

Item	Description	Part No.
1	Pail-6 qt.	023348
2	Brush-Rear BRG 1IN.DX2IN	013071
3	Brush-Double Ended	013072
4	Brush-Draw Valve 1-1/2X3	014753
5	Brush-Mix Pump Body-3"X7 "	023316
*6	Gasket-Door 5.177 ID X 5.938 OD	016672

Item	Description	Part No.
*7	Bearing-Front	013116
*8	O-ring-1-1/16 OD X .139 W	020571
*9	O-ring-7/8 OD X .139 W	025307
*10	O-ring-1/4 OD X .070 W	015872
*11	Tool-O-ring Removal	048260-WHT
*12	Seal-Drive Shaft	032560

*Included in X67932 Tune-up kit

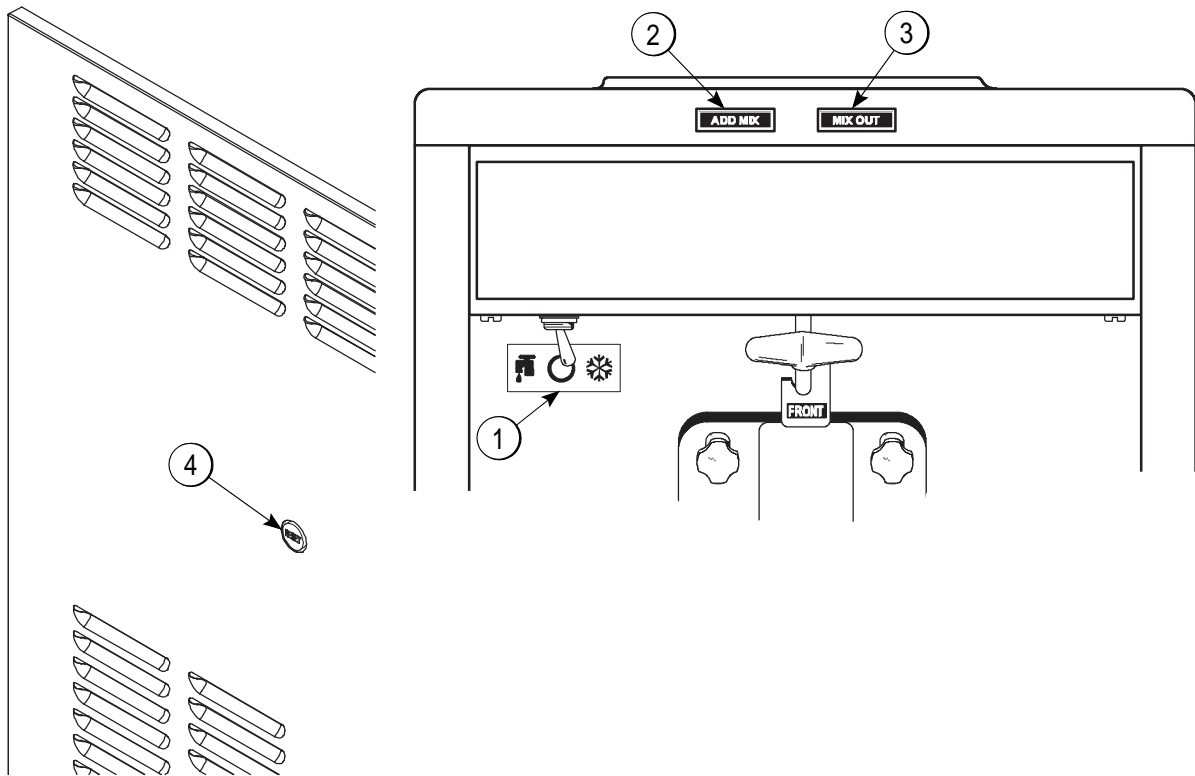

Figure 5-1

Table 5-1

Item	Description
1	Control Switch
2	ADD MIX Indicator
3	MIX OUT Indicator
4	RESET Button

Control Switch

The center position is off. The right position is auto, which activates the beater motor and the refrigeration system. The left position is wash, which activates the beater motor only.

Mix Level Indicators

The mix level indicators are located on the front of the machine. When the MIX LOW indicator is flashing, the mix hopper has a low supply of mix and should be refilled as soon as possible.

When the MIX OUT indicator is flashing, there is no mix in the hopper. The compressor stops running until the mix is replenished. This eliminates possible damage to the beater, blades, drive shaft, and door.

Reset Button

The reset button is located on the left side panel. The reset button protects the beater motor from overloading. If an overload occurs, the reset mechanism will trip.

To properly reset the freezer, place the control switch in the OFF position. Press the reset button firmly. Place the control switch in the WASH position and observe the freezer's performance. The beater motor should operate without tripping the overload. Once satisfied, place the control switch back in the AUTO position.

The Model 490 stores 20 qt. (18.9 L) of mix in the hopper. The mix flows **by gravity** through an air tube down into the freezing cylinder.

Instructions begin when we enter the store in the morning and find the parts disassembled and laid out to air dry from the previous night's cleaning.

The following procedures will show you how to assemble the parts into the freezer, sanitize them, and prime the freezer with **fresh** mix in preparation to serve your first product.

If you are disassembling the machine for the first time, or need information to get to this starting point in our instructions, turn to "Disassembly" on page 6-7 and start there.

Assembly

Note: When lubricating parts, use an approved food grade lubricant (example: Taylor Lube).

1. Lubricate the groove and the shaft portion that comes in contact with the bearing on the beater drive shaft. Slide the seal over the shaft and groove until it snaps into place. **Do not** lubricate the hex end of the drive shaft. Fill the inside portion of the seal with 1/4 in. (6.35 mm) more lubricant and evenly lubricate the flat side of the seal that comes in contact with the bearing.

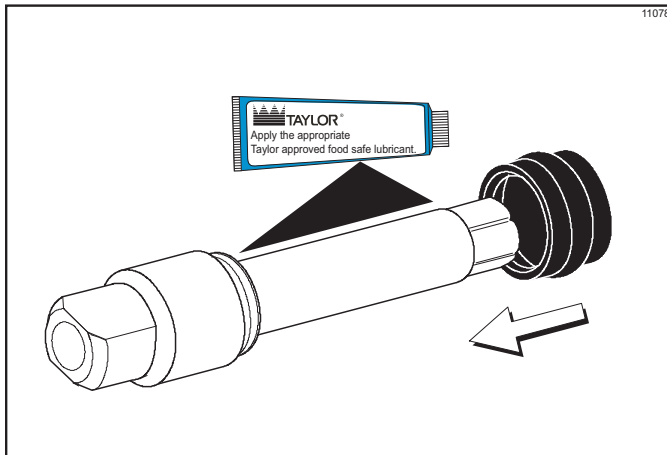

Figure 6-1

2. Insert the drive shaft through the rear shell bearing in the freezing cylinder and engage the hex end firmly into the gear box coupling.

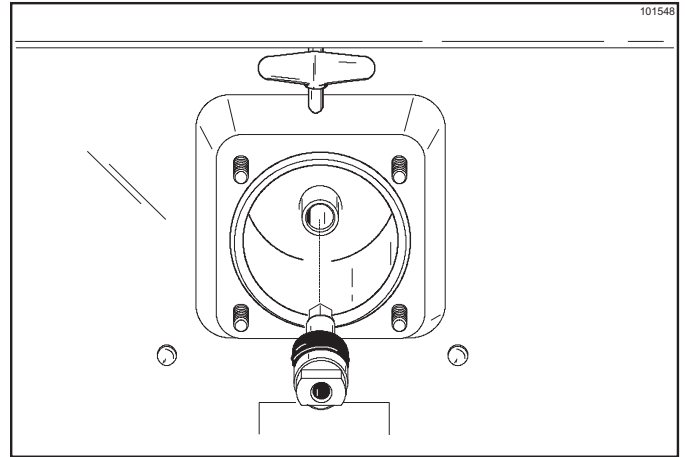

Figure 6-2



WARNING! Use extreme caution when handling the beater assembly. The scraper blades are very sharp and may cause injury.

3. Before installing the beater assembly, check the scraper blades for any signs of wear or damage. If a scraper blade is nicked or worn, replace both blades.

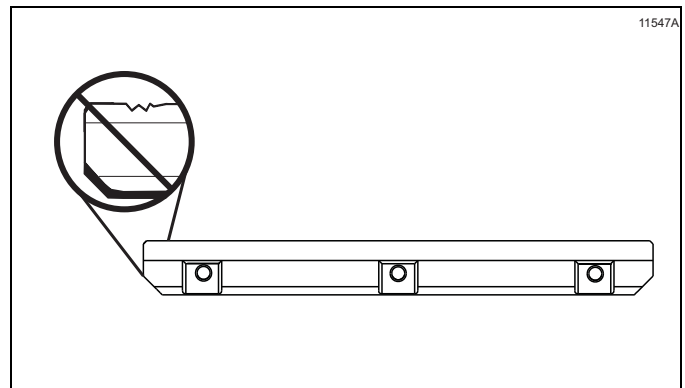

Figure 6-3

OPERATING PROCEDURES

- If the blades are in good condition, install the scraper blades. Place the rear scraper blade over the rear holding pin on the beater (knife edge to the outside).

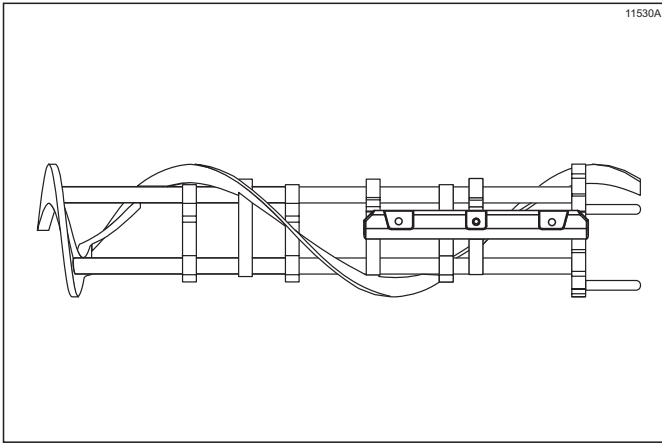

Figure 6-4

Note: To prevent damage, the hole on the scraper blade must fit securely over the pin.

- Holding the rear blade on the beater, slide the assembly into the freezing cylinder halfway, tail end first. Install the front scraper blade over the front holding pin. Slide the beater assembly completely into the freezing cylinder.

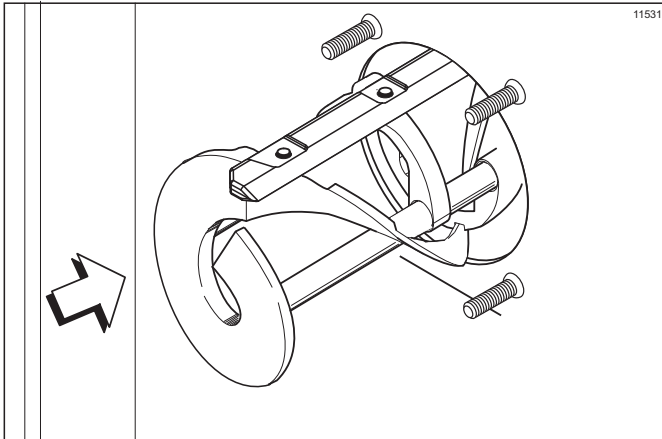

Figure 6-5

- Make sure the beater assembly is in position over the drive shaft. Turn the beater slightly to make sure the beater is properly seated. When in position, the beater will not protrude beyond the front of the freezing cylinder.

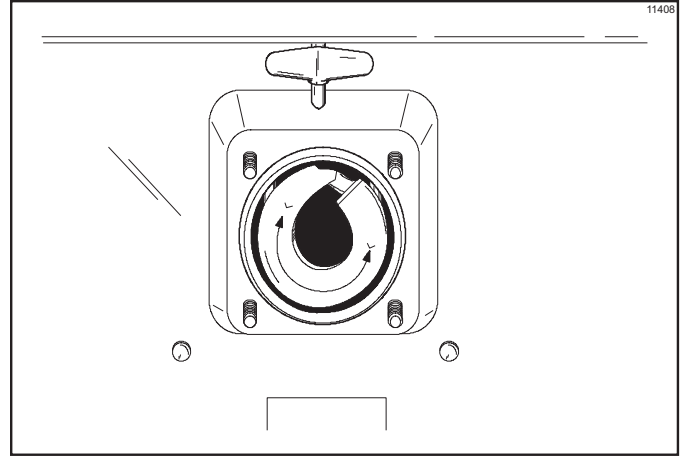

Figure 6-6

- Before assembling the freezer door, check the following for any nicks, cracks, or signs of wear: the front bearing, door gasket, draw valve, O-rings, and all sides of the door assembly, including the inside of the draw valve bore. Replace any damaged parts.
- Slide the two O-rings into the grooves on the draw valve and lubricate the bottom half of the valve.

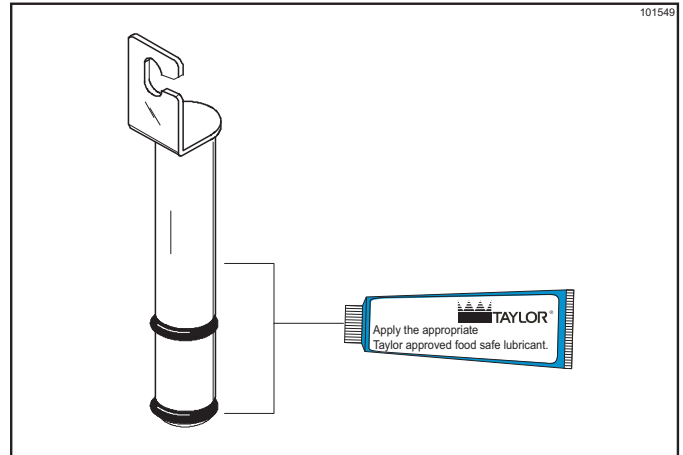

Figure 6-7

9. Lubricate the inside of the freezer door spout, top and bottom, and insert the draw valve into the freezer door from the top. It will be necessary to rotate the draw valve to the right when installing the door on the freezer.

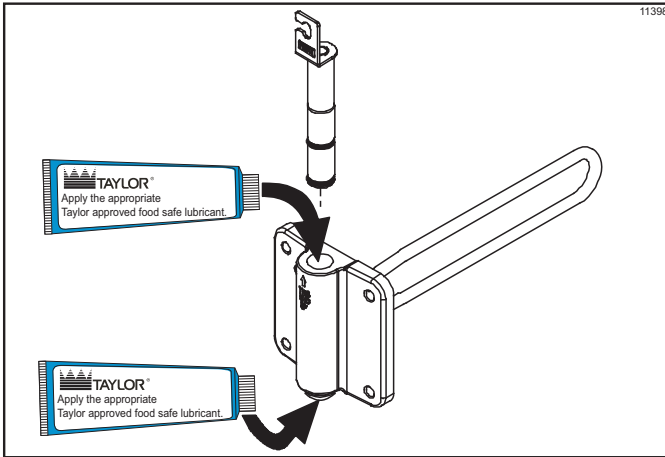

Figure 6-8

10. Place the O-ring onto the prime plug and lubricate.

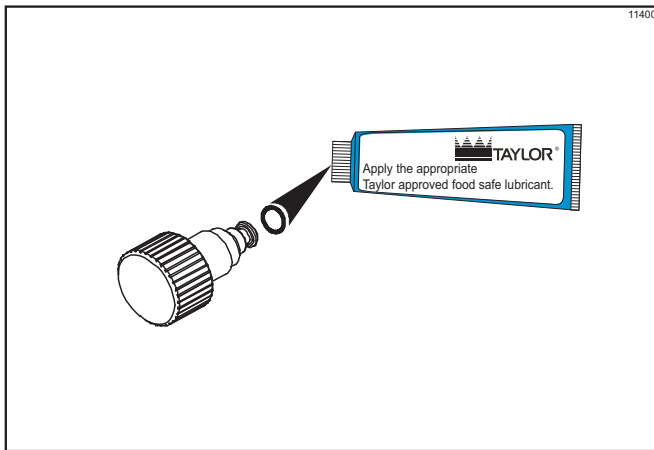

Figure 6-9

11. Screw the prime plug into position on the front of the door.

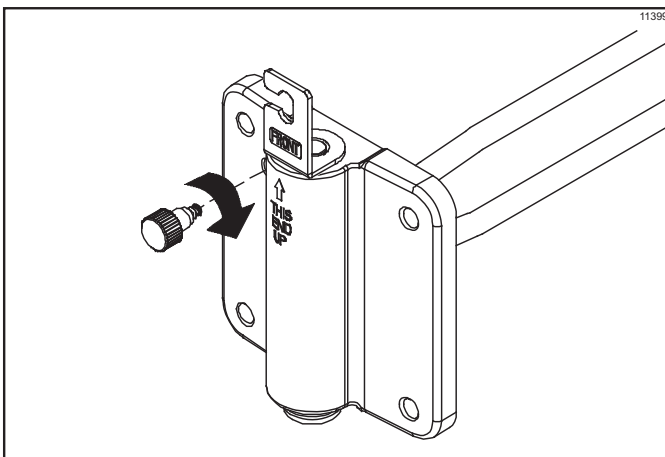

Figure 6-10

12. Place the freezer door gasket into the groove on the back of the freezer door. Slide the front bearing over the baffle rod so the flanged edge is against the door. **Important!** Do not lubricate the gasket or bearing.

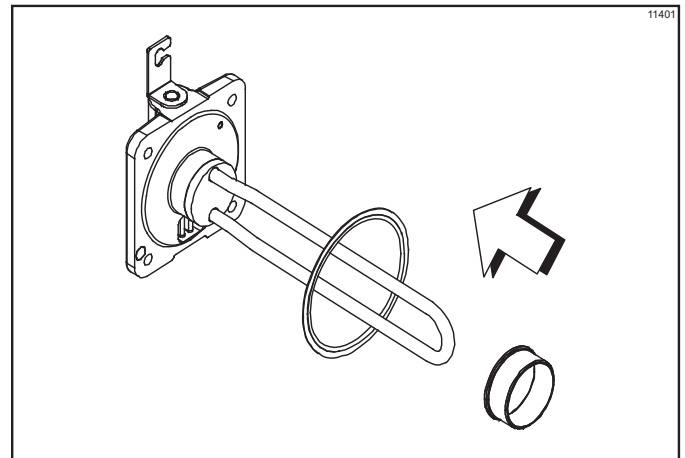

Figure 6-11

13. Insert the baffle rod through the beater in the freezing cylinder. With the door seated on the freezer studs, install the handscrews. Tighten equally in a crisscross pattern to ensure the door is secured.

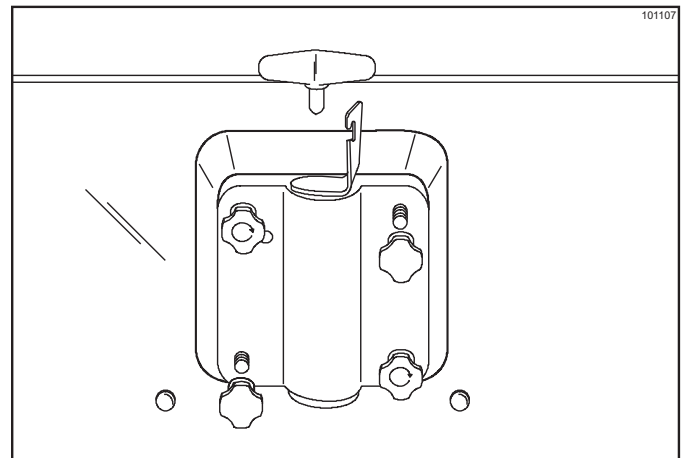

Figure 6-12

14. Rotate the draw valve bracket to the left and center it into position by raising the draw arm and placing it into the slotted groove of the draw valve bracket.

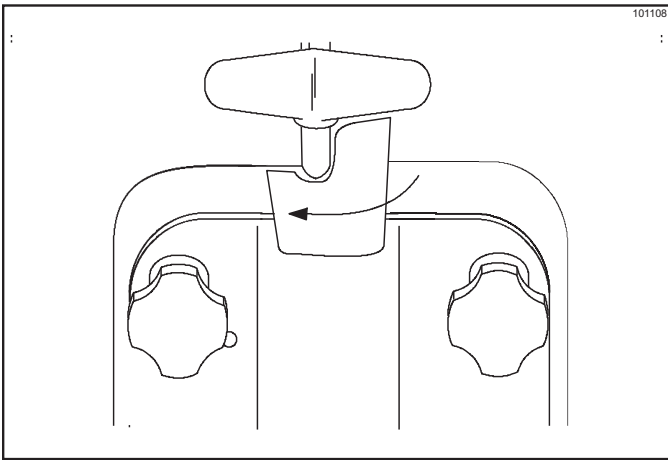

Figure 6-13

Note: The draw valve bracket must be positioned with the notch to the left.

15. Lay the air tube in the bottom of the mix hopper.

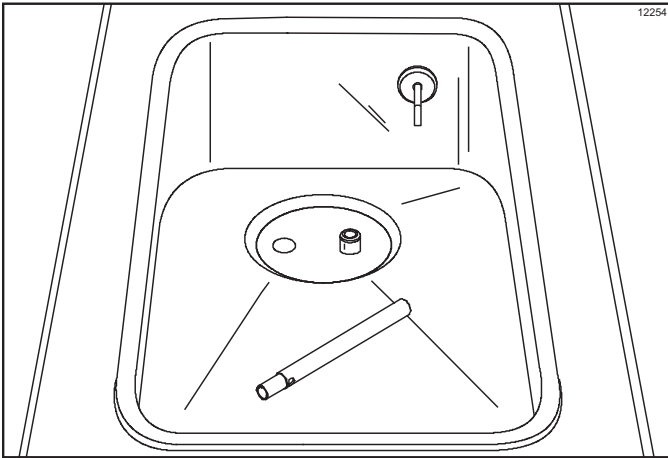

Figure 6-14

16. Slide the center drip pan into the hole in the front panel.

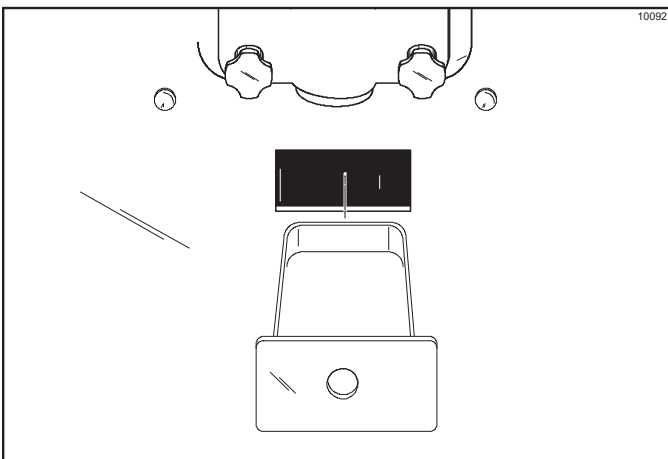

Figure 6-15

17. Install the front drip tray and splash shield under the door spout.

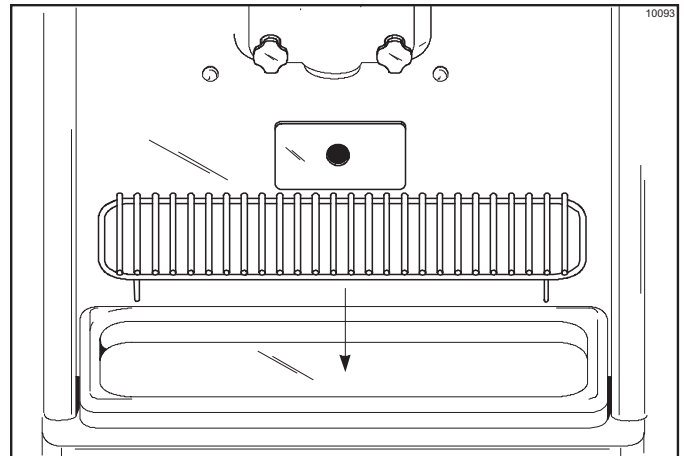

Figure 6-16

Sanitizing

1. Prepare an approved 100 PPM sanitizing solution (examples: 2-1/2 gal. [9.5 L] of Kay-5[®] or 2 gal. [7.6 L] of Stera-Sheen[®]).

Important! Use warm water and follow the manufacturer's specifications.

2. Pour the sanitizing solution into the hopper and allow it to flow into the freezing cylinder.

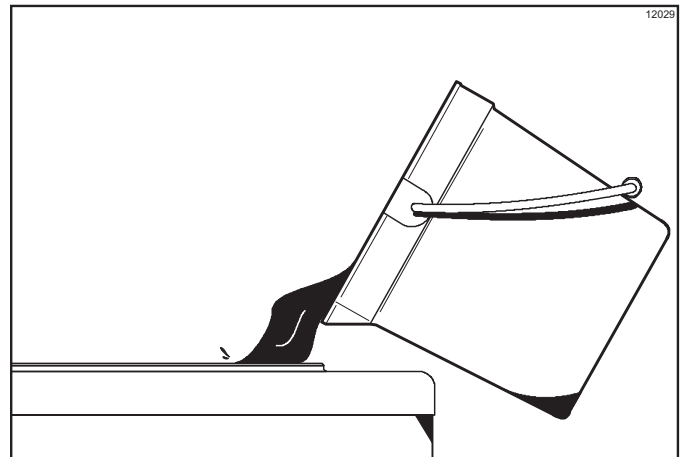

Figure 6-17

3. Open the prime plug on the door.

- While the solution is flowing into the freezing cylinder, brush clean the hopper.

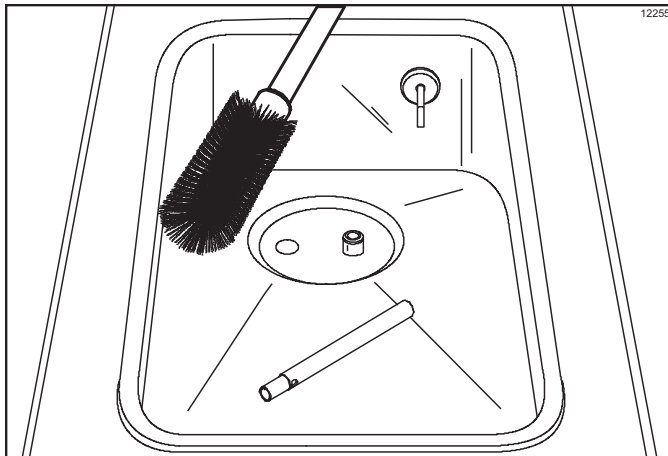

Figure 6-18

When cleaning the mix hopper, take particular care in brushing the mix-level sensing probes, the mix inlet hole and the air tube.

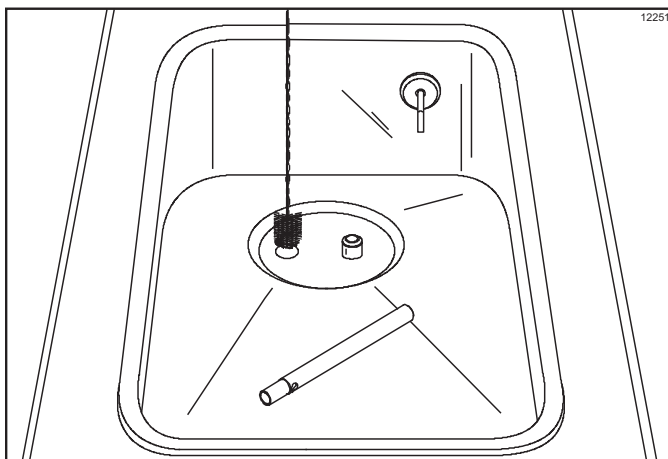

Figure 6-19

- When sanitizing solution starts leaking from the prime port, close the prime plug.

- Place the control switch in the WASH position. This will cause the sanitizing solution in the freezing cylinder to agitate. Allow the solution to agitate for 5 minutes.

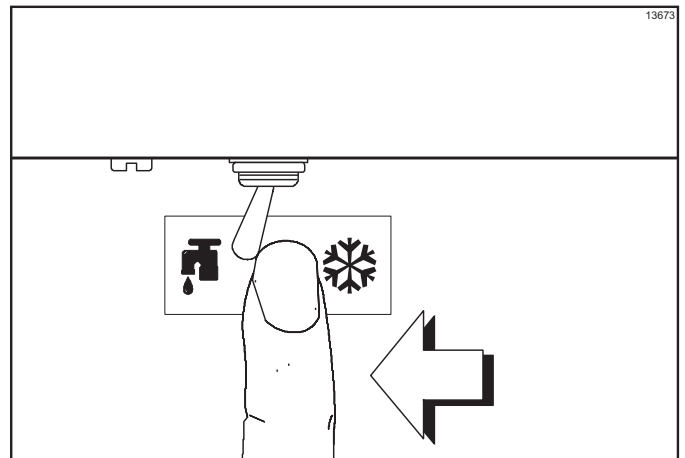

Figure 6-20

- Place an empty pail beneath the door spout and raise the draw arm. Draw off all the sanitizing solution. When the sanitizer stops flowing from the door spout, lower the draw arm and place the control switch in the OFF position.

Important! The machine must **not** be placed in Auto mode until all sanitizing solution has been removed from the freezing cylinder and proper priming procedures have been completed. Failure to follow this instruction may result in damage to the freezing cylinder.

Note: You have just sanitized the freezer. Therefore, make sure your hands are sanitized before performing the following step.

- Stand the air tube in the corner of the mix hopper.

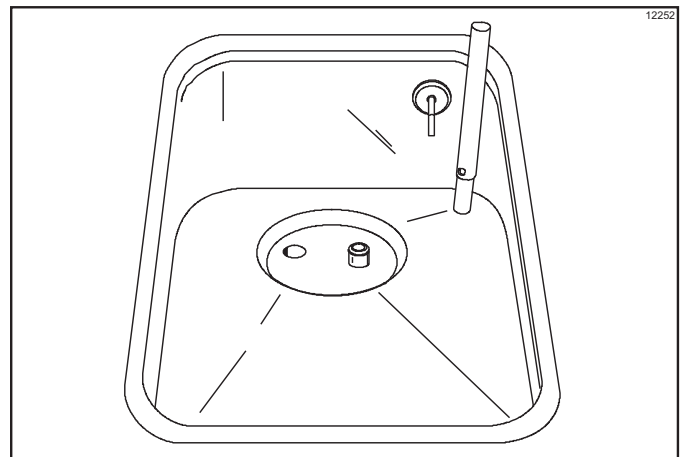

Figure 6-21

Priming

1. With a pail beneath the door spout, raise the draw arm. Pour 2 gal. (7.6 L) of **fresh** mix into the hopper and allow it to flow down into the freezing cylinder. This will force out any remaining sanitizing solution. When full-strength mix is flowing from the door spout, lower the draw arm.
 2. Open the prime plug by turning it counterclockwise until the air in the freezing cylinder is allowed to escape.
 3. When product starts flowing from the bleed port, close the prime plug by turning it clockwise until it is snug against the freezer door.
- Important!** Failure to remove all sanitizing solution may result in damage to the freezing cylinder.
4. Install the air tube in the mix inlet hole.

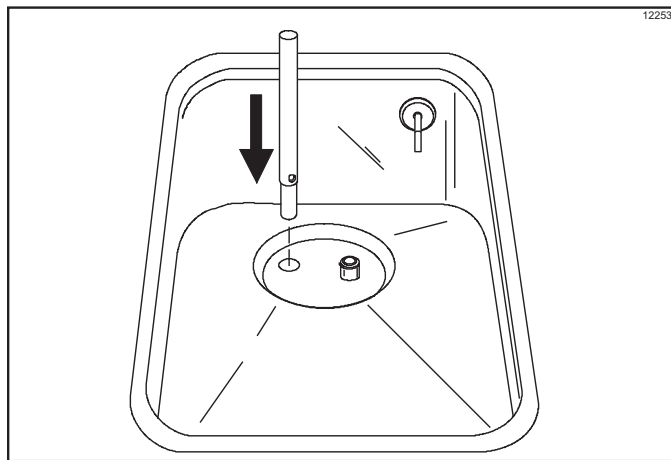

Figure 6-22

5. Fill the hopper with mix.
6. Place the control switch in the **Auto** position. Rotate the draw valve away from the draw arm as shown in Figure 6-23. Lift the draw arm to start the compressor.

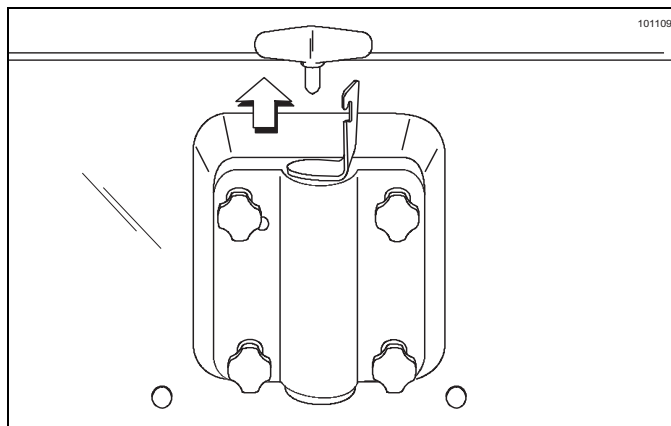

Figure 6-23

Rotate the draw valve back to its normal position on the draw arm. When the unit cycles off, the product will be at serving temperature.

7. Place the mix hopper cover in position.

Note: When drawing product, gently raise the draw arm to the fully opened position.

Closing Procedures

To disassemble the Model 490, the following items will be needed:

- Two cleaning pails
- NSF-approved sanitized stainless steel rerun can with lid
- Cleaning brushes (provided with freezer)
- Cleaner
- Single-service towels

Draining Product from the Freezing Cylinder

1. Place the control switch in the OFF position.
2. Remove the hopper cover and air tube. Take these items to the sink for cleaning.
3. **If local health codes permit the use of rerun**, place a sanitized, NSF approved stainless steel rerun container beneath the door spout. Place the control switch in the Wash position and raise the draw arm. When all the product stops flowing from the door spout, lower the draw arm and place the control switch in the OFF position. Place the sanitized lid on the rerun container and place it in the walk-in cooler. See page 7-1 for instructions regarding the proper use of rerun.

Note: If local health codes do not permit the use of rerun, the product must be discarded. Follow the instructions in the previous step, except drain the product into a pail and properly discard the mix.



Rinsing

1. Pour 2 gal. (7.6 L) of cool, clean water into the mix hopper. With the brushes provided, scrub the mix hopper, mix inlet hole, and mix-level sensing probes.
2. With a pail beneath the door spout, place the control switch in the Wash position and raise the draw arm. Drain all the rinse water from the freezing cylinder. When the rinse water stops flowing from the door spout, lower the draw arm and place the control switch in the OFF position.
Repeat this procedure until the rinse water being drawn from the freezing cylinder is clear.

Cleaning

1. Prepare an approved 100 PPM cleaning solution (examples: 2-1/2 gal. [9.5 L] of Kay-5[®] or 2 gal. [7.6 L] of Stera-Sheen[®]).
Important! Use warm water and follow the manufacturer's specifications.
2. Pour the cleaning solution into the hopper and allow it to flow into the freezing cylinder.
3. Open the prime plug on the door.
4. While the solution is flowing into the freezing cylinder, brush clean the mix hopper, mix inlet hole, and mix-level sensing probes.
5. When the solution starts leaking from the prime port, close the prime plug.
6. Place the control switch in the Wash position. This will cause the cleaning solution in the freezing cylinder to agitate.
7. Place an empty pail beneath the door spout and raise the draw arm. Draw off all the cleaning solution. When the solution stops flowing from the door spout, lower the draw arm and place the control switch in the OFF position.

Disassembly

Note: Failure to remove, brush clean, and air dry these items will result in damage to the related components.

1. Make sure the control switch is placed in the OFF position.
2. Remove the handscrews, freezer door, gasket, front bearing, beater, scraper blades, and drive shaft from the freezing cylinder. Take these items to the sink for cleaning.
3. Remove the drip pan from the machine.
Note: If the drip pan is filled with an excessive amount of mix, the drive shaft seal and O-ring should be replaced or was improperly lubricated.
4. Remove the front drip tray and splash shield.

Brush Cleaning

1. Prepare a sink with an approved 100 PPM cleaning solution (examples: Kay-5[®] or Stera-Sheen[®]).
Important! Use warm water and follow the manufacturer's specifications.
If an approved cleaner other than Kay-5[®] or Stera-Sheen[®] is used, dilute according to the manufacturer's instructions.
Important! Follow label directions. Too **strong** of a solution can cause parts damage, while too **mild** of a solution will not provide adequate cleaning. Make sure all brushes provided with the freezer are available for brush cleaning.
2. Remove the seal from the drive shaft.
3. Remove the draw valve and prime plug from the freezer door. Remove the two O-rings from the draw valve and the O-ring from the prime plug.
Note: To remove O-rings, use a single-service towel to grasp the O-ring. Apply pressure in an upward direction until the O-ring pops out of its groove. With the other hand, push the top of the O-ring forward; it will roll out of the groove and can be easily removed. If there is more than one O-ring to be removed, always remove the rear O-ring first. This will allow the O-ring to slide over the forward O-rings without falling into the open grooves.

OPERATING PROCEDURES

4. Thoroughly brush clean all disassembled parts in the cleaning solution, making sure all lubricant and mix film is removed. Take particular care to brush clean the draw valve core in the freezer door. Place all the cleaned parts on a clean, dry surface to air dry overnight.
5. Return to the freezer with a small amount of cleaning solution. With the black bristle brush, brush clean the rear shell bearing at the back of the freezing cylinder.

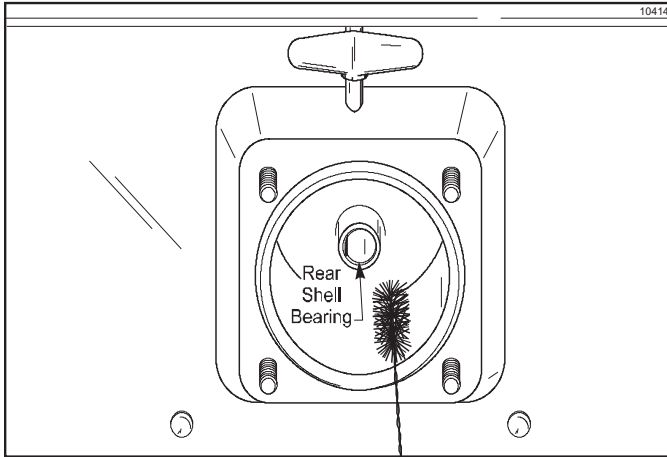

Figure 6-24

6. Using single-service towels, wipe clean all exterior surfaces of the freezer.

6

During Cleaning and Sanitizing



ALWAYS FOLLOW LOCAL HEALTH CODES.

Cleaning and sanitizing schedules are governed by federal, state, or local regulatory agencies, and must be followed accordingly. If the machine has a **Standby mode**, it must not be used instead of proper cleaning and sanitizing procedures and frequencies set forth by the ruling health authority. The following checkpoints should be stressed during the cleaning and sanitizing operations.



IMPORTANT! *Cleaning and sanitizing must be performed daily.*

Troubleshooting Bacterial Count

- Thoroughly clean and sanitize the machine regularly, including complete disassembly and brush cleaning.
- Use all brushes supplied for thorough cleaning. The brushes are specially designed to reach all mix passageways.
- Use the white bristle brush to clean the mix feed tube which extends from the hopper up to the rear of the freezing cylinder.
- Use the black bristle brush to thoroughly clean the rear shell bearing located at the rear of the freezing cylinder. Use a generous amount of cleaning solution on the brush.
- If local health codes permit the use of rerun**, make sure the mix rerun is stored in a sanitized, covered, NSF-approved stainless steel rerun container and used the following day. **Do not** prime the machine with rerun. When using rerun, skim off the foam and discard; then mix the rerun with **fresh** mix in a ratio of 50:50 during the day's operation.
- Properly prepare the cleaning and sanitizing solutions. Read and follow label directions carefully. Too **strong** of a solution may damage

the parts, and too **weak** of solution may not do an adequate job of cleaning or sanitizing.

- The temperature of the mix in the mix hopper and walk-in cooler should be below 40°F (4.4°C).

Regular Maintenance Checks

- Rotate the scraper blades to allow both sides of the knife edge to wear evenly. This will contribute to self-sharpening and help maintain fast, efficient freezing.
 - Replace scraper blades that are bent, damaged, or worn down.
 - Before installing the beater, make sure the scraper blades are properly attached over the beater pins.
 - Dispose of O-rings and seals that are worn, torn, or fit too loosely, and replace them.
 - Check the rear shell bearing for signs of wear (excessive mix leakage in rear drip pan) and make sure it is properly cleaned.
 - Using a screwdriver and cloth towel, keep the female drive socket and the rear shell bearing free of lubricant and mix deposits.
 - Follow all lubricating procedures as outlined in "Assembly" on page 6-1.
 - On air-cooled machines, check the condenser for an accumulation of dirt and lint. Dirty condensers will reduce the efficiency and capacity of the machine. The condensers should be cleaned **monthly**. Remove the side panels to gain access to the condensers. Use a soft brush to clean between the fins of the condenser. **Never** use screwdrivers or other metal probes to clean between the fins.
- Note:** *For machines equipped with an air filter, it will be necessary to vacuum clean the filters on a monthly schedule.*
- On water-cooled machines, check the water lines for kinks or leaks. Kinks can occur when the machine is moved back and forth for cleaning or maintenance purposes. Deteriorated or cracked water lines should be replaced only by an authorized Taylor technician.

Winter Storage

To protect the freezer during the winter months when the place of business is closed, it is important that certain precautions be followed, particularly if the building is to be left unheated and subject to freezing conditions.

Disconnect the freezer from the main power source to prevent possible electrical damage.

On water-cooled machines, disconnect the water supply. Use air pressure to blow out any remaining water in the condensers. **This is extremely important.** Failure to follow this procedure can cause severe and costly damage to the refrigeration system.

Your local Taylor distributor can perform this service for you.

Wrap detachable parts of the freezer such as the beater assembly and freezer door and place them in a protected, dry place. Rubber trim parts and gaskets can be protected by wrapping them with moisture proof paper. All parts should be thoroughly cleaned of dried mix or lubrication accumulations, which can attract mice and other vermin.

Table 8-1

Problem	Probable Cause	Remedy	Page Ref.
1. No product being dispensed (draw valve open and machine in Auto mode).	a. Freeze-up in the mix inlet hole.	a. Call service technician to adjust mix hopper temperature.	---
	b. Beater motor out on reset.	b. Allow the motor to cool and then press the reset button.	5-1
	c. Beater rotating counterclockwise from operator end.	c. Contact service technician to correct rotation to clockwise from operator end.	---
	d. Circuit breaker off or blown fuse.	d. Turn breaker on or replace fuse.	---
	e. Inadequate mix in the mix hopper.	e. Fill mix hopper with mix.	6-6
2. Product too stiff.	a. TQC control is set incorrectly.	a. Contact service technician.	---
	b. Inadequate mix in hopper.	b. Fill hopper with mix.	6-6
3. Product too soft.	a. TQC control is set incorrectly.	a. Contact service technician.	---
	b. Not enough air space around machine.	b. Allow for adequate air flow across the condenser.	1-2
	c. Worn scraper blades.	c. Replace regularly.	7-1
	d. Dirty condenser.	d. Clean monthly.	7-2
	e. Out-of-date mix.	e. Use only fresh mix.	---
4. Mix in mix hopper too cold.	a. EPR valve is out of adjustment.	a. Call service technician.	---
5. Mix in mix hopper too warm.	a. EPR valve is out of adjustment.	a. Call service technician.	---
	b. Warm mix placed in hopper.	b. Mix should be below 40°F (4.4°C) when placed in hopper.	7-1
	c. Mix hopper cover is not in position.	c. Place cover in position.	6-6
6. Drive shaft stuck in the drive coupling.	a. Rounded corners of drive shaft, coupling, or both.	a. Call service technician to correct cause and replace necessary components. Do not lubricate hex end of drive shaft.	---
	b. Misalignment of rear bearing plate.	b. Contact service technician.	---
7. The freezing cylinder walls are scored.	a. The scraper blades are damaged.	a. Replace the scraper blades.	6-1
	b. The front bearing is missing or worn on the freezer door.	b. Install or replace the front bearing.	6-3
	c. Machine was placed in Auto before all sanitizing solution was removed from freezing cylinder.	c. Place machine in Auto only after priming is complete and all sanitizing solution is removed.	6-4
	d. Broken pins on beater assembly.	d. Repair or replace the beater assembly. Make sure the scraper blades are properly seated on pins.	6-2
	e. The beater assembly is bent.	e. Call service technician to repair or replace the beater and to correct the cause of insufficient mix in the freezing cylinder.	---

TROUBLESHOOTING GUIDE

Problem	Probable Cause	Remedy	Page Ref.
8. Excessive mix leakage into drive shaft drip pan.	a. Missing or worn drive shaft seal on drive shaft.	a. Install or replace regularly.	6-1 / 9-1
	b. Drive shaft seal installed inside out.	b. Install seal properly.	6-1
	c. Worn rear shell bearing.	c. Call service technician to replace rear shell bearing.	- - -
9. Excessive mix leakage from door spout.	a. Missing or worn draw valve O-rings.	a. Install or replace regularly.	6-2 / 9-1
	b. Inadequate lubrication of draw valve O-rings.	b. Lubricate properly.	6-2
	c. Wrong type lubricant being used (example: petroleum-based lubricant).	c. Use proper lubricant (example: Taylor Lube).	6-1
10.No freezer operation after placing the machine in Auto.	a. Machine unplugged.	a. Plug into wall receptacle.	- - -
	b. Circuit breaker off, or blown fuse.	b. Turn breaker on, or replace fuse.	- - -
	c. Beater motor out on reset.	c. Allow the motor to cool and then press the reset button.	5-1
	d. The draw arm is not activated.	d. After placing the freezer in the Auto mode, the draw arm must be raised to activate the Auto cycle.	6-6
11.Product not feeding into freezing cylinder.	a. Inadequate level of mix in the mix hopper.	a. Fill the mix hopper with mix.	6-6
	b. Mix inlet hole frozen.	b. Mix hopper temperature needs adjustment. Call service technician.	- - -

Table 9-1

Part Description	Every 3 Months	Every 6 Months	Annually
Scraper Blade	X		
Drive Shaft Seal	X		
Draw Valve O-Rings	X		
Prime Plug O-Ring	X		
Freezer Door Gasket	X		
Front Bearing	X		
White Bristle Brush, 3" x 7"		Inspect and replace if necessary.	Minimum
White Bristle Brush, 1-1/2" x 3"		Inspect and replace if necessary.	Minimum
Black Bristle Brush, 1" x 2"		Inspect and replace if necessary.	Minimum
Double-Ended Brush		Inspect and replace if necessary.	Minimum

TAYLOR COMPANY LIMITED WARRANTY ON FREEZERS

Taylor Company is pleased to provide this limited warranty on new Taylor-branded freezer equipment available from Taylor to the market generally (the "Product") to the original purchaser only.

LIMITED WARRANTY

Taylor warrants the Product against failure due to defect in materials or workmanship under normal use and service as follows. All warranty periods begin on the date of original Product installation. If a part fails due to defect during the applicable warranty period, Taylor, through an authorized Taylor distributor or service agency, will provide a new or remanufactured part, at Taylor's option, to replace the failed defective part at no charge for the part. Except as otherwise stated herein, these are Taylor's exclusive obligations under this limited warranty for a Product failure. This limited warranty is subject to all provisions, conditions, limitations, and exclusions listed below and on the reverse (if any) of this document.

Table 10-1

Product	Part	Limited Warranty Period
Soft Serve	Insulated shell assembly	Five (5) years
Frozen Yogurt Shakes	Refrigeration compressor (except service valve)	Five (5) years
Smoothies	Beater motors	Two (2) years
Frozen Beverage	Beater drive gear	Two (2) years
Batch Desserts	Printed circuit boards and Softech controls beginning with serial number H8024200	Two (2) years
	Parts not otherwise listed in this table or excluded below	One (1) years

LIMITED WARRANTY CONDITIONS

1. If the date of original installation of the Product cannot be verified, then the limited warranty period begins ninety (90) days from the date of Product manufacture (as indicated by the Product serial number). Proof of purchase may be required at time of service.
2. This limited warranty is valid only if the Product is installed and all required service work on the Product is performed by an authorized Taylor distributor or service agency, and only if genuine, new Taylor parts are used.
3. Installation, use, care, and maintenance must be normal and in accordance with all instructions contained in the Taylor Operator's Manual.
4. Defective parts must be returned to the authorized Taylor distributor or service agency for credit.
5. The use of any refrigerant other than that specified on the Product's data label will void this limited warranty.

LIMITED WARRANTY EXCEPTIONS

This limited warranty does **not** cover:

1. Labor or other costs incurred for diagnosing, repairing, removing, installing, shipping, servicing, or handling of defective parts, replacement parts, or new Products.
2. Normal maintenance, cleaning, and lubrication as outlined in the Taylor Operator's Manual, including cleaning of condensers.
3. Replacement of wear items designated as Class "000" parts in the Taylor Operator's Manual.
4. External hoses, electrical power supplies, and machine grounding.

LIMITED WARRANTY ON EQUIPMENT

5. Parts not supplied or designated by Taylor, or damages resulting from their use.
6. Return trips or waiting time required because a service technician is prevented from beginning warranty service work promptly upon arrival.
7. Failure, damage, or repairs due to faulty installation, misapplication, abuse, no or improper servicing, unauthorized alteration, or improper operation or use as indicated in the Taylor Operator's Manual, including but not limited to the failure to use proper assembly and cleaning techniques, tools, or approved cleaning supplies.
8. Failure, damage, or repairs due to theft, vandalism, wind, rain, flood, high water, water, lightning, earthquake, or any other natural disaster, fire, corrosive environments, insect or rodent infestation, or other casualty, accident, or condition beyond the reasonable control of Taylor; operation above or below the electrical or water supply specification of the Product; or components repaired or altered in any way so as, in the judgment of the Manufacturer, to adversely affect performance, or normal wear or deterioration.
9. Any Product purchased over the Internet.
10. Failure to start due to voltage conditions, blown fuses, open circuit breakers, or damages due to the inadequacy or interruption of electrical service.
11. Electricity or fuel costs, or increases in electricity or fuel costs from any reason whatsoever.
12. Damages resulting from the use of any refrigerant other than that specified on the Product's data label will void this limited warranty.
13. Any cost to replace, refill, or dispose of refrigerant, including the cost of refrigerant.
14. **ANY SPECIAL, INDIRECT, OR CONSEQUENTIAL PROPERTY OR COMMERCIAL DAMAGE OF ANY NATURE WHATSOEVER.** Some jurisdictions do not allow the exclusion of incidental or consequential damages, so this limitation may not apply to you.

This limited warranty gives you specific legal rights, and you may also have other rights which vary from jurisdiction to jurisdiction.

LIMITATION OF WARRANTY

THIS LIMITED WARRANTY IS EXCLUSIVE AND IS IN LIEU OF ALL OTHER WARRANTIES, CONDITIONS, AND/OR REMEDIES UNDER THE LAW, INCLUDING ANY IMPLIED WARRANTIES OR CONDITIONS OF MERCHANTABILITY OR FITNESS FOR A PARTICULAR PURPOSE. THE ORIGINAL OWNER'S SOLE REMEDY WITH RESPECT TO ANY PRODUCTS SHALL BE REPAIR OR REPLACEMENT OF DEFECTIVE COMPONENTS UNDER THE TERMS OF THIS LIMITED WARRANTY. ALL RIGHTS TO CONSEQUENTIAL OR INCIDENTAL DAMAGES (INCLUDING CLAIMS FOR LOST SALES, LOST PROFITS, PRODUCT LOSS, PROPERTY DAMAGES, OR SERVICE EXPENSES) ARE EXPRESSLY EXCLUDED. THE EXPRESS WARRANTIES MADE IN THIS LIMITED WARRANTY MAY NOT BE ALTERED, ENLARGED, OR CHANGED BY ANY DISTRIBUTOR, DEALER, OR OTHER PERSON, WHATSOEVER.

LEGAL REMEDIES

The owner **must** notify Taylor in writing, by certified or registered letter to the following address, of any defect or complaint with the Product, stating the defect or complaint and a specific request for repair, replacement, or other correction of the Product under warranty, mailed at least thirty (30) days before pursuing any legal rights or remedies.

Taylor Company
750 N. Blackhawk Blvd.
Rockton, IL 61072, U.S.A.

TAYLOR COMPANY LIMITED WARRANTY ON GENUINE TAYLOR PARTS

Taylor Company is pleased to provide this limited warranty on new Taylor genuine replacement components and parts available from Taylor to the market generally (the "Parts") to the original purchaser only.

LIMITED WARRANTY

Taylor warrants the Parts against failure due to defect in materials or workmanship under normal use and service as follows. All warranty periods begin on the date of original installation of the Part in the Taylor unit. If a Part fails due to defect during the applicable warranty period, Taylor, through an authorized Taylor distributor or service agency, will provide a new or remanufactured Part, at Taylor's option, to replace the failed defective Part at no charge for the Part. Except as otherwise stated herein, these are Taylor's exclusive obligations under this limited warranty for a Part failure. This limited warranty is subject to all provisions, conditions, limitations, and exclusions listed below and on the reverse (if any) of this document.

Table 11-1

Parts Warranty Class Code or Part	Limited Warranty Period
Class 103 Parts ¹	Three (3) Months
Class 212 Parts ²	Twelve (12) Months
Class 512 Parts	Twelve (12) Months
Class 000 Parts	No Warranty

LIMITED WARRANTY CONDITIONS

1. If the date of original installation of the Part cannot be otherwise verified, proof of purchase may be required at time of service.
2. This limited warranty is valid only if the Part is installed and all required service work in connection with the Part is performed by an authorized Taylor distributor or service agency.
3. The limited warranty applies only to Parts remaining in use by their original owner at their original installation location in the unit of original installation.
4. Installation, use, care, and maintenance must be normal and in accordance with all instructions contained in the Taylor Operator's Manual.
5. Defective Parts must be returned to the authorized Taylor distributor or service agency for credit.
6. This warranty is not intended to shorten the length of any warranty coverage provided pursuant to a separate Taylor Limited Warranty on freezer or grill equipment.
7. The use of any refrigerant other than that specified for the unit in which the Part is installed will void this limited warranty.

^{1, 2} Except that Taylor Part #032129SER2 (Compressor-Air-230V SERV) and Taylor Part #075506SER1 (Compressor-Air-115V 60HZ) shall have a limited warranty period of twelve (12) months when used in Taylor freezer equipment and a limited warranty period of two (2) years when used in Taylor grill equipment.

LIMITED WARRANTY ON PARTS

LIMITED WARRANTY EXCEPTIONS

This limited warranty does **not** cover:

1. Labor or other costs incurred for diagnosing, repairing, removing, installing, shipping, servicing, or handling of defective Parts, replacement Parts, or new Parts.
2. Normal maintenance, cleaning, and lubrication as outlined in the Taylor Operator's Manual, including cleaning of condensers or carbon and grease buildup.
3. Required service, whether cleaning or general repairs, to return the cooking surface assemblies, including the upper platen and lower plate, to an operational condition to achieve proper cooking or allow proper assembly of release sheets and clips as a result of grease buildup on the cooking surfaces, including but not limited to the platen and plate, sides of the shroud, or top of the shroud.
4. Replacement of cooking surfaces, including the upper platen and lower plate, due to pitting or corrosion (or in the case of the upper platen, due to loss of plating) as a result of damage due to the impact of spatulas or other small wares used during the cooking process or as a result of the use of cleaners, cleaning materials, or cleaning processes not approved for use by Taylor.
5. Replacement of wear items designated as Class "000" Parts in the Taylor Operator's Manual, as well as any release sheets and clips for the Product's upper platen assembly.
6. External hoses, electrical power supplies, and machine grounding.
7. Parts not supplied or designated by Taylor, or damages resulting from their use.
8. Return trips or waiting time required because a service technician is prevented from beginning warranty service work promptly upon arrival.
9. Failure, damage, or repairs due to faulty installation, misapplication, abuse, no or improper servicing, unauthorized alteration, or improper operation or use as indicated in the Taylor Operator's Manual, including but not limited to the failure to use proper assembly and cleaning techniques, tools, or approved cleaning supplies.
10. Failure, damage, or repairs due to theft, vandalism, wind, rain, flood, high water, water, lightning, earthquake, or any other natural disaster, fire, corrosive environments, insect or rodent infestation, or other casualty, accident, or condition beyond the reasonable control of Taylor; operation above or below the gas, electrical, or water supply specification of the unit in which a part is installed; or Parts or the units in which they are installed repaired or altered in any way so as, in the judgment of Taylor, to adversely affect performance, or normal wear or deterioration.
11. Any Part purchased over the Internet.
12. Failure to start due to voltage conditions, blown fuses, open circuit breakers, or damages due to the inadequacy or interruption of electrical service.
13. Electricity, gas, or other fuel costs, or increases in electricity or fuel costs from any reason whatsoever.
14. Damages resulting from the use of any refrigerant other than that specified for the unit in which the Part is installed will void this limited warranty.
15. Any cost to replace, refill, or dispose of refrigerant, including the cost of refrigerant.
16. **ANY SPECIAL, INDIRECT, OR CONSEQUENTIAL PROPERTY OR COMMERCIAL DAMAGE OF ANY NATURE WHATSOEVER.** Some jurisdictions do not allow the exclusion of incidental or consequential damages, so this limitation may not apply to you.

This limited warranty gives you specific legal rights, and you may also have other rights which vary from jurisdiction to jurisdiction.

LIMITATION OF WARRANTY

THIS LIMITED WARRANTY IS EXCLUSIVE AND IS IN LIEU OF ALL OTHER WARRANTIES, CONDITIONS, AND/ OR REMEDIES UNDER THE LAW, INCLUDING ANY IMPLIED WARRANTIES OR CONDITIONS OF MERCHANTABILITY OR FITNESS FOR A PARTICULAR PURPOSE. THE ORIGINAL OWNER'S SOLE REMEDY WITH RESPECT TO ANY PRODUCTS SHALL BE REPAIR OR REPLACEMENT OF DEFECTIVE PARTS UNDER THE TERMS OF THIS LIMITED WARRANTY. ALL RIGHTS TO CONSEQUENTIAL OR INCIDENTAL DAMAGES, (INCLUDING CLAIMS FOR LOST SALES, LOST PROFITS, PRODUCT LOSS, PROPERTY DAMAGES, OR SERVICE EXPENSES) ARE EXPRESSLY EXCLUDED. THE EXPRESS WARRANTIES MADE IN THIS LIMITED WARRANTY MAY NOT BE ALTERED, ENLARGED, OR CHANGED BY ANY DISTRIBUTOR, DEALER, OR OTHER PERSON, WHATSOEVER.

LEGAL REMEDIES

The owner **must** notify Taylor in writing by certified or registered letter to the following address of any defect or complaint with the Part, stating the defect or complaint and a specific request for repair, replacement, or other correction of the Part under warranty, mailed at least thirty (30) days before pursuing any legal rights or remedies.

Taylor Company
750 N. Blackhawk Blvd.
Rockton, IL 61072, U.S.A.

